

CATALOG

Equipment Leakage

Circuit Interrupters



Carling Technologies®
/// NOW PART OF



Littelfuse®

FOUNDED IN 1920



Since its founding, Carling Technologies has continually forged a tradition of leadership in quality and product innovation.

There are few products that Carling Technologies hasn't turned "ON" and fewer industries that haven't turned to Carling for solutions.

With ISO and TS registered manufacturing facilities and technical sales offices worldwide, Carling ranks among the world's largest manufacturers of circuit breakers, switches, power distribution units, digital switching systems and electronic controls.



SWITCHES & CONTROLS

- Electronic
- Rotary
- Rocker
- Combination
- Toggle
- Battery
- Pushbutton
- Disconnect

CIRCUIT PROTECTION

- Hydraulic-Magnetic
- Thermal
- GFCI / ELCI
- Fuse Links & Holders

CUSTOM SOLUTIONS

- PDU's
- Keypads
- Control Modules

MULTIPLEXED POWER SYSTEMS

- HMI Devices & I/O Modules
- Programmable Displays
- Data Communication Interfaces
- Electrical Systems Monitoring

STRATEGIC MARKETS SERVED:



On/Off Highway



Marine



Telecom/Datacom



Renewable Energy

HEADQUARTERS/MANUFACTURING FACILITIES:



OTHER SERVED INDUSTRIES:



Medical



Industrial Control



Audio / Visual



Commercial Food



HVAC



Floor Care



Generators



Small Appliances



Security Systems



Test & Measurement

COMPETITIVE ADVANTAGES⁺



Innovative & Eco-Friendly Products



Excellent Quality & Customer Service



Reliable & On-Time Delivery



Vertical Integration

WORLDWIDE NUMBERS:



2800+
EMPLOYEES



150+
ENGINEERS



70+
DISTRIBUTORS



50+
REP FIRMS

Table of Content

Selector Guide	4
PB-SERIES	5
PC-SERIES	14

HELPFUL TIP Click on a product to go directly to that page number!

GFCI/ELCI Circuit Protection

This catalog features Carling Technologies' current line of GFCIs/ELCIs products, which offer maximum equipment protection against overload and short circuits.

Carling's Equipment leakage circuit breakers function as hydraulic-magnetic circuit breakers, offering customized overload and short circuit protection. In addition, they sense and guard against faults to ground using innovative electronics technologies. With the exception of small amounts of leakage, the current returning to the power supply will be equal to the current leaving the power supply. If the difference between the current leaving and returning through the earth leakage circuit breaker exceeds the leakage sensitivity setting, the breaker trips and its LED illuminates. The LED gives a clear indication that the trip occurred as a result of leakage to ground. This protection helps prevent serious equipment damage and fire.

Available Online are tools such as a [configurit](#), [product selector](#) and [stock check](#). Please visit www.carlingtech.com for the latest information on all our products.

Application Solution Engineers are readily available to assist you in selecting the appropriate product for your application. For further assistance, please email us at team2@carlingtech.com

Custom Design Solutions can be tailor-made for most any application using our extensive engineering resources.

Other Products such as hydraulic-magnetic and thermal circuit breakers, switches and miniature switches are also available.

© 2020 Carling Technologies, Inc.
Carling Technologies is a registered trademark of Carling Technologies, Inc. in the U.S. and other countries.

Selector Guide



PC-Series

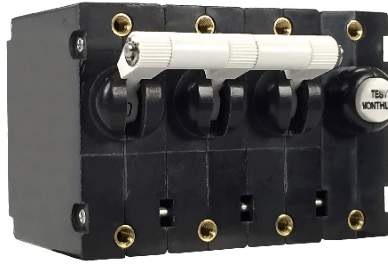

PB-Series

Poles	1-poles (1 circuit breaker + 1 ELCI sensor module), 120V, 2-pole (2 circuit breakers + 1 ELCI sensor module), 120/240V, or 120V with neutral break 2-pole (2 circuit breakers + 1 ELCI sensor module), 240VAC, 3-pole 120/240V with neutral break (sensor module has 2 pole width)	1-3 poles, 3rd pole switched neutral
Actuator Style	handle, rocker, flat rocker, push-to-reset	handle, rocker, flat rocker
Leakage Current Trip Level	30mA	30mA
Leakage Current Trip Time	For 30mA leakage trip: ≤ 22.2mA, shall not trip 30mA, shall trip within .10 seconds, complying with UL-1053 & ABYC E11.	For 30mA leakage trip: ≤ 22.2mA, shall not trip 30mA, shall trip within .10 seconds, complying with UL-1053 & ABYC E11.
Max Current & Voltage Ratings	0.10-50A@120/240VAC - 240VAC	0.10-30A@120/240VAC
Max Interrupting Capacity	5,000A	5,000A
Available Circuits	series trip	series trip
Termination	10-32 threaded stud	.250" tabs, 8-32, 10-32, M4,M5 screw with up-turned lugs, 8-32, 10-32, M4,M5 screw, bus type
Mounting Method	front panel	front panel
Operating Temperature	-35° C to +65° C	-35° C to +65° C
Agency Approvals	UL 1053, UL 1500	UL 1053, UL 1500

PB-Series

Equipment Leakage Circuit Interrupters

PRODUCT WEBPAGE

request sample, configure part

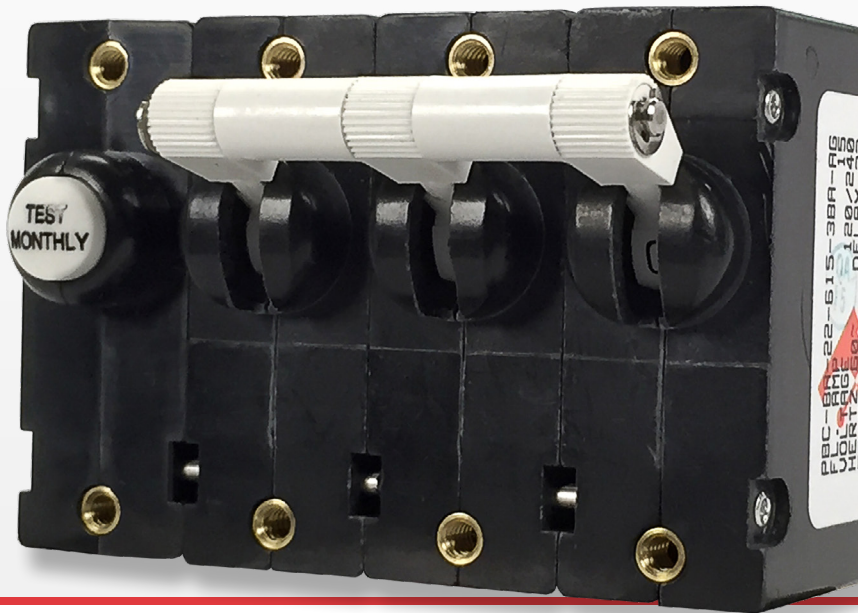

The PB-Series, AC Residual Current Circuit Breaker with Overcurrent Protection (RCBO), combines the ground fault protection and the familiar overcurrent tripping characteristics of a normal circuit breaker, reliably tripping when sensing low level ground or overcurrent faults. Based on the principles of hydraulic-magnetic design, the breaker also operates reliably when exposed to extreme heat or cold. This breaker series is available in one to three pole configurations and rated from .10-30 amps, 120VAC, 120/240VAC with max IC of 5,000 amps.

1-3 Poles **0.10-30** Amps **120/240** VAC **5,000A Max** Interrupting Capacity

Typical Applications

- Marine
- Generators
- Lighting

Tech Specs

Electrical

Maximum Voltage	120/240VAC 60 Hz
Current Ratings	Standard current coils: 0.100, 0.250, 0.500, 0.750, 1.00, 2.50, 5.00, 7.50, 10.0, 15.0, 20.0, 25.0 & 30.0 amps. Other ratings available, see ordering scheme.
Insulation Resistance	Minimum of 100 Megohms at 500 VDC
Dielectric Strength	UL, CUL - 1500 V 60 Hz for one minute between all electrically isolated terminals. PB-Series circuit breakers comply with the 8mm spacing and 3750V 60 Hz dielectric requirements from hazardous voltage to operator accessible surfaces and between adjacent poles
Impedance	Values from Line to Load Terminal

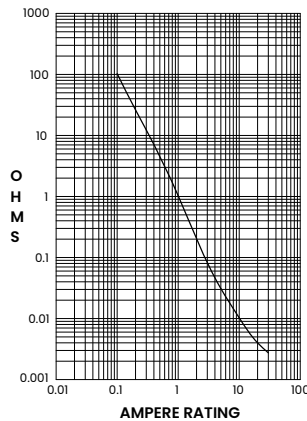

Ampere Rating

CURRENT (AMPS)	TOLERANCE (%)
0.10 - 5.0	± 15
5.10 - 20.0	± 25
20.10 - 30.0	± 35

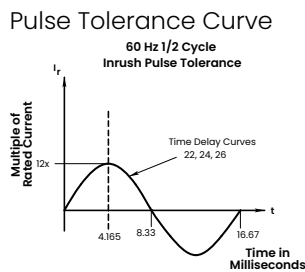

Leakage To Ground

Standard Must Trip	120/240VAC 60 Hz
Leakage Current Ratings	30 milliamps
Trip Time	Minimum of 100 Megohms at 500 VDC.
Test Button	300 ms Max. @ 100%, 40ms Max. @ 500% of must trip leakage current.
Impedance	On unit face along side of actuator.

Tables

Table A: UL Listed configurations and performance capabilities as Circuit Breakers.

Electrical Ratings					
Circuit Configuration	Voltage			Current Rating (Amps)	Interrupting Capacity (Amps)
	Max Rating	Frequency	Phase		
Series	120	60	1	.10 - 30	5000
Series Ignition Protection					3000

*Manufacturer reserves the right to change product specification without prior notice.

Mechanical

Endurance	6,000 ON-OFF operations @ 6 per minute; 4,000 mechanical with rated Current & Voltage.
Trip Free	All PB-Series Circuit Breakers will trip on overload or ground fault, even when Handle is forcibly held in the ON position.
Trip Indication	The operating Handle moves positively to the OFF position when an overload or ground fault causes the breaker to trip.

Physical

Number of Poles	1 - 3 poles, where the third pole is neutral
Internal Circuit Config.	Series Trip
Weight	Approximately 65 grams/pole. (2.32 ounces/pole.)
Standard Colors	Housing- Black; Actuator - See Ordering Scheme.

Environmental

Designed and tested in accordance with requirements of specification MIL-PRF- 55629 and MIL-STD-202 as follows:

Shock	Withstands 100 Gs, 6ms, sawtooth while carrying rated current per Method 213, Test Condition "I". Ultra-short curves tested @ 90% of rated current.
Vibration	Withstands 0.060" excursion from 10-55 Hz, and 10 Gs 55-500 Hz, at rated current per Method 204C, Test Condition A. Instantaneous and ultrashort curves tested at 90% of rated current.
Moisture Resistance	Method 106D, i.e., ten 24-hour cycles @ + 25°C to +65°C, 80-98% RH.
Salt Spray	Method 101, Condition A (90-95% RH @ 5% NaCl Solution, 96 hrs).
Thermal Shock	Method 107D, Condition A (Five cycles @ -55°C to +25°C to +85°C to +25°C).
Operating Temperature	-35° C to +65° C
Corrosion	Tested FMG Test. 3 weeks @ 30°C 75% RH, 100ppb H2S, 20ppb Cl2, 200ppb NO2

Agency Approvals

UL 1053	Ground Fault Sensing and Relaying Equipment
UL 1500	Ignition Protection

Ordering Scheme

Sample Part Number **PB B - B A - 24-620 - 2 B A - E G**

Selection 1 2 3 4 5 6 7 8 9 10 11

1. SERIES

PB

2. SYSTEM VOLTAGE / POLES

- A 120 VAC single phase, one pole
- B 120/240 VAC single phase, two pole
- C 120/240 VAC single phase with switched neutral, three pole
- D 120 VAC two pole with switched neutral

3. POLES

B Series Trip (Current)

4. CIRCUIT

- | | |
|-------------------------------------|-----------------------------------|
| Handle | Single Color Curved Rocker |
| A one per pole | J Vertical legend |
| B one per multipole unit | K Horizontal legend |
| Two Color Curved Visi-Rocker | Two Color Flat Visi-Rocker |
| C Indicate ON, vertical legend | 1 Indicate OFF, vertical legend |
| D Indicate ON, horizontal legend | 2 Indicate OFF, horizontal legend |
| F Indicate OFF, vertical legend | Single Color Flat Rocker |
| G Indicate OFF, horizontal legend | 3 Vertical legend |
| | 4 Horizontal legend |

ROCKER STYLE DESCRIPTIONS					
	INDICATE "ON"	INDICATE "OFF"	SINGLE COLOR	INDICATE "OFF"	SINGLE COLOR
VERTICAL	CODE "C" 	CODE "F", "N" 	CODE "J", "R" 	CODE "1", "5" 	CODE "3", "7"
	CODE "D" 	CODE "G", "O" 	CODE "K", "U" 	CODE "2", "6" 	CODE "4", "8"
HORIZONTAL					

5. FREQUENCY & DELAY

- 21 50 / 60Hz Ultra Short
- 22 50 / 60Hz Short
- 24 50 / 60Hz Medium
- 26 50 / 60Hz Long

6. CURRENT RATING (AMPERES)

CODE	AMPERES	CODE	AMPERES	CODE	AMPERES	CODE	AMPERES
210	0.10	285	0.85	450	5.00	712	12.50
215	0.15	290	0.90	455	5.50	613	13.00
220	0.20	295	0.95	460	6.00	614	14.00
225	0.25	410	1.00	465	6.50	615	15.00
230	0.30	512	1.25	470	7.00	616	16.00
235	0.35	415	1.50	475	7.50	617	17.00
240	0.40	517	1.75	480	8.00	618	18.00
245	0.45	420	2.00	485	8.50	620	20.00
250	0.50	522	2.25	490	9.00	622	22.00
255	0.55	425	2.50	495	9.50	624	24.00
260	0.60	527	2.75	610	10.00	625	25.00
265	0.65	430	3.00	710	10.50	630	30.00
270	0.70	435	3.50	611	11.00		
275	0.75	440	4.00	711	11.50		
280	0.80	445	4.50	612	12.00		

7. TERMINAL 2

- 1³ Push-On 0.250 Tab (Q.C.)
- 2 Screw 8-32 w/upturned lugs
- 3 Screw 8-32 (Bus Type)
- 4 Screw 10-32 w/upturned lugs
- 5 Screw 10-32 (Bus Type)
- B Screw M5 w/upturned lugs
- C Screw M4 w/upturned lugs
- E Screw M4 (Bus Type)
- H Screw M5 (Bus Type)

8. ACTUATOR COLOR & LEGEND

Handle Color	I-O	ON-OFF	Dual	Single	Visi-Rocker
White	A	B	1	Black	White
Black	C	D	2	White	N/A
Red	F	G	3	White	Red
Green	H	J	4	White	Green
Blue	K	L	5	White	Blue
Yellow	M	N	6	Black	Yellow
Gray	P	Q	7	Black	Gray
Orange	R	S	8	Black	Orange

9. MOUNTING / BARRIERS

	MOUNTING STYLE	BARRIERS
A	Threaded Insert, 2 per pole	
B	6-32 X 0.195 inches	yes
	M3 x 5mm	yes
C	Rockerguard Bezel, 2 per pole	
D	6-32 x 0.195"	yes
	M3 x 5 mm	yes
E	Standard Bezel with Recessed Off-Side Flat Rocker	
	Threaded Insert, 2 per pole	
F	6-32 x 0.195"	yes
	M3 x 5 mm	yes

10. LEAKAGE CURRENT TRIP LEVEL - MAX. TRIP CURRENT

E 30 MA (ELCI) ¹

11. AGENCY APPROVAL

- A without Approvals
- G 30 mA: UL 1053 Recognized Component, CSA Recognized Component with UL Listed Circuit Breakers
- I 30 mA: UL 1053 Recognized Component, CSA Recognized Component with UL 1077 Supplementary Protectors with UL 1500 Ignition Protection

Notes:

- 1 Actuator Code:
 - A: Handle tie pin spacer(s) and retainers provided unassembled with multi-pole units.
 - B: Handle location as viewed from front of breaker:
 - 2 pole - left pole 3 pole - center pole
- 2 Screw Terminals are recommended on ratings greater than 20 amps.

[Configure Complete Part Number >](#)

[Browse Standard Parts >](#)

Dimensional Specs

inches [millimeters]

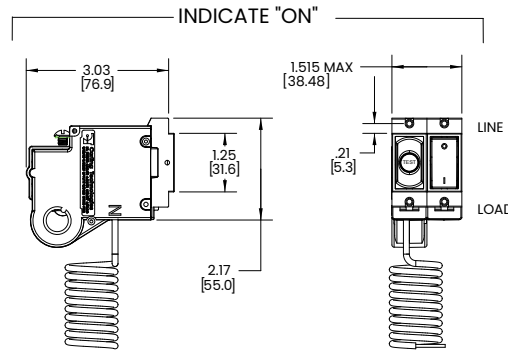

1-POLE 120 VAC VERSION

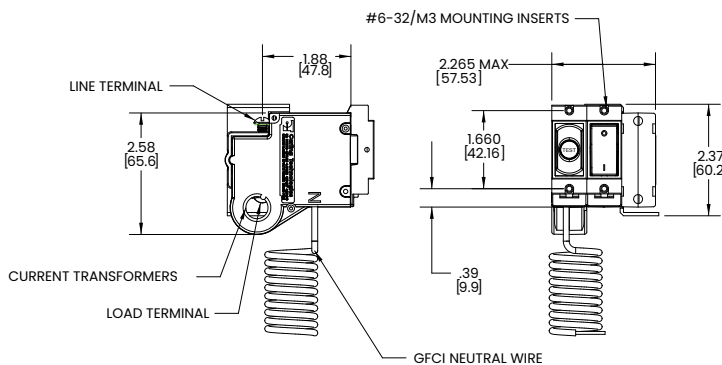
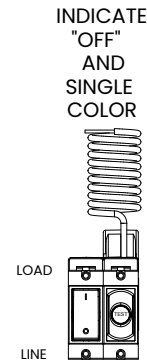

2-POLE 120/240 VAC VERSION

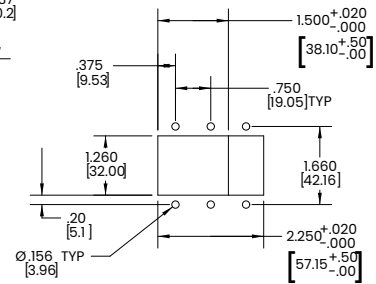

PANEL CUTOUT

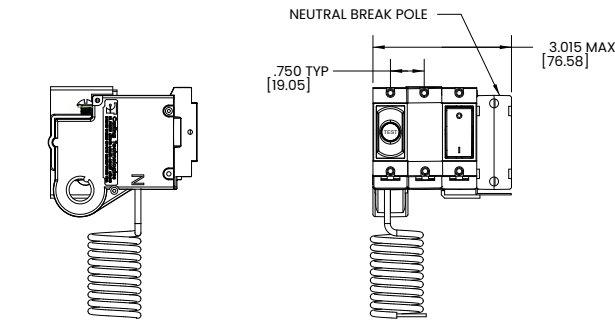

2-POLE 120/240 VAC WITH NEUTRAL BREAK

TERMINAL DIMENSIONAL DETAIL & RATING

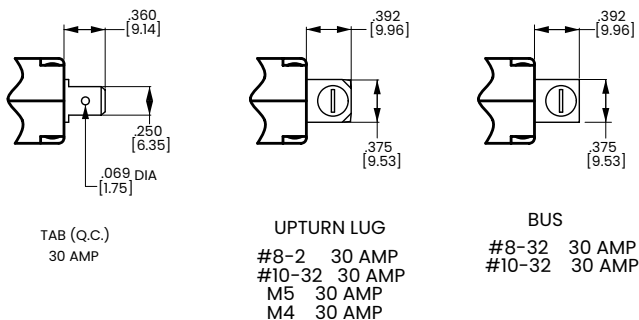

TABLE A
TIGHTENING TORQUE
SPECIFICATIONS

THREAD SIZE	TORQUE
#6-32 & M3 MOUNTING HARDWARE	7-9 IN-LBS [0.8-1.0 NM]
#8-32 & M4 THREAD TERMINAL SCREW	12-15 IN-LBS [1.4-1.7 NM]
#10-32 & M5 THREAD TERMINAL SCREW	15-20 IN-LBS [1.7-2.3 NM]

Notes:
1 Tolerance ± 0.020 [.51] unless otherwise specified.

Dimensional Specs

inches [millimeters]

TYPICAL 2-POLE 120 VAC VERSION

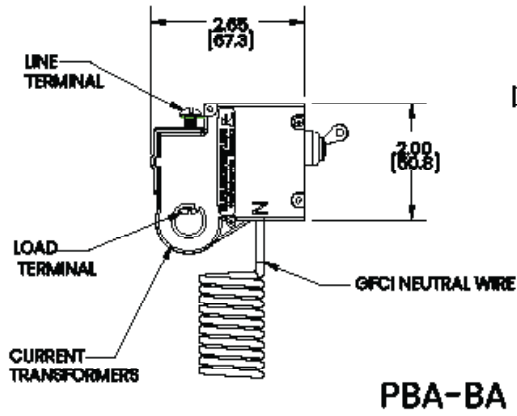

TYPICAL 2-POLE 120/240 VAC WITH NEUTRAL BREAK VERSION

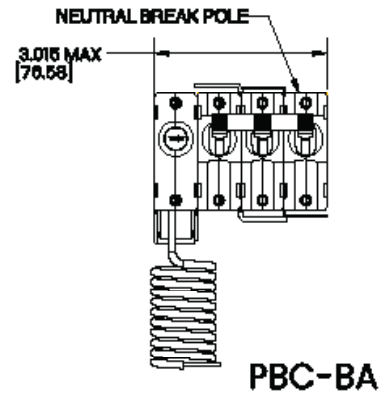

TYPICAL 2-POLE 120/240 VAC VERSION

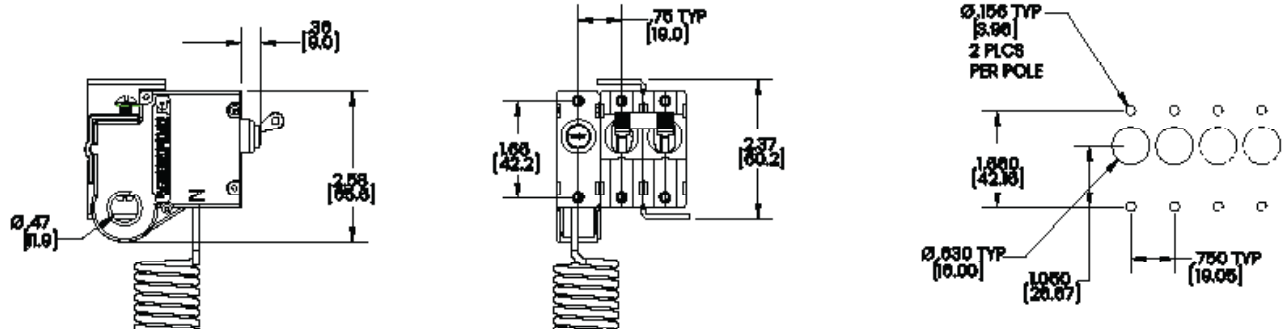

Notes:

1 Tolerance ± 0.020 [.51] unless otherwise specified.

Wiring Diagrams

120 VAC with Switched Neutral

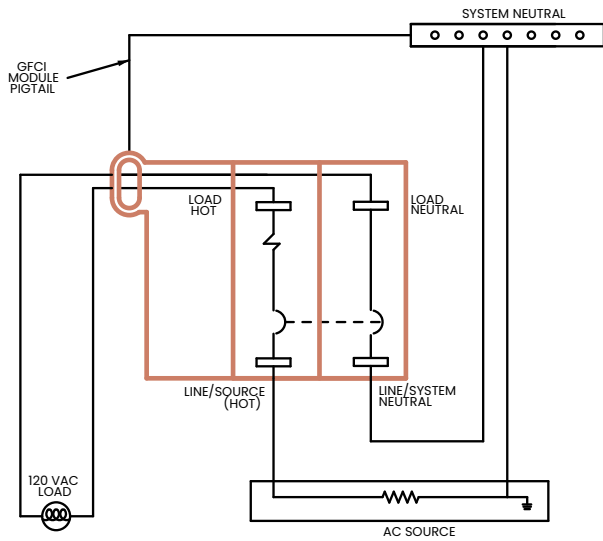

120 VAC WITH SWITCHED NEUTRAL

120 VAC without Switched Neutral

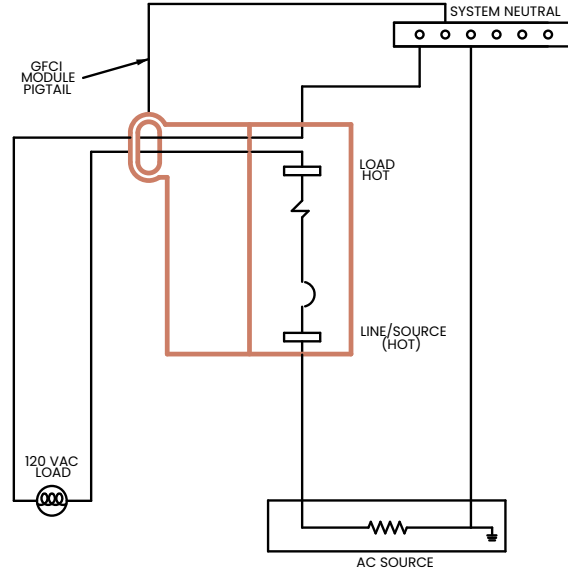

120 VAC WITHOUT SWITCHED NEUTRAL

120/240 VAC with Switched Neutral

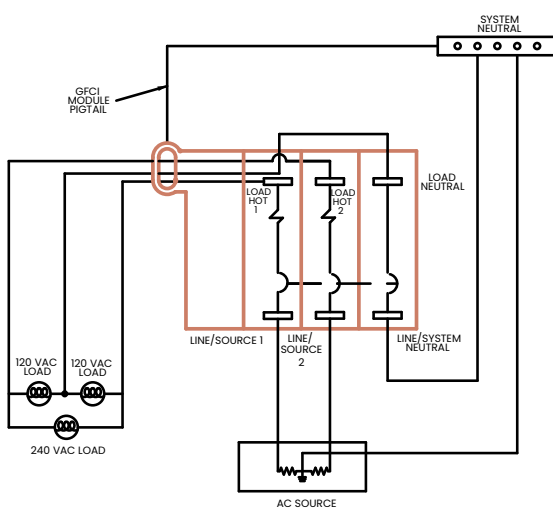

120 VAC WITH SWITCHED NEUTRAL

120/240 VAC without Switched Neutral

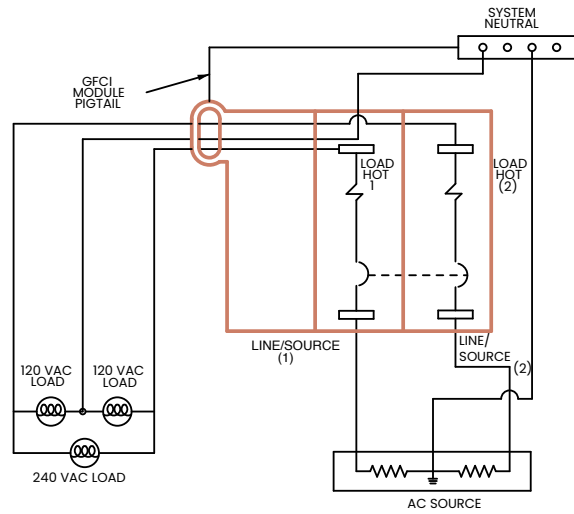

120 VAC WITHOUT SWITCHED NEUTRAL

Ordering Scheme

Sample Part Number 8 PB - 1 4 1

Selection 1 2 3 4 5

1. TYPE NUMBER

8

2. SERIES

PB

3. ACTUATOR TYPE

- 1 Handle, one per pole
- 2 Handle, one per multipole unit
- A Rocker ²

4. POLES PER UNIT - INCLUDING ELECTRONIC MODULE

- 2 Two
- 3 Three
- 4 Four

5. MOUNTING SCREWS / PLATE MATERIAL 1

- 1 6-32 Thread Phillips Head
- 2 M-3 Thread Phillips Head
- 3 6-32 Thread Slotted Head
- 4 M-3 Thread Slotted Head
- 5 6-32 Thread Phillips Head with Stainless Steel Plate
- 6 M-3 Thread Phillips Head with Stainless Steel Plate
- 7 6-32 Thread Slotted Head with Stainless Steel Plate
- 8 M-3 Thread Slotted Head with Stainless Steel Plate

Notes:

- 1 Screws supplied to accommodate mounting panel thickness of $1/8" \pm 1/32"$. Consult Factory for additional options
- 2 Available for Flat and Curved Rocker options - No Rockerguard Bracket

Handle Style Panel Seal

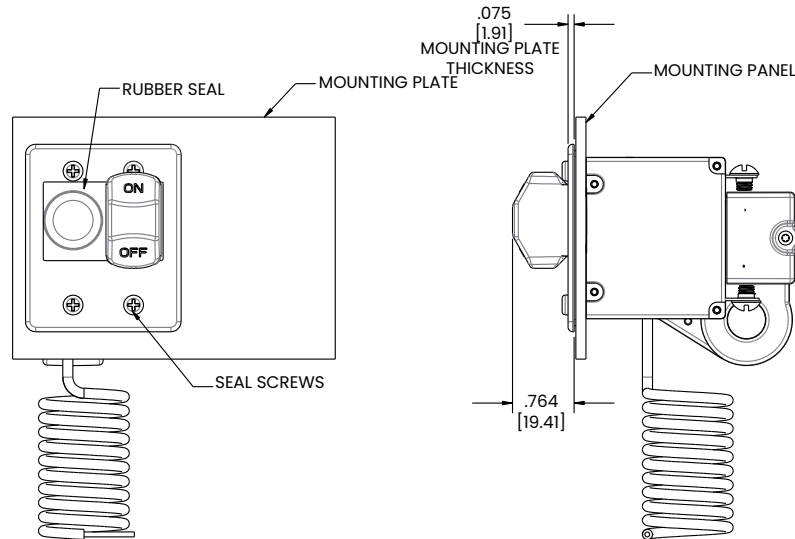

Rocker Style Panel Seal

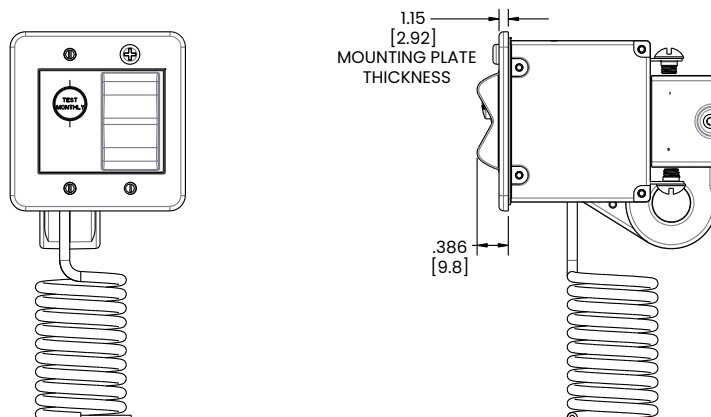

Dimensional Specs

Handle Actuator

HANDLE, 1 PER POLE

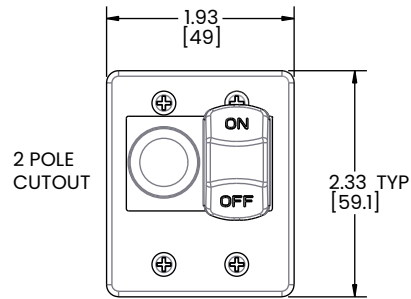

8PB-12

HANDLE, 1 PER MULTIPOLE UNIT

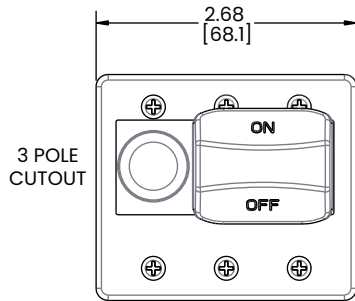

8PB-13

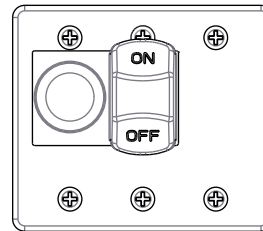

8PB-23

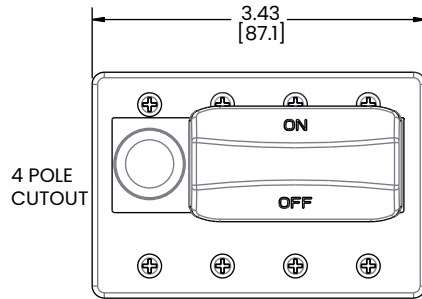

8PB-14

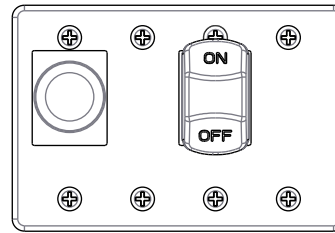

8PB-24

Rocker Actuator

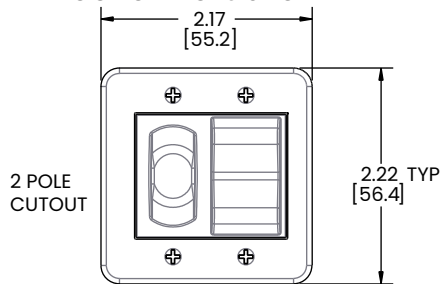

8PB-A2

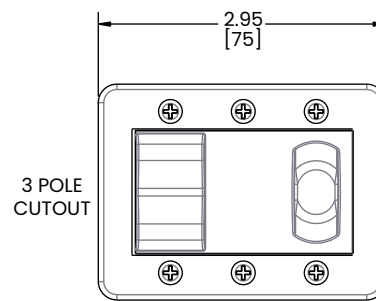

8PB-A3

Time Delay

Ultra Short

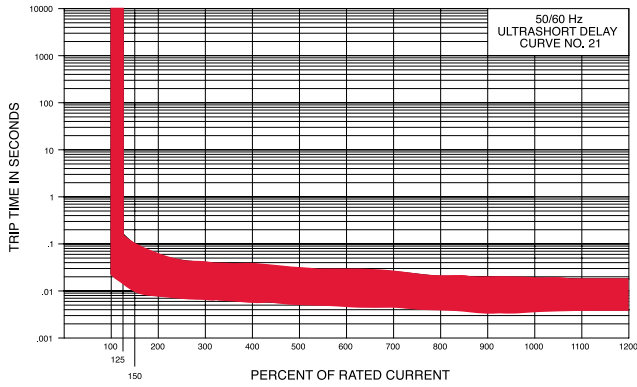

Medium

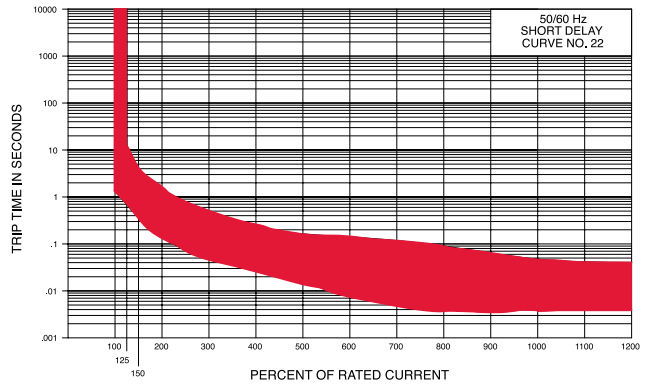

Short

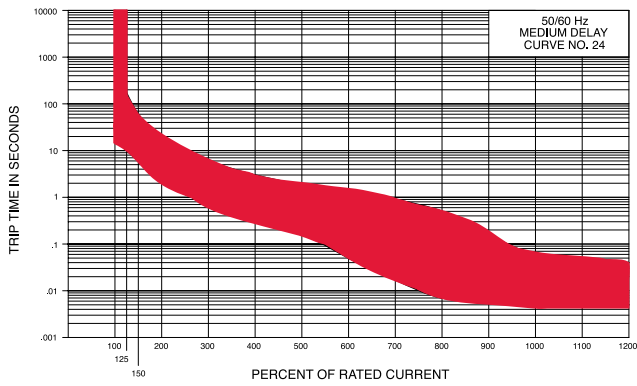

Long

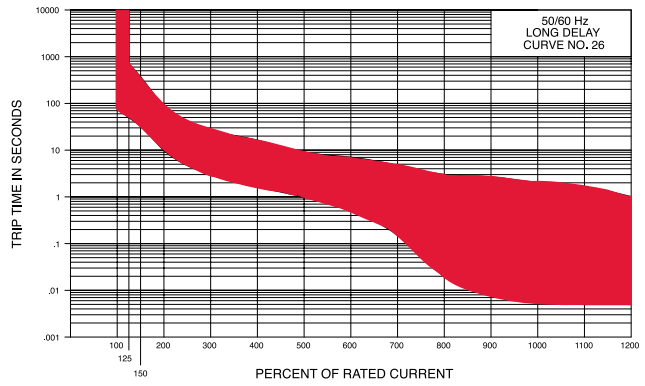

PC-Series

Equipment Leakage Circuit Interrupters

PRODUCT WEBPAGE

request sample, configure part

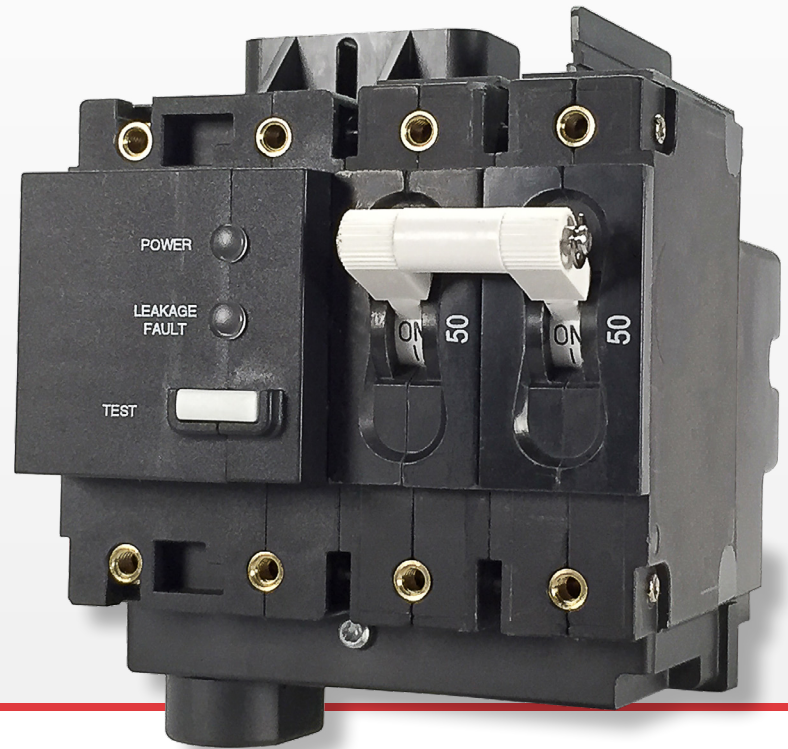

The PC-Series, AC Residual Current Circuit Breaker with Overcurrent Protection (RCBO), combines ground fault protection with the familiar overcurrent tripping characteristics of a normal circuit breaker to protect against low-level faults when installed near water. Based on the principles of hydraulic-magnetic design, the breaker also operates reliably when exposed to extreme heat or cold. This breaker series is available in one to three pole configurations and rated from .10-50 amps, 120VAC, 120/240VAC with max IC of 5,000 amps

1-3 **0.10-50** **120/240** **5,000A Max**
Poles Amps VAC Interrupting Capacity

Typical Applications

- Marine
- Battery Chargers
- AC Water Heaters
- AC Main Ground Fault Protection for a boat's entire AC electrical system

Tech Specs

Electrical

Current Ratings	50 Amps maximum
Voltage Ratings	120 VAC, 120/240 VAC
Dielectric Strength	1480 VAC, 60Hz for 1 minute between all electrically isolated terminals
Insulation Resistance	Minimum of 100 Megohms at 500VDC
Leakage Current Trip Time	≤ 25 ms
EMI	UL 943 / IEC 61000-4-6, 0.5V 150KHz ~ 230 MHz
Operating Frequency	50/60 Hz
Reverse Polarity	A reversed Line / Load connection to the circuit breaker shall not cause damage to the device
Grounded Neutral	When neutral is grounded on load side of circuit
Overload	50 operations @ 600% of rated current on Breakers
Switched Neutral	2nd Pole on 120V and 3rd Pole on 120/240V, Optional
Manual Test	To be performed at least every month by pressing the test button on the ELCI to verify the device's ability to respond and trip when subjected to simulated leakage. Current imbalance is sufficient to cause tripping at 85% of rated voltage. Line Power at LI is required.

Impedance (Across Circuit breaker only)

RESISTANCE, IMPEDANCE VALUES
from Line to Load Terminals
(Values Based on Series Trip Circuit Breaker)

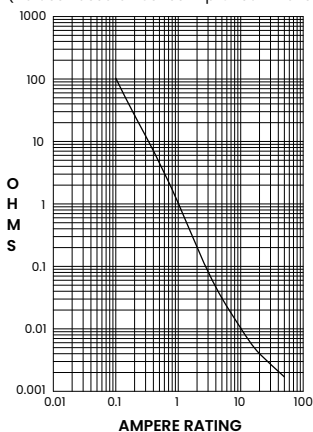

CURRENT (AMPS)	TOLERANCE (%)
0.10 - 5.0	± 15
5.10 - 20.0	± 25
20.10 - 50.0	± 35

Physical

Number of Poles	1-pole (1 Circuit Breaker + 1 ELCI Sensor Module), 120V. 2-pole (2 Circuit Breakers + 1 ELCI Sensor Module), 120/240V or 120V with Switched Neutral. 3-pole (3 Circuit Breakers + 1 ELCI Sensor Module), 120/240V with Switched Neutral.
Termination	Circuit Breaker Line Side: #10-32 ELCI Sensor Module Load Side: #10-32. Neutral pigtail provided with non-switched neutral units.
Mounting	Front Panel, #6-32 or M3 threaded inserts.
Actuator	Handle, Flat Rocker, Curved Rocker (with or without rocker guard), Push-to-Reset Rocker
Internal Circuit Config.	Circuit Breaker, Series Trip Switch only (without over-current protection)
Weight	1-pole: approx. 300 grams (10.6 ounces). 2-pole: approx. 375 grams (13.2 ounces) 3-pole: approx. 500 grams (17.6 ounces)
Standard Colors	Housing – Black, Test Button – White, Text – White

Environmental

Designed and tested in accordance with requirements of specification MIL-PRF- 55629 and MIL-STD-202G as follows:

Shock	Withstands 100 G, 6ms, sawtooth at rated current per Method 213, Test Condition "I".
Thermal Shock	Method 107D, Condition A (5-cycle at -55°C to +25°C to +85°C to +25°C)
Vibration	Withstands 0.06" excursion from 10-55 Hz, and 10 G 55-500 Hz, at rated current per Method 204C, Test Condition A. Instantaneous & ultrashort curves tested at 90% of rated current.
Moisture Resistance	93% RH at 30°C for 168 Hours.
Operating Temperature	-35°C to +66°C
Corrosion	3 weeks Humidity: 30±2°C, 70±2% relative humidity Mixed Flowing Gases: 100 ppb H ₂ S, 20 ppb Cl ₂ , 200±50 ppb NO ₂

Mechanical

Endurance	10,000 "On-Off" Operations at 6 per minute; 6000 with Rated Current & Voltage (3000 test button and 3000 manual operations) and 4000 on/off operations with no load.
Trip Free	Trips on short circuit, overload or leakage to ground, even when actuator is forcibly held in the "On" position

Tech Specs

Agency Approvals

UL 1053	Ground Fault Sensing and Relaying Equipment
UL 1500	Ignition Protection

Tables

Table A: UL Recognized as an Equipment Leakage Circuit Interruptor - 120 and 120/240V

UL Recognized Configurations as an Equipment Leakage Circuit Interruptor							
Circuit Configuration	Voltage			Current Rating (Amps)	Short Circuit Capacity (Amps)	Ground Fault Trip Level (Milliamps)	Construction Notes
	Max Rating	Frequency (Hertz)	Phase				
Series	120	50 / 60	1	1 - 50	5000	30	1 or 2 Poles. One pole of a two pole unit must be Neutral
	120 / 240						2 or 3 Poles. One pole of a three pole unit must be Neutral
Series Ignition Protection	120	50 / 60	1	1 - 50	3000	30	1 or 2 Poles. One pole of a two pole unit must be Neutral
	120 / 240						2 or 3 Poles. One pole of a three pole unit must be Neutral

Table B: UL Recognized as an Equipment Leakage Circuit Interruptor - 240V

UL Recognized Configurations as an Equipment Leakage Circuit Interruptor - 240V							
Circuit Configuration	Voltage			Current Rating (Amps)	Short Circuit Capacity (Amps)	Ground Fault Trip Level (Milliamps)	Construction Notes
	Max Rating	Frequency (Hertz)	Phase				
Series	240	50 / 60	1	1 - 30	5000	30	2 or 3 Poles. One pole of a three pole unit must be Neutral. Suffix 11
Series Ignition Protection				1 - 50			3000

ELCI Test Instructions

1. Turn "OFF" the Breaker actuator. Turn on the power to the panel. The green and red LED's should be off.
2. Turn "ON" the Breaker actuator. The green "POWER" LED should show steady illumination and the red "LEAKAGE FAULT" LED should flash every 3 seconds to indicate a successful self-test.
3. Depress the "TEST" button. This will cause the actuator to move to the "OFF" position and the red LED to turn on and show steady illumination, indicating that the ELCI is functioning properly. The green LED will also go from steady to off. If the actuator fails to move to the "OFF" position or the red LED fails to illuminate, the unit MUST be replaced.
4. Turn the Breaker actuator to the "ON" position. The green LED should flash every 3 seconds and the Red LED should show be off.
5. This test is to be performed on a monthly basis and recorded on the "Monthly Test Reminder" label.

ELCI LED Indication

Indicator - Two integrated LEDs, Red & Green

1. Green LED On, Red LED Off - Line Voltage is present, the breaker is closed, and the device is protecting the circuits against over current and leakage current.
2. Green LED Off, Red LED On - The device has detected leakage current and has opened the circuit breaker.
3. Green LED Flashing, Red LED Off - The circuit breaker has opened due to over current or has been turned off manually
4. Green LED Off, Red LED Off - Line Voltage is not present
5. Green LED Flashing, Red LED Off, Amber LED ON - Indicates Hot & Neutral are reversed and the circuit breaker is open

Neutral Protection - When neutral is grounded on load side of circuit

Test Button - Located on Ground Fault Module

Ordering Scheme

Sample Part Number

PC B - B A - 24-620 - 1 B A - E 11

Selection

1 2 3 4 5 6 7 8 9 10 11

1. SERIES

PC

2. SYSTEM VOLTAGE / POLES

A 120 VAC single phase, 1 pole
B 120/240 VAC single phase, 2 pole
C 120/240 VAC single phase with switched neutral, 3 pole
D 120 VAC single phase with switched neutral, 2 pole
G 240 VAC single phase, 2 pole

3. POLES

B Series Trip (Current)

4. CIRCUIT

Handle
A 1 per breaker pole
B 1 per unit
Two Color Curved Visi-Rocker
C Indicate ON, vertical legend
D Indicate ON, horizontal legend
F Indicate OFF, vertical legend
G Indicate OFF, horizontal legend
Single Color Curved Rocker
J Vertical legend
K Horizontal legend
Two Color Curved Visi-Rocker Push-to-Reset
N Indicate OFF, Vertical legend
O Indicate OFF, Horizontal legend

Single Color Curved Rocker Push-to-Reset
R Vertical legend
U Horizontal legend

Two Color Flat Visi-Rocker
1 Indicate OFF, vertical legend
2 Indicate OFF, horizontal legend
Single Color Flat Rocker
3 Vertical legend
4 Horizontal legend
Two Color Flat Visi-Rocker Push-to-Reset
5 Indicate OFF, vertical legend
6 Indicate OFF, horizontal legend
Single Color Flat Rocker Push-to-Reset
7 Vertical legend
8 Horizontal legend

ROCKER STYLE DESCRIPTIONS					
	INDICATE "ON"	INDICATE "OFF"	SINGLE COLOR	INDICATE "OFF"	SINGLE COLOR
VERTICAL STYLE	CODE "C" 	CODE "F", "N" 	CODE "J", "R" 	CODE "1", "5" 	CODE "3", "7"
	INDICATE LOCATION 			INDICATE LOCATION 	
HORIZONTAL STYLE	CODE "D" 	CODE "G", "O" 	CODE "K", "U" 	CODE "2", "6" 	CODE "4", "8"

5. FREQUENCY & DELAY

20 50 / 60Hz Instantaneous
21 50 / 60Hz Ultra Short
22 50 / 60Hz Short
24 50 / 60Hz Medium
26 50 / 60Hz Long

6. CURRENT RATING (AMPERES)

CODE	AMPERES	CODE	AMPERES	CODE	AMPERES	CODE	AMPERES
410	1.00	445	4.50	610	10.00	618	18.00
512	1.25	450	5.00	710	10.50	620	20.00
415	1.50	455	5.50	611	11.00	622	22.00
517	1.75	460	6.00	711	11.50	624	24.00
420	2.00	465	6.50	612	12.00	625	25.00
522	2.25	470	7.00	712	12.50	630	30.00
425	2.50	475	7.50	613	13.00	635	35.00
527	2.75	480	8.00	614	14.00	640	40.00
430	3.00	485	8.50	615	15.00	650	50.00
435	3.50	490	9.00	616	16.00		
440	4.00	495	9.50	617	17.00		

7. TERMINAL

1 Stud, 10-32 threaded

8. ACTUATOR COLOR & LEGEND

Handle Actuator Color	I-O	ON-OFF	Dual	Rocker Actuator Color	Single	Visi-Rocker
White	A	B	1	Black	Black	White
Black	C	D	2	White	White	N/A
Red	F	G	3	White	White	Red
Green	H	J	4	White	White	Green
Blue	K	L	5	White	White	Blue
Yellow	M	N	6	Black	Black	Yellow
Gray	P	Q	7	Black	Black	Gray
Orange	R	S	8	Black	Black	Orange

9. MOUNTING / BARRIERS

MOUNTING STYLE	BARRIERS
Threaded Insert, 2 per pole	
A 6-32 X 0.195 inches	yes
B ISO M3 x 5mm	yes
Rockerguard Bezel	
Threaded Insert, 2 per pole	
C 6-32 X 0.195 inches	yes
D ISO M3 x 5mm	yes
Standard Bezel with Recessed Off-Side Flat Rocker	
Threaded Insert, 2 per pole	
E 6-32 X 0.195 inches	yes
F ISO M3 x 5mm	yes
Push-to-Reset Bezel	
Threaded Insert, 2 per pole	
G 6-32 X 0.195 inches	yes
H ISO M3 x 5mm	yes

10. LEAKAGE CURRENT TRIP LEVEL - MAX. TRIP CURRENT

E 30 MA (ELCI) ¹

11. AGENCY APPROVAL

AA without Approvals
11 30 mA: UL 1053 Recognized Component, CSA Recognized Component with UL Listed Circuit Breakers ¹
12 30 mA: UL 1053 Recognized Component, CSA Recognized Component with UL 1077 Supplementary Protectors with UL 1500 Ignition Protection ¹

Notes:

¹ This device meets the requirements of ABCY EII.

[Configure Complete Part Number >](#)

[Browse Standard Parts >](#)

Dimensional Specs

inches [millimeters]

INDICATE OFF / SINGLE COLOR
ROCKER ACTUATOR

HANDLE / INDICATE ON
ROCKER ACTUATOR

TERMINAL
LOCATIONS

PCA
120 VAC
VERSION

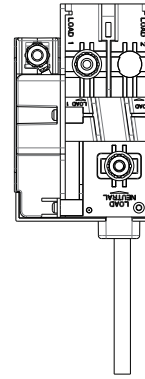
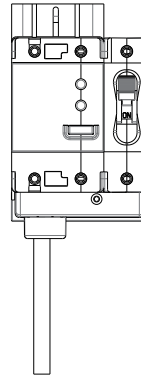
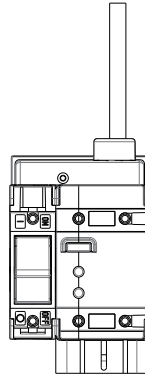

PCB
120/240 VAC
VERSION

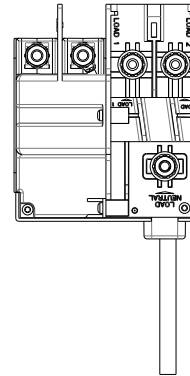
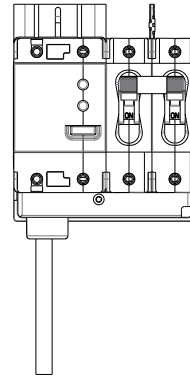
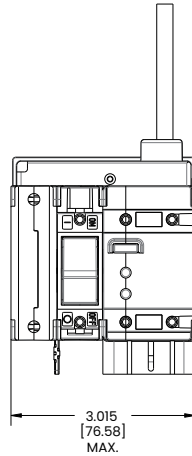

PCC
120/240 VAC
VERSION
W/ NEUTRAL BREAK

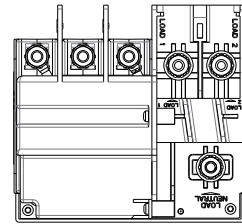
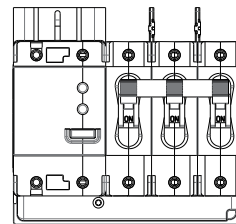
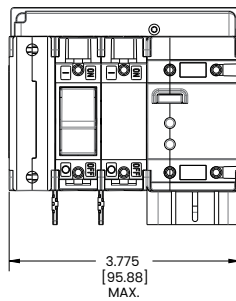

PCD
120 VAC
VERSION
W/NEUTRAL BREAK

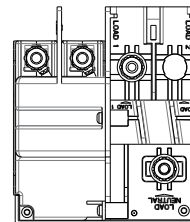
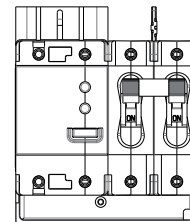
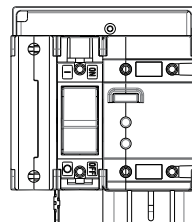

Dimensional Specs

inches [millimeters]

NOTE: NEUTRAL - SUPPLIED 12" LONG MIN. (CIRCUIT CODES A,B,E & F)

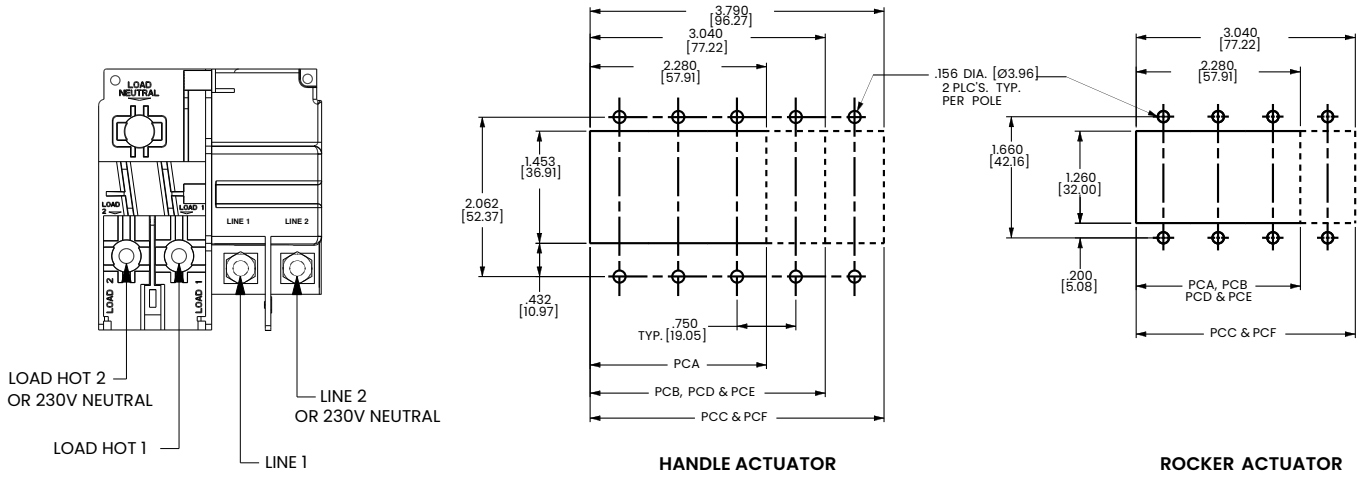

PANEL CUTOUT DETAIL

TOLERANCES ±.005[.12]

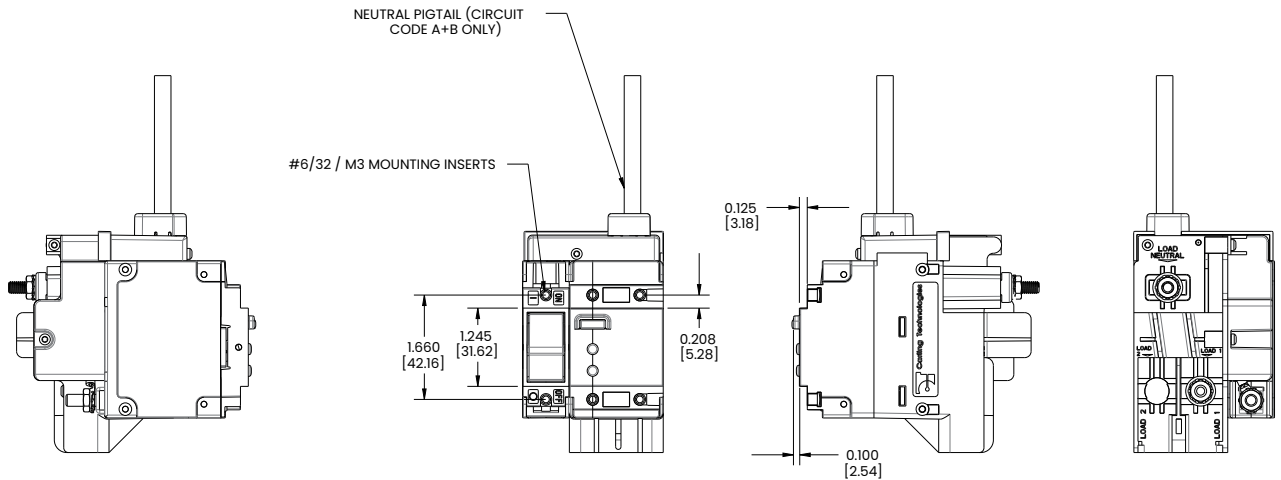
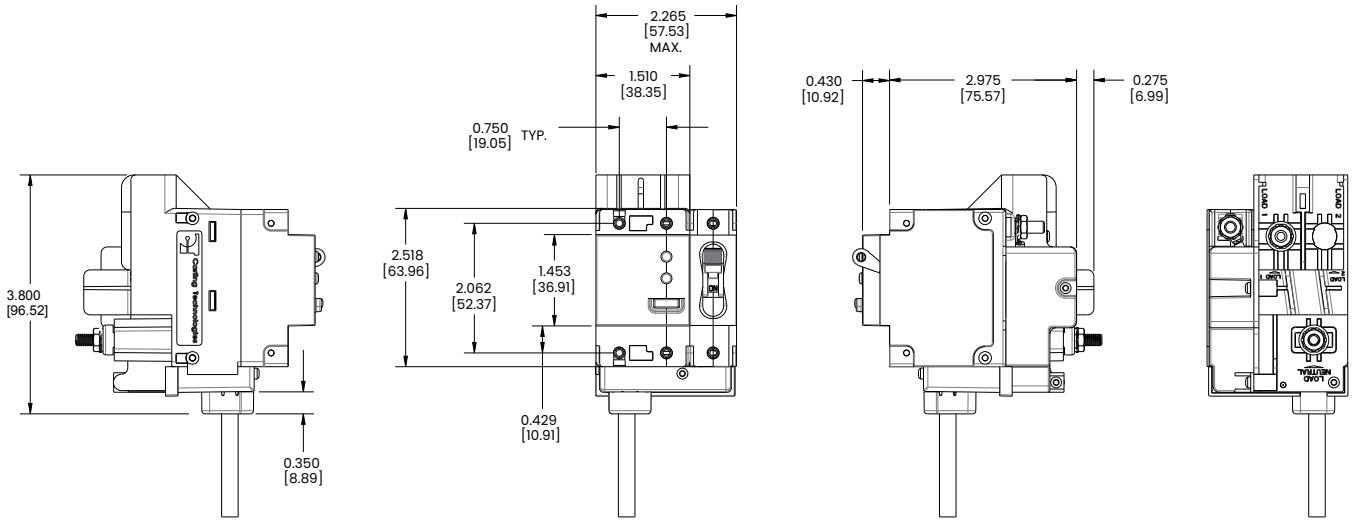

Notes:
For additional circuit breaker dimensions, reference the C-Series Breakers in the Carling Circuit Protection catalog

Ordering Scheme

Sample Part Number 8 PC - 1 3 1

Selection 1 2 3 4 5

1. TYPE NUMBER

8 Circuit Breaker Assembly

2. SERIES

PC

3. ACTUATOR TYPE

- 1 Handle, one per pole
- 2 Handle, one per multipole unit
- A Rocker

4. POLES PER UNIT - INCLUDING ELECTRONIC MODULE

- 3 Three
- 5 Five

5. MOUNTING SCREWS / PLATE MATERIAL ¹

- 1 6-32 Thread Phillips Head
- 2 M-3 Thread Phillips Head
- 3 6-32 Thread Slotted Head
- 4 M-3 Thread Slotted Head
- 5 6-32 Thread Phillips Head with Stainless Steel Plate
- 6 M-3 Thread Phillips Head with Stainless Steel Plate
- 7 6-32 Thread Slotted Head with Stainless Steel Plate
- 8 M-3 Thread Slotted Head with Stainless Steel Plate

Notes:

- 1 Screws supplied to accommodate mounting panel thickness of $1/8" \pm 1/32"$. Consult Factory for additional options
- 2 Available for Flat and Curved Rocker options - No Rockerguard Bracket

Handle Style Panel Seal

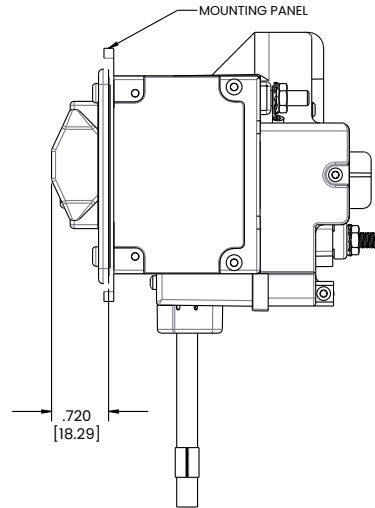
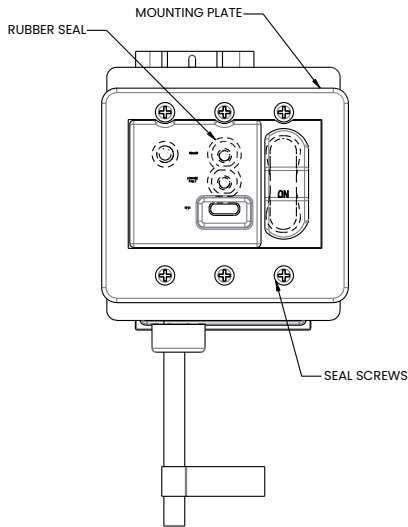

Rocker Style Panel Seal

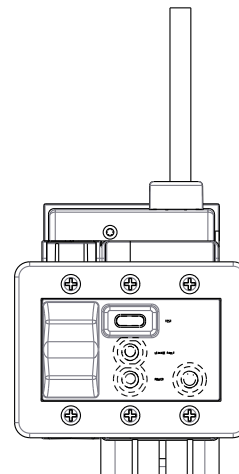
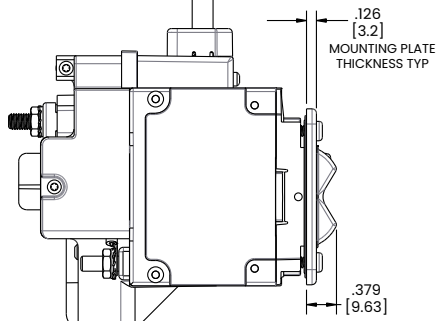

Dimensional Specs

Handle Actuator

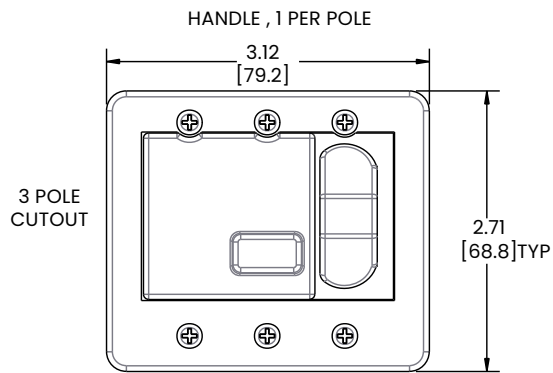

8PC-13

HANDLE, 1 PER MULTIPOLE UNIT

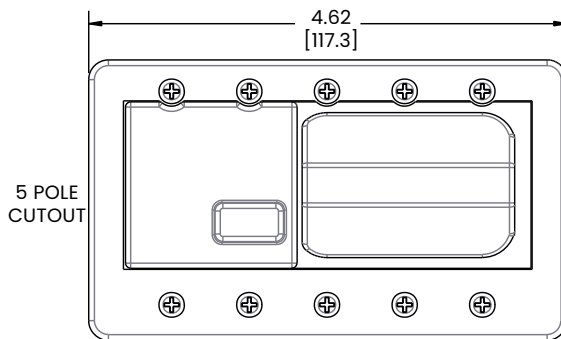

8PC-15

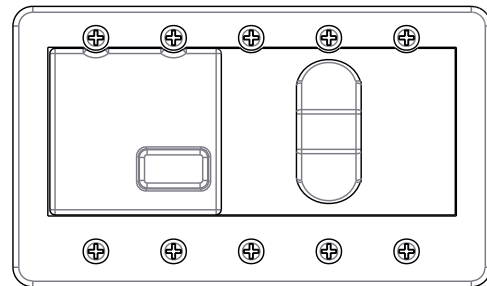

8PC-25

Rocker Actuator

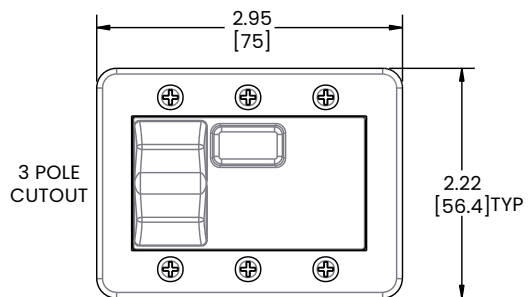

8PC-A3

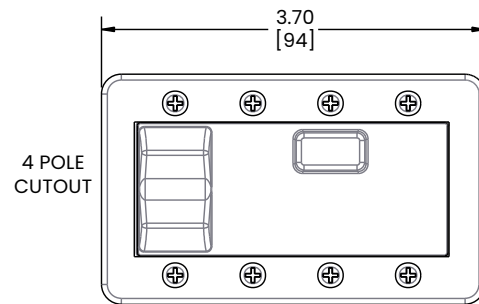

8PC-A4

Time Delay

Instantaneous

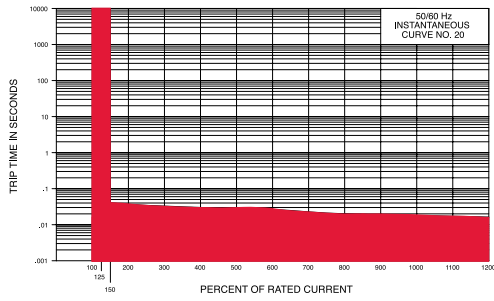

Medium

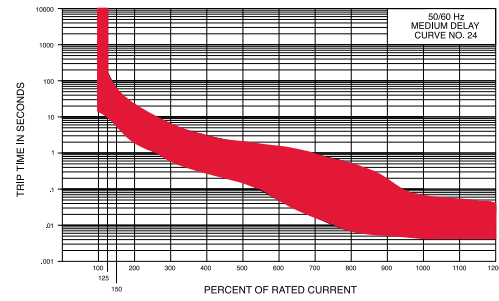

Ultra Short

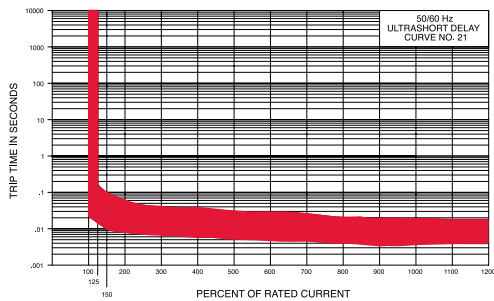

Long

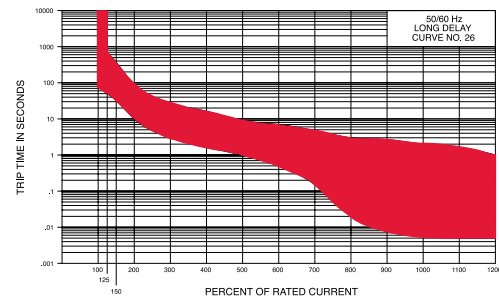

Short

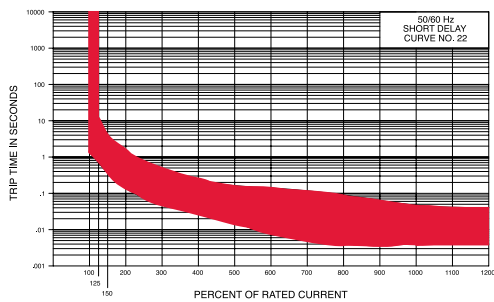

Time Delay Values									
Percent of Rated Current									
Delay	100%	125%	150%	200%	400%	600%	800%	1000%	1200%
20	No Trip	May Trip	.040 MAX	.035 MAX	.030 MAX	.025 MAX	.020 MAX	.017 MAX	.015 MAX
21	No Trip	.014 - .150	.011 - .095	.008 - .055	.006 - .035	.005 - .027	.005 - .021	.004 - .018	.004 - .017
22	No Trip	.700 - 12.0	.350 - 4.00	.130 - 1.30	.027 - .220	.008 - .130	.004 - .090	.004 - .045	.004 - .040
24	No Trip	10.0 - 160	6.00 - 60.0	2.20 - 20.0	3.00 - 3.00	.050 - 1.30	.007 - 5.00	.005 - 0.60	.005 - .040
26	No Trip	50.0 - 700	32.0 - 350	10.0 - 90.0	1.50 - 15.0	.500 - 7.00	.020 - 3.00	.006 - 2.00	.005 - 1.00

Notes:

Other time delay values available, consult factory.

Delay Curves 21,22,24,26: Breakers to hold 100% and must trip at 125% of rated current and greater within the time limit shown in this curve.

Delay Curve 20: Breakers to hold 100% and must trip at 150% of rated current and greater within the time limit shown in this curve.

All Curves: Curve data shown represents breaker response at ambient temperature of 77°F (25°C) with no preloading. Breakers are mounted in standard wall-mount position.

The minimum inrush pulse tolerance handling capability is 12 times the rated current. These values are based on a 60 Hz 1/2 cycle, 8.33 ms pulse.

Authorized Sales Representatives and Distributors

Click on a region of the map below to find your local representatives and distributors or visit www.carlingtech.com/findarep.



About Carling

Founded in 1920, Carling Technologies is a leading manufacturer of electrical and electronic switches and assemblies, circuit breakers, electronic controls, power distribution units, and multiplexed power distribution systems. With six ISO9001 and IATF16949 registered manufacturing facilities and technical sales offices worldwide, Carling Technologies Sales, Service and Engineering teams do much more than manufacture electrical components, they engineer powerful solutions! To learn more about Carling please visit www.carlingtech.com/company-profile.

To view all of Carling's environmental, quality, health & safety certifications please visit www.carlingtech.com/environmental-certifications.



European Headquarters

Carling Technologies LTD
4 Airport Business Park, Exeter Airport,
Clyst Honiton, Exeter, Devon, EX5 2UL, UK
Phone: Int + 44 1392.364422
Email: ltd.sales@carlingtech.com

Worldwide Headquarters

Carling Technologies Inc.
60 Johnson Avenue,
Plainville, CT 06062 USA
Phone: 860.793.9281
Email: sales@carlingtech.com

Asia-Pacific Headquarters

Carling Technologies, Asia-Pacific LTD.,
Suite 1607, 16/F Tower 2, The Gateway, Harbour City, 25
Canton Road, Tsimshatsui, Kowloon, Hong Kong
Phone: Int + 852-2737-2277
Email: sales@carlingtech.com.hk

WWW.CARLINGTECH.COM

