

NHD-10.1-1024600AF-LSXV#-CTP

TFT (Thin-Film-Transistor) Color Liquid Crystal Display Module

NHD-	Newhaven Display
10.1-	10.1" Diagonal
1024600-	1024xRGBx600 Pixels
AF-	Model
L-	LVDS Interface
S-	High Brightness, White LED Backlight
X-	TFT
V-	MVA, Standard Temperature
#-	RoHS Compliant
CTP-	Capacitive Touch Panel with Controller

Newhaven Display International, Inc.

2661 Galvin Ct.

Elgin IL, 60124

Ph: 847-844-8795

Fax: 847-844-8796

www.newhavendisplay.com

nhtech@newhavendisplay.com

nhsales@newhavendisplay.com

Document Revision History

Revision	Date	Description	Changed by
0	5/17/17	Initial Release	SB

Functions and Features

- 1024xRGBx600 resolution
- LED backlight
 - Built-in LED driver
 - PWM brightness control
- LVDS interface
 - 4 LVDS Channels
- 262K colors
- Wide Viewing Angles
- Capacitive touch panel with controller
 - 10 point multi-touch input
 - Gesture input
 - Zoom In/Out
 - Swipe Up/Down/Left/Right

Mechanical Drawing

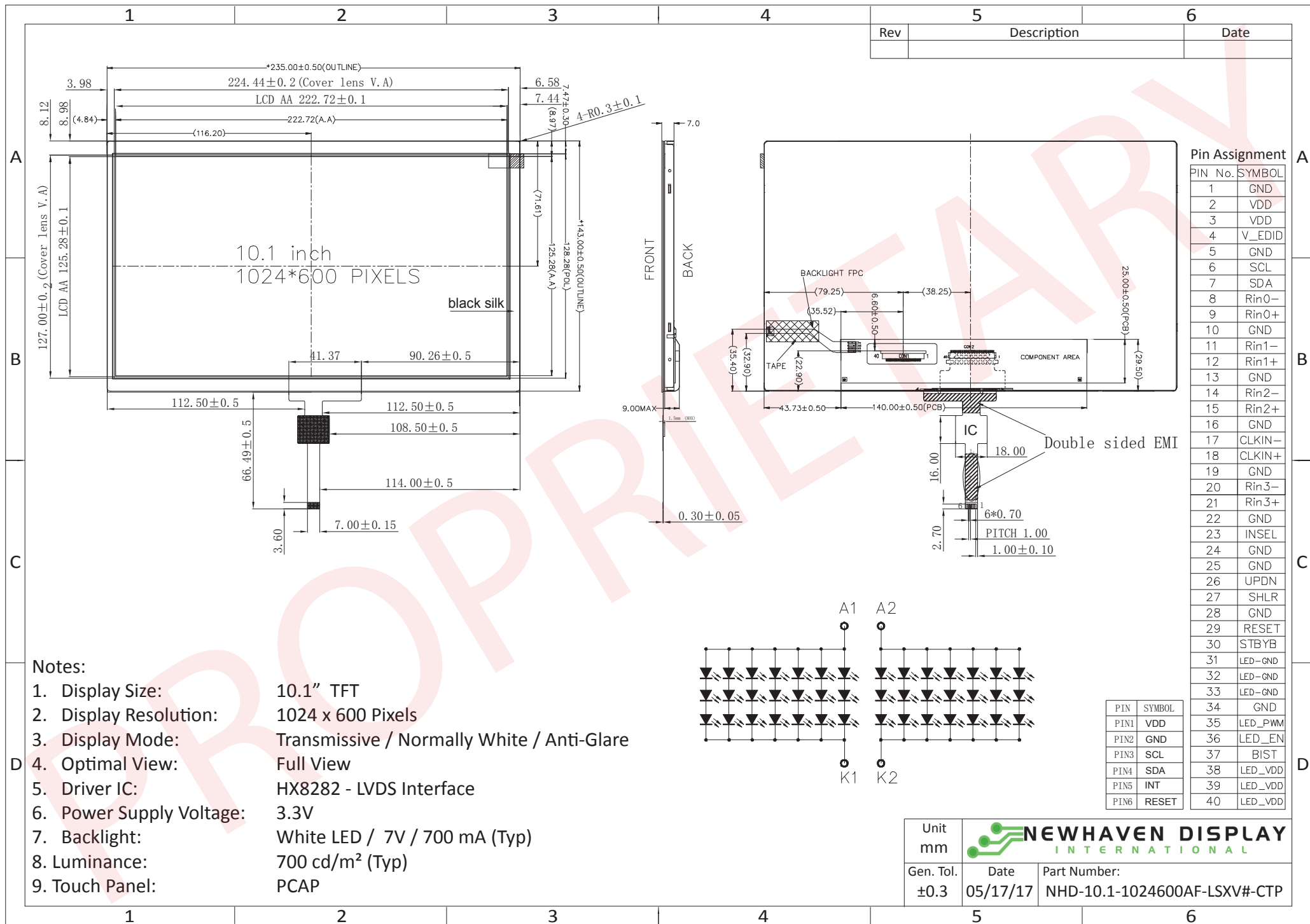

Pin Description

TFT:

Pin No.	Symbol	Connection	Function Description
1	GND	Power Supply	Ground
2-3	V _{DD}	Power Supply	Supply voltage for LCD (+3.3V)
4	V _{EDID}	Power Supply	Supply voltage for EDID (+3.3V)
5	GND	Power Supply	Ground
6	SCL	MPU	Serial Clock
7	SDA	MPU	Serial Data
8	Rin0-	MPU	-LVDS differential data input CH0
9	Rin0+	MPU	+LVDS differential data input CH0
10	GND	Power Supply	Ground
11	Rin1-	MPU	-LVDS differential data input CH1
12	Rin1+	MPU	+LVDS differential data input CH1
13	GND	Power Supply	Ground
14	Rin2-	MPU	-LVDS differential data input CH2
15	Rin2+	MPU	+LVDS differential data input CH2
16	GND	Power Supply	Ground
17	CLKIN-	MPU	-LVDS differential Clock
18	CLKIN+	MPU	+LVDS differential Clock
19	GND	Power Supply	Ground
20	Rin3-	MPU	-LVDS differential data input CH3
21	Rin3+	MPU	+LVDS differential data input CH3
22	GND	Power Supply	Ground
23	INSEL	MPU	Input Selection: INSEL = L 8-Bit, INSEL = H 6-Bit
24-25	GND	Power Supply	Ground
26	UPDN	MPU	Gate Driver Up/Down Scan Setting: UPDN = H: Reverse Scan UPDN = L: Normal Scan (Default)
27	SHLR	MPU	Source Driver Internal Shift Register Control: SHLR = H: SO1→SO2→SO3→...→SO1536. (Default) SHLR = L: SO1536→SO1535→SO1534→...→SO1
28	GND	Power Supply	Ground
29	RESET	MPU	Active Low Reset Signal
30	STBYB	MPU	Active Low Standby Signal
31-33	LED_GND	Power Supply	Backlight Cathode (Ground)
34	GND	Power Supply	Ground
35	LED_PWM	MPU	Backlight PWM Signal Input
36	LED_EN	MPU	Backlight Enable
37	BIST	MPU	Normal Operating/BIST Pattern Select BIST = H: BIST (Clock input not needed) BIST = L: Normal Operation (Default)
38-40	LED_V _{DD}	Power Supply	Backlight Anode

LCD connector: 0.5mm pitch 40-Conductor FFC.

Recommended cable: 40 POS FFC

Capacitive Touch Panel:

Pin No.	Symbol	External Connection	Function Description
1	VDD	Power Supply	Power Supply (3.3V)
2	GND	Power Supply	Ground
3	SCL	MPU	Serial I2C Clock (Requires pull-up resistor)
4	SDA	MPU	Serial I2C Data (Requires pull-up resistor)
5	/INT	MPU	Interrupt signal from touch panel module to host
6	/RESET	MPU	Active LOW Reset signal.

Recommended connector: 1.0mm pitch 6-Conductor FFC. Molex p/n: 52271-0679

Electrical Characteristics

Item	Symbol	Condition	Min.	Typ.	Max.	Unit
Operating Temperature Range	T _{OP}	Absolute Max	0	-	+50	°C
Storage Temperature Range	T _{ST}	Absolute Max	-20	-	+60	°C
Supply Voltage for LCD	V _{DD}	-	3.0	3.3	3.6	V
Supply Voltage for EDID	V _{EDID}	-	3.0	3.3	3.6	V
Supply Current for LCD	I _{DD}	V _{DD} = 3.3V	50	120	180	mA
"H" Level Input	V _{IH}	-	0.7 * V _{DD}	-	V _{DD}	V
"L" Level Input	V _{IL}	-	GND	-	0.3 * V _{DD}	V
"H" Level Output	V _{OH}	-	V _{DD} - 0.4	-	V _{DD}	V
"L" Level Output	V _{OL}	-	GND	-	GND + 0.4	V
Backlight Supply Voltage	V _{LED}	-	5	-	7	V
Backlight Supply Current	I _{LED}	V _{LED} = 7V	650	700	750	mA
Backlight Lifetime*	-	I _{LED} = 700 mA T _{OP} = 25° C	20,000	50,000	-	Hrs.

*Backlight lifetime is rated as Hours until **half-brightness**, under normal operating conditions.

Capacitive Touch Panel:

Item	Symbol	Condition	Min.	Typ.	Max.	Unit
Operating Temperature Range	T _{OP}	Absolute Max	-20	-	+70	°C
Storage Temperature Range	T _{ST}	Absolute Max	-30	-	+80	°C
Supply Voltage	V _{DD}	-	3.0	3.3	3.6	V
Supply Current – Operating	I _{DD}	T _{OP} =25°C, V _{DD} =3.3V	-	6.0	-	mA
Supply Current – Hibernate	I _{DD}		-	1.0	-	µA
"H" Level Input	V _{OH}	-	0.7 * V _{DD}	-	V _{DD}	V
"L" Level Input	V _{IL}	-	V _{SS}	-	0.3 * V _{DD}	V
"H" Level Output	V _{OH}	-	0.7 * V _{DD}	-	V _{DD}	V
"L" Level Output	V _{OH}	-	V _{SS}	-	0.3 * V _{DD}	V

Optical Characteristics

Item	Symbol	Condition	Min.	Typ.	Max.	Unit	
Optimal Viewing Angles	Top	CR ≥10	-	75	-	°	
	Bottom		-	75	-	°	
	Left		-	75	-	°	
	Right		-	75	-	°	
Contrast Ratio	CR	-	450	750	-	-	
Luminance	L _V	I _{LED} = 700mA	500	700	820	cd/m ²	
Response Time	Rise + Fall	T _R + T _F	T _{OP} = 25°C	-	8	-	ms
Chromaticity	Red	X _R	-	0.565	0.605	0.635	-
		Y _R	-	0.309	0.349	0.379	-
	Green	X _G	-	0.286	0.326	0.356	-
		Y _G	-	0.565	0.605	0.635	-
	Blue	X _B	-	0.112	0.152	0.182	-
		Y _B	-	0.075	0.115	0.145	-
White	X _W	-	0.257	0.297	0.327	-	
	Y _W	-	0.283	0.323	0.353	-	

LED_PWM Signal Operating Frequency:

PWM Frequency (F)	Duty Cycle (Min.)	Duty Cycle (Max.)
100Hz < F < 500Hz	5%	100%
500Hz < F < 20KHz	10%	100%

Capacitive Touch Panel Material Characteristics:

Property	Requirement	Unit
Surface Hardness	≥6	H
Light transmission	≥82%	-
Operating Humidity	20~85%	RH
Storage Humidity	20~85%	RH

Driver Information

Built-in HX8282-A14 Source Driver: <http://www.newhavendisplay.com/appnotes/datasheets/LCDs/HX8282-A01.pdf>

Built-in HX8696-A00 Gate Driver: <http://www.newhavendisplay.com/appnotes/datasheets/LCDs/HX8696-A.pdf>

Capacitive Touch Panel:

Built-in FocalTech FT5526EEZ controller.

Please download specification at <http://www.newhavendisplay.com/appnotes/datasheets/touchpanel/FT5x26.pdf>

Capacitive Touch Panel Registers

Address	Name	B7	B6	B5	B4	B3	B2	B1	B0	Access	
00h	DEVICE_MODE	Device Mode [2..0]									R/W
01h	GEST_ID	Gesture ID [7..0]								R	
02h	TD_STATUS							Touch Points [3..0]			R
03h	TOUCH1_XH	Event Flag			1st Touch X Position MSB [11..8]					R	
04h	TOUCH1_XL	1st Touch X Position LSB [7..0]								R	
05h	TOUCH1_YH	Touch ID [3..0]			1st Touch Y Position MSB [11..8]					R	
06h	TOUCH1_YL	1st Touch Y Position LSB [7..0]								R	
07h										R	
08h										R	
09h	TOUCH2_XH	Event Flag			2nd Touch X Position MSB [11..8]					R	
0Ah	TOUCH2_XL	2nd Touch X Position LSB [7..0]								R	
0Bh	TOUCH2_YH	Touch ID [3..0]			2nd Touch Y Position MSB [11..8]					R	
0Ch	TOUCH2_YL	2nd Touch Y Position LSB [7..0]								R	
0Dh										R	
0Eh										R	
0Fh	TOUCH3_XH	Event Flag			3rd Touch X Position MSB [11..8]					R	
10h	TOUCH3_XL	3rd Touch X Position LSB [7..0]								R	
11h	TOUCH3_YH	Touch ID [3..0]			3rd Touch Y Position MSB [11..8]					R	
12h	TOUCH3_YL	3rd Touch Y Position LSB [7..0]								R	
13h										R	
14h										R	
15h	TOUCH4_XH	Event Flag			4th Touch X Position MSB [11..8]					R	
16h	TOUCH4_XL	4th Touch X Position LSB [7..0]								R	
17h	TOUCH4_YH	Touch ID [3..0]			4th Touch Y Position MSB [11..8]					R	
18h	TOUCH4_YL	4th Touch Y Position LSB [7..0]								R	
19h										R	
1Ah										R	
1Bh	TOUCH5_XH	Event Flag			5th Touch X Position MSB [11..8]					R	
1Ch	TOUCH5_XL	5th Touch X Position LSB [7..0]								R	
1Dh	TOUCH5_YH	Touch ID [3..0]			5th Touch Y Position MSB [11..8]					R	
1Eh	TOUCH5_YL	5th Touch Y Position LSB [7..0]								R	
1Fh										R	

Address	Name	B7	B6	B5	B4	B3	B2	B1	B0	Access	
80h	ID_G_THGROUP	valid touching detect threshold								R/W	
81h	ID_G_THPEAK	valid touching peak detect threshold								R/W	
82h	ID_G_THCAL	the threshold when calculating the focus of touching								R/W	
83h	ID_G_THWATER	the threshold when there is surface water								R/W	
84h	ID_G_TEMP	the threshold of temperature compensation								R/W	
85h	ID_G_THDIFF	the threshold whether the coordinate is different from original								R/W	
86h	ID_G_CTRL						Power Control Mode [1..0]				R/W
87h	ID_G_TIME_ENTER_MONITOR	the timer for entering monitor status								R/W	
88h	ID_G_PERIODACTIVE						Period Active [3..0]				R/W
89h	ID_G_PERIODMONITOR	the timer of entering idle when in monitor status								R/W	
A0h	ID_G_AUTO_CLB_MODE	auto calibration mode								R/W	
A1h	ID_G_LIB_VERSION_H	Firmware Library Version H byte								R	
A2h	ID_G_LIB_VERSION_L	Firmware Library Version L byte								R	
A3h	ID_G_CIPHER	Chip vendor ID								R	
A4h	ID_G_MODE	the interrupt status to host								R	
A5h	ID_G_PMODE	Power Consume Mode									
A6h	ID_G_FIRMID	Firmware ID								R	
A7h	ID_G_STATE	Running State									
A8h	ID_G_FT5201ID	CTPM Vendor ID								R	
A9h	ID_G_ERR	Error Code								R	
AAh	ID_G_CLB	Configure TP module during calibration in Test Mode								R/W	
FEh	LOG_MSG_CNT	The log MSG count								R	
FFh	LOG_CUR_CHA	Current character of log message								R	

NOTE: Registers 80h – AFh have been configured for optimum settings and do not need to be modified.

Register No	Register Name	Bits	Value	Description
00h	Device Mode	[2:0]	000b 100b 001b	Normal Operating Mode Test Mode - read raw data (reserved) System Information Mode (reserved)
01h	Gesture ID	[7:0]	48h 49h 00h	Zoom In Zoom Out No Gesture
02h	Touch Points	[3:0]	000b 001b 010b 011b 100b 101b	0 touch points detected 1 touch point detected 2 touch points detected 3 touch points detected 4 touch points detected 5 touch points detected
03h	Touch 1 Event Flag	[7:6]	00b 01b 10b 11b	Put Down Put Up Contact Reserved
03h	TOUCH1_XH	[3:0]	0h - 1h	Upper 4 bits of X touch coordinate
04h	TOUCH1_XL	[7:0]	00h - FFh	Lower 8 bits of X touch coordinate
05h	TOUCH1_YH	[3:0]	0h - 1h	Upper 4 bits of Y touch coordinate
06h	TOUCH1_YL	[7:0]	00h - FFh	Lower 8 bits of Y touch coordinate
09h	Touch 2 Event Flag	[7:6]	00b 01b 10b 11b	Put Down Put Up Contact Reserved
09h	TOUCH2_XH	[3:0]	0h - 1h	Upper 4 bits of X touch coordinate
0Ah	TOUCH2_XL	[7:0]	00h - FFh	Lower 8 bits of X touch coordinate
0Bh	TOUCH2_YH	[3:0]	0h - 1h	Upper 4 bits of Y touch coordinate
0Ch	TOUCH2_YL	[7:0]	00h - FFh	Lower 8 bits of Y touch coordinate
0Fh	Touch 3 Event Flag	[7:6]	00b 01b 10b 11b	Put Down Put Up Contact Reserved
0Fh	TOUCH3_XH	[3:0]	0h - 1h	Upper 4 bits of X touch coordinate
10h	TOUCH3_XL	[7:0]	00h - FFh	Lower 8 bits of X touch coordinate
11h	TOUCH3_YH	[3:0]	0h - 1h	Upper 4 bits of Y touch coordinate
12h	TOUCH3_YL	[7:0]	00h - FFh	Lower 8 bits of Y touch coordinate
15h	Touch 4 Event Flag	[7:6]	00b 01b 10b 11b	Put Down Put Up Contact Reserved
15h	TOUCH4_XH	[3:0]	0h - 1h	Upper 4 bits of X touch coordinate
16h	TOUCH4_XL	[7:0]	00h - FFh	Lower 8 bits of X touch coordinate
17h	TOUCH4_YH	[3:0]	0h - 1h	Upper 4 bits of Y touch coordinate
18h	TOUCH4_YL	[7:0]	00h - FFh	Lower 8 bits of Y touch coordinate

Register No	Register Name	Bits	Value	Description
1Bh	Touch 5 Event Flag	[7:6]	00b 01b 10b 11b	Put Down Put Up Contact Reserved
1Bh	TOUCH5_XH	[3:0]	0h - 1h	Upper 4 bits of X touch coordinate
1Ch	TOUCH5_XL	[7:0]	00h - FFh	Lower 8 bits of X touch coordinate
1Dh	TOUCH5_YH	[3:0]	0h - 1h	Upper 4 bits of Y touch coordinate
1Eh	TOUCH5_YL	[7:0]	00h - FFh	Lower 8 bits of Y touch coordinate
80h	ID_G_THGROUP	[7:0]	00h - FFh	Valid touching detect threshold Actual value will be 4 times register's value Recommended: 46h
81h	ID_G_THPEAK	[7:0]	00h - FFh	valid touching peak detect threshold Recommended: 3Ch
82h	ID_G_THCAL	[7:0]	00h - FFh	Touch focus threshold Recommended: 1Dh
83h	ID_G_THWATER	[7:0]	00h - FFh	threshold when there is surface water Recommended: D3h
84h	ID_G_THTEMP	[7:0]	00h - FFh	threshold of temperature compensation Recommended: EBh
85h	ID_G_THDIFF	[7:0]	00h - FFh	Touch difference threshold Actual value is 32 times the register's value Recommended: A0h
86h	ID_G_CTRL	[1:0]	00h 01h	Power Control Mode: Not Auto Jump Power Control Mode: Auto Jump
87h	ID_G_TIME_ENTER_MONITOR	[7:0]	00h-FFh	Delay to enter 'Monitor' status (s) Recommended: C8h
88h	ID_G_PERIODACTIVE	[3:0]	3h-Eh	Period of 'Active' status (ms) Recommended: 6h
89h	ID_G_PERIODMONITOR	[7:0]	1Eh-FFh	Timer to enter 'idle' when in 'Monitor' (ms) Recommended: 28h
A0h	ID_G_AUTO_CLB_MODE	[7:0]	00h FFh	Auto calibration mode: Enable auto calibration Auto calibration mode: Disable auto calibration
A1h	ID_G_LIB_VERSION_H	[7:0]	30h	Firmware Library Version H byte
A2h	ID_G_LIB_VERSION_L	[7:0]	01h	Firmware Library Version L byte
A3h	ID_G_CIPHER	[7:0]	54h	Chip vendor ID
A4h	ID_G_MODE	[0:0]	00h 01h	Interrupt status: Enable interrupt to host Interrupt status: Disable interrupt to host
A5h	ID_G_PMODE	[1:0]	00h 01h 03h	'Active' Mode 'Monitor' Mode 'Hibernate' Mode
A6h	ID_G_FIRMID	[7:0]	06h	Firmware ID
A7h	ID_G_STATE	[7:0]	00h 01h 02h 03h 04h	Running State: Configure Running State: Work Running State: Calibration Running State: Factory Running State: Auto-calibration
A8h	ID_G_FT5201ID	[7:0]	79h	CTPM Vendor's Chip ID
A9h	ID_G_ERR	[7:0]	00h 03h 05h 1Ah	Error Code: OK Error Code: Chip register writing inconsistent with reading Error Code: Chip start fail Error Code: Calibration match fail

Timing Characteristics

Parameter	Symbol	Spec			Unit	Condition
		Min.	Typ.	Max.		
Clock frequency	R_{XFCLK}	20	-	71	MHz	-
Input data skew margin	T_{RSKM}	500	-	-	pS	$ VID = 400mV$ $R_{XVCM} = 1.2V$ $R_{XFCLK} = 71MHz$
Clock high time	T_{LVCH}	-	$4/(7 * RXFCLK)$	-	nS	-
Clock low time	T_{LVCL}	-	$3/(7 * RXFCLK)$	-	nS	-
PLL wake-up time	T_{emPLL}	-	-	150	μS	-

Parameter	Symbol	Spec			Unit	Condition
		Min.	Typ.	Max.		
Modulation Frequency	SSC_{MF}	23	-	93	KHz	-
Modulation Rate	SSC_{MR}	-	-	± 3	%	LVDS Clock = 71 MHz

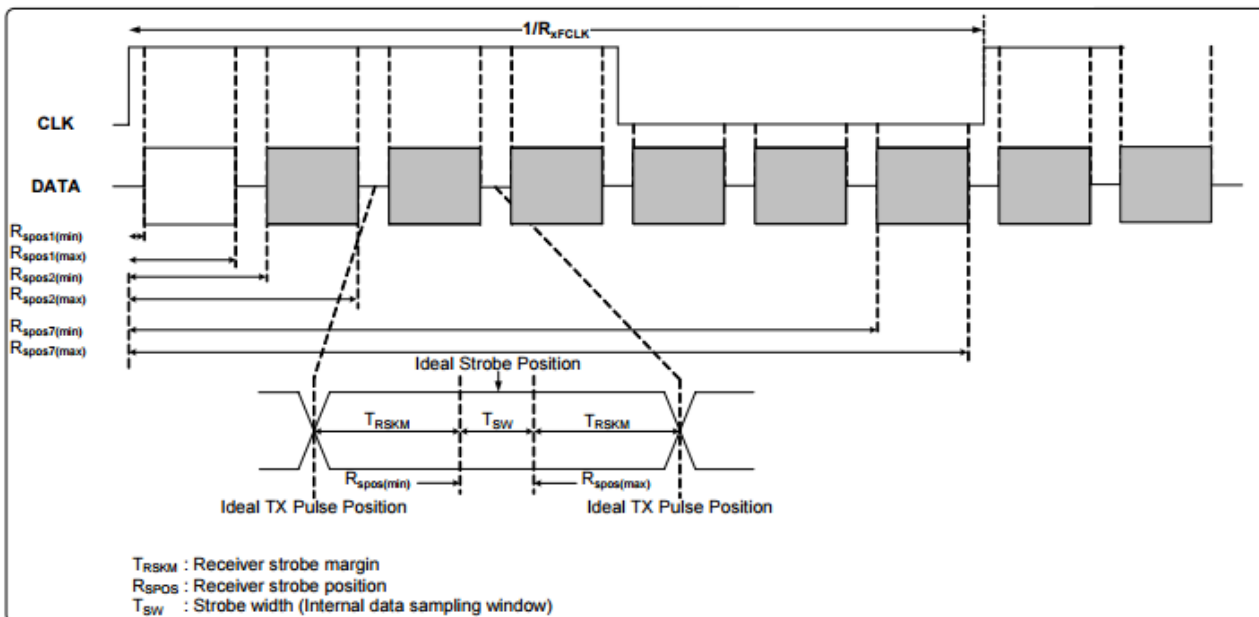
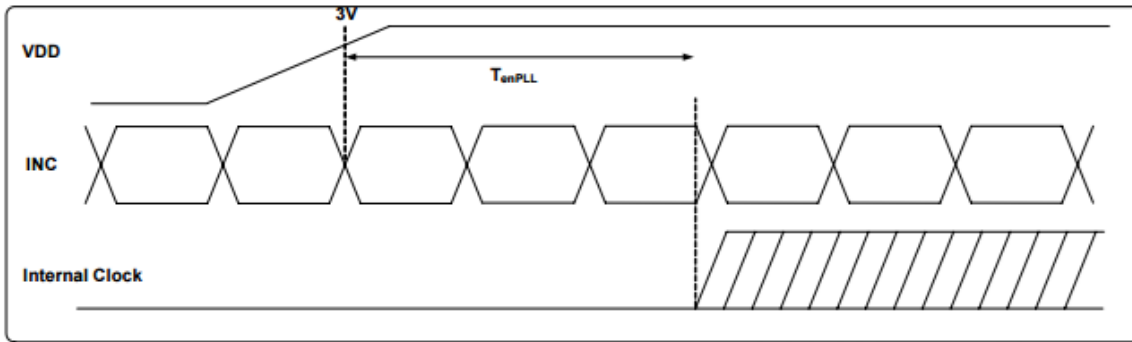
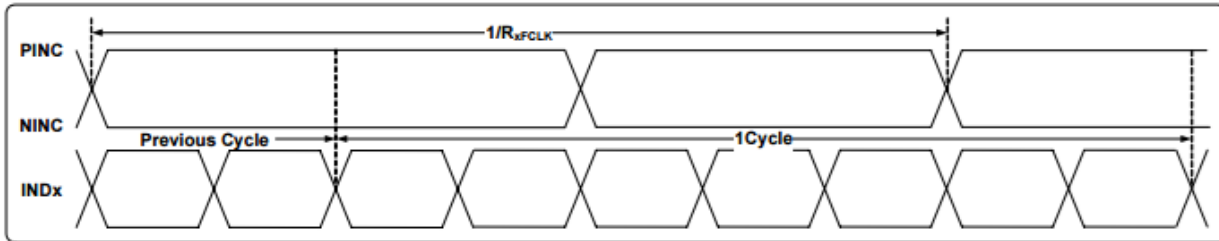

6-bit LVDS data input format:

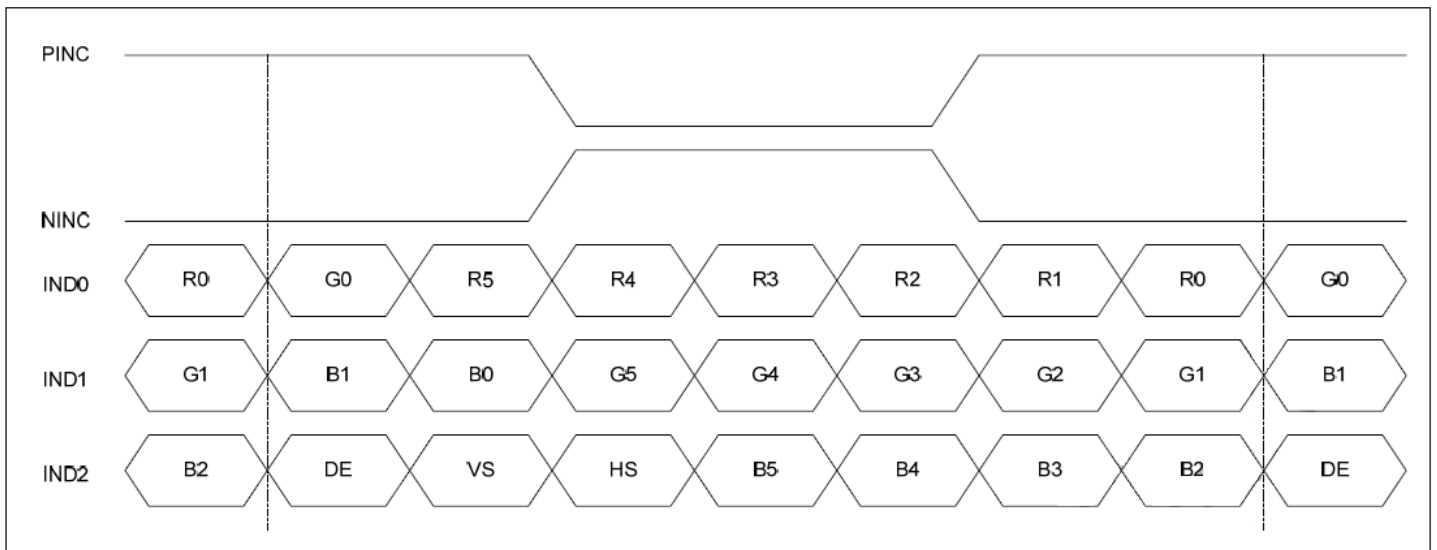

8-Bit LVDS Data Input Format:

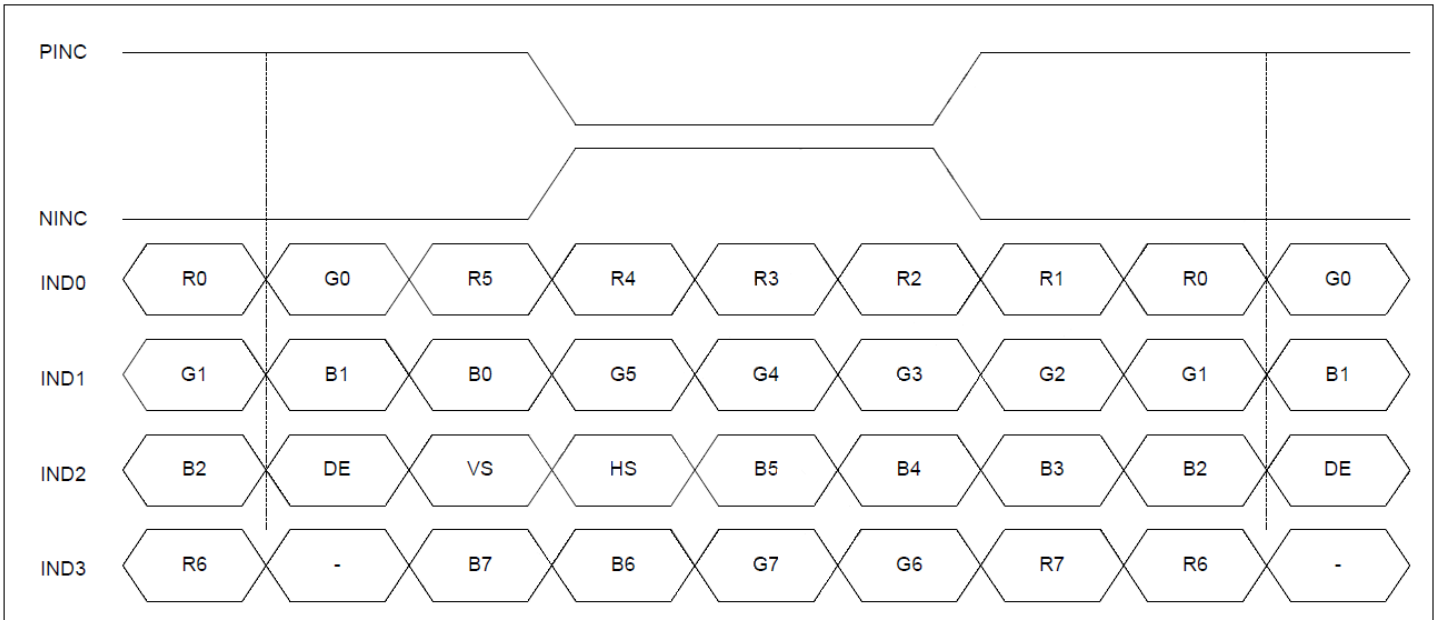

CTP Timing:

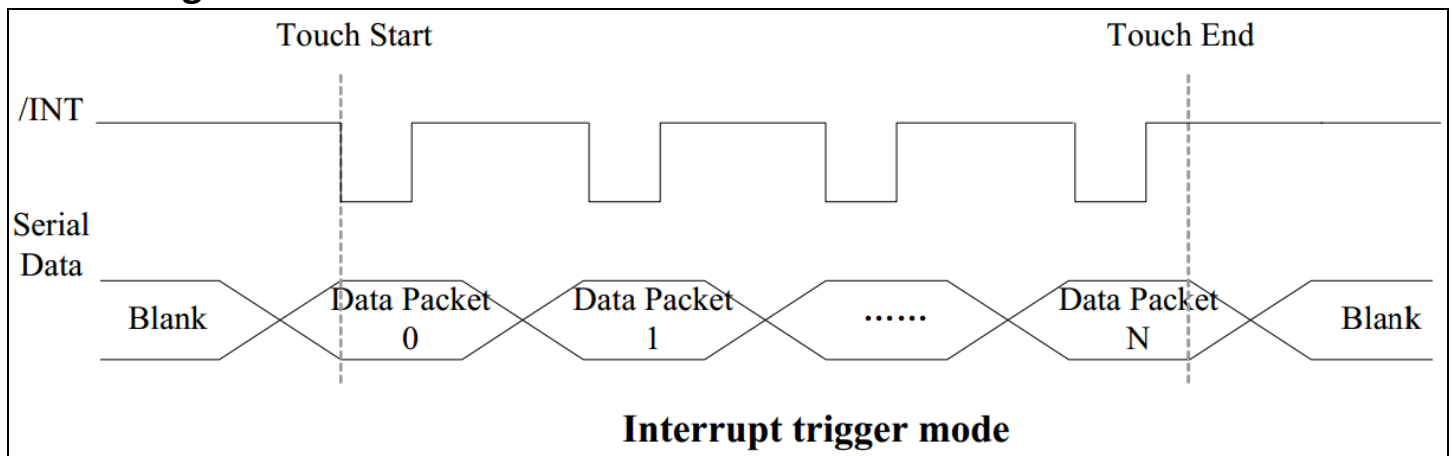

Sample code to read touch data:

```
i2c_start();
i2c_tx(0x70);           //Slave Address (Write)
i2c_tx(0x00);           //Start reading address
i2c_stop();

i2c_start();
i2c_tx(0x71);           //Slave Address (Read)
for(i=0x00;i<0x1F;i++)
{touchdata_buffer[i] = i2c_rx(1);}
i2c_stop();
```

Sample code to overwrite default register values:

```
i2c_start();
i2c_tx(0x70);           //Slave Address (Write)
i2c_tx(0xA4);           //ID_G_Mode
i2c_tx(0x01);           //Disable interrupt status to host
i2c_stop();
```

Quality Information

Test Item	Content of Test	Test Condition	Note
High Temperature storage	Endurance test applying the high storage temperature for a long time.	+60°C , 240 hrs.	2
Low Temperature storage	Endurance test applying the low storage temperature for a long time.	-20°C , 240 hrs.	1,2
High Temperature Operation	Endurance test applying the electric stress (voltage & current) and the high thermal stress for a long time.	+50°C, 120 hrs.	2
Low Temperature Operation	Endurance test applying the electric stress (voltage & current) and the low thermal stress for a long time.	0°C , 120 hrs.	1,2
High Temperature / Humidity Operation	Endurance test applying the electric stress (voltage & current) and the high thermal with high humidity stress for a long time.	+50°C , 85% RH , 120 hrs.	1,2
Thermal Shock resistance	Endurance test applying the electric stress (voltage & current) during a cycle of low and high thermal stress.	0°C, 30min->25°C, 5min -> 50°C, 30min 10 cycles	
Vibration test	Endurance test applying vibration to simulate transportation and use.	10-55Hz , 1.5mm amplitude. 60 sec in each of 3 directions X,Y,Z For 15 minutes	3
Static electricity test	Endurance test applying electric static discharge.	Air: V _s =8KV, Contact: V _s =4KV 10 Times	

Note 1: No condensation to be observed.

Note 2: Conducted after 4 hours of storage at 25°C, 0%RH.

Note 3: Test performed on product itself, not inside a container.

Precautions for using LCDs/LCMs

See Precautions at www.newhavendisplay.com/specs/precautions.pdf

Warranty Information and Terms & Conditions

http://www.newhavendisplay.com/index.php?main_page=terms