

60X60X25 mm

JF0625-00 Series



- **Frame** : Plastic Material UL 94V-0
- **Impeller** : Plastic Material UL 94V-0
- **Speed Range** : $\pm 10\%$

SPECIFICATIONS											
Model	Bearing	Rated Voltage (V)	Operating Voltage (V)	Air Flow (CFM)	Static Pressure (inchH ₂ O)	Speed (R.P.M.)	Input Current (Amp)	Input Power (Watt)	Nominal Current (Amp)	Noise (dBA)	Weight (g)
JF0625B1TR00	Dual Ball	12	10.2 ~ 13.8	29.69	0.422	6000	0.37	4.44	0.38	42.5	65
JF0625B1UR00	Dual Ball			26.96	0.357	5500	0.29	3.48	0.30	39.6	
JF0625-1S-00	B, S			24.27	0.292	5000	0.22	2.64	0.22	35.7	
JF0625-1H-00	B, S			21.44	0.237	4500	0.20	2.40	0.23	34.1	
JF0625-1M-00	B, S			19.00	0.185	4000	0.16	1.92	0.20	31.3	
JF0625-1L-00	B, S			16.76	0.145	3500	0.13	1.56	0.17	27.3	
JF0625-1E-00	B, S			14.24	0.108	3000	0.11	1.32	0.11	22.4	
JF0625-1V-00	B, S			11.72	0.076	2500	0.08	0.96	0.08	20.2	
JF0625B2TR00	Dual Ball			24	20.4 ~ 27.6	29.69	0.422	6000	0.20	4.80	
JF0625B2UR00	Dual Ball	26.96	0.357			5500	0.16	3.84	0.16	39.6	
JF0625-2S-00	B, S	24.27	0.292			5000	0.13	3.12	0.14	35.7	
JF0625-2H-00	B, S	21.44	0.237			4500	0.12	2.88	0.17	34.1	
JF0625-2M-00	B, S	19.00	0.185			4000	0.11	2.64	0.13	31.3	
JF0625-2L-00	B, S	16.76	0.145			3500	0.10	2.40	0.12	27.3	
JF0625-2E-00	B, S	14.24	0.108			3000	0.07	1.68	0.07	22.4	
JF0625-2V-00	B, S	11.72	0.076			2500	0.06	1.44	0.06	20.2	
JF0625B4SR00	Dual Ball	48	40.8 ~ 60.0			24.27	0.292	5000	0.09	4.32	
JF0625B4HR00	Dual Ball			21.44	0.237	4500	0.07	3.36	0.08	34.1	
JF0625B4MR00	Dual Ball			19.00	0.185	4000	0.06	2.88	0.07	31.3	
JF0625B4LR00	Dual Ball			16.76	0.145	3500	0.05	2.40	0.06	27.3	

Specifications subject to change without notice

The 7TH character of Model No means the bearing code. Please refer to the page "PART NUMBER SYSTEM". Please contact us for detail if your request bearing system is not shown in the above list.

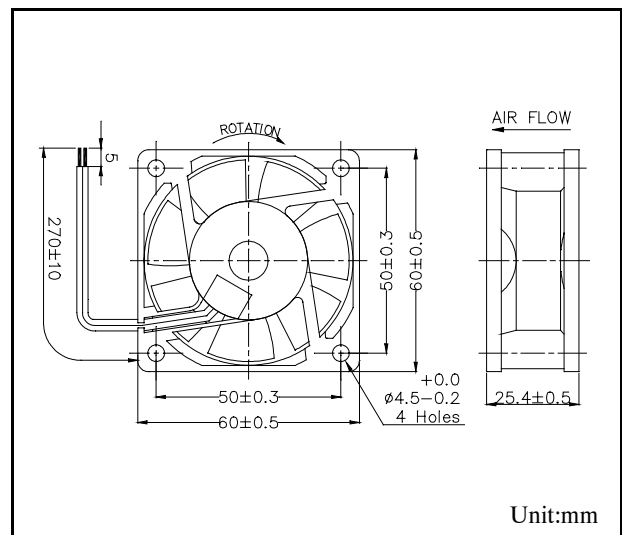
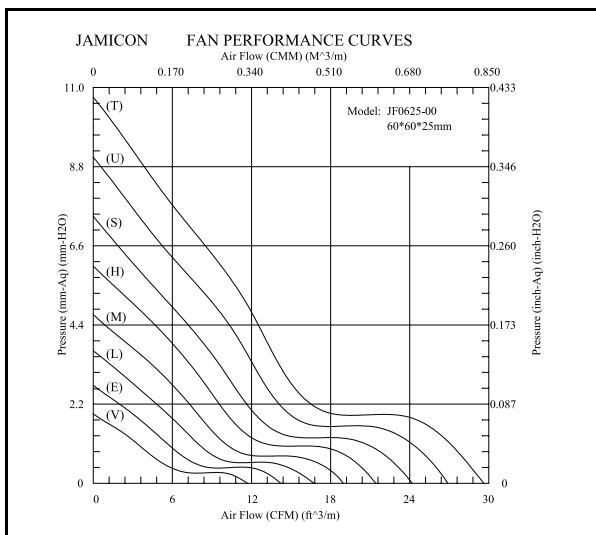

Part Number System

