

Illuminated Switches/Pilot Lights

AG22 and AG23

General information

■ Description

AG series Command Switches are designed to be installed in a square or rectangular hole. AG23 series are 25 x 32mm rectangular type while AG22 series are 25mm regular square type. Either of them comprises illuminated pushbutton switch and pilot light. The illuminated pushbutton switches are available either in momentary action or alternative action. Moreover, their light sources are also available in either incandescent lamp or LED lamp. These AG series Command Switches are highly suitable for use with instrumentation panels or control panels. Their contacts use Au-flashed Ag contacts and adopt a sliding mechanism, thus ensuring a high contact reliability. The color inserts for indicators are available up to 4-way split types. Each indicator is provided with 5-color inserts and the color you desire can be easily replace.

■ Features

• Excellent contact reliability

These switches combine Au-flashed Ag contact and sliding mechanism features so as to ensure a high contact reliability even when used with low-voltage, small current circuits of 5V 1mA range. Therefore, they allow direct input to IC's. Moreover, their contacts are a double-break type, thus permitting their application to 240V AC circuits.

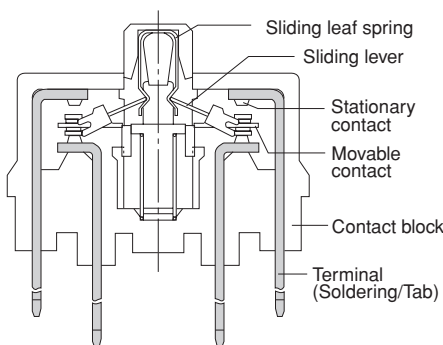

• Terminals are both use of soldering and tab terminal types

They are subjected to "solder plated" so as to permit accurate soldering.

• Contact can be added or replaced

The contact block comprises 1NO and 1NC. In AG23 series the contact arrangement is available up to 4NO+4NC and in AG22 series up to 2NO+2NC.

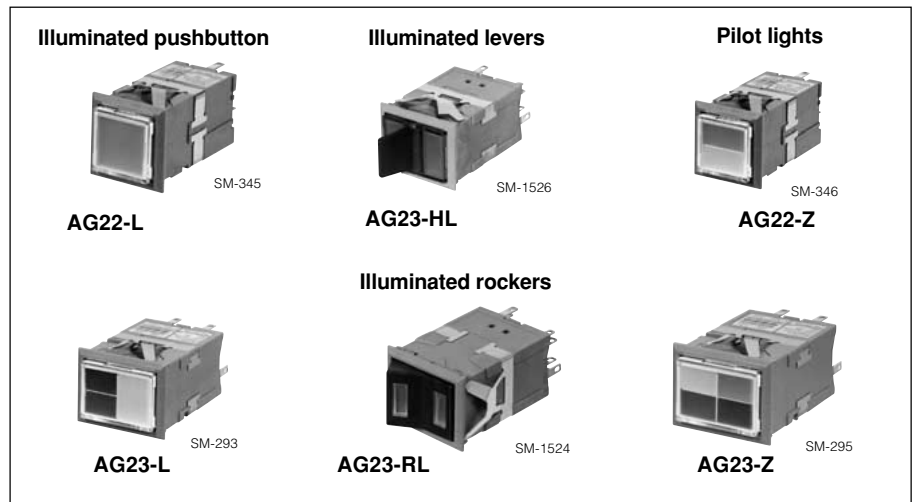

• Small in depth and compactly built

Both AG22 and AG23 series Command Switches are as small as 52mm in depth and their buttons are extruded only 5mm from the panel surface.

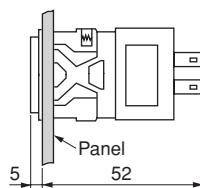

• The color inserts are available in max. 4-way split

The 4-color inserts can be positioned in any of the four quarters of the total display area. 6 combinations are available.

In these switches with incandescent lamp, their lens colors can be replaced with one from the "colored plate kit" which is provided for illuminated pushbutton switches or pilot lights.

■ Construction

AG23 (Incandescent lamp)

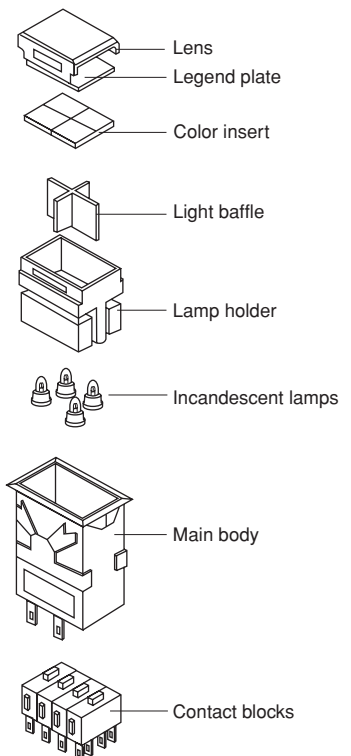

■ Approvals



For further information related to approved type, see page 04CD/1/2 to 04CD/1/3.





Illuminated Switches/Pilot Lights

AG22 and AG23





Quick reference guide

AG22 series

■ Illuminated pushbutton switches Incandescent lamp

Indicator split See page 04CD/1/8	
A: <input type="checkbox"/>	B: <input type="checkbox"/>
AG22-LAX   SP-1099	AG22-LBX   SP-1120





LED lamp: Indicators

Indicator split See page 04CD/1/9	
A: <input type="checkbox"/>	B: <input type="checkbox"/>
AG22-LA□3   SP-1101	AG22-LB□3   SP-1121





LED lamp: Contact unit

AG22-L□	See page 04CD/1/9
	 SP-1100

■ Pilot lights Incandescent lamp

Indicator split See page 04CD/1/8	
A: <input type="checkbox"/>	B: <input type="checkbox"/>
AG22-ZAX   SP-1099	AG22-ZBX   SP-1120

LED lamp: Indicators













Indicator split See page 04CD/1/9	
A: <input type="checkbox"/>	B: <input type="checkbox"/>
AG22-ZA□3   SP-1101	AG22-ZB□3   SP-1121

LED lamp: Contact socket













AG22-Z6	See page 04CD/1/9
	 SP-1100

AG23 series

■ Illuminated pushbutton switches Incandescent lamp

Indicator split See page 04CD/1/8					
A: <input type="checkbox"/>	B: <input type="checkbox"/>	C: <input type="checkbox"/>	D: <input type="checkbox"/>	E: <input type="checkbox"/>	F: <input type="checkbox"/>
AG23-LAX   SP-1102	AG23-LBX   SP-1105	AG23-LCX   SP-1116	AG23-LDX   SP-1114	AG23-LEX   SP-1112	AG23-LFX   SP-1118

LED lamp: Indicators







Indicator split See page 04CD/1/9					
A: <input type="checkbox"/>	B: <input type="checkbox"/>	C: <input type="checkbox"/>	D: <input type="checkbox"/>	E: <input type="checkbox"/>	F: <input type="checkbox"/>
AG23-LA□3   SP-1122	AG23-LB□3   SP-1104	AG23-LC□3   SP-1117	AG23-LD□3   SP-1115	AG23-LE□3   SP-1113	AG23-LF□3   SP-1119

LED lamp: Contact unit







AG23-L□	See page 04CD/1/9
	 SP-1103

Illuminated Switches/Pilot Lights AG22 and AG23 Quick reference guide

■ Pilot lights Incandescent lamp

Indicator split						<i>See page 04CD/1/8</i>
A: <input type="checkbox"/>	B: <input type="checkbox"/>	C: <input type="checkbox"/>	D: <input type="checkbox"/>	E: <input type="checkbox"/>	F: <input type="checkbox"/>	
AG23-ZAX  SP-1102	AG23-ZBX  SP-1105	AG23-ZCX  SP-1116	AG23-ZDX  SP-1114	AG23-ZEX  SP-1112	AG23-ZFX  SP-1118	



LED lamp: Indicators

Indicator split						<i>See page 04CD/1/9</i>
A: <input type="checkbox"/>	B: <input type="checkbox"/>	C: <input type="checkbox"/>	D: <input type="checkbox"/>	E: <input type="checkbox"/>	F: <input type="checkbox"/>	
AG23-ZA□ 3  SP-1112	AG23-ZB□ 3  SP-1104	AG23-ZC□ 3  SP-1117	AG23-ZD□ 3  SP-1115	AG23-ZE□ 3  SP-1113	AG23-ZF□ 3  SP-1119	



LED lamp: Socket

AG23-Z6	<i>See page 04CD/1/9</i>
 SP-1103	

■ Illuminated lever switches

2-position	3-position	<i>See page 04CD/1/10</i>
Maintained, Spring return	Spring/manual return	
AG23-HL □  SP-1108	AG23-HL □  SP-1108	

■ Illuminated rocker switches

2-position	3-position	<i>See page 04CD/1/11</i>
Maintained, Spring return	Spring/manual return	
AG23-RL □  SP-1107	AG23-RL □  SP-1107	

Illuminated Switches/Pilot Lights

AG22 and AG23

Type number nomenclature

■ Type number nomenclature

• Illuminated pushbutton switch (Incandescent lamp)

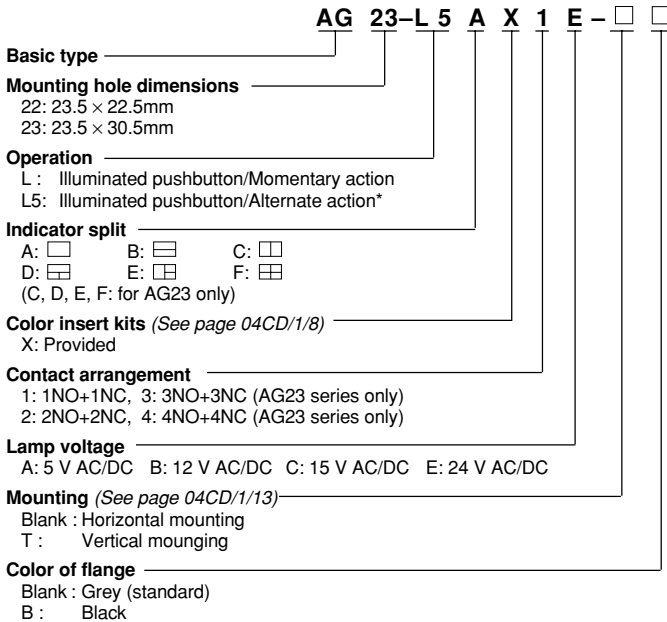

• Illuminated pushbutton switch (LED lamp)

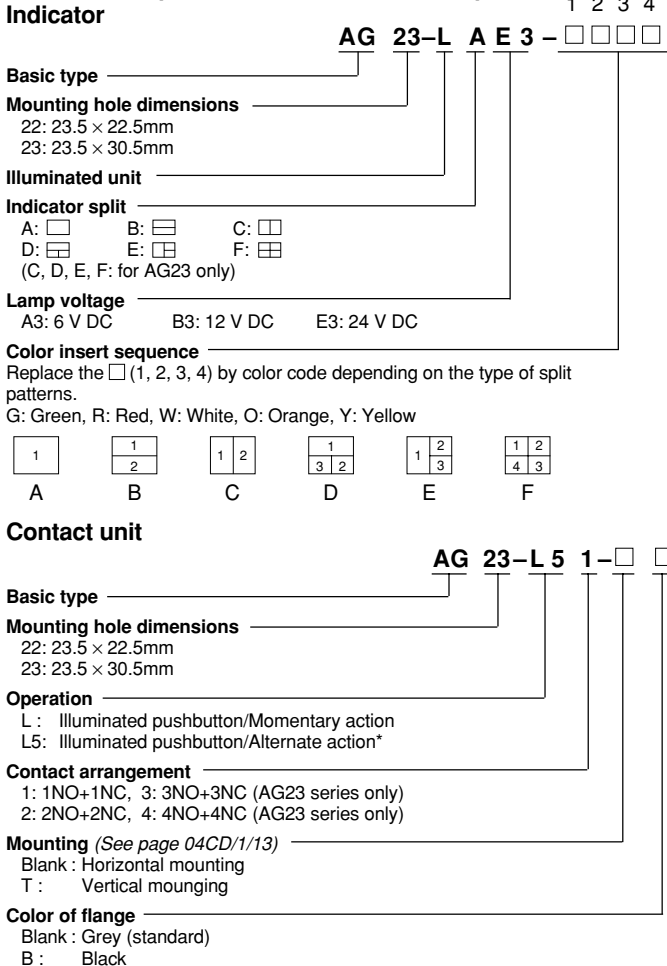

• Pilot light (Incandescent lamp)

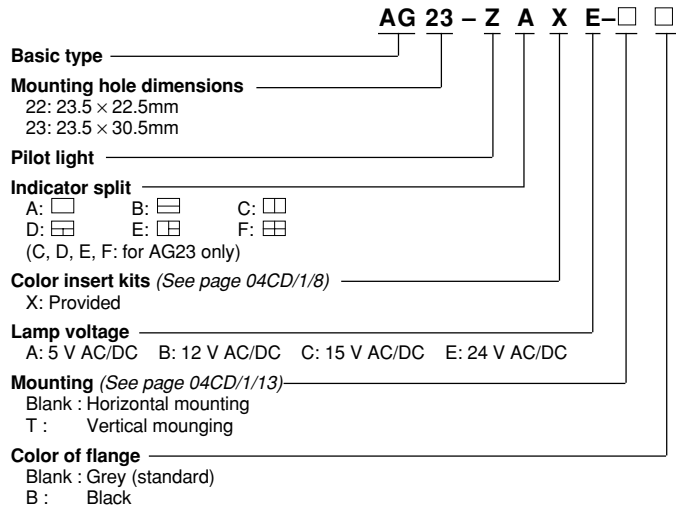

• Pilot light (LED lamp)

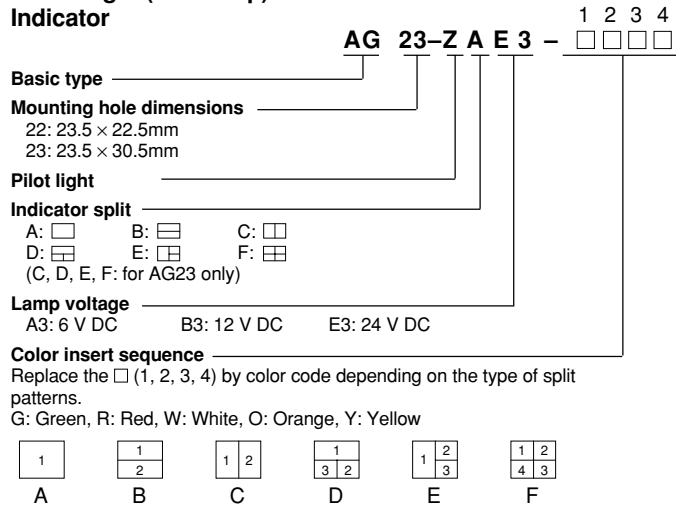

Socket

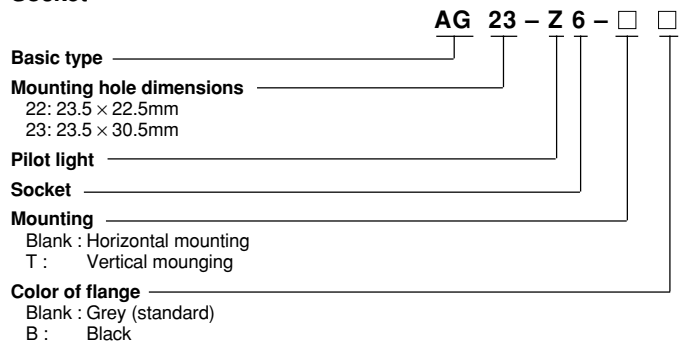

Notes: * When the button is depressed the contacts are maintained and remain so even if the finger is removed. The button will not return to its free position. In order to remove the lock, the button must be given a second pressure before the button will return to its free position.

Illuminated Switches/Pilot Lights

AG22 and AG23

Ratings and specifications

■ Standards approved

UL508	File No. E44592
CSA C22.2 No.14	File No. LR20479

■ Specifications (Indoor use)

Item	Illuminated pushbutton switch	Illuminated lever switch Illuminated rocker switch	Pilot light
Rated insulation voltage	250V AC/DC		
Ambient temperature (no condensation or no icing)	-5 to +40°C		
Humidity	45 to 85%RH (at -5 to +40°C), no condensation or no icing		
Durability (operations)	Mechanical	1NO+1NC, 2NO+2NC Momentary action: 1 million Alternate action: 250,000 3NO+3NC*, 4NO+4NC*: 100,000	100,000
	Electrical	100,000 (220V AC 0.7A)	
Dielectric strength	2000V AC, 1 minute (Between lamp and contact terminals: 1500V AC, 1 minute)		
Pollution degree	3		
Vibration	Resonance: 10 to 55Hz, double amplitude 0.1mm Constant: 16.7Hz, double amplitude 3mm		
Shock	Malfunction durability: 100m/s ² Mechanical durability: 500m/s ²		Mechanical durability: 500m/s ²
Insulation resistance	100MΩ or more (500V DC megger)		
Degree of protection	IP40		

Notes: * AG23 type only.

■ Contact ratings

• UL/CSA standards

Rated thermal current	Rated operational voltage	Maximum current	
		AC (Res. load)	DC (Res. load)
5A	24V	—	1.0A
	125V	—	0.2A
	250V	5.0A	—

• JIS standards

Rated thermal current	Rated operational voltage	Rated operational current				
		AC 15 (Ind. load)	AC 13 (Ind. load)	AC 12 (Res. load)	DC 13* (Ind. load)	DC 12 (Res. load)
5A	24V	—	—	—	0.7A	1.0A
	110V	0.3A	1.0A	1.5A	—	—
	220V	0.3A	0.7A	1.0A	0.15A	0.2A

Notes: *T.C. (T_{0.632})= 7ms

■ Contact reliability

FUJI has confirmed that the unit can be used in 1mA circuit conditions at 5V AC or DC. The operable range may vary depending on the ambient conditions and type of load.











Illuminated Switches/Pilot Lights
AG22 and AG23
Ratings and specifications

■ **Power consumption**
 • AG22, 23











Operating Voltage (V)	LED Lamp [w/split]						Incandescent lamp [W/1-lamp]					
	Illuminated pushbutton switch, pilot light				Lever switch, rocker switch							
	0-split	2-split		3-split		4-split		1-lamp	2-lamp			
5	0.4	0.2	0.2	0.1	0.1	0.1	0.1	0.21	0.21	0.21	0.21	0.45
6	0.48	0.24	0.24	0.12	0.12	0.12	0.12	0.25	0.25	0.25	0.25	-
12	0.48	0.24	0.24	0.24	0.24	0.24	0.24	0.34	0.34	0.34	0.34	0.55
24	0.36	0.36	0.36	0.36	0.36	0.36	0.36	0.34	0.34	0.34	0.34	0.55

Illuminated pushbutton Switches/Pilot Lights AG22 and AG23











■ Illuminated pushbutton switches (Incandescent lamp) Momentary action

Description	Color insert split	1NO+1NC *1 *2 *3	2NO+2NC *1 *2 *3
		Type	Type
 SM-346 AG22-L	A 	AG22-LAX1■(-)□	AG22-LAX2■(-)□
	B 	AG22-LBX1■(-)□	AG22-LBX2■(-)□
 SM-293 AG23-L	A 	AG23-LAX1■(-)□	AG23-LAX2■(-)□
	B 	AG23-LBX1■(-)□	AG23-LBX2■(-)□
	C 	AG23-LCX1■(-)□	AG23-LCX2■(-)□
	D 	AG23-LDX1■(-)□	AG23-LDX2■(-)□
	E 	AG23-LEX1■(-)□	AG23-LEX2■(-)□
	F 	AG23-LFX1■(-)□	AG23-LFX2■(-)□

Alternate action

Description	Color insert split	1NO+1NC *1 *2 *3	2NO+2NC *1 *2 *3
		Type	Type
 SM-345 AG22-L5	A 	AG22-L5AX1■(-)□	AG22-L5AX2■(-)□
	B 	AG22-L5BX1■(-)□	AG22-L5BX2■(-)□
 SM-295 AG23-L5	A 	AG23-L5AX1■(-)□	AG23-L5AX2■(-)□
	B 	AG23-L5BX1■(-)□	AG23-L5BX2■(-)□
	C 	AG23-L5CX1■(-)□	AG23-L5CX2■(-)□
	D 	AG23-L5DX1■(-)□	AG23-L5DX2■(-)□
	E 	AG23-L5EX1■(-)□	AG23-L5EX2■(-)□
	F 	AG23-L5FX1■(-)□	AG23-L5FX2■(-)□

■ Pilot lights (Incandescent lamp)

Description	Color insert split	1NO+1NC *1 *2 *3
		Type
 SM-346 AG22-Z	A 	AG22-ZAX■(-)□
	B 	AG22-ZBX■(-)□
 SM-294 AG23-Z	A 	AG23-ZAX■(-)□
	B 	AG23-ZBX■(-)□
	C 	AG23-ZCX■(-)□
	D 	AG23-ZDX■(-)□
	E 	AG23-ZEX■(-)□
	F 	AG23-ZFX■(-)□

■ Dimensions, mm

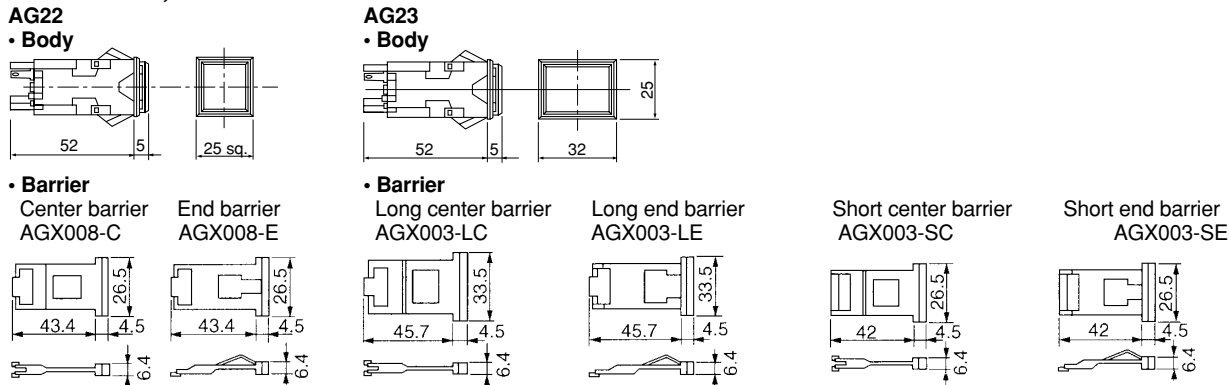

Notes:

*1
Replace the ■ mark by the lamp voltage code

A: 5V AC/DC
B: 12V AC/DC
C: 15V AC/DC
E: 24V AC/DC







*2
Replace the () mark by the mounting angle code
Blank: Horizontal mounting
T: Vertical mounting

*3
Replace the □ mark by the flange color code
Blank: Gray (Standard)
B: Black

For AG23 type illuminated pushbutton switch,
3NO+3NC and 4NO+4NC are also available.

■ Color insert kits

Illuminated pushbutton switches and pilot lights with an incandescent lamp comprise the following number of green, red, white, orange and blue inserts, legend plates and light baffle plates.

Color insert split	Color insert			Light baffle			Legend plate
	Full	Half	Quarter	Half	Quarter		
A 	5	-	-	-	-	-	1
B 	-	5	-	1	-	-	1
C 	-	-	5	-	1	-	1
D 	-	5	-	5	1	-	1
E 	-	-	5	5	-	1	1
F 	-	-	-	10	1	-	2

■ Wiring diagrams

AG22 (2NO+2NC)

• Terminal arrangement

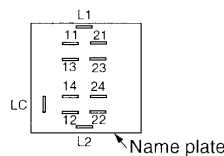

AG23 (4NO+4NC)



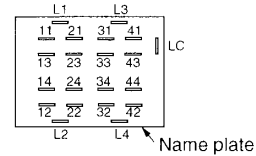







• Terminal arrangement





View from terminal side

■ Illuminated pushbutton switches (LED lamp)

• Indicators











Description	Color insert split	Type*1 *2
 AG22-L	A 	AG22-LA ■-△
	B 	AG22-LB ■-△△
 AG23-L	A 	AG23-LA ■-△
	B 	AG23-LB ■-△△
	C 	AG23-LC ■-△△
	D 	AG23-LD ■-△△△
	E 	AG23-LE ■-△△△
	F 	AG23-LF ■-△△△△

• Contact unit

Description	Contact	Momentary action Type*3*4	Alternate action Type*3*4
 AG22-L	1NO+1NC	AG22-L1 -()□	AG22-L51 -()□
	2NO+2NC	AG22-L2 -()□	AG22-L52 -()□
 AG23-L	1NO+1NC	AG23-L1 -()□	AG23-L51 -()□
	2NO+2NC	AG23-L2 -()□	AG23-L52 -()□
	3NO+3NC	AG23-L3 -()□	AG23-L53 -()□
	4NO+4NC	AG23-L4 -()□	AG23-L54 -()□

■ Pilot lights (LED lamp)

• Indicators

Description	Color insert split	Type*1 *2
 AG22-Z	A 	AG22-ZA ■-△
	B 	AG22-ZB ■-△△
 AG23-Z	A 	AG23-ZA ■-△
	B 	AG23-ZB ■-△△
	C 	AG23-ZC ■-△△
	D 	AG23-ZD ■-△△△
	E 	AG23-ZE ■-△△△
	F 	AG23-ZF ■-△△△△

■ Wiring diagrams (Lamp circuit)

AG22

• Incandescent lamp

Full face

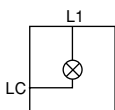

2-way

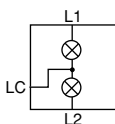

View from terminal side

• LED lamp

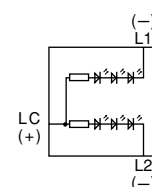
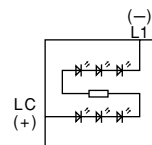

AG23

• Incandescent lamp

Full face

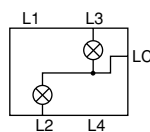

2, 3, 4 - way split

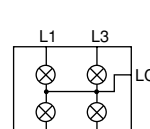

• LED lamp (24V)

Full face

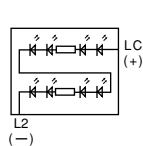

2-way Horizontal split

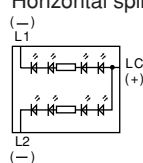

2 - way Vertical split

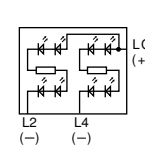

3 - way split (Half at top)

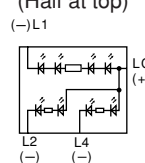

3 - way split (Half at left)

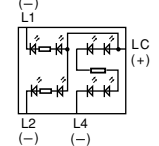

4 - way split

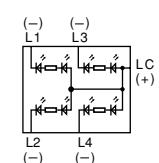

Notes:

*1 Replace the ■ mark by the lamp voltage code.

A3: 6V DC

B3: 12V DC

E3: 24V DC

*2 Replace the △ mark by color code depending on the type of split patterns.

G: Green, R: Red, W: White, O: Orange, Y: Yellow
(For color insert sequence, see page 04CD/1/4)

*3 Replace the () mark by the mounting code.

Blank: Horizontal mounting

T: Vertical mounting

*4 Replace the □ mark by the flange color code.

Blank: Gray, B: Blank

■ Ordering information

Example

• Indicator

AG23 series AG23

Illuminated pushbutton L

4-way split color insert F

LED lamp 24V DC (Anode common) E3

Color sequence 1: Green 2: Red GRWO

4: Orange 3: White

Type number AG23-LFE3-GRWO

• Contact unit

Momentary action L



Contact block 2NO+2NC 2

Horizontal mounting Blank

Color of flange Gray Blank

Type number AG23-L2

• Sockets



Description	Type code*3*4
 AG22-Z6	AG22-Z6 -()□
 AG23-Z6	AG23-Z6 -()□

Illuminated lever Switches AG23

■ Illuminated lever switches/Incandescent lamps

Description	Contact block	No. of lamp	Operation	2-position Type*	3-position Type*
 SP-1108	1NO+1NC	1 2	Maintained	AG23-HL2Δ1■-1()□/▲ AG23-HL2Δ1■-2()□/▲	— —
	2NO+2NC	1 2		AG23-HL2Δ2■-1()□/▲ AG23-HL2Δ2■-2()□/▲	AG23-HL3Δ2■-1()□/▲ AG23-HL3Δ2■-2()□/▲
	3NO+3NC	1 2		AG23-HL2Δ3■-1()□/▲ AG23-HL2Δ3■-2()□/▲	AG23-HL3Δ3■-1()□/▲ AG23-HL3Δ3■-2()□/▲
	1NO+1NC	1 2	Spring return	AG23-HL0Δ1■-1()□/▲ AG23-HL0Δ1■-2()□/▲	— —
	2NO+2NC	1 2		AG23-HL0Δ2■-1()□/▲ AG23-HL0Δ2■-2()□/▲	AG23-HL1Δ2■-1()□/▲ AG23-HL1Δ2■-2()□/▲
	3NO+3NC	1 2		AG23-HL0Δ3■-1()□/▲ AG23-HL0Δ3■-2()□/▲	AG23-HL1Δ3■-1()□/▲ AG23-HL1Δ3■-2()□/▲
2NO+2NC	1 2	Spring/ manual return	—	AG23-HL6Δ2■-1()□/▲ AG23-HL6Δ2■-2()□/▲	
3NO+3NC	1 2		—	AG23-HL6Δ3■-1()□/▲ AG23-HL6Δ3■-2()□/▲	

■ Illuminated lever switches/LED lamps

Description	Contact block	No. of lamp	Operation	2-position Type*	3-position Type*
 KK04-047A	1NO+1NC	1 2	Maintained	AG23-HL2Δ1■2-1()□/▲ AG23-HL2Δ1■2-2()□/▲	— —
	2NO+2NC	1 2		AG23-HL2Δ2■2-1()□/▲ AG23-HL2Δ2■2-2()□/▲	AG23-HL3Δ2■2-1()□/▲ AG23-HL3Δ2■2-2()□/▲
	3NO+3NC	1 2		AG23-HL2Δ3■2-1()□/▲ AG23-HL2Δ3■2-2()□/▲	AG23-HL3Δ3■2-1()□/▲ AG23-HL3Δ3■2-2()□/▲
	1NO+1NC	1 2	Spring return	AG23-HL0Δ1■2-1()□/▲ AG23-HL0Δ1■2-2()□/▲	— —
	2NO+2NC	1 2		AG23-HL0Δ2■2-1()□/▲ AG23-HL0Δ2■2-2()□/▲	AG23-HL1Δ2■2-1()□/▲ AG23-HL1Δ2■2-2()□/▲
	3NO+3NC	1 2		AG23-HL0Δ3■2-1()□/▲ AG23-HL0Δ3■2-2()□/▲	AG23-HL1Δ3■2-1()□/▲ AG23-HL1Δ3■2-2()□/▲
	2NO+2NC	1 2	Spring/ manual return	—	AG23-HL6Δ2■2-1()□/▲ AG23-HL6Δ2■2-2()□/▲
3NO+3NC	1 2	—		AG23-HL6Δ3■2-1()□/▲ AG23-HL6Δ3■2-2()□/▲	
 SP-1108	1NO+1NC	1 2	Maintained	AG23-HL2Δ1■3-1()□/▲ AG23-HL2Δ1■3-2()□/▲	— —
	2NO+2NC	1 2		AG23-HL2Δ2■3-1()□/▲ AG23-HL2Δ2■3-2()□/▲	AG23-HL3Δ2■3-1()□/▲ AG23-HL3Δ2■3-2()□/▲
	3NO+3NC	1 2		AG23-HL2Δ3■3-1()□/▲ AG23-HL2Δ3■3-2()□/▲	AG23-HL3Δ3■3-1()□/▲ AG23-HL3Δ3■3-2()□/▲
	1NO+1NC	1 2	Spring return	AG23-HL0Δ1■3-1()□/▲ AG23-HL0Δ1■3-2()□/▲	— —
	2NO+2NC	1 2		AG23-HL0Δ2■3-1()□/▲ AG23-HL0Δ2■3-2()□/▲	AG23-HL1Δ2■3-1()□/▲ AG23-HL1Δ2■3-2()□/▲
	3NO+3NC	1 2		AG23-HL0Δ3■3-1()□/▲ AG23-HL0Δ3■3-2()□/▲	AG23-HL1Δ3■3-1()□/▲ AG23-HL1Δ3■3-2()□/▲
	2NO+2NC	1 2	Spring/ manual return	—	AG23-HL6Δ2■3-1()□/▲ AG23-HL6Δ2■3-2()□/▲
3NO+3NC	1 2	—		AG23-HL6Δ3■3-1()□/▲ AG23-HL6Δ3■3-2()□/▲	



- * • Replace the Δ mark by the lamp color codes.
 G: Green R: Red W: White Y: Yellow O: Orange
 S: Blue (Incandescent Lamp only)
 • Replace the ■ mark by the lamp voltage codes
 Incandescent A: 5V AC/DC B: 12V AC/DC C: 15V AC/DC E: 24V AC/DC
 LED AA: 5V DC A: 6V DC B: 12V DC E: 24V DC

- Replace the () mark by the mounting angle code.
 Blank: Horizontal mounting
 T: Vertical mounting
 • Replace the □ mark by the flange color codes.
 Blank: Gray (Standard) B: Black
 • Replace the ▲ mark by the lever color codes.
 Blank: Black (Standard) H: Gray R: Red

■ Illuminated rocker switches/Incandescent lamps

Description	Contact block	No. of lamp	Operation	2-position Type*	3-position Type*
 SP-1107	1NO+1NC	1 2	Maintained	AG23-RL2△1■-1()□ AG23-RL2△1■-2()□	— —
	2NO+2NC	1 2		AG23-RL2△2■-1()□ AG23-RL2△2■-2()□	AG23-RL3△2■-1()□ AG23-RL3△2■-2()□
	3NO+3NC	1 2		AG23-RL2△3■-1()□ AG23-RL2△3■-2()□	AG23-RL3△3■-1()□ AG23-RL3△3■-2()□
	1NO+1NC	1 2	Spring return	AG23-RL0△1■-1()□ AG23-RL0△1■-2()□	— —
	2NO+2NC	1 2		AG23-RL0△2■-1()□ AG23-RL0△2■-2()□	AG23-RL1△2■-1()□ AG23-RL1△2■-2()□
	3NO+3NC	1 2		AG23-RL0△3■-1()□ AG23-RL0△3■-2()□	AG23-RL1△3■-1()□ AG23-RL1△3■-2()□
	2NO+2NC	1 2	Spring/ manual return	—	AG23-RL6△2■-1()□ AG23-RL6△2■-2()□
	3NO+3NC	1 2		—	AG23-RL6△3■-1()□ AG23-RL6△3■-2()□

■ Illuminated rocker switches/LED lamps

Description	Contact block	No. of lamp	Operation	2-position Type*	3-position Type*	
 KK04-048A	1NO+1NC	1 2	Maintained	AG23-RL2△1■2-1()□ AG23-RL2△1■2-2()□	— —	
	2NO+2NC	1 2		AG23-RL2△2■2-1()□ AG23-RL2△2■2-2()□	AG23-RL3△2■2-1()□ AG23-RL3△2■2-2()□	
	3NO+3NC	1 2		AG23-RL2△3■2-1()□ AG23-RL2△3■2-2()□	AG23-RL3△3■2-1()□ AG23-RL3△3■2-2()□	
	1NO+1NC	1 2	Spring return	AG23-RL0△1■2-1()□ AG23-RL0△1■2-2()□	— —	
	2NO+2NC	1 2		AG23-RL0△2■2-1()□ AG23-RL0△2■2-2()□	AG23-RL1△2■2-1()□ AG23-RL1△2■2-2()□	
	3NO+3NC	1 2		AG23-RL0△3■2-1()□ AG23-RL0△3■2-2()□	AG23-RL1△3■2-1()□ AG23-RL1△3■2-2()□	
	2NO+2NC	1 2	Spring/ manual return	—	AG23-RL6△2■2-1()□ AG23-RL6△2■2-2()□	
	3NO+3NC	1 2		—	AG23-RL6△3■2-1()□ AG23-RL6△3■2-2()□	
	 SP-1107	1NO+1NC	1 2	Maintained	AG23-RL2△1■3-1()□ AG23-RL2△1■3-2()□	— —
		2NO+2NC	1 2		AG23-RL2△2■3-1()□ AG23-RL2△2■3-2()□	AG23-RL3△2■3-1()□ AG23-RL3△2■3-2()□
3NO+3NC		1 2	AG23-RL2△3■3-1()□ AG23-RL2△3■3-2()□		AG23-RL3△3■3-1()□ AG23-RL3△3■3-2()□	
1NO+1NC		1 2	Spring return	AG23-RL0△1■3-1()□ AG23-RL0△1■3-2()□	— —	
2NO+2NC		1 2		AG23-RL0△2■3-1()□ AG23-RL0△2■3-2()□	AG23-RL1△2■3-1()□ AG23-RL1△2■3-2()□	
3NO+3NC		1 2		AG23-RL0△3■3-1()□ AG23-RL0△3■3-2()□	AG23-RL1△3■3-1()□ AG23-RL1△3■3-2()□	
2NO+2NC		1 2	Spring/ manual return	—	AG23-RL6△2■3-1()□ AG23-RL6△2■3-2()□	
3NO+3NC		1 2		—	AG23-RL6△3■3-1()□ AG23-RL6△3■3-2()□	

- * Replace the △ mark by the lamp color codes
G: Green R: Red W: White Y: Yellow O: Orange
S: Blue (Incandescent Lamp only)
- Replace the ■ mark by the lamp voltage codes
Incandescent A: 5V AC/DC B: 12V AC/DC C: 15V AC/DC E: 24V AC/DC
LED AA: 5V DC A: 6V DC B: 12V DC E: 24V DC

- Replace the () mark by the mounting angle code
Blank: Horizontal mounting
T: Vertical mounting
- Replace the □ mark by the flange color codes
Blank: Gray (Standard) B: Black

Illuminated lever Switches/Illuminated rocker Switches

AG23

Dimensions

■ Dimensions, mm

Lever switches

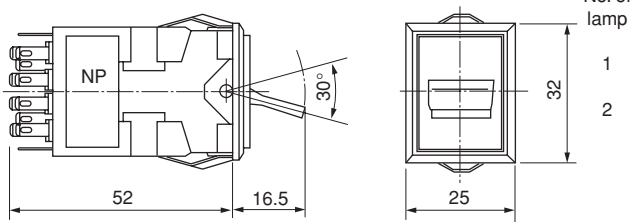

Rocker switches

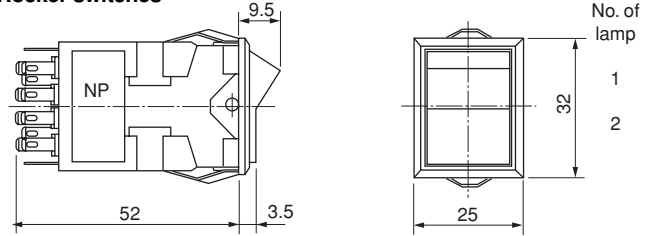

■ Wiring diagrams (AG23 4NO+4NC)

• Terminal arrangement

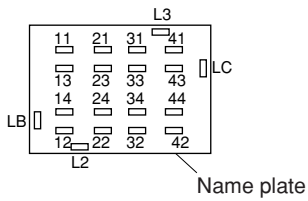

■ Wiring diagrams (Lamp circuit)

• Incandescent lamp

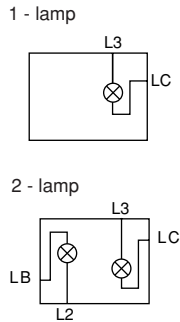

• LED lamp

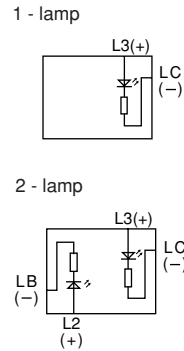

■ Contact arrangement

Operator position	1NO+1NC	2NO+2NC	3NO+3NC	4NO+4NC
2-position	1			
	1	41 1 2 42	11 1 2 12 41 1 2 42	11 1 2 12 21 1 2 22 31 1 2 32 41 1 2 42
	2	43 3 4 44	13 1 2 14 43 1 2 44	13 1 2 14 23 1 2 24 33 1 2 34 43 1 2 44
	2			
3-position	1			
	1			
	2	-	11 1 2 3 12 41 1 2 3 42	11 1 2 3 12 21 1 2 3 22 31 1 2 3 32 41 1 2 3 42
	3		13 1 2 3 14 43 1 2 3 44	13 1 2 3 14 23 1 2 3 24 33 1 2 3 34 43 1 2 3 44

Note: The operator position shown is where the nameplate-stuck-surface is positioned toward you.

Notes on use

■ **Mounting the Switches (Pilot lights)**

Mounting the switches by inserting them into place in the front of the mounting panel.
 The switches will be held in position by the mounting springs.

■ **Panel cutting**

• **AG 22**

Description		Mounting design	Panel cutting	Remarks
Flange mounting	Individual mounting (Horizontal)			Panel cutting space between rows of units
	Manifold mounting (Horizontal)			
Barrier mounting	Individual mounting (Horizontal)			Panel cutting space between rows of units Dotted line indicates the position of each mounting barrier
	Manifold mounting (Horizontal)			

Notes • n: Number of mounted unit Max 10 Panel thickness: 1 to 5 mm (with dust covers: 1 to 4 mm)
 • For vertical mounting, contact FUJI
 • The dimensions in parentheses are for tandem mounting of switches with dust covers.

• **AG 23**

Description		Mounting design	Panel cutting	Remarks
Flange mounting	Individual mounting (Horizontal)			Panel cutting space between rows of units
	Manifold mounting (Horizontal)			
	Individual mounting (Vertical)			
	Manifold mounting (Vertical)			
Barrier mounting	Individual mounting (Horizontal)			Panel cutting space between rows of units Dotted line indicates the position of each mounting barrier
	Manifold mounting (Horizontal)			
	Individual mounting (Vertical)			
	Manifold mounting (Vertical)			

Notes • n: Number of mounted unit Max 10 Panel thickness: 1 to 5 mm (with dust covers: 1 to 4 mm)
 • The dimensions in parentheses are for tandem mounting of switches with dust covers.

Illuminated Switches/Pilot Lights

AG22 and AG23

Notes on use

■ Installing or removing switches

- To install switches in the standard mounting or barrier-isolated single-unit mounting method, insert the switches one at a time from the front of the panel.
- Installing the main bodies of the switches
If the mounting panel is vertical, install the switches with their nameplates positioned at the bottom. If the mounting panel is horizontal, install the switches with their nameplates positioned on this side.
- If the mounting panel is thin (1 to 2 mm thick), make panel cutouts smaller.

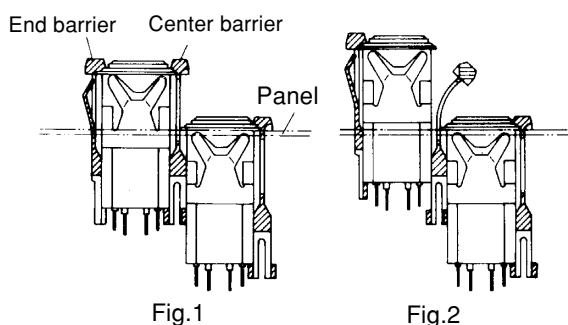

- When the barrier-isolated tandem-mounting method is employed, you can sequentially install switches one by one. For the final one, place a part of the center barrier in the mounting hole beforehand, and then insert the switch into the mounting hole so that the end barrier is in close contact with the main body of the switch (procedure: Fig.2 to Fig.1)
- To remove a switch which has been installed in the standard mounting or barrier-isolated single-unit mounting method, push out the switch by pushing it from the back of the panel while holding the panel by pushing it inward.
- To remove switches which have been installed in the barrier-isolated tandem-mounting method, proceed as follows: disengage the rear of the barrier on both sides of the switch to be removed so that the barriers are attached to the switch and, push the switch outward from the back of the panel while holding the front of the mounting panel firm, and take out the switch by opening the barriers by bending them to both sides on the front side of the panel (procedure: Fig.1 to Fig.2)

■ Operating voltage and rated voltage of incandescent lamps

Rated voltage	Operating voltage
6V	4 to 5V
14V	10 to 12V
18V	12 to 15V
28V (Standard)	20 to 24V

Incandescent lamps should be operated at the operating voltages if a lamp service life of 5,000 to 10,000 hours are needed. The ambient temperature must not exceed 30°C if the lamp is used at the rated voltage continuously.

■ Removing the lighting unit...AG23 (Oblong)

To remove the lighting unit, refer to the illustrations given in the below. (Especially when removing the unit installed on a panel)

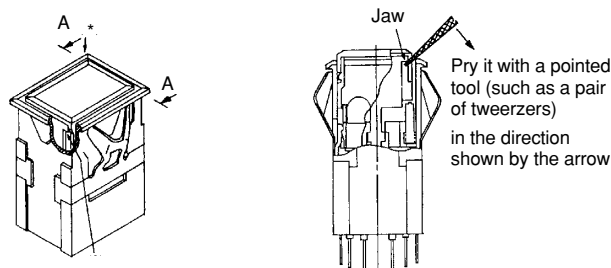

Remarks *The unit has two jaws at lower left as indicated with the asterisks
Cross section A-A (main components only)

■ Lamp replacement (For illuminated pushbutton and pilot lights)

To replace a lamp, pull out the entire lighting unit and replace the lamp from the back of the lamp holder. Install the lighting unit so that it conforms with the contact end inside the switch main-body. The inserting force must not be greater than 60N.

■ Installing the lighting section

Install the lighting unit aligning the "TOP" display on the lighting unit and switch main-body as shown in the below.

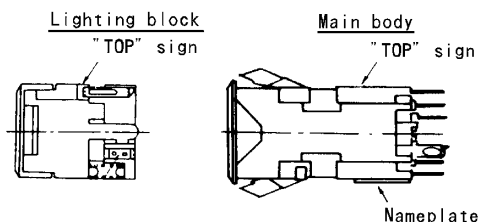

Do not push the internal mechanism of the switch main body while the lamp unit has been removed. Deformation of contact piece for the lamp may result in poor lighting or malfunction.

■ Replacing the lamp (Lever type or rocker type)

To remove the lamp, remove the lens by using a screwdriver or other pointed tool (see the illustrations in the below) and then pull out the lamp by using a lamp remover (Type AHX672). To install the lamp, insert it with your fingers and then put back the lens.

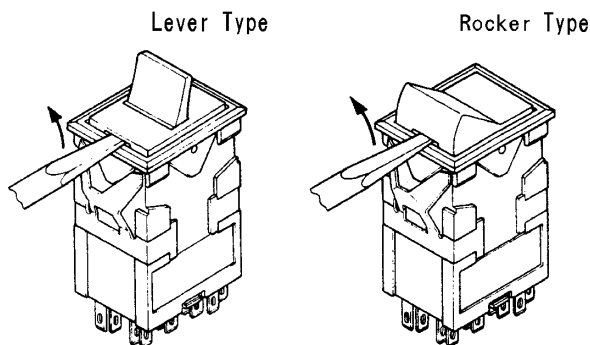

Illuminated Switches/Pilot Lights AG22 and AG23 Notes on use

■ Removeing or installing the lens

To remove the lens, slide it horizontally. To install the lens, align it with the lamp house and insert it from the top.

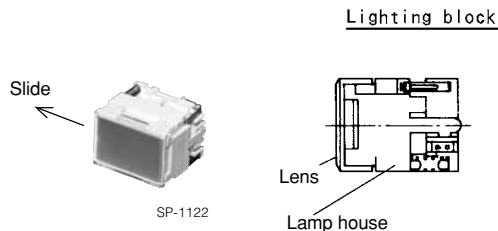

■ Installing the color plate and nameplate

Install the color plate and Nameplate in the lens section with their grained surfaces directed inward.

■ Removeing or installing the nameplate (Lever type)

To remove the nameplate from the lens, press the studs of the lens against a flat plane so that the lens is widened slightly, and insert a screwdriver or other pointed tool into the groove of the nameplate. (See the illustration in the below.)

To install the nameplate into the cover, put the end of thenameplate in the cover and then press the nameplate into the cover by pinching them with your fingers. (See the illustration in the below.)

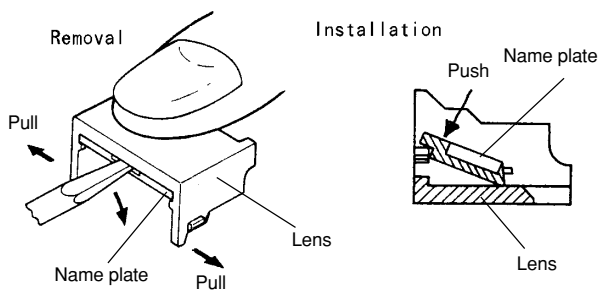

■ Contact block

To replace a contact block, use removing tool AGX012. If excessive force is applied when attempting to open the support legs for the contact block holder, deformation or damage may occur.

■ Contacts configuration modifications

Note that there are certain restrictions on contact configuration modifications.

No modifications other than those below are available. Although it is not impossible to modify a switch with 3a3b or 4a4b into that with 2a2b, do not attempt this modification because the layout of the contacts of the former differs from that of the latter.

Caution: never remove any of the contact units or dummy units which are located at both ends. If you do, the main units of the switches may be damaged, may become unable to be installed, or other troubles may result.

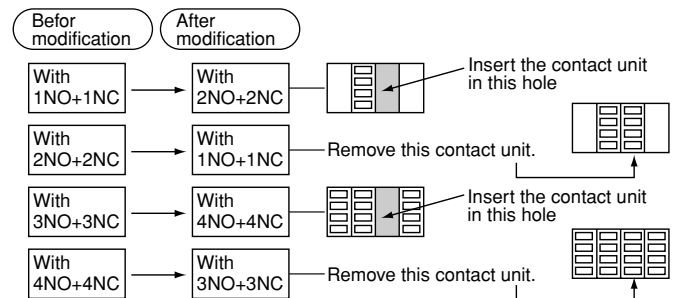

■ Wiring connections

- Use a soldering iron with a wattage of not more than 30W and a tip length of more than 20mm. Use a rosin-core solder. With a 30W iron complete soldering within 5 seconds, or 10 seconds with a 20W iron. Do not apply external force to the terminals. Do not deform the terminals. Because lead-free solder's melting point is slightly high, soldering work may be difficult. Use a soldering iron whose tip is rather large or whose calorie is rather high.
- Wires that can be connected
 - Two solid wires with a maximum diameter of 0.8mm (solder)
 - One stranded wire with a maximum area of 0.75mm² (solder)
- Using contact blocks
 - When using NO and NC contacts in the same contact block, avoid connection that involves opposite polarity or wiring from different types of power supply.
- For wiring to adjacent terminals, use insulated tubing to prevent short-circuit and to assure isolation. For solder terminals, be careful when connecting thick wires. Do not use too much solder.

■ Installing lamps in close order

When continuously lighting pilot lights or pressing illuminated pushbuttons installed in close order, care must be taken that the ambient temperature does not exceed the rated value.

■ Alternate types

AG23-L5

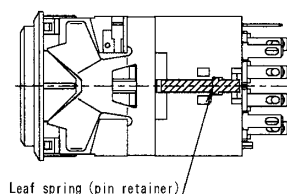

AG22-L5

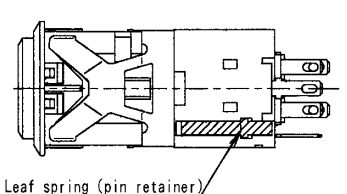

Do not open/close the switch with its leaf spring held pressed. If you do, the alternate mechanism can be damaged.

Illuminated Switches/Pilot Lights

AG22 and AG23

Notes on use

■ Dismounting the switch (Main body)

- ① To remove the main body of a rectangular command switch installed on a panel, bend the mounting springs and push them outside of the main body. If it is densely packed with other devices, use the removing tool (Type AGX013) for ease of removal.
- ② For how to use the removing tool, see the illustration in the below. Insert the tool from back of the switch (main-body) and then push out the switch.

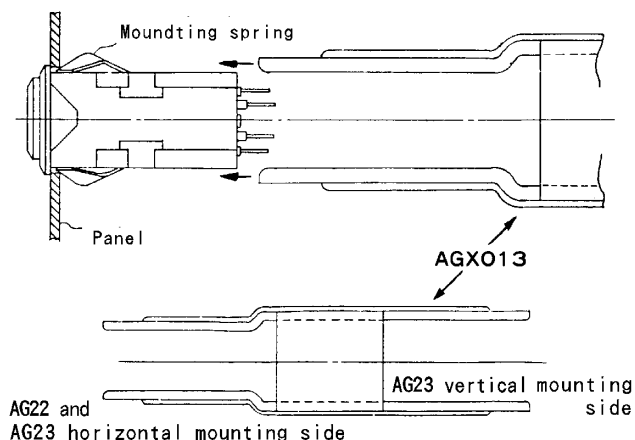

■ Operation

Do not use a hitting or bouncing action to operate the button, or the switch may break. Always operate the switch by hand.





■ Storage and operating environment





Observe the operating ambient temperature and humidity specifications indicated in the catalog or other related material. Do not use the switches in a location where they are exposed to being splashed with oil or water. The location must not be dusty.

- If it is inevitable that the installed switches will be exposed to dust or metallic particles caused by factory installation work or other tasks, cover the switches with suitable sheets to protect them.
- If using the switches in a dusty atmosphere cannot be avoided protect the switches with dust covers.

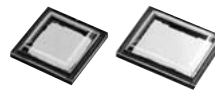
Illuminated Switches/Pilot Lights AG22 and AG23 Accessories

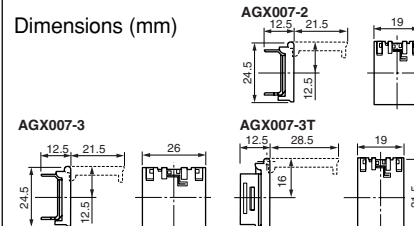
■ Accessories

Description	Type																																													
Barrier  <small>SM-337</small>  <small>SM-313</small>	<table border="1"> <thead> <tr> <th></th> <th>Color</th> <th>Type</th> </tr> </thead> <tbody> <tr> <td>For AG22</td> <td></td> <td></td> </tr> <tr> <td>Center</td> <td>Black</td> <td>AGX008-CB</td> </tr> <tr> <td>-barrier</td> <td>Gray</td> <td>AGX008-CH</td> </tr> <tr> <td>End-barrier</td> <td>Black</td> <td>AGX008-EB</td> </tr> <tr> <td></td> <td>Gray</td> <td>AGX008-EH</td> </tr> <tr> <td>For AG23</td> <td></td> <td></td> </tr> <tr> <td>Long center</td> <td>Black</td> <td>AGX003-LCB</td> </tr> <tr> <td>-barrier</td> <td>Gray</td> <td>AGX003-LCH</td> </tr> <tr> <td>Long end</td> <td>Black</td> <td>AGX003-LEB</td> </tr> <tr> <td>-barrier</td> <td>Gray</td> <td>AGX003-LEH</td> </tr> <tr> <td>Short center</td> <td>Black</td> <td>AGX003-SCB</td> </tr> <tr> <td>-barrier</td> <td>Gray</td> <td>AGX003-SCH</td> </tr> <tr> <td>Short end</td> <td>Black</td> <td>AGX003-SEB</td> </tr> <tr> <td>-barrier</td> <td>Gray</td> <td>AGX003-SEH</td> </tr> </tbody> </table>		Color	Type	For AG22			Center	Black	AGX008-CB	-barrier	Gray	AGX008-CH	End-barrier	Black	AGX008-EB		Gray	AGX008-EH	For AG23			Long center	Black	AGX003-LCB	-barrier	Gray	AGX003-LCH	Long end	Black	AGX003-LEB	-barrier	Gray	AGX003-LEH	Short center	Black	AGX003-SCB	-barrier	Gray	AGX003-SCH	Short end	Black	AGX003-SEB	-barrier	Gray	AGX003-SEH
	Color	Type																																												
For AG22																																														
Center	Black	AGX008-CB																																												
-barrier	Gray	AGX008-CH																																												
End-barrier	Black	AGX008-EB																																												
	Gray	AGX008-EH																																												
For AG23																																														
Long center	Black	AGX003-LCB																																												
-barrier	Gray	AGX003-LCH																																												
Long end	Black	AGX003-LEB																																												
-barrier	Gray	AGX003-LEH																																												
Short center	Black	AGX003-SCB																																												
-barrier	Gray	AGX003-SCH																																												
Short end	Black	AGX003-SEB																																												
-barrier	Gray	AGX003-SEH																																												
Bezel  <small>SM-354</small>	<table border="1"> <thead> <tr> <th></th> <th>Color</th> <th>Type</th> </tr> </thead> <tbody> <tr> <td>For AG22</td> <td>Black</td> <td>AGX010-2B</td> </tr> <tr> <td></td> <td>Gray</td> <td>AGX010-2H</td> </tr> <tr> <td>For AG23</td> <td>Black</td> <td>AGX010-3B</td> </tr> <tr> <td></td> <td>Gray</td> <td>AGX010-3H</td> </tr> </tbody> </table>		Color	Type	For AG22	Black	AGX010-2B		Gray	AGX010-2H	For AG23	Black	AGX010-3B		Gray	AGX010-3H																														
	Color	Type																																												
For AG22	Black	AGX010-2B																																												
	Gray	AGX010-2H																																												
For AG23	Black	AGX010-3B																																												
	Gray	AGX010-3H																																												
Color insert kit  <p>This kit contains green, red, white, orange and blue color-inserts, legend plates and light baffle plates. See page 04CD/1/8</p>	<table border="1"> <thead> <tr> <th></th> <th>Split</th> <th>Type</th> </tr> </thead> <tbody> <tr> <td>For AG22-L, Z</td> <td>Full face</td> <td>AGX019-2A</td> </tr> <tr> <td></td> <td>2-way split</td> <td>AGX019-2B</td> </tr> <tr> <td>For AG23-L, Z</td> <td></td> <td></td> </tr> <tr> <td></td> <td>Full face</td> <td>AGX019-3A</td> </tr> <tr> <td></td> <td>2-way split</td> <td>AGX019-3B</td> </tr> <tr> <td></td> <td>3-way split</td> <td>AGX019-3D</td> </tr> <tr> <td></td> <td>4-way split</td> <td>AGX019-3E</td> </tr> <tr> <td></td> <td></td> <td>AGX019-3F</td> </tr> </tbody> </table>		Split	Type	For AG22-L, Z	Full face	AGX019-2A		2-way split	AGX019-2B	For AG23-L, Z				Full face	AGX019-3A		2-way split	AGX019-3B		3-way split	AGX019-3D		4-way split	AGX019-3E			AGX019-3F																		
	Split	Type																																												
For AG22-L, Z	Full face	AGX019-2A																																												
	2-way split	AGX019-2B																																												
For AG23-L, Z																																														
	Full face	AGX019-3A																																												
	2-way split	AGX019-3B																																												
	3-way split	AGX019-3D																																												
	4-way split	AGX019-3E																																												
		AGX019-3F																																												
Legend plate  <small>SM-355</small>	<table border="1"> <thead> <tr> <th></th> <th>Color</th> <th>Type</th> </tr> </thead> <tbody> <tr> <td>For AG22-L, Z</td> <td>Clear*</td> <td>AGX009-2C</td> </tr> <tr> <td></td> <td>White</td> <td>AGX009-2W</td> </tr> <tr> <td>For AG23-L, Z</td> <td>Clear*</td> <td>AGX009-3C</td> </tr> <tr> <td></td> <td>White</td> <td>AGX009-3W</td> </tr> </tbody> </table> <p>*:Standard Dimension (mm) • 15sq.×1 (AGX009-2) • 15×23×1 (AGX009-3)</p>		Color	Type	For AG22-L, Z	Clear*	AGX009-2C		White	AGX009-2W	For AG23-L, Z	Clear*	AGX009-3C		White	AGX009-3W																														
	Color	Type																																												
For AG22-L, Z	Clear*	AGX009-2C																																												
	White	AGX009-2W																																												
For AG23-L, Z	Clear*	AGX009-3C																																												
	White	AGX009-3W																																												
Dust-tight cover  <small>SM-1528</small>	<table border="1"> <thead> <tr> <th>Type</th> <th>Used with</th> </tr> </thead> <tbody> <tr> <td>AGX011-3</td> <td>AG23-L</td> </tr> <tr> <td>AGX011-2</td> <td>AG22-L</td> </tr> </tbody> </table>	Type	Used with	AGX011-3	AG23-L	AGX011-2	AG22-L																																							
Type	Used with																																													
AGX011-3	AG23-L																																													
AGX011-2	AG22-L																																													

Description	Type															
Protection cover  <small>SM-375</small>	<table border="1"> <thead> <tr> <th></th> <th>Type</th> </tr> </thead> <tbody> <tr> <td>For AG22-L</td> <td>AGX007-2</td> </tr> <tr> <td>For AG23-L</td> <td>AGX007-3</td> </tr> <tr> <td></td> <td>AGX007-3T</td> </tr> </tbody> </table> <p>(vertical mounting) The cover protects against accidental operation. The cover lid is returned home with a spring force.</p> <p>Dimensions (mm)</p> 		Type	For AG22-L	AGX007-2	For AG23-L	AGX007-3		AGX007-3T							
	Type															
For AG22-L	AGX007-2															
For AG23-L	AGX007-3															
	AGX007-3T															
Panel plug  <small>SM-338</small>	<table border="1"> <thead> <tr> <th></th> <th>Color</th> <th>Type</th> </tr> </thead> <tbody> <tr> <td>For AG22</td> <td>Black</td> <td>AGX006-2B</td> </tr> <tr> <td></td> <td>Gray</td> <td>AGX006-2H</td> </tr> <tr> <td>For AG23</td> <td>Black</td> <td>AGX006-3B</td> </tr> <tr> <td></td> <td>Gray</td> <td>AGX006-3H</td> </tr> </tbody> </table>		Color	Type	For AG22	Black	AGX006-2B		Gray	AGX006-2H	For AG23	Black	AGX006-3B		Gray	AGX006-3H
	Color	Type														
For AG22	Black	AGX006-2B														
	Gray	AGX006-2H														
For AG23	Black	AGX006-3B														
	Gray	AGX006-3H														
Contact block  <small>SK-1141</small>	<p>AGX001</p> <p>Soldering/Tab use</p>															
Dummy unit 	<p>AGX002</p> <p>The dummy unit installs in the part which does not use the contact unit.</p>															

Illuminated Switches/Pilot Lights

AG22 and AG23

Accessories

Description	Type			
Lens For AG23-HL  SP-124	Type		Color	Split
	Incandescent, Flat LED	Spot LED		
	AGX034-R	AGX038-R	Red	Two-way split
	AGX034-G	AGX038-G	Green	
	AGX034-W	AGX038-W	White	
	AGX034-Y	AGX038-Y	Yellow	
	AGX034-S^{*1}	—	Blue	
	AGX034-O	AGX038-O	Orange	
AGX034-B^{*2}	—	Black		
^{*1} Used with the incandescent lamp only ^{*2} Used with non illuminated side of spot LED(1-lamp types)				

Description	Type			
Lens For AG23-RL  SP-123	Type		Color	Split
	Incandescent, Flat LED	Spot LED		
	AGX032-R	—	Red	Full face
	AGX032-G	—	Green	
	AGX032-W	—	White	
	AGX032-Y	—	Yellow	
	AGX032-S^{*1}	—	Blue	
	AGX032-O	—	Orange	
	AGX033-R	AGX037-R	Red	Two-split
	AGX033-G	AGX037-G	Green	
	AGX033-W	AGX037-W	White	
	AGX033-Y	AGX037-Y	Yellow	
	AGX033-S^{*1}	—	Blue	
	AGX033-O	AGX037-O	Orange	
	AGX033-B^{*2}	—	Black	
^{*1} Used with the incandescent lamp only ^{*2} Used with non illuminated side of spot LED(1-lamp types)				

Description	Type
Legend plate For AG23-HL  SP-115	AGX036-W Dimension (mm) 8.5×16.5×2

Description	Type
Legend plate For AG23-RL  SP-116	AGX035-W Dimension (mm) 9.5×16×8.5

Description	Type
Remover  SM-334, 335	For contact unit AGX012 For body AGX013

Description	Type
Remover  SP-1142	AGX039 This tool is used to remove the indicator of illuminated pushbutton or pilot light.

Description	Type
Lamp changer For AG23-HL, RL  AF02-117	Type: AHX672 If the switch is fitted with a lamp, use this tool to remove the lamp. The tool is unnecessary when installing a lamp.

Incandescent lamp	Voltage	Type
	 SD-924	6V, 0.6W 14V, 0.7W 18V, 0.7W 28V, 0.7W

Socket AGX005	Terminal	Type	Contact arrangement	Used with
	 AF02-129	Solder/tab	AGX005-S	1a1b
Wire wrap		AGX005-W	2a2b	
PC board		AGX005-P		AG23
Solder/tab		AGX004-2S	1a1b	
Wire wrap		AGX004-2W	2a2b	
PC board		AGX004-2P		
Solder/tab	AGX004-4S	3a3b		
Wire wrap	AGX004-4W	4a4b		
PC board	AGX004-4P			

AGX004			
For wiring to wire-wrap pin terminals, select appropriate wire sizes and tool from the table below.			
Wire size	Bit	Sleeve	Number of effective wraps
0.4mm dia.	3-A	1-B	About 8
0.5mm dia.	1-A	2-B	About 6
(0.65mm dia.)	(2-A)	(2-B)	(About 6)
Use ordinary wrapping for connection. Wires of 0.65mm dia. must not be used on adjacent terminals. However, 0.65mm dia. wire can be mixed with 0.4mm and 0.5mm dia. wires.			

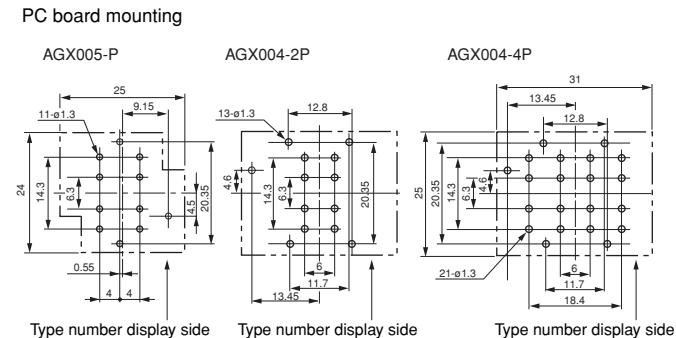
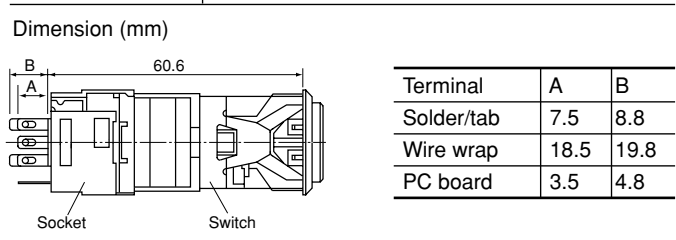

Illuminated Switches/Pilot Lights
AG22 and AG23
Mass

■ Mass, gram

Lamp type	Illuminated pushbuttons	1NO	2NO	3NO	4NO	Pilot lights		Illuminated rocker and lever switches		1NO	2NO	3NO	4NO
		+ 1NC	+ 2NC	+ 3NC	+ 4NC					+ 1NC	+ 2NC	+ 3NC	+ 4NC
Incandescent lamp	AG22-LA, L5A	21.5	22.5	–	–	AG22-ZA	18.5	AG23-RL-1	26	27	28	29	
	B, L5B	22.5	23.5	–	–	B	19.3	AG23-RL-2	28	29	30	31	
	AG23-LA, L5A	27	28	29	30	AG23-ZA	23.5	AG23-HL-1	26	27	28	29	
	B, L5B	29.2	30.2	31.2	32.2	B	25.7	AG23-HL-2	28	29	30	31	
	C, L5C	29.2	30.2	31.2	32.2	C	25.7						
	D, L5D	29.4	30.4	31.4	32.4	D	25.9						
	E, L5E	29.4	30.4	31.4	32.4	E	25.9						
F, L5F	29.5	30.5	31.5	32.5	F	26							
LED lamp	*1AG22-LA, L5A	21.8	22.8	–	–	*2AG22-ZA	19	AG23-RL-2-1	25	26	27	28	
	B, L5B	22.2	23.2	–	–	B	19	AG23-RL-2-2	27.5	28.5	29.5	30.5	
	*2AG23-LA, L5A	27.5	28.5	29.5	30.5	*2AG23-ZA	24	AG23-RL-3-1	25.5	27.2	27.5	28.5	
	B, L5B	28	29	30	31	B	24.5	AG23-RL-3-2	28	29	30	31	
	C, L5C	28	29	30	31	C	24.5	AG23-HL-2-1	25	26	27	28	
	D, L5D	28.2	29.2	30.2	31.2	D	24.7	AG23-HL-2-2	27.5	28.5	29.5	30.5	
	E, L5E	28.2	29.2	30.2	31.2	E	24.7	AG23-HL-3-1	25.5	26.5	27.5	28.5	
F, L5F	28.3	29.3	30.3	31.3	F	24.8	AG23-HL-3-2	28	29	30	31		

L5: Alternate action

*1 Combined indicators and contact unit.

*2 Combined indicators and sockets.