

## Wireless Pushbutton Switch

User's Manual  
A2W-R□□-WC1  
A2W-T□-WC1

**1**  
Operating  
Procedure

**2**  
Overview

**3**  
Survey of the Operating  
Environment and  
System Design

**4**  
Installation and Wiring  
of the Master Unit

**5**  
Registration  
in the ID Mode

**6**  
Wireless Test  
in the TEST Mode

**7**  
Run in the  
RUN Mode

**8**  
Trouble Shooting

**A**  
Appendix



## **NOTE**

All rights reserved. No part of this publication may be reproduced, stored in a retrieval system, or transmitted, in any form, or by any means, mechanical, electronic, photocopying, recording, or otherwise, without the prior written permission of OMRON.

No patent liability is assumed with respect to the use of the information contained herein. Moreover, because OMRON is constantly striving to improve its high-quality products, the information contained in this manual is subject to change without notice. Every precaution has been taken in the preparation of this manual. Nevertheless, OMRON assumes no responsibility for errors or omissions. Neither is any liability assumed for damages resulting from the use of the information contained in this publication.

## **Trademarks**

Microsoft, Windows is either registered trademarks or trademarks of Microsoft Corporation in the United States and other countries.

Other company names and product names in this document are the trademarks or registered trademarks of their respective companies.

## **Copyrights**

Microsoft product screen shots reprinted with permission from Microsoft Corporation.

# Preface

---

Thank you for purchasing an Wireless Pushbutton Switches System (A2W-R□□-WC1 Master Unit and A2W-T□-WC1 Slave button).

This manual describes how to use the Master Unit and Slave button. Read this manual thoroughly and be sure you understand it before attempting to use this products and use the products correctly according to the information provided. Keep this manual in a safe place for easy reference.

PDF version of this manual can be downloaded from the OMRON website.

(<http://www.ia.omron.com>)

# Terms and Conditions Agreement

---

## Warranty, Limitations of Liability

### Warranties

---

#### ● Exclusive Warranty

Omron's exclusive warranty is that the Products will be free from defects in materials and workmanship for a period of twelve months from the date of sale by Omron (or such other period expressed in writing by Omron). Omron disclaims all other warranties, express or implied.

#### ● Limitations

OMRON MAKES NO WARRANTY OR REPRESENTATION, EXPRESS OR IMPLIED, ABOUT NON-INFRINGEMENT, MERCHANTABILITY OR FITNESS FOR A PARTICULAR PURPOSE OF THE PRODUCTS. BUYER ACKNOWLEDGES THAT IT ALONE HAS DETERMINED THAT THE PRODUCTS WILL SUITABLY MEET THE REQUIREMENTS OF THEIR INTENDED USE.

Omron further disclaims all warranties and responsibility of any type for claims or expenses based on infringement by the Products or otherwise of any intellectual property right.

#### ● Buyer Remedy

Omron's sole obligation hereunder shall be, at Omron's election, to (i) replace (in the form originally shipped with Buyer responsible for labor charges for removal or replacement thereof) the non-complying Product, (ii) repair the non-complying Product, or (iii) repay or credit Buyer an amount equal to the purchase price of the non-complying Product; provided that in no event shall Omron be responsible for warranty, repair, indemnity or any other claims or expenses regarding the Products unless Omron's analysis confirms that the Products were properly handled, stored, installed and maintained and not subject to contamination, abuse, misuse or inappropriate modification. Return of any Products by Buyer must be approved in writing by Omron before shipment. Omron Companies shall not be liable for the suitability or unsuitability or the results from the use of Products in combination with any electrical or electronic components, circuits, system assemblies or any other materials or substances or environments. Any advice, recommendations or information given orally or in writing, are not to be construed as an amendment or addition to the above warranty.

See <http://www.omron.com/global/> or contact your Omron representative for published information.

### Limitation on Liability; Etc

---

OMRON COMPANIES SHALL NOT BE LIABLE FOR SPECIAL, INDIRECT, INCIDENTAL, OR CONSEQUENTIAL DAMAGES, LOSS OF PROFITS OR PRODUCTION OR COMMERCIAL LOSS IN ANY WAY CONNECTED WITH THE PRODUCTS, WHETHER SUCH CLAIM IS BASED IN CONTRACT, WARRANTY, NEGLIGENCE OR STRICT LIABILITY.

Further, in no event shall liability of Omron Companies exceed the individual price of the Product on which liability is asserted.

## Application Considerations

### Suitability of Use

---

Omron Companies shall not be responsible for conformity with any standards, codes or regulations which apply to the combination of the Product in the Buyer's application or use of the Product. At Buyer's request, Omron will provide applicable third party certification documents identifying ratings and limitations of use which apply to the Product. This information by itself is not sufficient for a complete determination of the suitability of the Product in combination with the end product, machine, system, or other application or use. Buyer shall be solely responsible for determining appropriateness of the particular Product with respect to Buyer's application, product or system. Buyer shall take application responsibility in all cases.

NEVER USE THE PRODUCT FOR AN APPLICATION INVOLVING SERIOUS RISK TO LIFE OR PROPERTY WITHOUT ENSURING THAT THE SYSTEM AS A WHOLE HAS BEEN DESIGNED TO ADDRESS THE RISKS, AND THAT THE OMRON PRODUCT(S) IS PROPERLY RATED AND INSTALLED FOR THE INTENDED USE WITHIN THE OVERALL EQUIPMENT OR SYSTEM.

### Programmable Products

---

Omron Companies shall not be responsible for the user's programming of a programmable Product, or any consequence thereof.

## Disclaimers

### Performance Data

---

Data presented in Omron Company websites, catalogs and other materials is provided as a guide for the user in determining suitability and does not constitute a warranty. It may represent the result of Omron's test conditions, and the user must correlate it to actual application requirements. Actual performance is subject to the Omron's Warranty and Limitations of Liability.

### Change in Specifications

---

Product specifications and accessories may be changed at any time based on improvements and other reasons. It is our practice to change part numbers when published ratings or features are changed, or when significant construction changes are made. However, some specifications of the Product may be changed without any notice. When in doubt, special part numbers may be assigned to fix or establish key specifications for your application. Please consult with your Omron's representative at any time to confirm actual specifications of purchased Product.

### Errors and Omissions

---

Information presented by Omron Companies has been checked and is believed to be accurate; however, no responsibility is assumed for clerical, typographical or proofreading errors or omissions.



# Safety Precautions

## Definition of Precautionary Information





The following notation is used in this manual to provide precautions required to ensure safe usage of a Wireless Pushbutton Switch. The safety precautions that are provided are extremely important to safety. Always read and heed the information provided in all safety precautions.

The following notation is used.

### Key to Warning Symbols

|  |  |
|--|--|
|  <b>WARNING</b> | Indicates a potentially hazardous situation which, if not avoided, could result in death or serious injury. Additionally, there may be severe property damage. |
|  <b>CAUTION</b> | Indicates a potentially hazardous situation which, if not avoided, may result in minor or moderate injury, or property damage.                                 |

## Symbols

| Symbol                   | Meaning   |  |
|--------------------------|---|--|
| <b>Caution</b>           |  | <ul style="list-style-type: none"> <li>General Caution<br/>Indicates non-specific general cautions, warnings, and dangers.</li> </ul>  |
|                          |  | <ul style="list-style-type: none"> <li>Electrical Shock Caution<br/>Indicates possibility of electric shock under specific conditions.</li> </ul>  |
| <b>Prohibition</b>       |  | <ul style="list-style-type: none"> <li>General Prohibition<br/>Indicates non-specific general prohibitions.</li> </ul>   |
|                          |  | <ul style="list-style-type: none"> <li>Disassembly Prohibition<br/>Indicates prohibitions when there is a possibility of injury, such as from electric shock, as the result of disassembly.</li> </ul> |
| <b>Mandatory Caution</b> |  | <ul style="list-style-type: none"> <li>General Caution<br/>Indicates non-specific general cautions, warnings, and dangers.</li> </ul>  |

 **WARNING**

|  |   |
|--|---|
| <p>Do not use this product without a protection circuit. Otherwise it may result in heavy injuries or damage on life or property due to malfunction.</p> <p>Dual or triple safety protection circuits, such as emergency stop, interlock, or limit circuit, must be configured by external control circuit so that the system should operate on safe side even if a failure of this product or an error due to an external factor occurred.</p>  |  |
| <p>This product is used radio waves for communications, communications may be interrupted. Depending on the surrounding environment and usage, leading to serious accidents such as severe personal injury and serious physical damage.</p> <p>Safety of the system must be maintained even in such a case. In particular, this product may be disturbed by wireless systems generating strong radio waves in the neighboring frequency band. Before starting actual operation or periodically, always perform the communications test in advance and make sure that the system operates normally before using it.</p> |   |
| <p>Never use this product for real-time control applications.</p> <p>Communications errors cause information to be delayed or missing in which may result in serious accidents.</p>  |   |
| <p>Do not use this product close to any medical equipment such as a pacemaker as it may affect operation of such medical equipment and may result in heavy injuries.</p>   |   |

**Conformance to EN Standards**

Use a DC power line less than 3 m to conform to EN standards. If a power line of 3 m or longer is required, extend the length at the Switching Power Supply's primary side (i.e., the AC power line).

# Precautions for Safe Use

---

Observe the following precautions when using this product:

## Master Unit

---

- (1) Avoid this product from coming in contact with water, oil, solvents, detergents, etc. during transportation or storage, and make sure it is not subjected to excessive vibrations and impact, or dropped down. Use a dedicated packaging box when storing this product.
- (2) Storage of this product must be within the specified environment. Allow the product to warm up to room temperature for at least 3 hours after it has been stored at  $-10^{\circ}\text{C}$  or lower.
- (3) Use the product within the specified temperature and humidity ranges.
- (4) Do not use the product under the following locations:
  - Locations subject to static electricity, excessive noise, or electric fields.
  - Locations where the product may come into contact with water, oil, or chemicals.
  - Locations where corrosive gases or flammable gases are present.
  - Locations where large amounts of dust or dirt are present.
  - Locations subject to spatters, iron chips, or fillings.
  - Locations subject to direct sunlight.
- (5) To ensure the antenna does not come off during operation, attach it right into the connector.
- (6) Do not pull or grab the antenna while carrying or handling the product.
- (7) The use of this product at other than the designated frequency is prohibited by the Radio Law. Use this product after confirming the frequency and product type according to the country of use.
- (8) Do not use the product outdoors (outside a control panel).
- (9) Tighten the mounting screws to the specified torque of 4.4 to 5.3 in lb. (0.5 to 0.6 N•m)
- (10) This product can be mounted at tight contact in the left and right direction, however do not mounted at tight contact to other heat generating products so as not to obstruct heat release.
- (11) Do not use other than the default mounting method.
- (12) Doing so may result in the product damaged or malfunction. Do not subject any product to abnormal vibration or shock and dropped it on the floor or otherwise subjected to excessive shock. To prevent damage from falls, OMRON recommends securing this product with screws when mounting it on walls, etc. Stop using this product if it is subjected to strong impacts.
- (13) When mounting the designated antenna with magnet, mount it directly on a steel plate to secure mounting strength.
- (14) When mounting the designated antenna with magnet, do not install the antenna cable together with the power line or electric cables. Also, do not forcefully pull or bend the cable, or keep any object on top.
- (15) Minor electric shock, fire, or Product failure may occasionally occur. Do not allow any pieces of metal or conductors or any clippings or cuttings resulting from installation work to enter the Product.
- (16) Do not apply voltages and to the output Terminals in excess of the maximum switching capacity.
- (17) Do not insert more than one wire into each terminal insertion hole.
- (18) Do not wire anything to the release holes.
- (19) Do not push the terminal block with a force exceeding 40 N when inserting wires or when inserting a flat-blade screwdriver in a release hole.
- (20) Do not bend a wire past its natural bending radius or pull on it with excessive force. Doing so may cause the wire disconnection.



- (21) Do not tilt or twist a flat-blade screwdriver while it is inserted into a release hole on the terminal block. The terminal block may be damaged.
- (22) Do not allow the flat-blade screwdriver to fall out while it is inserted into a release hole.
- (23) Insert a flat-blade screwdriver into the release holes at an angle. The terminal block may be damaged if you insert the screwdriver straight in.
- (24) Do not apply unnecessary strong force on various operation switches as that may damage the switches.
- (25) You will have to make the settings during installation or replacement. Make the settings correctly according to the manual, perform the communications test in advance, and make sure that the system operates normally before using it. Unintended communications may occur with the other systems during replacement. Therefore, delete the registration of all wireless push buttons once.
- (26) If vibrations or impacts are suspected, use wires with ferrules, or stranded wires.
- (27) Before starting operation, make sure there are no faults in the wires and switch settings.
- (28) This product may either hinder or be hindered by a wireless system emitting radio waves in the same frequency band. This product may be disturbed or interfere by a wireless system emitting radio waves in the same frequency band. Always perform the communications test in advance, and make sure that the system operates normally before using it.
- (29) Do not use this product near a device that may function abnormally due to the radio waves emitted by this product.
- (30) If an error display or output occurs, be sure to use this product after removing the cause.
- (31) Minor electric shock, fire, or product failure may occasionally occur. Do not disassemble, modify, fix, or touch inside of this product. Disassembly and modification are prohibited by the Radio Law in each country.
- (32) To prevent wiring materials from smoking or ignition, confirm wire ratings and use the wiring materials given in the following table.

- Recommended wires

| Recommended wires  | Wiring material |
|--------------------|-----------------|
| (mm <sup>2</sup> ) | (AWG)           |
| 0.25 to 2.5        | 24 to 14        |

- Stripping length

| Recommended Wire Type                       | Ferrules length | Recommended stripping length |                   |
|---|-----------------|------------------------------|-------------------|
|   |                 | Ferrules used                | Ferrules not used |
| 0.25 to 1.5 mm <sup>2</sup> /AWG24 to AWG16 | 8 mm            | 10 mm                        | 8 mm              |
|   | 10 mm           | 12 mm                        | 10 mm             |
| 2 to 2.5 mm <sup>2</sup> /AWG14             | 10 mm           | 12 mm                        | 10 mm             |

## Slave button

---

- (1) The switching function performance may be insufficient. Do not drop the product.
- (2) When storing this product, avoid hazardous gases (H<sub>2</sub>S, SO<sub>2</sub>, NH<sub>3</sub>, HNO<sub>3</sub>, Cl<sub>2</sub>, etc.), dust, high temperature and high humidity.
- (3) Storage temperature must be -10°C to +70°C with no condensation.
- (4) Do not use the product under the following locations:
  - Locations subject to spatters, iron chips, or fillings.
  - Locations subject to solvents such as detergent and thinner.
- (5) The product is protected from dust and water intrusion, but the operating part is not protected from fine foreign matter and water, so please do not let foreign matter or water enter. It may cause early wear, damage, etc.
- (6) The product may malfunction. Do not drop the product.
- (7) The durability of the product varies greatly depending on operating conditions. Be sure to check the operation under actual conditions before using the product, and use within the number of operations that have no problem in terms of performance.
- (8) Do not maintain or repair the product equipment user. Be sure to consult with the equipment or machinery manufacturer.
- (9) Normal operation may not be possible. Do not attempt to disassemble, repair, or modify any products.

# Precautions for Correct Use

---

Always heed these precautions to prevent faulty operation, malfunction, or adverse affect on the product's performance and functionality.

## Master Unit

---

- (1) Communications performance may be affected by its environment. Always confirm its operation before using it.
- (2) Install this product at a location where there is an unobstructed view between the wireless push buttons and the Master Unit. Note that if the wireless push buttons are operated simultaneously, it may lead to improper reception. Take measures to ensure safe operation of the system in such a case as well.
- (3) When multiple Master Units are used for a single wireless push button, the reception confirmation LED of the wireless push button lights up either in green or yellow if transmission/reception with any one Master Unit is successful. Therefore, it may not be possible to determine even if there is a Master Unit with which transmission/reception has failed only from the display status of the wireless push button. Take measures to ensure safe operation of the system in such a case as well.
- (4) Do not mount the antenna at a location surrounded by metal, such as inside the panel.
- (5) Mount the antenna while ensuring that it is not parallel with the wiring or metal plate. Also, ensure a safe distance from the wiring and metal plate.
- (6) Do not use this product at a location with an extremely high humidity, or near a television or radio, or an object from which sparks may fly out such as a motor or drill, or even near fluorescent lighting.
- (7) The Radio Law prohibits connecting an antenna other than that designated. Never change the antenna.
- (8) Do not reverse the power supply connection or connect the product to an AC power supply.
- (9) Use the correct power supply voltage.
- (10) Do not operate the Setting Switches of the Master Unit while the Wireless Pushbutton Switches System is in operation.
- (11) Always turn OFF the power before replacing the wiring or devices.
- (12) Do not handle with wet hands.
- (13) Handle this product as industrial waste during disposal.
- (14) If communications troubles occur frequently, refer to the Troubleshooting section in the User Manual for details on the actions to take.
- (15) After pressing a Slave button, wait for 100 ms before pressing the next Slave button, because the Master Unit can not receive at the same time signals of multiple Slave buttons.
- (16) If you register a Slave button to the Master Unit in an environment where another wireless push-button switch system is operating around it, it can be erroneously set. Therefore, when registering a Slave button, perform in an environment where the system of another wireless pushbutton switch is not operated.
- (17) Register Slave buttons to one Master Unit one by one. Be sure to set the other Master Units to the "RUN mode" or "TEST mode".

## Slave button

---

- (1) Check the indicators of the product in the following cases. The product was stored outside the environmental conditions, condensation has occurred in the product, the product has been dropped, or the product stored for more than one year for a long time.
- (2) Do not operate excessive force to the product.
- (3) This product is specifically designed for indoor use only. If you use the product outdoors, it may cause malfunction.
- (4) Do not use the product in liquid such as water or oil, or do not use in locations subject to exposure to water or oil. Doing so may result in water or oil entering inside the product.
- (5) Do not use the product under the following locations:
  - Places subject to intense temperature change.
  - Places subject to condensation as the result of severe changes in temperature.
- (6) Do not use the product in hazardous gases (H<sub>2</sub>S, SO<sub>2</sub>, NH<sub>3</sub>, HNO<sub>3</sub>, Cl<sub>2</sub>, etc.) or in high temperature and high humidity atmosphere. It may cause damage due to corrosion.
- (7) Do not use the Product in locations subject to vibrations.
- (8) Do not use in locations with high frequency noise. It may cause malfunction.
- (9) When installing the product, check the interference effect at the same frequency of the product.
- (10) The indicator light in the display window of the product as follows; Lit green during normal operation, lit yellow when the radio field strength is weak, lit red when communications were failed.  
When using the product, check the result of wireless communications with the display window.
- (11) Do not apply excessive force to the product.
- (12) Perform periodic inspections.

# Revision History

---

A manual revision code appears as a suffix to the catalog number on the front and back covers of the manual.

|                |                   |
|----------------|-------------------|
| <b>Man.No.</b> | <b>A265-E1-01</b> |
|----------------|-------------------|

↑  
Revision code

| Revision code | Date          | Revised content     |
|---------------|---------------|---------------------|
| 01            | December 2017 | Original production |



# Sections in this Manual

---

|          |  |          |
|----------|--|----------|
| <b>1</b> | <b>Operating Procedure</b>                                   | <b>1</b> |
| <b>2</b> | <b>Overview</b>  | <b>2</b> |
| <b>3</b> | <b>Survey of the Operating Environment and System Design</b> | <b>3</b> |
| <b>4</b> | <b>Installation and Wiring of the Master Unit</b>            | <b>4</b> |
| <b>5</b> | <b>Registration in the ID Mode</b>                           | <b>5</b> |
| <b>6</b> | <b>Wireless Test in the TEST Mode</b>                        | <b>6</b> |
| <b>7</b> | <b>Run in the RUN Mode</b>                                   | <b>7</b> |
| <b>8</b> | <b>Trouble Shooting</b>                                      | <b>8</b> |
| <b>A</b> | <b>Appendix</b>  | <b>A</b> |

# CONTENTS

---

|  |           |
|--|-----------|
| <b>Preface .....</b>                         | <b>1</b>  |
| <b>Terms and Conditions Agreement.....</b>   | <b>2</b>  |
| Warranty, Limitations of Liability .....     | 2         |
| Application Considerations .....             | 3         |
| Disclaimers .....                            | 3         |
| <b>Safety Precautions .....</b>              | <b>4</b>  |
| Definition of Precautionary Information..... | 4         |
| Symbols.....                                 | 4         |
| <b>Precautions for Safe Use .....</b>        | <b>6</b>  |
| <b>Precautions for Correct Use.....</b>      | <b>9</b>  |
| <b>Revision History .....</b>                | <b>11</b> |
| <b>Sections in this Manual .....</b>         | <b>13</b> |
| <b>CONTENTS.....</b>                         | <b>14</b> |

## Section 1      **Operating Procedure**

---

|   |            |
|---|------------|
| <b>1-1 Overall Operating Procedure.....</b> | <b>1-2</b> |
| 1-1-1 Overall Flowchart .....               | 1-2        |

## Section 2      **Overview**

---

|   |             |
|---|-------------|
| <b>2-1 Overview and Features .....</b>  | <b>2-2</b>  |
| 2-1-1 Overview .....  | 2-2         |
| 2-1-2 Features .....  | 2-3         |
| 2-1-3 Major Application Examples.....   | 2-3         |
| <b>2-2 System Configurations .....</b>  | <b>2-4</b>  |
| 2-2-1 Using the Pencil Antenna Standard Included.....                               | 2-4         |
| 2-2-2 Using Optional High-sensitivity Magnetic-base Antenna .....                   | 2-5         |
| 2-2-3 Relationship Between Slave Buttons and Master Unit.....                       | 2-6         |
| <b>2-3 List of Models .....</b>   | <b>2-8</b>  |
| 2-3-1 Master Unit and Option .....  | 2-8         |
| 2-3-2 Slave Button and Options .....  | 2-9         |
| <b>2-4 Nomenclature and Functions .....</b>   | <b>2-10</b> |
| 2-4-1 Master Unit.....  | 2-10        |
| 2-4-2 Slave Button.....   | 2-14        |
| <b>2-5 Specifications and Functions.....</b>  | <b>2-15</b> |
| 2-5-1 Wireless Specifications .....   | 2-15        |
| 2-5-2 Ratings.....  | 2-16        |
| 2-5-3 Operation Mode .....  | 2-18        |
| 2-5-4 Assignment Relationship Between Slave Button and Outputs of Master Unit ..... | 2-18        |



## Section 3 Survey of the Operating Environment and System Design

|            |   |            |
|------------|---|------------|
| <b>3-1</b> | <b>Installation and Operating Environment .....</b> | <b>3-2</b> |
| <b>3-2</b> | <b>Operation Timing Chart .....</b>                 | <b>3-5</b> |
| 3-2-1      | Operation Timing Chart .....                        | 3-5        |

## Section 4 Installation and Wiring of the Master Unit

|            |   |             |
|------------|---|-------------|
| <b>4-1</b> | <b>Dimensions .....</b>   | <b>4-2</b>  |
| 4-1-1      | Master Unit .....   | 4-2         |
| 4-1-2      | Slave button .....  | 4-4         |
| <b>4-2</b> | <b>Installing Master Units .....</b>                                  | <b>4-6</b>  |
| 4-2-1      | DIN Rail Installation .....   | 4-6         |
| 4-2-2      | Screw Mounting .....  | 4-8         |
| 4-2-3      | Using the Magnetic-base Antenna .....                                 | 4-8         |
| <b>4-3</b> | <b>Connecting Wires to Push-In Plus Terminal Block .....</b>          | <b>4-9</b>  |
| 4-3-1      | Terminal Blocks of the Master Unit .....                              | 4-9         |
| 4-3-2      | Push-In Plus Terminal Block .....                                     | 4-10        |
| 4-3-3      | Nomenclature of the Push-In Plus Terminal Block and Connections ..... | 4-10        |
| 4-3-4      | Removing Wires from the Push-In Plus Terminal Block .....             | 4-11        |
| 4-3-5      | Recommended Ferrules and Crimp Tools .....                            | 4-12        |
| <b>4-4</b> | <b>I/O Wiring of the Master Units .....</b>                           | <b>4-14</b> |
| 4-4-1      | Power Supply input Wiring .....                                       | 4-14        |
| 4-4-2      | Transistor Output Wiring .....  | 4-14        |
| 4-4-3      | Wiring of Error Output .....  | 4-15        |

## Section 5 Registration in the ID Mode

|            |   |            |
|------------|---|------------|
| <b>5-1</b> | <b>How to Register Slave Buttons to Master Unit .....</b> | <b>5-2</b> |
| 5-1-1      | Steps to Register the Slave Buttons .....                 | 5-3        |
| 5-1-2      | How to Delete Slave Buttons .....                         | 5-5        |

## Section 6 Wireless Test in the TEST Mode

|            |                            |            |
|------------|----------------------------|------------|
| <b>6-1</b> | <b>Wireless Test .....</b> | <b>6-2</b> |
|------------|----------------------------|------------|

## Section 7 Run in the RUN Mode

|            |                        |            |
|------------|------------------------|------------|
| <b>7-1</b> | <b>Operation .....</b> | <b>7-2</b> |
|------------|------------------------|------------|

## Section 8 Trouble Shooting

|            |  |            |
|------------|--|------------|
| <b>8-1</b> | <b>Trouble Situations and How to Implement Countermeasures .....</b> | <b>8-2</b> |
| 8-1-1      | Troubles at Installation or Operation .....                          | 8-2        |
| 8-1-2      | LED Indication When Trouble Occurs .....                             | 8-4        |
| <b>8-2</b> | <b>Master Unit Error .....</b>                                       | <b>8-5</b> |
| 8-2-1      | Error Status of the Master Unit .....                                | 8-5        |
| 8-2-2      | How to Reset the Error of Master Unit .....                          | 8-5        |
| 8-2-3      | How to Return Master Unit to Factory Setting .....                   | 8-6        |
| <b>8-3</b> | <b>Replacing Master Unit .....</b>                                   | <b>8-7</b> |
| 8-3-1      | How to Replace Master Unit .....                                     | 8-7        |

## Appendix

---

|     |   |     |
|-----|---|-----|
| A-1 | Slave Button Registration Management Sheet..... | A-2 |
|-----|---|-----|



# Operating Procedure

---

This section describes how to use the wireless pushbutton switches system.

---

|  |            |
|--|------------|
| <b>1-1 Overall Operating Procedure</b> ..... | <b>1-2</b> |
| 1-1-1 Overall Flowchart .....                | 1-2        |

# 1-1 Overall Operating Procedure

This section describes the overall flow of use of the wireless pushbutton switches system.

## 1-1-1 Overall Flowchart

The wireless pushbutton switches system, which consists of the A2W-R□□-WC1 Mater Unit and A2W-T□-WC1 Slave button, can be used with the following procedure. For details, refer to each section.

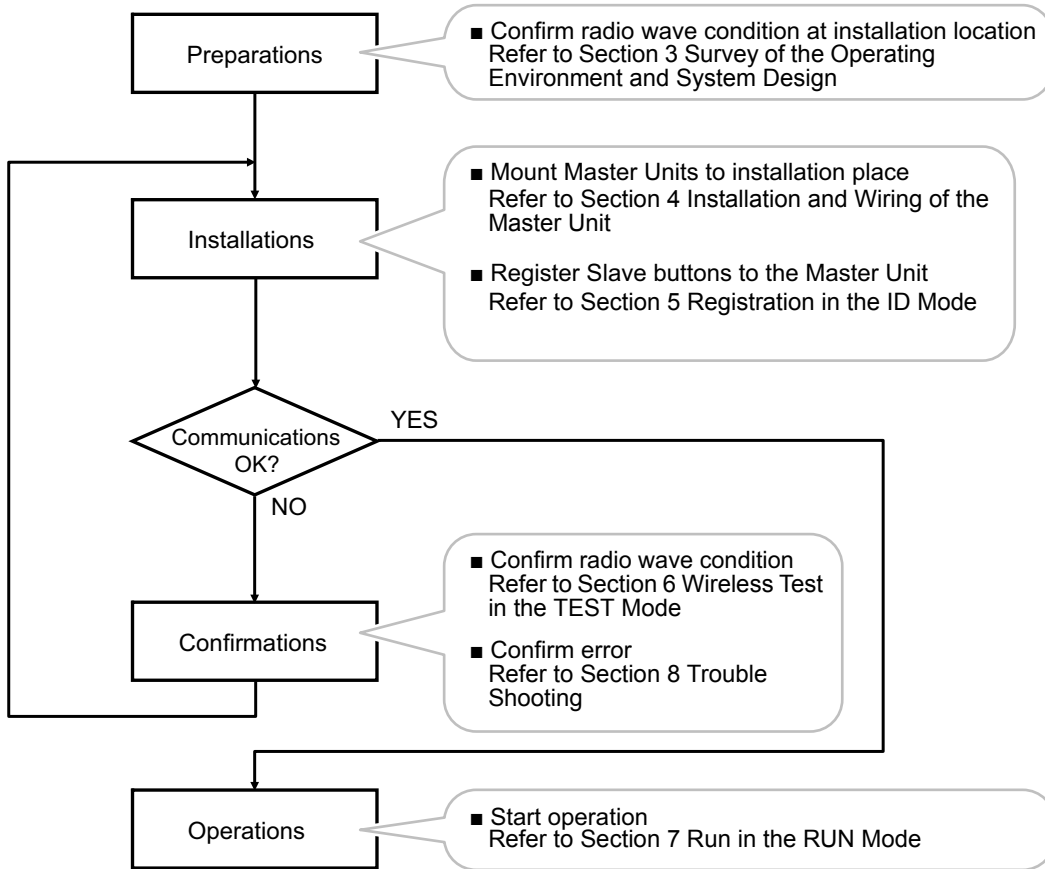

# 2

## Overview

This section describes the overview of the wireless pushbutton switches system and the nomenclature.

---

|  |             |
|--|-------------|
| <b>2-1 Overview and Features</b> .....   | <b>2-2</b>  |
| 2-1-1 Overview .....   | 2-2         |
| 2-1-2 Features .....   | 2-3         |
| 2-1-3 Major Application Examples .....   | 2-3         |
| <b>2-2 System Configurations</b> .....   | <b>2-4</b>  |
| 2-2-1 Using the Pencil Antenna Standard Included .....                                 | 2-4         |
| 2-2-2 Using Optional High-sensitivity Magnetic-base Antenna .....                      | 2-5         |
| 2-2-3 Relationship Between Slave Buttons and Master Unit .....                         | 2-6         |
| <b>2-3 List of Models</b> .....  | <b>2-8</b>  |
| 2-3-1 Master Unit and Option .....   | 2-8         |
| 2-3-2 Slave Button and Options .....   | 2-9         |
| <b>2-4 Nomenclature and Functions</b> .....  | <b>2-10</b> |
| 2-4-1 Master Unit .....  | 2-10        |
| 2-4-2 Slave Button .....   | 2-14        |
| <b>2-5 Specifications and Functions</b> .....  | <b>2-15</b> |
| 2-5-1 Wireless Specifications .....  | 2-15        |
| 2-5-2 Ratings .....  | 2-16        |
| 2-5-3 Operation Mode .....   | 2-18        |
| 2-5-4 Assignment Relationship Between Slave Button and Outputs of<br>Master Unit ..... | 2-18        |

## 2-1 Overview and Features

This section describes the overview and features of the wireless pushbutton switches system.

### 2-1-1 Overview

The wireless pushbutton switches system consists of A2W-R□□-WC1 Master Units and A2W-T□□-WC1 Wireless Pushbutton Switches. At the push button switches side, it has no wiring (i.e., wireless) and no power supply. The operation signal of the Wireless Pushbutton Switches is transmitted to the Master Unit, and transistor output is made from the Master Unit.

This system can reduce disconnection troubles occurring in the equipment using existing wired switches and can reduce time and expense when changing the layout.

Reliability is improved by wireless communications functions such as sub GHz band, master-slave communications, and reception confirmation LEDs.

Hereafter, the A2W-T□□-WC1 Wireless Push Button will be called "Slave button" in comparison with the "Master Unit".

### Overview of the System Configurations

The Overview of the wireless pushbutton switches system is shown below.

Pressing the Wireless Pushbutton Switch will be generated self-generated power. Using the power, the operation signal is transmitted wirelessly to the Master Unit. Receiving the operation signal, the Master Unit returns the reception confirmation signal to the Wireless Pushbutton Switches by radio and outputs a one shot (i.e., 500 ms) transistor output to the external devices such as PLCs.

External devices such as PLCs output signals from the Master Unit to the Display board and programmable terminal (PT), etc.

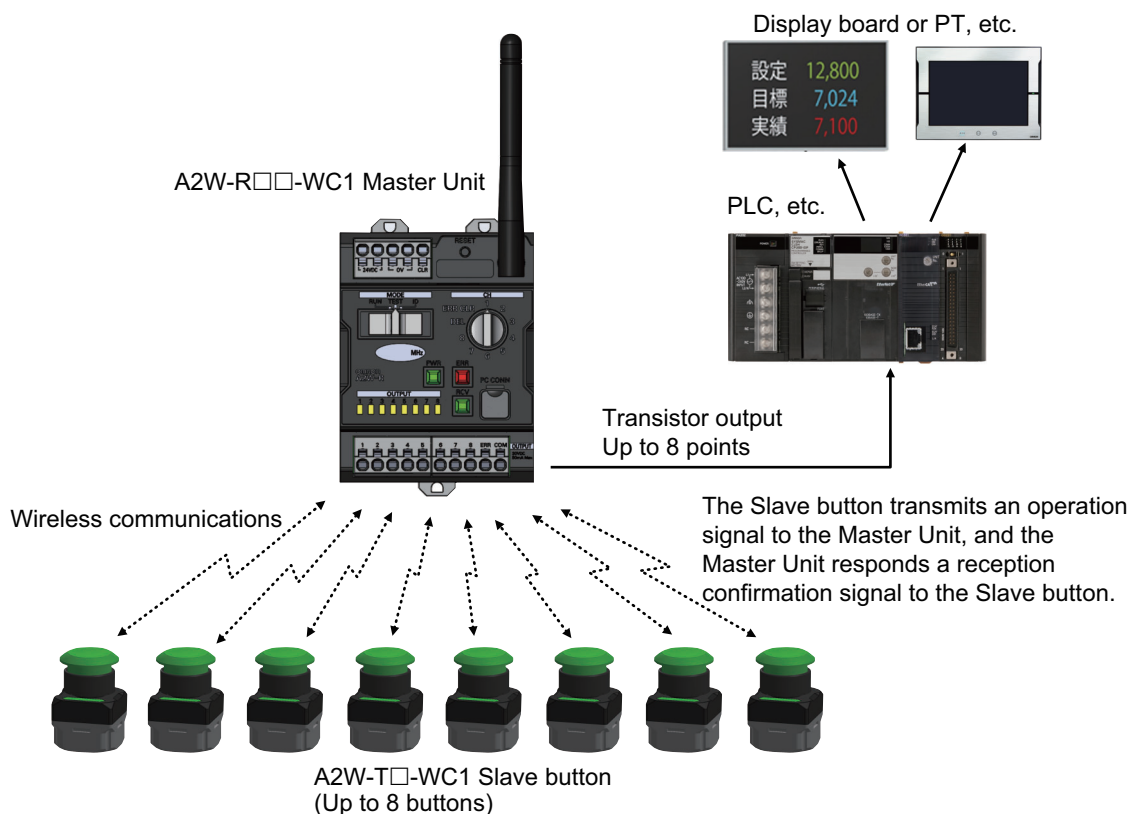

## 2-1-2 Features

The Wireless pushbutton switch system has the following features.

- Up to eight Slave buttons (pushbutton switches) can be assigned to one Master Unit.
- Self-power generation by button operation eliminates the power supply for Slave buttons (pushbutton switches). That allows you to carry Slave buttons.
- The transistor output from the Master Unit is a one-shot operation.
- Master-slave wireless communications are realized by sending ON/OFF data from the Slave buttons to the Master Unit and responding reception confirmation to the Slave buttons from the Master Unit.
- The radio frequency in the sub GHz band used enhances the characteristics that radio waves reach and goes around, and also makes it suitable for use in places with many obstacles.
- When you press the Slave button (pushbutton switch), you can confirm the success or failure of transmission with the Master Unit by the color of Slave button's indicator. Therefore, even in places where wireless communications are unstable, you can check the transmission and reception results by retrying the operation.
- A High-sensitivity Magnetic-base Antenna is provided to place the antenna in a position avoiding obstacles. This antenna is available when installing the Master Unit inside a control panel.
- Multiple Slave buttons can be assigned to the same output number of one Master Unit. (Up to 8 Slave buttons can be registered to one Master Unit.)

## 2-1-3 Major Application Examples

Wireless pushbutton switches can be used for the following applications.

- Notifying ON/OFF information (e.g., people call, missing item information, work completion notification)
- Instructions to automatic guided vehicles (e.g., instruction to stop)
- Instructions from manned guided vehicles (e.g., Instructions for opening and closing shutters or doors of warehouses)
- Instructions to the machine (e.g., stopping, inching, opening and closing doors)

## 2-2 System Configurations

This section describes the system configurations of the wireless pushbutton switches.



### Precautions for Correct Use

After pressing a Slave button, wait for 100 ms before pressing the next Slave button, because the Master Unit can not receive at the same time signals of multiple Slave buttons.

### 2-2-1 Using the Pencil Antenna Standard Included

The system configuration diagram when the Pencil antenna is connected to the Master Unit is shown below.

### System Configuration

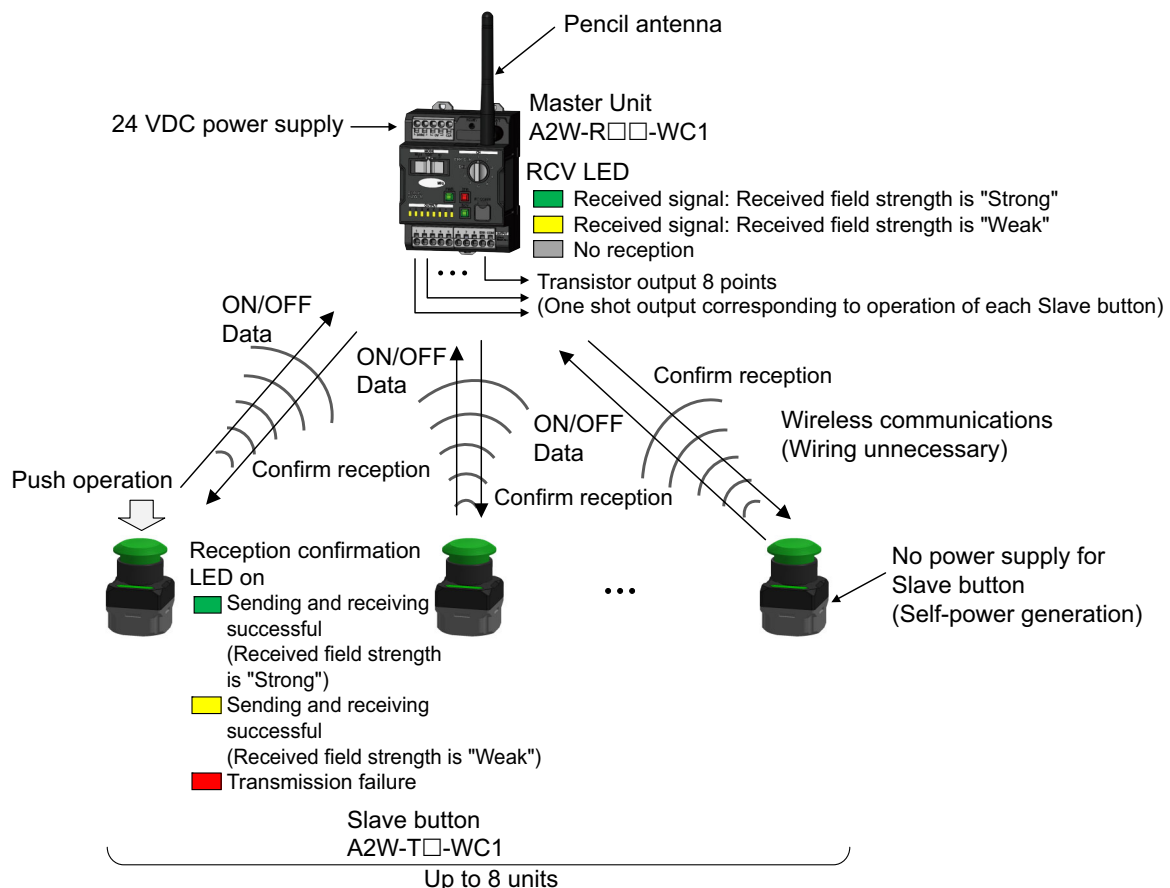

When using the Pencil antenna that comes with the Master Unit, do not install the antenna in a metal panel, because the wireless performance is significantly reduced. When installing the Master Unit in a panel, use the High-sensitivity Magnetic-base Antenna so that the antenna can be installed outside the panel.



## 2-2-2 Using Optional High-sensitivity Magnetic-base Antenna

The following is a system configuration diagram when the High-sensitivity Magnetic-base Antenna is connected to the Master Unit.

### System Configuration

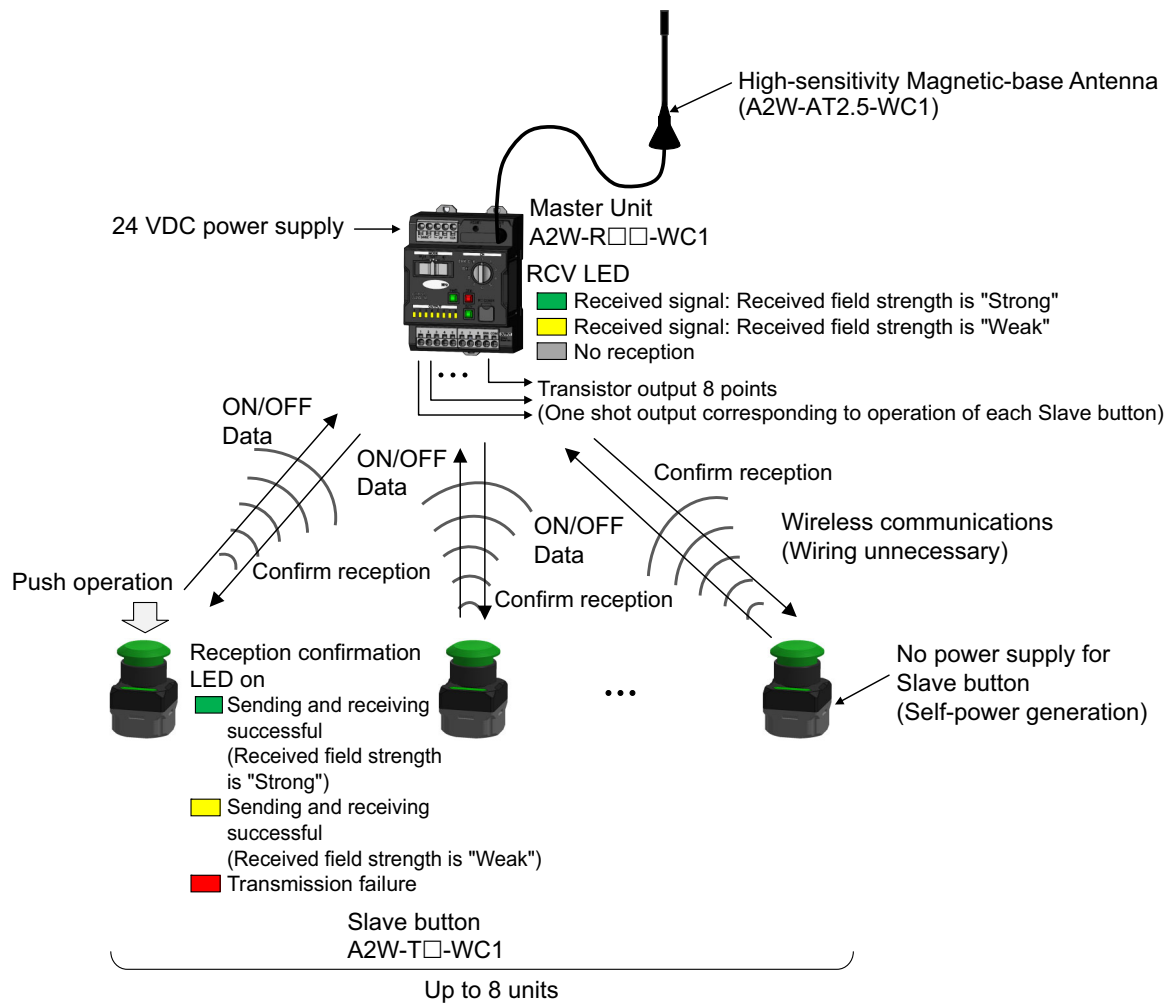

### 2-2-3 Relationship Between Slave Buttons and Master Unit

Up to 8 Slave buttons can be assigned to one Master Unit.

A single Master Unit can output eight transistors.

- A single Slave button can be assigned to each output of the Master Unit.
- In addition, the following duplicate assignments are also possible.
  - (a) Multiple Slave buttons can be assigned to the same output of the Master Unit.

Observe the following precautions in this case.

If you press the Slave button successively at short intervals (i.e., within 500 ms), not all actions of multiple Slave buttons pressed within 500 ms will be reflected. Only the actions of the Slave button pushed at the beginning is reflected in the "RCV" LED and output of the Master Unit.

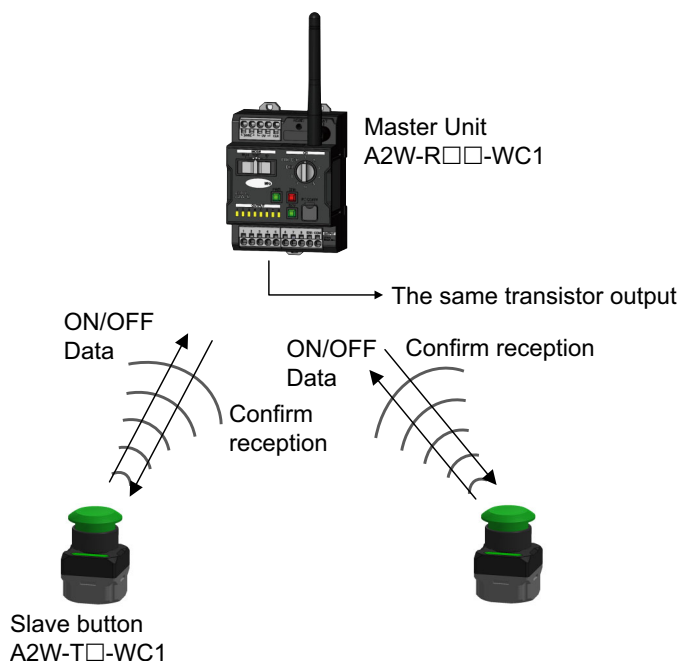

(b) A single Slave button can be assigned to multiple outputs of the Master Unit in duplicate.

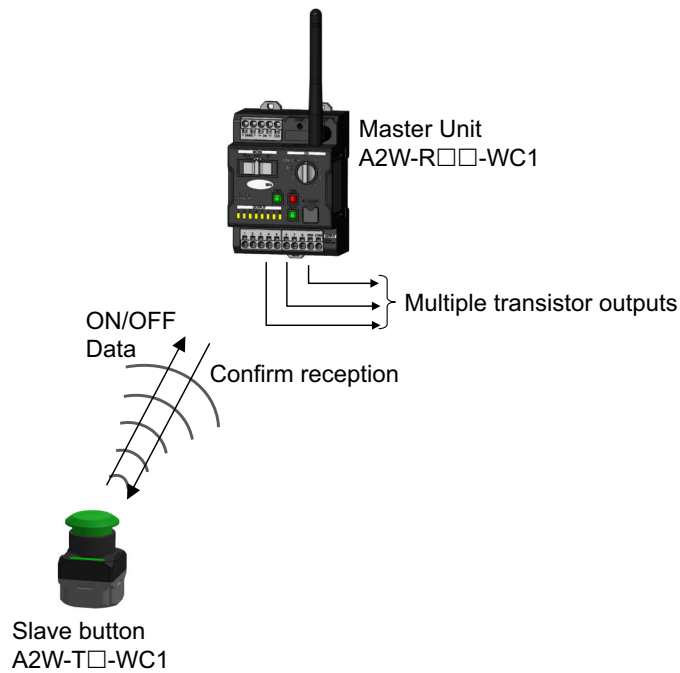

For details, refer to the 2-5-4 Assignment Relationship Between Slave Button and Outputs of Master Unit on page 2-18.

 **Additional Information**

Assignment of the same Slave button to multiple Master Units.

The same Slave button can be assigned to any of output of the multiple Master Units.

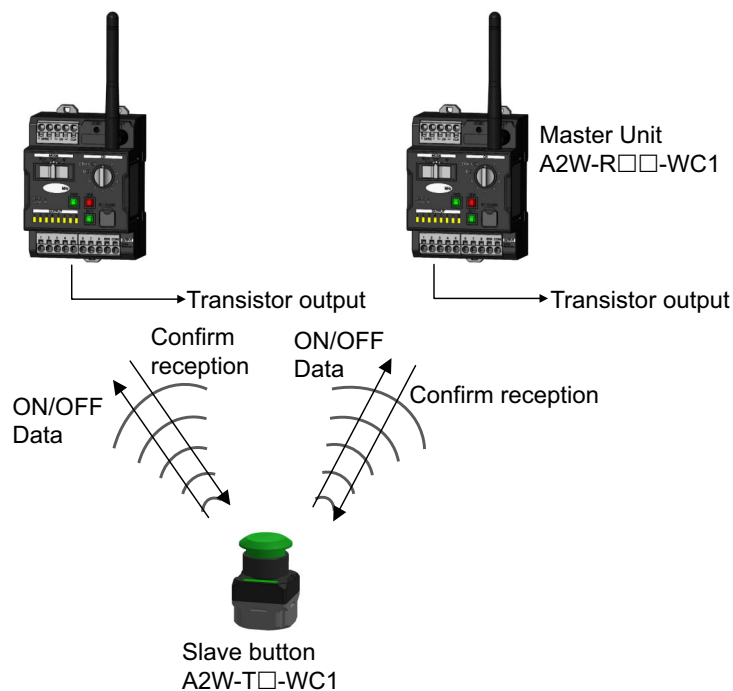

Be aware that the transmission results from the Master Units may not be reflected on the operation LED of the Slave button as one Slave button is assigned to the multiple Master Units.

## 2-3 List of Models

This section shows models of the components of the wireless pushbutton switches system and its option.

### 2-3-1 Master Unit and Option

#### Master Unit

| Model         | Name        | Specifications  |
|---------------|-------------|---|
| A2W-□□□-WC□□□ | Master Unit | <ul style="list-style-type: none"> <li>• Wireless communications reception from up to eight Slave buttons</li> <li>• Eight transistor outputs of one shot (500 ms)</li> <li>• Power supply: 24 VDC</li> </ul> |

A2W- □ □ □ - WC □ □ □

(1) (2) (3) (4) (5)

| Number | Type                 | Symbol | Specifications          |
|--------|----------------------|--------|-------------------------|
| (1)    | ---                  | R      | Master Unit             |
| (2)    | Frequency            | A      | 929.2 MHz               |
|        |                      | B      | 868.3 MHz               |
|        |                      | C      | 922.5 MHz               |
| (3)    | Output Configuration | N      | Sinking output          |
|        |                      | P      | Sourcing output         |
| (4)    | Protocol             | 1      | OMRON's protocol        |
| (5)    | Area                 | JP     | Japan                   |
|        |                      | US     | United States or Canada |
|        |                      | MX     | Mexico                  |
|        |                      | EU     | Europe (EU)             |
|        |                      | BR     | Brazil                  |

Note Be sure to use the models for the corresponding area. When used in a country other than the corresponding area, it becomes illegal under the radio law of each country.

#### Option (sold separately)

| Model         | Name   | Usage  |
|---------------|--|--|
| A2W-AT2.5-WC1 | High-sensitivity<br>Magnetic-base<br>Antenna | <ul style="list-style-type: none"> <li>• For antenna draw out to outside the panel</li> <li>• Frequency: All frequency supported</li> <li>• Cable length: 2.5 m</li> </ul> |

## 2-3-2 Slave Button and Options

### Slave Button

| Model           | Name                                | Specifications   |
|-----------------|-------------------------------------|--|
| A2W-□□-WC□□□□□□ | Wireless Push Button (Slave button) | <ul style="list-style-type: none"> <li>When you press the button, send an ON /OFF signal to the Master Unit wirelessly.</li> <li>A single built-in operation LED for confirming wireless operation to the Master Unit</li> <li>Unnecessary power supply for Slave button (self-generated by button operation)</li> </ul> |

A2W- □ □ - WC □ □ □ □ □ □  
 (1) (2) (3) (4) (5) (6) (7)

| Number | Type              | Symbol | Specifications          |
|--------|-------------------|--------|-------------------------|
| (1)    | ---               | T      | Slave button            |
| (2)    | Frequency         | A      | 929.2 MHz               |
|        |                   | B      | 868.3 MHz               |
|        |                   | C      | 922.5 MHz               |
| (3)    | Protocol          | 1      | OMRON's protocol        |
| (4)    | Area              | JP     | Japan                   |
|        |                   | US     | United States or Canada |
|        |                   | MX     | Mexico                  |
|        |                   | EU     | Europe (EU)             |
|        |                   | BR     | Brazil                  |
| (5)    | Button appearance | 1      | Mushroom                |
|        |                   | 2      | Full guard              |
| (6)    | Button color      | R      | Red                     |
|        |                   | G      | Green                   |
|        |                   | Y      | Yellow                  |
|        |                   | A      | Blue                    |
|        |                   | W      | White                   |
|        |                   | B      | Black                   |
| (7)    | Flange color      | R      | Red                     |
|        |                   | Y      | Yellow                  |
|        |                   | B      | Black                   |

Note Be sure to use the models for the corresponding area. When used in a country other than the corresponding area, it becomes illegal under the radio law of each country.

### Options (sold separately)

| Model     | Name                | Usage                |
|-----------|---------------------|----------------------|
| A2W-H-WC1 | Slave button holder | For installation use |
| A2W-S-WC1 | Slave button strap  | For portable use     |

## 2-4 Nomenclature and Functions

This section describes the nomenclature and functions of the Master Unit and Slave buttons of the wireless pushbutton switches system.

### 2-4-1 Master Unit

#### Nomenclature

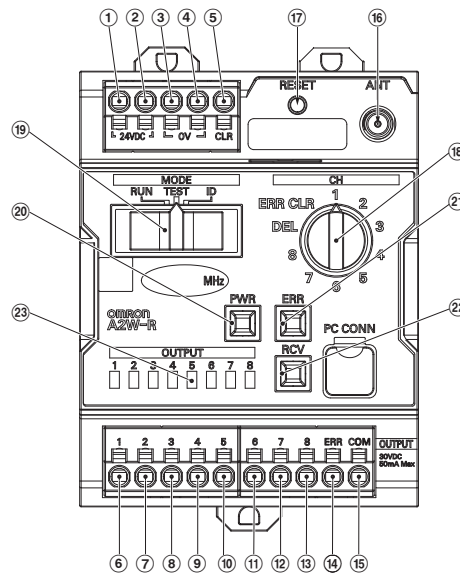

| Number | Terminal name | Name                        | Function  |
|--------|---------------|-----------------------------|---|
| ①      | 24 VDC        | Power supply terminals      | Supply 24 VDC.  |
| ②      | 24 VDC        |                             |   |
| ③      | 0 V 1         |                             |   |
| ④      | 0 V 2         |                             |   |
| ⑤      | CLR           | Error clear terminal        | Short to 0 V terminal when resetting the error output.  |
| ⑥      | OUT 1         | Output terminals            | Connect the output signal line.<br>There are two types of output: sinking and sourcing as flows.<br><ul style="list-style-type: none"> <li>• A2W-R□N-WC1□□: Sinking output</li> <li>• A2W-R□P-WC1□□: Sourcing output</li> </ul> |
| ⑦      | OUT 2         |                             |   |
| ⑧      | OUT 3         |                             |   |
| ⑨      | OUT 4         |                             |   |
| ⑩      | OUT 5         |                             |   |
| ⑪      | OUT 6         |                             |   |
| ⑫      | OUT 7         |                             |   |
| ⑬      | OUT 8         |                             |   |
| ⑭      | ERR           | Error output terminal       | Connect the error output signal line.<br>There are two output types: sinking and sourcing.<br><ul style="list-style-type: none"> <li>• A2W-R□N-WC1□□: Sinking Outputs</li> <li>• A2W-R□P-WC1□□: Sourcing Outputs</li> </ul>     |
| ⑮      | COM           | Common terminal for outputs | Used as common for output and error output.   |
| ⑯      | ---           | Antenna terminal            | Connect the included pencil antenna.<br>(Optional antenna A2W-AT2.5-WC1 can also be connected.)<br>It transmits and receives data by wireless communications via the antenna.   |

| Number | Terminal name | Name                        | Function  |
|--------|---------------|-----------------------------|---|
| ⑰      | ---           | Reset switch                | <ul style="list-style-type: none"> <li>Delete the Slave button registration information corresponding to the output settings switch.</li> <li>By pressing the output settings switch in the "ERR CLR" state when an error output is generated, error output will be reset.</li> <li>When the power is turned ON in the pressed state, it is reset to the factory setting.</li> </ul>  |
| ⑱      | ---           | Output settings switch      | Used to register or delete the ID of the Slave button to or from the output of the Master Unit.<br>Also used to reset the error output without using the error clear terminal.  |
| ⑲      | ---           | Mode settings switch        | Set the operation mode of the Master Unit to ID mode, TEST mode, and RUN mode.  |
| ⑳      | ---           | Power supply LED            | Lit green when the power is ON.   |
| ㉑      | ---           | Error LED                   | Lit red when there is a possibility that abnormality occurs in the master unit and it will not output correctly according to the Slave button operation.  |
| ㉒      | ---           | Received field strength LED | <ul style="list-style-type: none"> <li>RUN mode, or TEST mode<br/>It lights according to the received electric field strength of the received data.<br/>Lit green: Received field strength is "Strong"<br/>Lit yellow: Received field strength is "Weak"</li> <li>ID registration mode<br/>Lit green when registration or deletion is success.<br/>Flashing green when registration or deletion is failure.</li> <li>When error output occurs<br/>Lit green when the Master Unit setting data error is detected.<br/>Lit yellow when there is a possibility that the Master Unit will not output properly according to the Slave button operation.</li> </ul> |
| ㉓      | ---           | Output LED                  | <ul style="list-style-type: none"> <li>RUN mode<br/>When outputting to the output terminal, the corresponding output LED lit yellow.</li> <li>TEST mode<br/>It does not output to the output terminal, and the corresponding output LED lit yellow.</li> <li>ID mode<br/>The output LED corresponding to the output setting switch lit yellow.</li> </ul>   |

## Display

| LED name                         | Color           | Enabled mode  | Status               | Meaning   |
|----------------------------------|-----------------|---|----------------------|---|
| PWR                              | Green           | Always enabled  | Lit                  | During Power Supply   |
|                                  |                 |   | Not lit              | No power supplied   |
| RCV                              | Green or Yellow | RUN/TEST  | Lit/Not lit          | Received field strength monitor:<br>Lit green: Received field strength is "Strong" (lit up for 500 msec)<br>Lit yellow: Received field strength is "Weak" (lit up for 500 msec)<br>Not lit: No received     |
|                                  |                 | ID  | Lit/Not lit/Flashing | ID registration:<br>Lit green: ID registration successful (lit up for 3 s)<br>Not lit: Data for ID registration not received<br>Flashing green: ID registration failed (flashes for 3 s after every 250 ms) |
|                                  |                 |   |                      | Delete ID:<br>Lit green: ID deletion successful (lit up for 3 s)<br>Not lit: Data for ID deletion not received<br>Flashing green: ID deletion failed (flashes for 3 s after every 250 ms)                   |
| Enabled only when ERR LED is lit | Lit/Not lit     | Lit green: Error in Master Unit setting data<br>Lit yellow: Error in the most important function (wireless received, registration/verification, or output)<br>All not lit: Error in CPU initialization process during startup |                      |   |

| LED name         | Color  | Enabled mode   | Status      | Meaning  |
|------------------|--------|----------------|-------------|--|
| OUTPUT<br>1 to 8 | Yellow | RUN/TEST       | Lit         | Data is received from the ID assigned to the corresponding output  |
|                  |        |                | Not lit     | Data is not received from the ID assigned to the corresponding output  |
|                  |        | ID             | Lit         | Reads corresponding output settings switch values 1 to 8   |
|                  |        |                | All lit     | Reads output settings switch value DEL   |
|                  |        |                | All not lit | Reads output settings switch value ERR CLR   |
| ERR              | Red    | Always enabled | Lit         | Error in CPU initialization processing at startup, or in Master Unit setting data, or in the most important function (wireless received, registration/verification, or output) |
|                  |        |                | Not lit     | No Master Unit error   |

### ● Each State Corresponding to the Combination of "ERR" LED and "RCV" LED

In the RUN Mode or the TEST Mode

| ERR     | RCV        | Status   |
|---------|------------|--|
| Lit red | Lit green  | Master Unit setting data error   |
|         | Lit yellow | The most important function error  |
|         | Not lit    | CPU initialization processing error  |
| Not lit | Lit green  | No Master Unit error and with reception.<br>Received field strength: "Strong". |
|         | Lit yellow | No Master Unit error and with reception.<br>Received field strength: "Weak".   |
|         | Not lit    | No Master Unit error and without reception.                                    |

ID Mode

| ERR     | RCV            | Status   |
|---------|----------------|--|
| Lit red | Lit green      | Master Unit setting data error   |
|         | Lit yellow     | The most important function error  |
|         | Not lit        | CPU initialization processing error  |
| Not lit | Lit green      | No Master Unit error, and ID registration success or ID deletion success                             |
|         | Flashing green | No Master Unit error, and ID registration failure or ID deletion failure                             |
|         | Not lit        | No Master Unit error, and no data reception for ID registration or no data reception for ID deletion |

Note The strength of receiving field (RCV) will also flash green even if you select an output number that is not registered as ID and try to erase or reset.



## Setting Switches

### ● Mode Settings Switch

Set the operation mode of the Master Unit.

Factory setting: ID

| Operation mode | Function   |
|----------------|--|
| RUN            | Communications mode: Normal communications   |
| TEST           | Test mode: Installation tests such as reception strength measurement, etc.<br>* There is no output from the output terminal. |
| ID             | ID mode: Register or delete Slave buttons  |

### ● Output Settings Switch

Register or delete the Slave button ID <sup>\*1</sup> for each output number of the Master Unit.

Factory setting: 1

| Number  | Enabled mode                               | Other settings requirements   | Function   |
|---------|--|---|--|
| 1 to 8  | ID   | Continuous data reception within a fixed period from the Slave button to be registered                            | Register the ID of the target Slave button to be registered in the specified output number |
|         |  | Press the Reset switch (ON)   | Delete IDs of all Slave buttons registered in the specified output number                  |
| DEL     |  | Continuous data reception within a fixed period from the Slave button for which the registration is to be deleted | Delete the ID of the Slave button to be deleted from the registration list                 |
|         |  | Press the Reset switch (ON)   | Delete all IDs from the registration list  |
| ERR CLR | ERR LED lit red<br>+<br>RCV LED lit yellow | Press the Reset switch (ON)   | Execute the software reset of the Master Unit  |

\*1. This is the identification number of the Slave button for wireless communications.

## 2-4-2 Slave Button

### Nomenclature

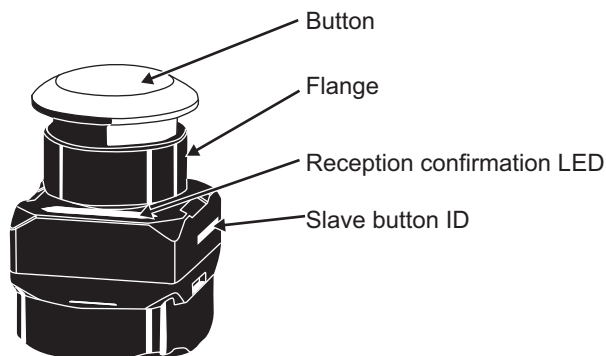

### Reception Confirmation LED

| Display color | Description   |
|---------------|---|
| Green         | Transmission/reception success (Strength of receiving field: Strong)    |
| Yellow        | Transmission/reception success (Strength of receiving field: Weak)      |
| Red           | Transmission/reception failure  |
| Not lit       | Slave button malfunction (No signal transmission from the Slave button) |



#### Precautions for Correct Use

If a Slave button are assigned to multiple Master Units, the reception confirmation LED on the Slave button will light green or yellow when transmission and reception with a Master Unit succeeds.

Therefore, even if there are Master Units that failed to send and receive, you may not catch it only by the reception confirmation LED on the Slave button. Make sure that the system is kept safe even in such a case.

### What is a Slave Button ID?

It is the unique identification number for each Slave button. Assign this ID to the output number of the Master Unit and register the Slave button.

## 2-5 Specifications and Functions

This section shows the wireless specifications of the wireless pushbutton switches system, the Master Unit, and the Slave button.

### 2-5-1 Wireless Specifications

The specifications of the radio used with the wireless pushbutton switches system are as follows.

| Item                                       | Slave button model  | A2W-TA-WC1 JP□□□ | A2W-TB-WC1 □□□□□      | A2W-TC-WC1 □□□□□ |
|--|---|------------------|-----------------------|------------------|
|  | Master Unit model   | A2W-RA□-WC1 JP   | A2W-RB□-WC1 □□        | A2W-RC□-WC1 □□   |
| Set frequency                              | 929.2 MHz   |                  | 868.3 MHz             | 922.5 MHz        |
| Frequency channel                          | 1 channel   |                  |                       |                  |
| Transmission power                         | 1 mW max.   |                  | 5 mW [e.r.p.] or less | 50 mV/m max.     |
| Wireless service area communications speed | 100 kbit/s  |                  |                       |                  |
| Communications method                      | Simplex communications  |                  |                       |                  |
| Number of wireless pushbuttons connected   | 8 max.  |                  |                       |                  |
| Communications distance (line of sight)    | Approx. 100 m outdoors (with the included pencil antenna)               |                  |                       |                  |
| Transmission time                          | Approx. 3 ms (from slave button transmission to slave button reception) |                  |                       |                  |
| Repeater function                          | Not supported.  |                  |                       |                  |

## 2-5-2 Ratings

The ratings of the Master Unit and Slave buttons are as follows.

### Master Unit

|                                     | Item                                | Specifications  |
|-------------------------------------|-------------------------------------|---|
| Master Unit power supply            | Rated voltage                       | 24 VDC  |
|                                     | Allowable voltage range             | 21.6 to 26.4VDC   |
|                                     | Current consumption                 | 2.4 W max.  |
|                                     | Input current                       | 0.1 A max.  |
| Output rated                        | Output points                       | Output 8 points<br>One other point for error output   |
|                                     | Output circuit shared voltage       | 30 VDC max.   |
|                                     | Maximum load current                | 50 mA per point   |
|                                     | Leakage current                     | 0.1 mA max.   |
|                                     | Residual voltage                    | 2.0 V max.  |
|                                     | Output logic                        | One-shot (500 ms)   |
|                                     | Response time                       | 30 ms or less (from Slave button transmission to Master Unit signal output)   |
| Error clear terminal                | Number of connected slave buttons   | 8 max.  |
|                                     | Residual voltage at short           | 1.5 V or less, ON   |
| Insulation resistance               | Leakage current                     | 0.1 mA or less, OFF (current at short: approx. 7 mA)  |
|                                     | Insulation resistance               | 20 MΩ max. (100 VDC)<br>Between the case and power supply terminals and all outputs terminals<br>Between all power supply terminals and all outputs terminals |
| Dielectric strength                 | Dielectric strength                 | 1,000 VAC, 1 min.<br>Between the case and power supply terminals and all outputs terminals<br>Between all power supply terminals and all outputs terminals    |
|                                     | Vibration resistance                | Frequency: 10 to 55 Hz, half amplitude: 0.42 mm<br>3-Directional, 120 minutes each (1 sweep, 1 min. ×120 sweeps)  |
| Shock resistance                    | Shock resistance                    | 150 m/s <sup>2</sup><br>Direction of shock: 3-axis, 6 directions<br>Shock frequency: 3 × each direction, total 18   |
| Ambient operating temperature range | Ambient operating temperature range | -10 to +55°C (no condensation or icing)   |
| Ambient operating humidity range    | Ambient operating humidity range    | 20% to 90% (no condensation)  |
| Atmosphere                          | Atmosphere                          | No corrosive gas  |
| Storage temperature range           | Storage temperature range           | -40 to +70°C (no condensation or icing)   |
| Storage humidity range              | Storage humidity range              | 20% to 90% (no condensation)  |
| Degree of protection                | Degree of protection                | IP20  |
| Altitude                            | Altitude                            | 2,000 m max.  |
| Memory protection                   | Memory protection                   | Non-volatile memory (Number of write operations: 1,000,000)   |
| Weight                              | Weight                              | 150 g (not including antenna)<br>160 g (including antenna)  |
|                                     | Mounting                            | DIN rail mounting<br>Screw mounting   |

## ● Output Circuits Diagram of the Power Supply Terminals

Output/Error output circuits diagram (sinking)

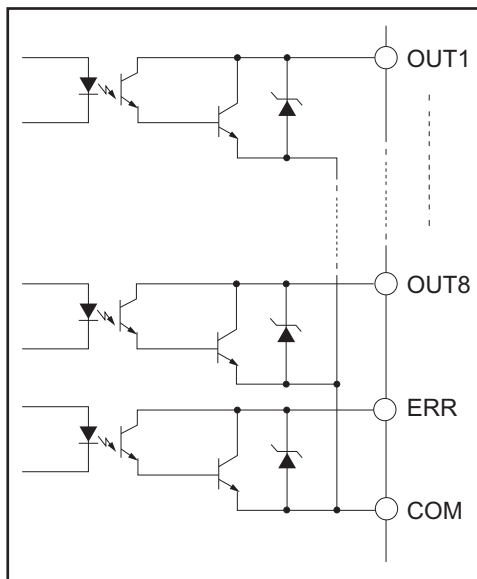

Output/Error output circuits diagram (sourcing)

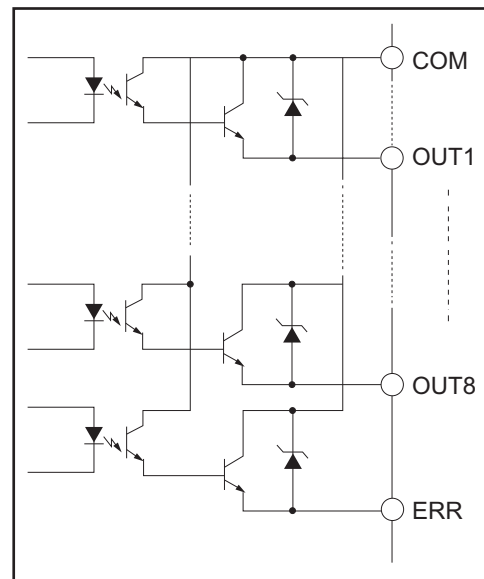

## Slave Button

| Item                                | Specifications   |
|-------------------------------------|--|
| Operating force                     | 25 N max.  |
| Number of operations                | 1,000,000 operations   |
| Vibration resistance                | Frequency: 10 to 55 Hz, 0.75-mm single amplitude for 2 h, sweeps of 5 min. |
| Shock resistance                    | 1,000 m/s <sup>2</sup> min., 3 times each in 6 directions                  |
| Ambient operating temperature range | -10 to + 55 °C (with no condensation icing)                                |
| Ambient operating humidity range    | 20% to 90% (with no condensation)  |
| Atmosphere                          | No corrosive gas   |
| Ambient storage temperature range   | -40 to + 70 °C (with no condensation or icing)                             |
| Ambient storage humidity range      | 20% to 90% (with no condensation)  |
| Degree of protection                | IP65   |
| Altitude                            | 2,000 m max.   |
| Weight                              | 100 g max.   |

### 2-5-3 Operation Mode

The Master Unit has the following operation modes.

| Operation mode | Mode name           | Function   |
|----------------|---------------------|--|
| RUN            | Communications mode | Receives data from the Slave button and performs transistor output. (During normal operation)        |
| TEST           | Test mode           | Even if data is received from the Slave button, transistor output is not performed. (During testing) |
| ID             | ID mode             | Register or delete the Slave button ID. (When setting)   |

The operation mode can be switched by the mode settings switch of Master Unit.

### 2-5-4 Assignment Relationship Between Slave Button and Outputs of Master Unit

All assignments can be made between 8 Slave buttons and 8 outputs of the Master Unit.

Duplicate assignment is possible. A total of  $8 \times 8 = 64$  patterns can be assigned.

- Multiple Slave buttons can be assigned to the same output.
- The same Slave button can be assigned to multiple outputs of the Master Unit.
- The above combinations are also possible.

Examples of various assignments are shown below.

For additional reference information, the ladder diagram circuit equivalent to the OR logic is shown on the right side.

#### Multiple Slave Buttons Are Assigned to the Same Output

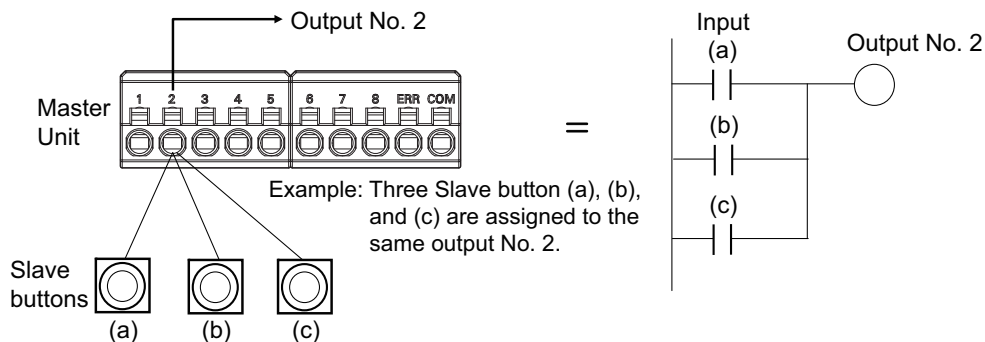

In the above example, when operating either of Slave button (a), (b), or (c) once, the No.2 output will be outputted in one shot.

## One Slave Button is Assigned to Two or More Outputs

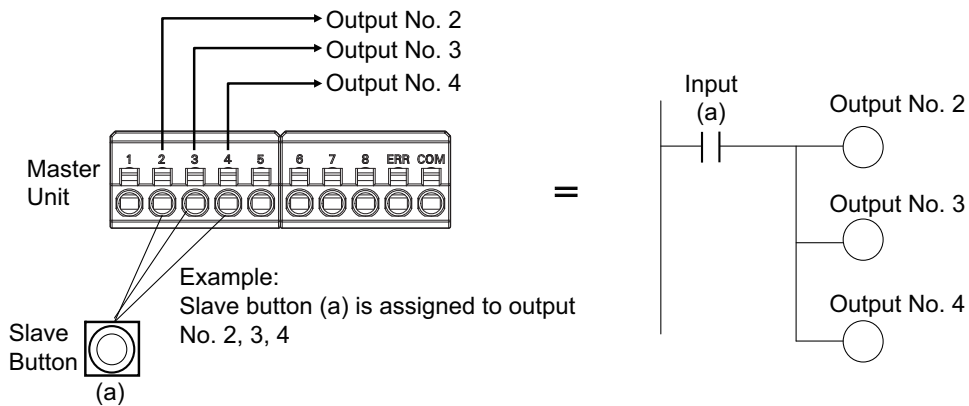

In the above example, when operating one Slave button (a) once, the No.2, No.3 and No.4 outputs will be outputted in one shot.

## Combinations of Above

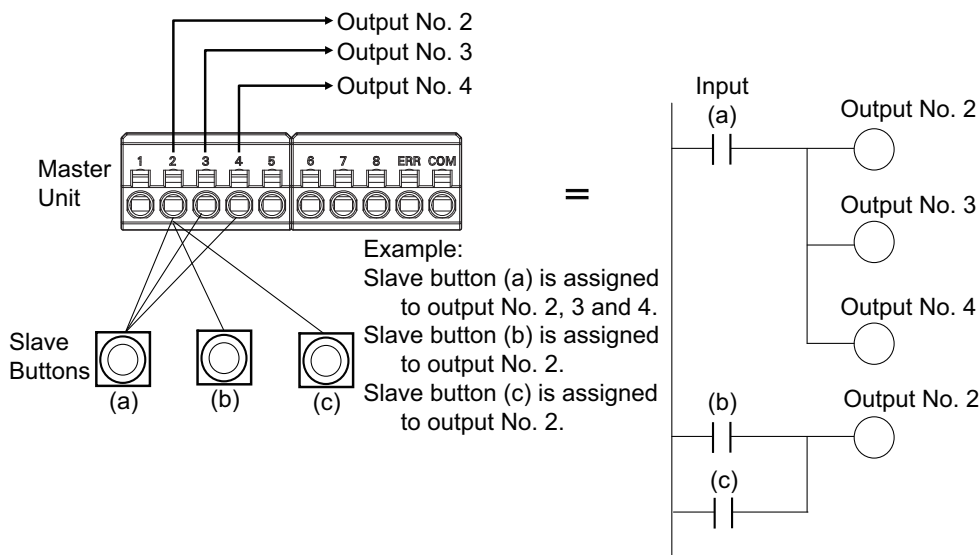

In the above example, when operating one Slave button (a) once, the No.2, No.3 and No.4 outputs will be outputted in one shot.

Also, when operating either of Slave button (b) or (c) once, the No.2 output will be outputted in one shot.





# 3

## Survey of the Operating Environment and System Design

This section describes how to check the operating environment of the wireless push-button switches system.



---

|            |   |            |
|------------|---|------------|
| <b>3-1</b> | <b>Installation and Operating Environment</b> | <b>3-2</b> |
| <b>3-2</b> | <b>Operation Timing Chart</b>                 | <b>3-5</b> |
| 3-2-1      | Operation Timing Chart                        | 3-5        |

## 3-1 Installation and Operating Environment

This section describes the installation and operating environment of the wireless pushbutton switches system.

Before installing the Wireless Pushbutton switches System, make sure to confirm that the radio wave condition at the installation site is good by temporarily installing.

|  <b>WARNING</b>  |  |
|---|--|
| Do not use this product without a protection circuit. Otherwise it may result in heavy injuries or damage on life or property due to malfunction.   |  |
| Dual or triple safety protection circuits, such as emergency stop, interlock, or limit circuit, must be configured by external control circuit so that the system should operate on safe side even if a failure of this product or an error due to an external factor occurred.   |  |
| This product is used radio waves for communications, communications may be interrupted. Depending on the surrounding environment and usage, leading to serious accidents such as severe personal injury and serious physical damage.  |  |
| Safety of the system must be maintained even in such a case. In particular, this product may be disturbed by wireless systems generating strong radio waves in the neighboring frequency band. Before starting actual operation or periodically, always perform the communications test in advance and make sure that the system operates normally before using it. |  |
| Never use this product for real-time control applications.  |  |
| Communications errors cause information to be delayed or missing in which may result in serious accidents.  |  |
| Do not use this product close to any medical equipment such as a pacemaker as it may affect operation of such medical equipment and may result in heavy injuries.   |  |

### Installation Locations

When selecting the installation locations of the Master Units, consider the following conditions:

- 24 VDC power supply can be supplied to the Master Unit
- To set the Master Unit at a relatively high position. When installing the Master Unit on the floor, the communications distance becomes short.
- Installation at a higher position will be installed in a more open space. As a result, radio waves will be more easily reachable without being affected by obstacles.

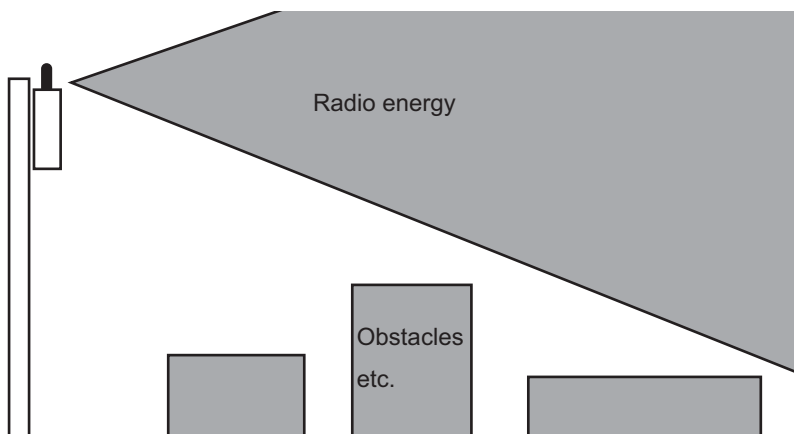

Install wireless Units as high as possible

- Do not place a metal object around the antenna.  
Metal objects reflect radio waves, so if there is a metal object around the antenna, the radio waves in a specific direction may become weak.

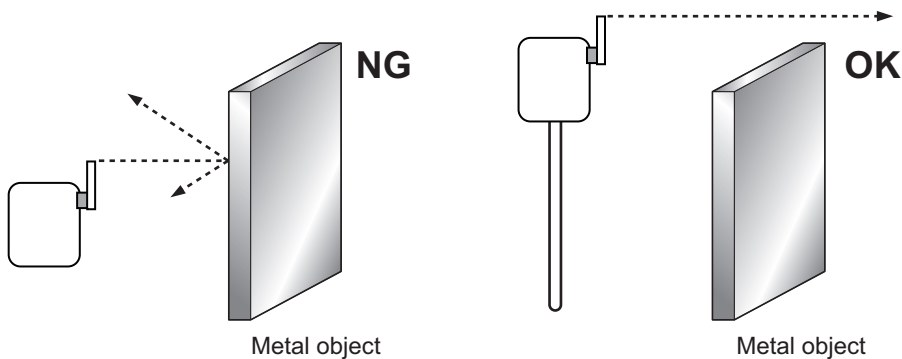

Keep the antenna away from the metal object.

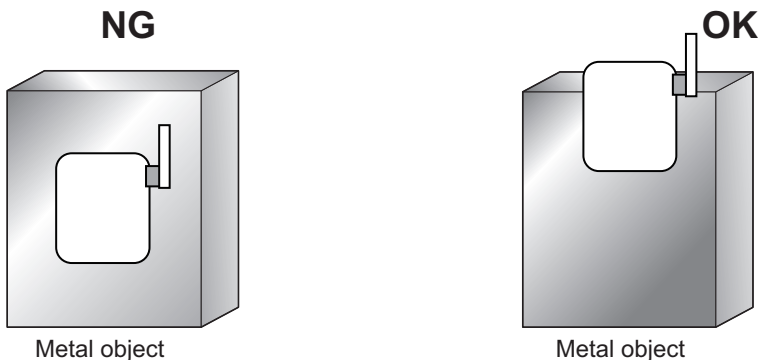

### Major Radio Wave Obstacles in the Buildings

---

- Floor and ceiling metal plates and piping
- Metal shielding (iron door, metallic shutter, etc.)
- Thermal insulation (cover with aluminum vapor deposition)
- People (moisture)
- Reinforced concrete wall
- Elevator
- Stainless steel cupboard and refrigerator in kitchen
- Steel shelves, lockers, etc.
- Power cable
- Window with iron wire

Do not install in the following place.

- Places exposed to direct sunlight.
- Where the humidity is very high.
- Near devices that transmit and receive radio waves such as television, radio, transceiver.
- Places close to mobile phone base station.
- Near the thing that sparks such as motor, drill, welder etc.
- Near the strong magnet.
- Near the fluorescent light.
- It is a place surrounded by metal belonging to the genus, concrete.



#### Additional Information

---

- Metal reflects radio waves. Therefore, if there is a metal object around the antenna, the radio waves in a specific direction weaken.
  - Water absorbs radio waves. Therefore, if there is water in the communications path, the radio wave attenuates and weakens.
-

## 3-2 Operation Timing Chart

This section describes the operation timing between the Master Unit and the Slave buttons of the wireless pushbutton switches system.

### 3-2-1 Operation Timing Chart

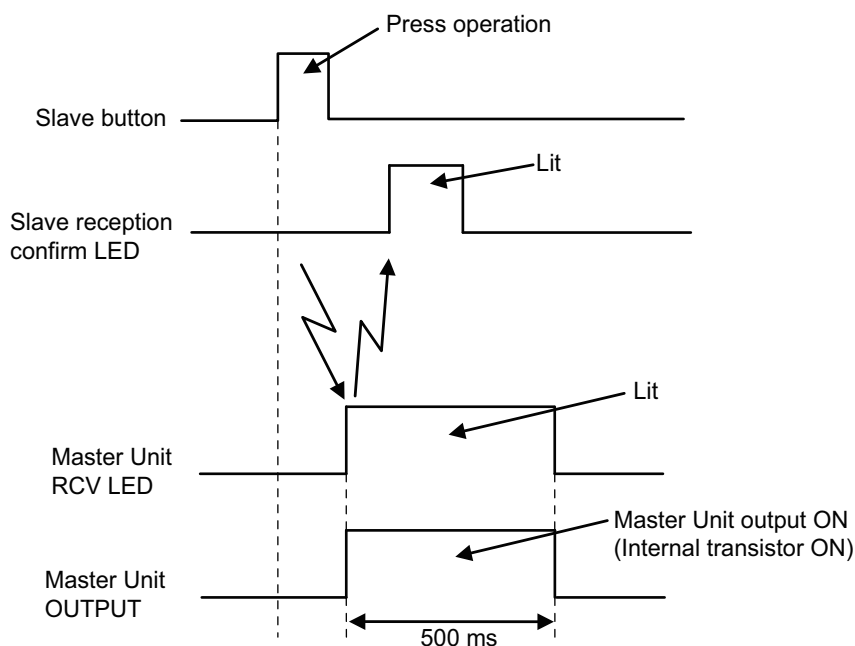

Note: If two or more Slave buttons are pressed simultaneously within 2 ms, the operation of the next Slave button and the following Slave buttons within 2 ms may not be transmitted to the Master Unit.

### Lighting Time of RCV LED and OUTPUT LED, and ON Time of Output

After pressing the Slave button, the RCV LED lights green (when the received field strength is Strong) or turns yellow (when the received field strength is Weak) for 500 ms.

At the same time, the OUTPUT LED lights up and the output turns ON for 500 ms. After that, the OUTPUT LED turns off and the output turns OFF.

Note If you press the Slave button successively at short intervals (i.e., within 500 ms).

The RCV LED lights green (when the received field strength is Strong) or turns yellow (when the received field strength is Weak) for 500 ms +  $\alpha$ .

$\alpha$ : Time difference to the next Slave button

After each Slave button is pressed, the OUTPUT LED lights up and the output turns ON for 500 ms. After that, the OUTPUT LED turns off and the output turns OFF.



# 4

## Installation and Wiring of the Master Unit

This section describes installation and wiring of the wireless pushbutton switch.

4

---

|            |   |             |
|------------|---|-------------|
| <b>4-1</b> | <b>Dimensions</b>   | <b>4-2</b>  |
| 4-1-1      | Master Unit   | 4-2         |
| 4-1-2      | Slave button  | 4-4         |
| <b>4-2</b> | <b>Installing Master Units</b>                                  | <b>4-6</b>  |
| 4-2-1      | DIN Rail Installation   | 4-6         |
| 4-2-2      | Screw Mounting  | 4-8         |
| 4-2-3      | Using the Magnetic-base Antenna                                 | 4-8         |
| <b>4-3</b> | <b>Connecting Wires to Push-In Plus Terminal Block</b>          | <b>4-9</b>  |
| 4-3-1      | Terminal Blocks of the Master Unit                              | 4-9         |
| 4-3-2      | Push-In Plus Terminal Block                                     | 4-10        |
| 4-3-3      | Nomenclature of the Push-In Plus Terminal Block and Connections | 4-10        |
| 4-3-4      | Removing Wires from the Push-In Plus Terminal Block             | 4-11        |
| 4-3-5      | Recommended Ferrules and Crimp Tools                            | 4-12        |
| <b>4-4</b> | <b>I/O Wiring of the Master Units</b>                           | <b>4-14</b> |
| 4-4-1      | Power Supply input Wiring                                       | 4-14        |
| 4-4-2      | Transistor Output Wiring  | 4-14        |
| 4-4-3      | Wiring of Error Output  | 4-15        |

# 4-1 Dimensions

This section describes the external dimensions of components of the wireless pushbutton switches system.

## 4-1-1 Master Unit

### Master Unit Device

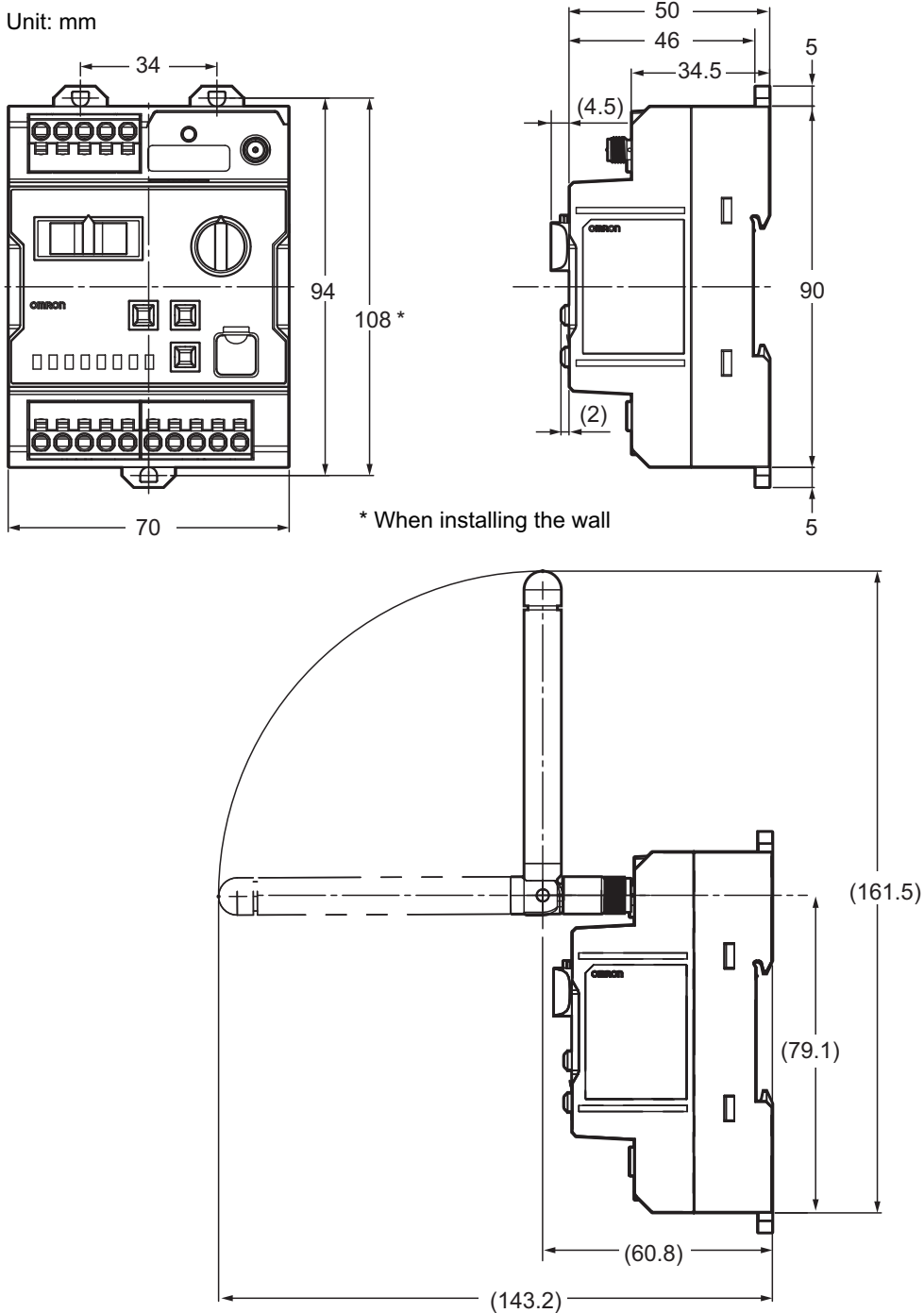



**Option (sold separately)**

- **A2W-AT2.5-WC1 High-sensitivity Magnetic-base Antenna**

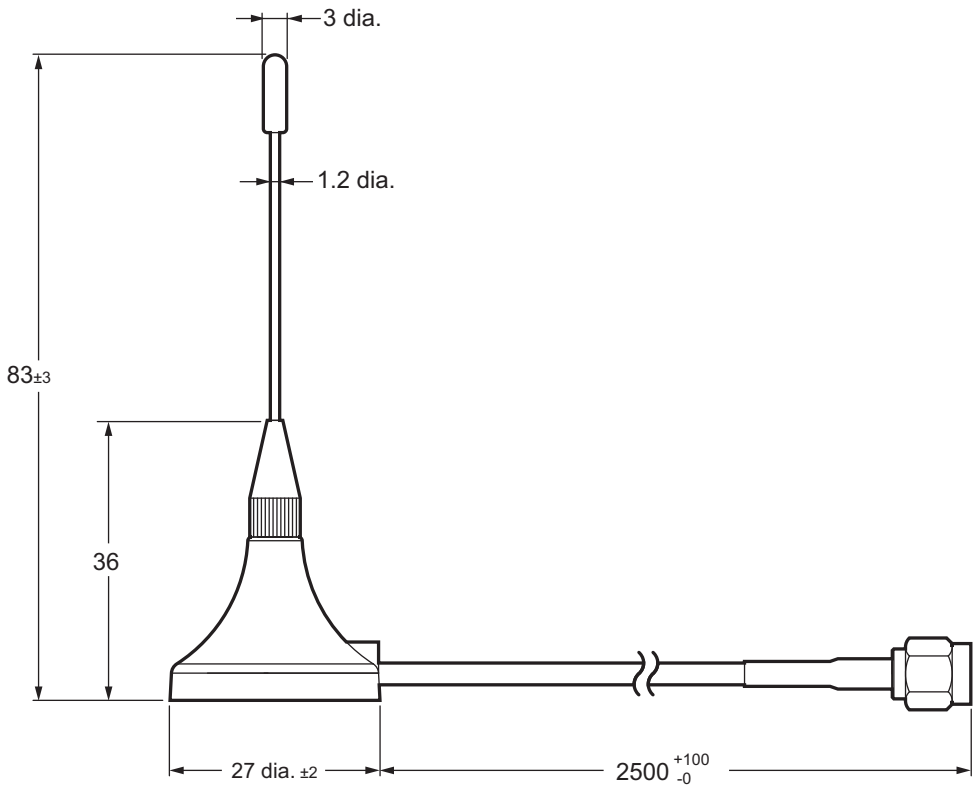

**4-1-2 Slave button**

**Slave button Device**

● **Mushroom A2W-□□-WC1-□□1□□**

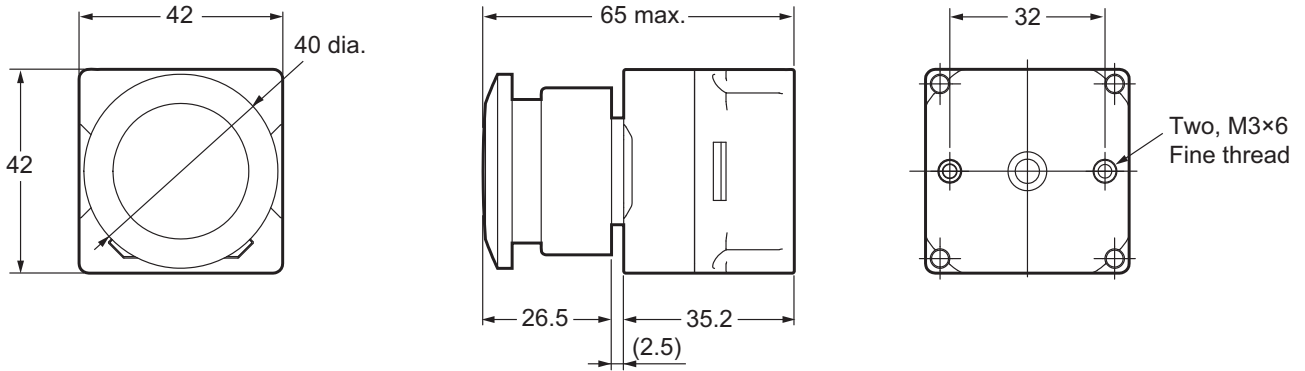

● **Full guard A2W-□□-WC1-□□2□□**

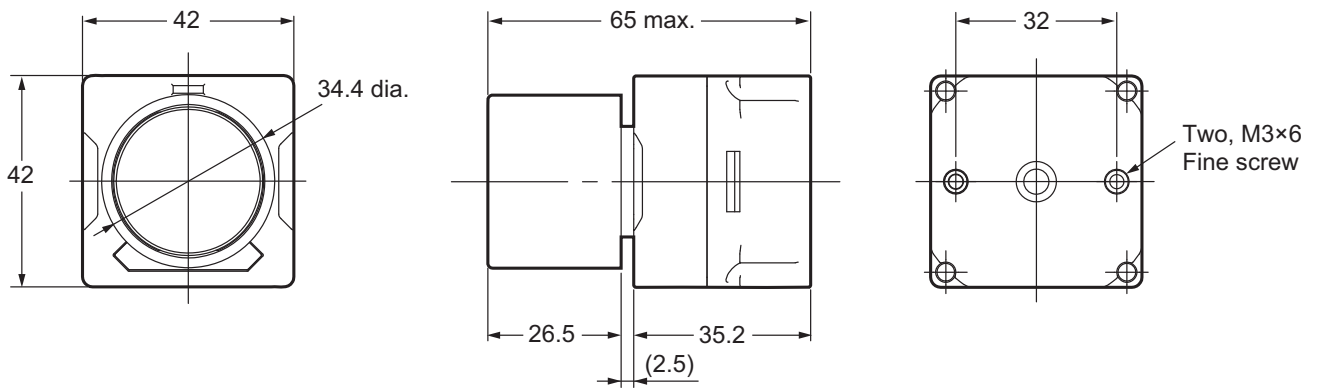

**Accessories (sold separately)**

● **Slave Button Holder A2W-H-WC1**

(One A2W-H-WC1 is bundled when purchasing the Slave button.)

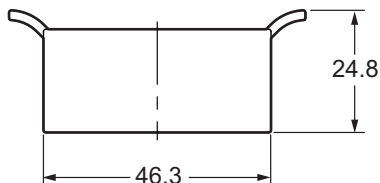
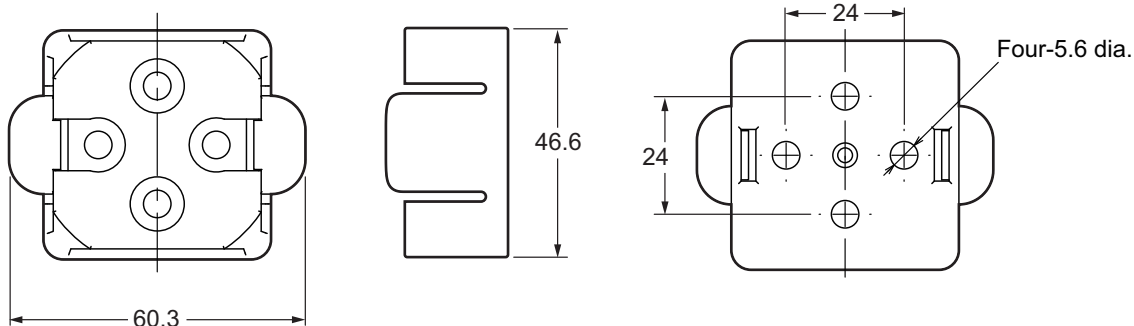

Mounting Hole Dimensions

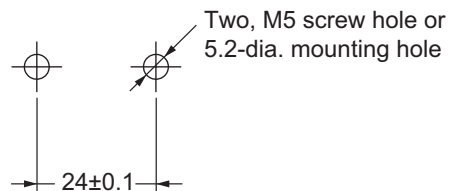

● **Slave Button Strap A2W-S-WC1**

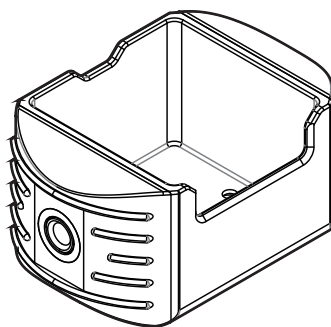
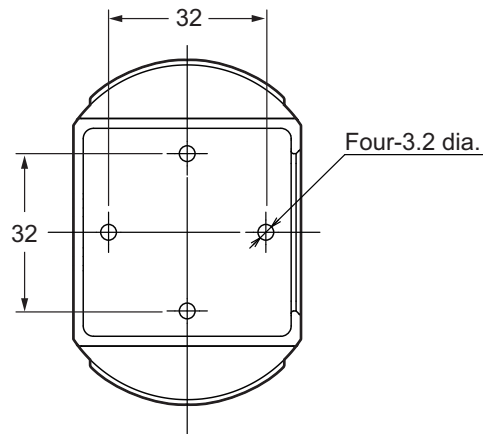

Slave button mounting screws:  
Accessories (2 places)  
Be sure to use the accessory screws.

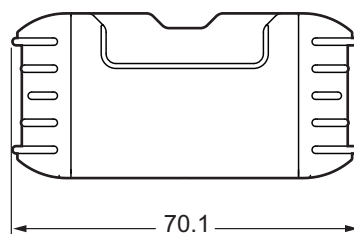
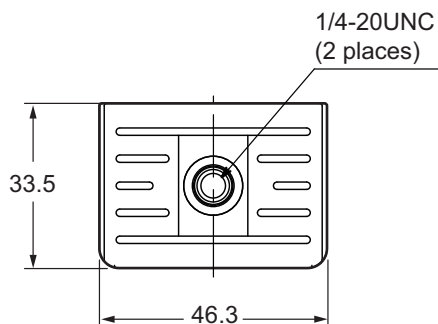

## 4-2 Installing Master Units

This section describes how to install the Master Units.

Mounting on the DIN rail or screw mounting on the wall can be used for installing the Main Units.

### 4-2-1 DIN Rail Installation

Secure each DIN rail inside a control panel with at least three screws.

#### Secure the DIN Rail

- Recommended DIN rail

| Model    | Dimensions | Manufacturer |
|----------|------------|--------------|
| PFP-100N | 1,000 mm   | OMRON        |
| PFP-50N  | 500 mm     |              |

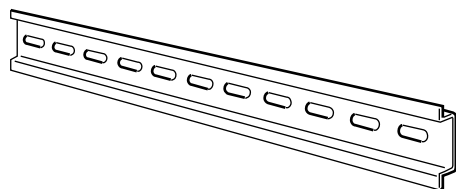

- DIN Rail End Plates PFP-M (2 required)

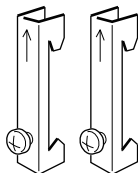

### ● Installation direction

A Master Unit can be installed in any of the following orientations.

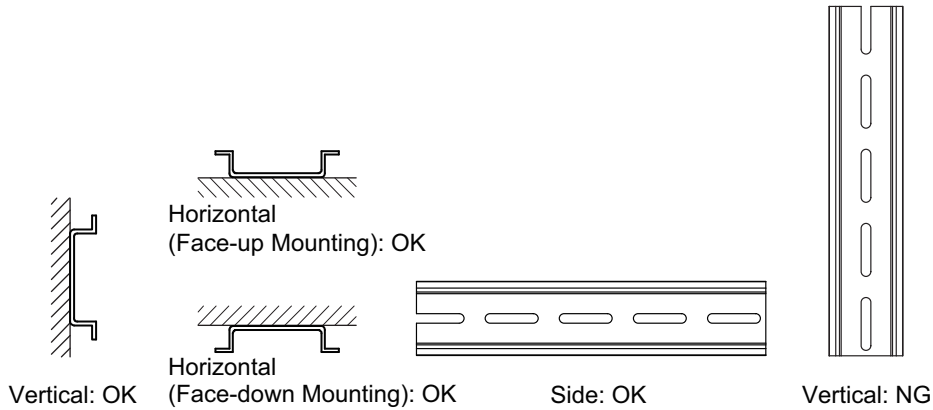

<Face-up Mounting>

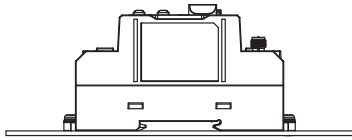

<Standard mounting>

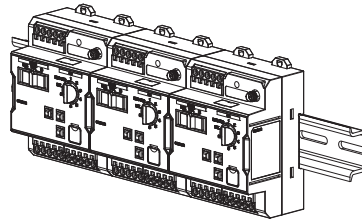

<Face-down Mounting>

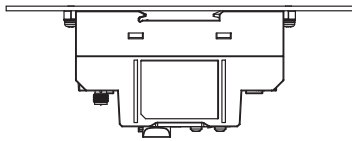

### \* Mounting to DIN Rail

Do not install a product with a pencil-type antenna in a metal panel as it may result in degradation of radio performance.

When installing the Master Unit inside a panel, use a high-sensitivity magnetic-base antenna, and make sure the antenna can be installed outside the panel.

## How to install Master Unit

### ● Installation Method

- (1) Insert the hook on the top of the product into the DIN Rail.
- (2) Press the product until the hook lock into place.

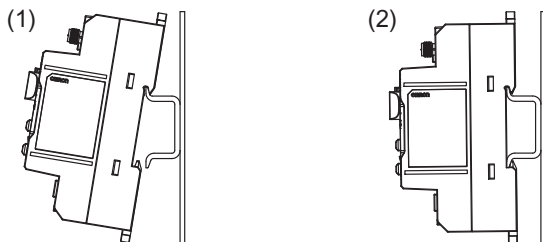

## How to remove Master Unit

Pull down on the hook with a flat-blade screwdriver and lift up on then the Master Unit.

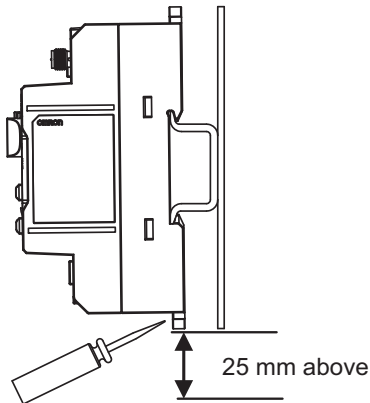

### 4-2-2 Screw Mounting

## How to install Master Unit

- (1) Pull out the three hooks at the back of the product toward the outside until a sound is heard.
- (2) Insert M3 screws in a hole of the hooks to secure.

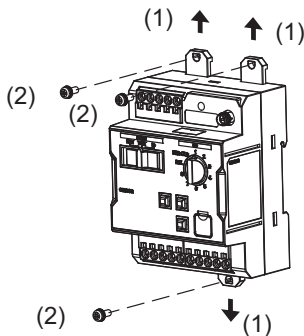

### 4-2-3 Using the Magnetic-base Antenna

High-sensitivity Magnetic-base Antenna (A2W-AT2.5-WC1) of the option (sold separately) should be used when the radio environment is not good, such as when installing Master Unit inside the control panel.

Install the High-sensitivity Magnetic-base Antenna outside the control panel.

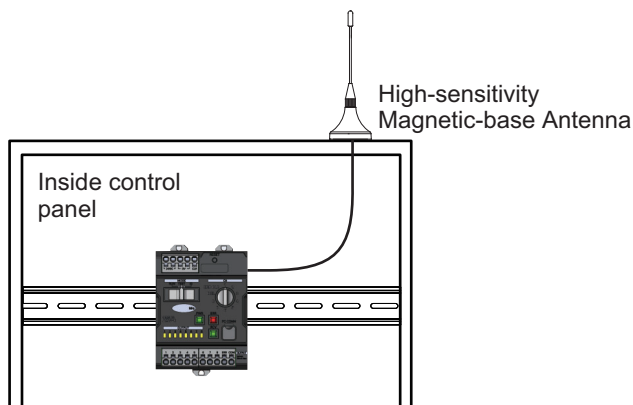

## 4-3 Connecting Wires to Push-In Plus Terminal Block

This section describes how to connect to the push-In Plus terminal block of the Master Unit.



### Precautions for Safe Use

- To prevent wiring materials from smoking or ignition, confirm wire ratings and use the wiring materials given in the following table.

Recommended wires

| Recommended wires  |          |
|--------------------|----------|
| (mm <sup>2</sup> ) | (AWG)    |
| 0.25 to 2.5        | 24 to 14 |

Stripping length

| Recommended Wire Type                    | Ferrules length | Recommended stripping length |                   |
|--|-----------------|------------------------------|-------------------|
|  |                 | Ferrules used                | Ferrules not used |
| 0.25 to 1.5 mm <sup>2</sup> /AWG24 to 16 | 8 mm            | 10 mm                        | 8 mm              |
|  | 10 mm           | 12 mm                        | 10 mm             |
| 2 to 2.5 mm <sup>2</sup> /AWG14          | 10 mm           | 12 mm                        | 10 mm             |

- Do not insert more than one wire into each terminal insertion hole.
- Do not wire anything to the release holes.
- Do not tilt or twist a flat-blade screwdriver while it is inserted into a release hole on the terminal block. The terminal block may be damaged.
- Insert a flat-blade screwdriver into the release holes at an angle. The terminal block may be damaged if you insert the screwdriver straight in.
- Do not push the terminal block with a force exceeding 40 N when inserting wires or when inserting a flat-blade screwdriver in a release hole.
- Do not allow the flat-blade screwdriver to fall out while it is inserted into a release hole.
- Do not bend a wire past its natural bending radius or pull on it with excessive force.

### 4-3-1 Terminal Blocks of the Master Unit

The following all wiring terminals of the wireless pushbutton switch are Push-In Plus terminals.

- Power supply terminal
- Output terminal
- Error output terminal

### 4-3-2 Push-In Plus Terminal Block

| Item                               | Specifications   |
|------------------------------------|--|
| Construction                       | Hands free<br>Front-in front and front-release   |
| Applicable wires                   | Stranded wires, solid wires, or ferrules   |
| Applicable wire size               | 0.25 to 1.5 mm <sup>2</sup> (AWG24 to AWG14)   |
| Wire insertion force               | 8 N max. for AWG20 wire  |
| Screwdriver insertion force        | 15 N max.  |
| Stripping length                   | Refer to the "Stripping length" of "Precautions for Safe Use" in <i>4-3 Connecting Wires to Push-In Plus Terminal Block</i> on page 4-9. |
| Ferrule conductor length           | Refer to the "Stripping length" of "Precautions for Safe Use" in <i>4-3 Connecting Wires to Push-In Plus Terminal Block</i> on page 4-9. |
| Recommended Flat-blade Screwdriver | Refer to the "Recommended Flat-blade Screwdriver" of <i>4-3-5 Recommended Ferrules and Crimp Tools</i> on page 4-12.                     |
| Current capacity                   | 10 A (per pole)  |
| Number of insertions               | 50 times   |
| Recommended ferrules               | Refer to the "Recommended ferrules" of <i>4-3-5 Recommended Ferrules and Crimp Tools</i> on page 4-12.                                   |

### 4-3-3 Nomenclature of the Push-In Plus Terminal Block and Connections

#### Nomenclature of the Terminal Block

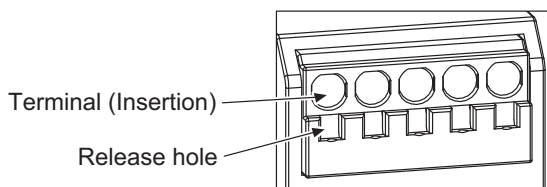

#### Connecting Wires with Ferrules and Solid Wires

Insert the solid wire or ferrule straight into the terminal block until the end strikes the terminal block.

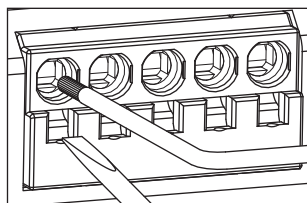

If a wire is difficult to connect because it is too thin, use a flat-blade screwdriver in the same way as when connecting stranded wire.



## Connecting Stranded Wires

Use the following procedure to connect the wires to the terminal block.

- 1** Hold a flat-blade screwdriver at an angle and insert it into the release hole.  
The angle should be between  $10^{\circ}$  and  $15^{\circ}$ .  
If the flat-blade screwdriver is inserted correctly, you will feel the spring in the release hole.
- 2** With the flat-blade screwdriver still inserted into the release hole, insert the wire into the terminal hole until it strikes the terminal block.
- 3** Remove the flat-blade screwdriver from the release hole.

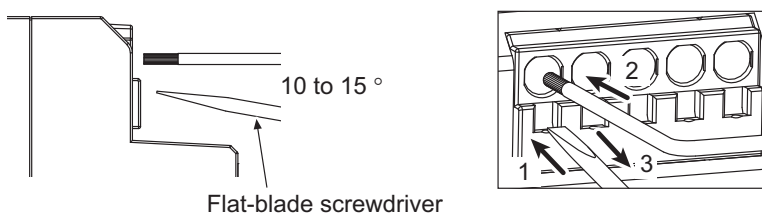

## Checking Connections

- After the insertion, pull gently on the wire to make sure that it will not come off and the wire is securely fastened to the terminal block.
- To prevent short circuits, insert the stripped part of a stranded or solid wire or the conductor part of a ferrule until it is hidden inside the terminal insertion hole.

### 4-3-4 Removing Wires from the Push-In Plus Terminal Block

Use the following procedure to remove wires from the terminal block.

The same method is used to remove stranded wires, solid wires, and ferrules.

- 1** Hold a flat-blade screwdriver at an angle and insert it into the release hole.
- 2** With the flat-blade screwdriver still inserted into the release hole, remove the wire from the terminal insertion hole.
- 3** Remove the flat-blade screwdriver from the release hole.

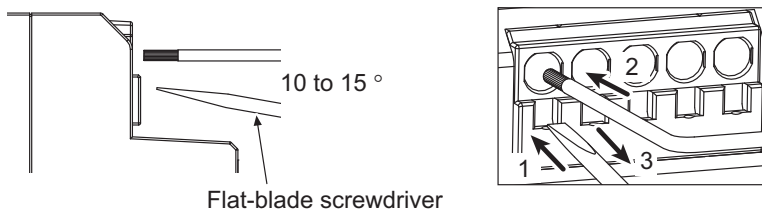

### 4-3-5 Recommended Ferrules and Crimp Tools

#### Recommended ferrules

| Applicable wire        |       | Ferrule Conductor length (mm) | Stripping length (mm) (Ferrules used) | Recommended ferrules                     |                            |                      |
|------------------------|-------|-------------------------------|---------------------------------------|--|----------------------------|----------------------|
| (mm <sup>2</sup> )     | AWG   |                               |                                       | Manufactured by Phoenix Contact          | Manufactured by Weidmuller | Manufactured by Wago |
| 0.25                   | 24    | 8                             | 10                                    | AI 0,25-8                                | H0.25/12                   | FE-0.25-8N-YE        |
|                        |       | 10                            | 12                                    | AI 0,25-10                               | ---                        | ---                  |
| 0.34                   | 22    | 8                             | 10                                    | AI 0,34-8                                | H0.34/12                   | FE-0.34-8N-TQ        |
|                        |       | 10                            | 12                                    | AI 0,34-10                               | ---                        | ---                  |
| 0.5                    | 20    | 8                             | 10                                    | AI 0,5-8                                 | H0.5/14                    | FE-0.5-8N-WH         |
|                        |       | 10                            | 12                                    | AI 0,5-10                                | H0.5/16                    | FE-0.5-10N-WH        |
| 0.75                   | 18    | 8                             | 10                                    | AI 0,75-8                                | H0.75/14                   | FE-0.75-8N-GY        |
|                        |       | 10                            | 12                                    | AI 0,75-10                               | H0.75/16                   | FE-0.75-10N-GY       |
| 1/1.25                 | 18/17 | 8                             | 10                                    | AI 1-8                                   | H1.0/14                    | FE-1.0-8N-RD         |
|                        |       | 10                            | 12                                    | AI 1-10                                  | H1.0/16                    | FE-1.0-10N-RD        |
| 1.25/1.5               | 17/16 | 8                             | 10                                    | AI 1,5-8                                 | H1.5/14                    | FE-1.5-8N-BK         |
|                        |       | 10                            | 12                                    | AI 1,5-10                                | H1.5/16                    | FE-1.5-10N-BK        |
| 2.5                    | 14    | 10                            | 12                                    | AI 2,5-10                                | H2.5/16DS                  | FE-2.5-10N-BU        |
| Recommended crimp tool |       |                               |                                       | CRIMPFOX6<br>CRIMPFOX6T-F<br>CRIMPFOX10S | PZ6 roto                   | Variocrimp4          |

- Note 1. Make sure that the outer diameter of the wire coating is smaller than the inner diameter of the insulation sleeve of the recommended ferrule.
2. Make sure that the ferrule processing dimensions conform to the following figures.

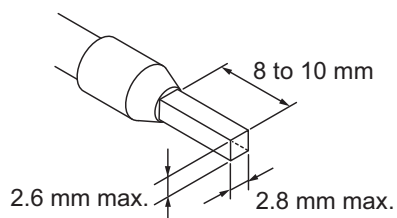

## Recommended Flat-blade Screwdriver

Use a flat-blade screwdriver to connect and remove wires.

Use the following flat-blade screwdriver.

The table below is the manufacturer and format as of December 2015.

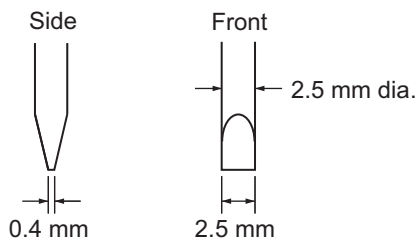

| Model                       | Manufacturer    |
|-----------------------------|-----------------|
| ESD 0,40×2,5                | Wera            |
| SZS 0,4×2,5                 | Phoenix Contact |
| SZF 0-0.4×2.5* <sup>1</sup> |                 |
| 0.4×2.5×75 302              | Wiha            |
| AEF.2,5×75                  | Facom           |
| 210-719                     | Wago            |
| SDI 0.4×2.5×75              | Weidmuller      |

\*1. OMRON's exclusive purchase model XW4Z-00B is available to order as SZF 0-0.4 x 2.5 (manufactured by Phoenix Contact).

## 4-4 I/O Wiring of the Master Units

This section describes how to wire the wireless pushbutton switch Master Unit.

### 4-4-1 Power Supply input Wiring

Power must be supplied to the Master Unit.

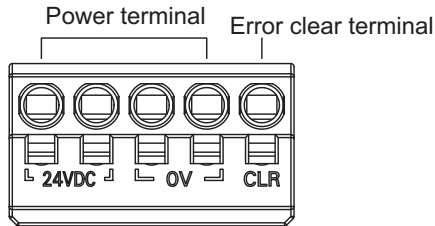

(Upper left part of the Master Unit)

The power input terminal is the push-in Plus terminal.

There are two terminals for 24 VDC, 0 V each. The power line can be connected to either.

### 4-4-2 Transistor Output Wiring

The master unit has 8 transistor outputs corresponding to the Slave button.

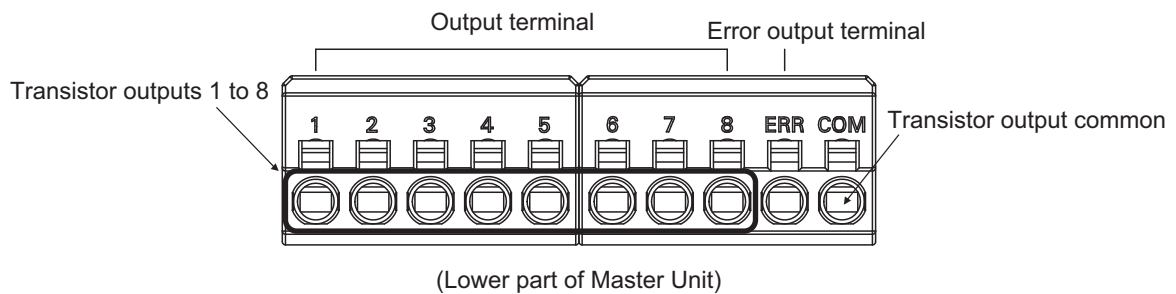

The transistor output terminals are the Push-In Plus terminals.

| Item                                 | Specifications    |
|--------------------------------------|-------------------|
| Supply voltage to the output circuit | 30 VDC max.       |
| Maximum load current                 | 50 mA per point   |
| Leakage current                      | 0.1 mA max.       |
| Residual voltage                     | 2.0 V max.        |
| Output logic                         | One-shot (500 ms) |

### 4-4-3 Wiring of Error Output

The master unit has one output terminal at error.

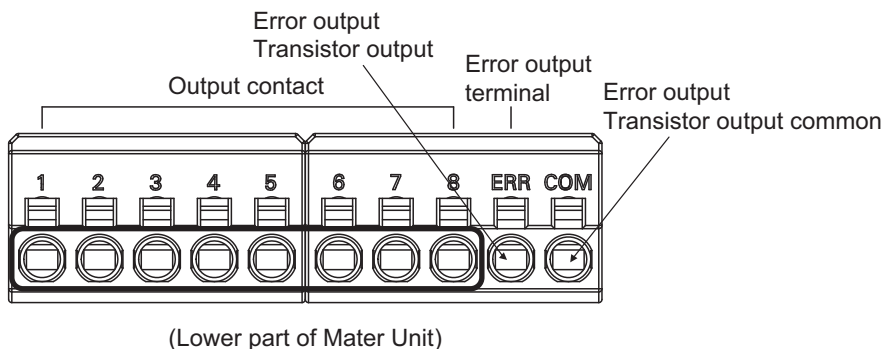

The error output terminal is the Push-In Plus terminal.

| Item                                 | Specifications  |
|--------------------------------------|-----------------|
| Supply voltage to the output circuit | 30 VDC max.     |
| Maximum load current                 | 50 mA per point |
| Leakage current                      | 0.1 mA max.     |
| Residual voltage                     | 2.0 V max.      |

### Error Output Signal

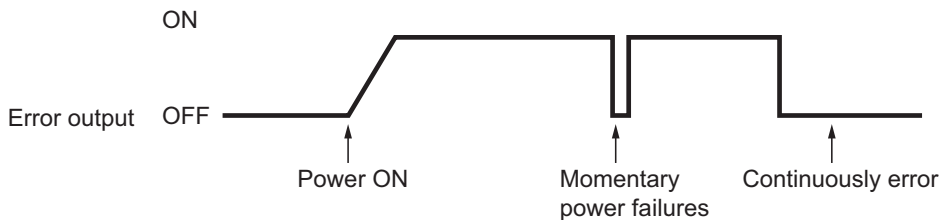

| Status                            | Internal transistor |
|-----------------------------------|---------------------|
| Power is OFF                      | OFF                 |
| Normal operation                  | ON                  |
| Error, or momentary power failure | OFF                 |



# 5

## Registration in the ID Mode

This section describes how to register the Slave buttons to the Master Unit in the wireless pushbutton switches system.

---

|            |   |            |
|------------|---|------------|
| <b>5-1</b> | <b>How to Register Slave Buttons to Master Unit</b> ..... | <b>5-2</b> |
| 5-1-1      | Steps to Register the Slave Buttons .....                 | 5-3        |
| 5-1-2      | How to Delete Slave Buttons .....                         | 5-5        |

## 5-1 How to Register Slave Buttons to Master Unit

---

This section describes how to register/delete the Slave buttons to/from the Master Unit.

In ID mode, you can register Slave buttons to the Master Unit.



### **Precautions for Correct Use**

---

- If you register a Slave button to the Master Unit in an environment where another wireless pushbutton switch system is operating around it, it can be erroneously set. Therefore, when registering a Slave button, perform in an environment where the system of another wireless pushbutton switch is not operated.
  - Register Slave buttons to one Master Unit one by one. Be sure to set the other Master Units to the RUN mode or TEST mode.
- 

If the power of the Master Unit drops due to an instantaneous power failure or the like while registering the Slave button, the setting information may not be stored correctly in the Master Unit's memory. Then, the Master Unit may not work properly at the next startup. When registering, perform it with stable power supply status.



### 5-1-1 Steps to Register the Slave Buttons

Register the Slave button one by one.

Register operation is performed on both Master Unit and Slave buttons.

If you want to register multiple Slave buttons to the same output number of one Master Unit, repeat the operation for a Slave button one by one as shown below.

#### ● Operation Procedure Flowchart

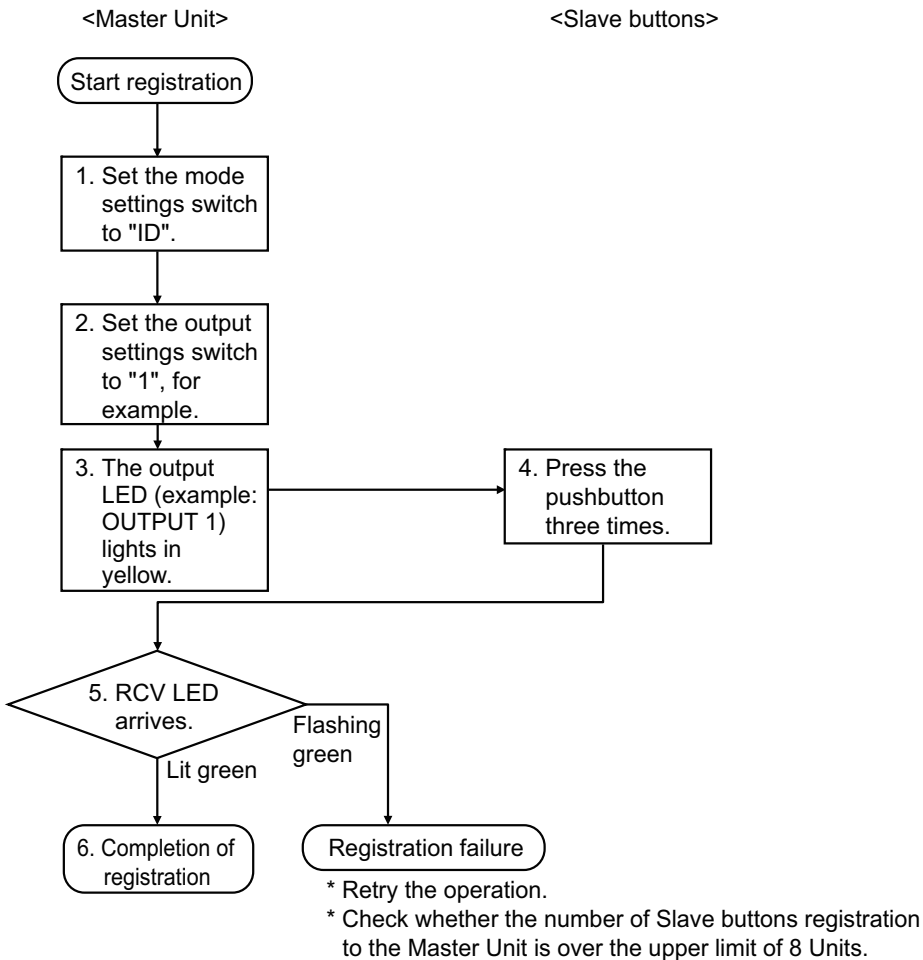

● Procedure

- 1** Set the "mode settings switch" of the Master Unit to "ID" (ID mode).

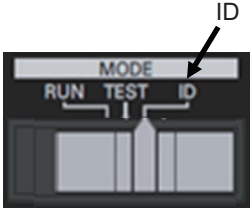

Mode settings switch
- 2** Set the "output settings switch" of the Master Unit to (e.g., 1).



Output settings switch
- 3** The output LED (e.g., OUTPUT 1) of the Master Unit will turn yellow.  
OUTPUT 1 turns yellow.

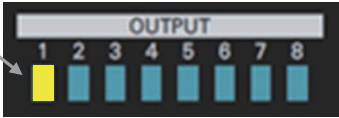

Output LED
- 4** Press the Slave button you want to register 3 successive times within 3 seconds. This assigns the ID of the Slave button to the output number of the Master Unit.

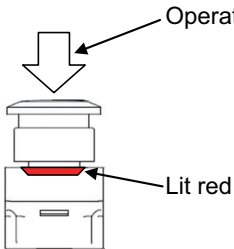

Slave button

Note You can operate it more than three times.
- 5** The RCV LED of the Master Unit will light green for 3 seconds.



RCV LED

Note If registration fails, the Master Unit's RCV LED will flash green for 3 seconds.
- 6** Registration complete.

### 5-1-2 How to Delete Slave Buttons

There are three ways to delete the Slave button as follows.

|   | How to delete Slave buttons   | Note: Whether or not to implement when the Slave button fails |
|---|---|---|
| 1 | Delete all Slave buttons together   | Possible  |
| 2 | Delete a specific Slave button  | Not possible  |
| 3 | Delete all the Slave buttons registered in the specific output number of the Master Unit together | Possible  |

● **Delete all Slave Buttons Together**

Example: When six Slave buttons are assigned to the Master Unit, all the Slave buttons are deleted

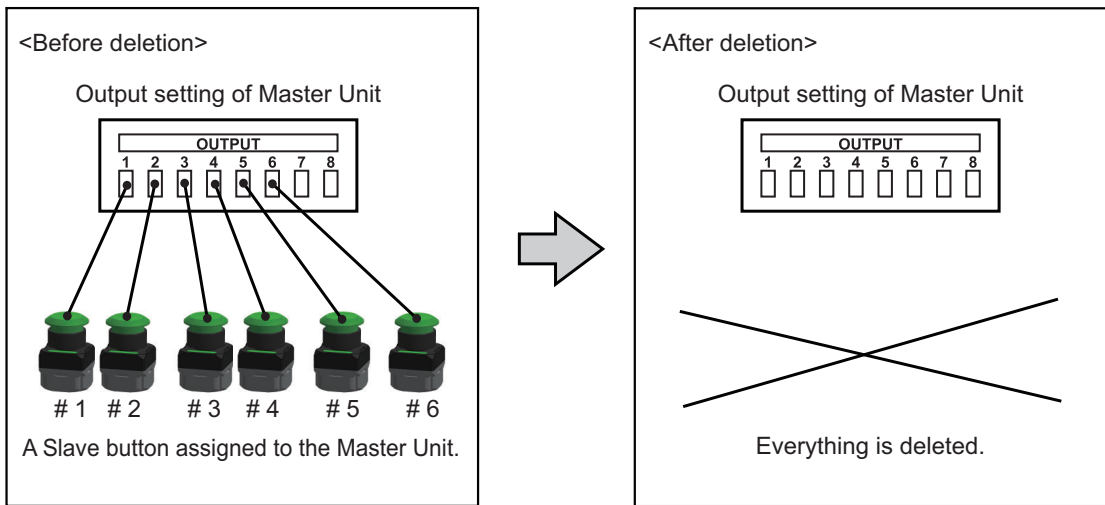

● **Delete a Specific Slave Button**

Example: When Slave button # 1 was assigned to Output No. 1 and 2 of the Master Unit, Slave button # 1 was deleted

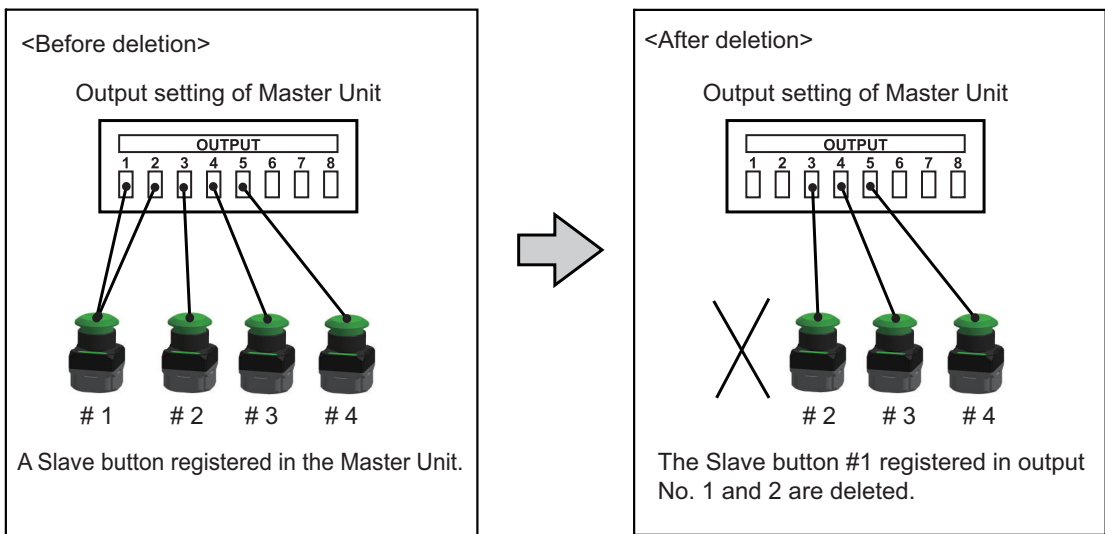

● **Delete All the Slave Buttons Registered in the Specific Output Together**

Example: When the Slave button # 1 and # 2 are assigned to the output No. 1 of the Master Unit, the output No. 1 is deleted

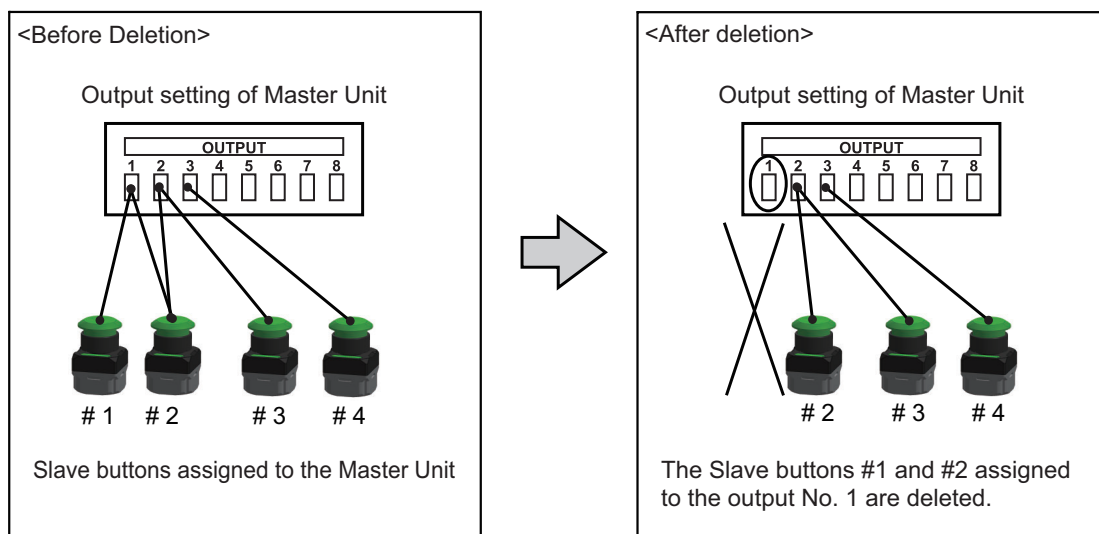

**Delete all Slave Buttons Together**

Delete operation is performed only on the Master Unit side.

● **Operation Procedure Flowchart**

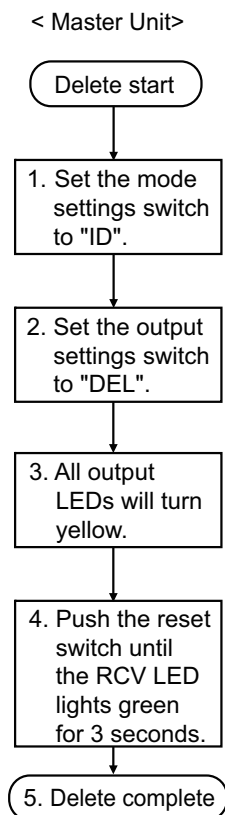

● Procedure

**1** Set the "mode setting switch" of the Master Unit to "ID" (ID mode).

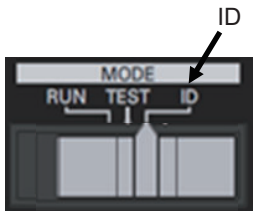

Mode settings switch

**2** Set the "output setting switch" of the Master Unit to "DEL".

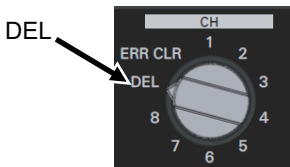

Output settings switch

**3** All the output LEDs of the Master Unit will turn yellow.

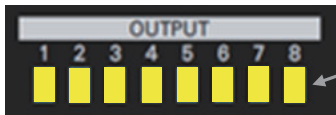

All LEDs turn yellow.

Output LED (OUTPUT 1 to 8)

**4** Press and hold the Master Unit's "Reset Switch" until the RCV LED lights green for 3 seconds.



Reset switch

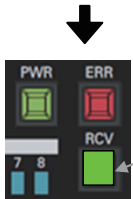

Green lit for 3 seconds

RCV LED

**5** Delete complete.

## Delete a Specific Slave Button

Delete operations are performed on both the Master Unit side and the specific Slave button. When the Slave button to delete is assigned to multiple output numbers of the Master Unit, Slave buttons are deleted from multiple output numbers at once.

### ● Operation Procedure Flowchart

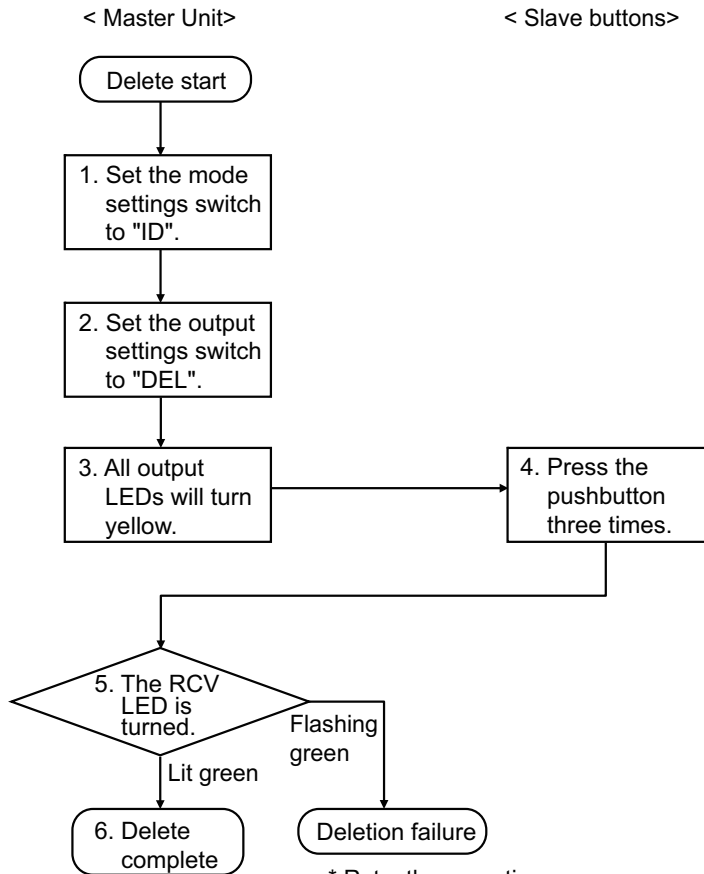

\* Retry the operation.

\* Confirm that the Slave button to be deleted is registered in the Master Unit (it is not originally registered in the Master Unit).

● Procedure

1 Set the "mode settings switch" of the Master Unit to "ID" (ID mode).

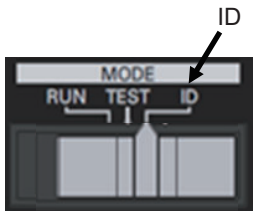

Mode settings switch

2 Set the "output settings switch" of the Master Unit to "DEL".

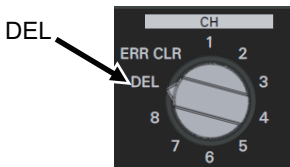

Output settings switch

3 All the output LEDs of the Master Unit will turn yellow.

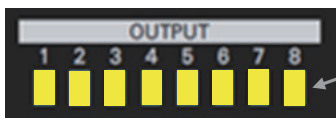

All LEDs turn yellow.

Output LED (OUTPUT 1 to 8)

4 Press the Slave button you want to delete 3 successive times within 3 seconds.

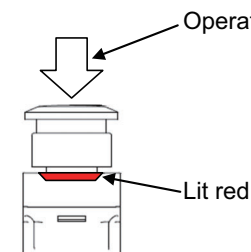

Slave button

Note You can operate it more than three times.

5 The RCV LED of the Master Unit will light green for 3 seconds.



Lit green

RCV LED

6 Delete complete.

## Delete ALL the Slave Buttons Registered to the Specific Output Together

Delete operation is performed only on the Master Unit side.

When multiple Slave buttons are registered in the output No. of the Master Unit to be deleted, multiple Slave buttons are deleted together.

### ● Operation Procedure Flowchart

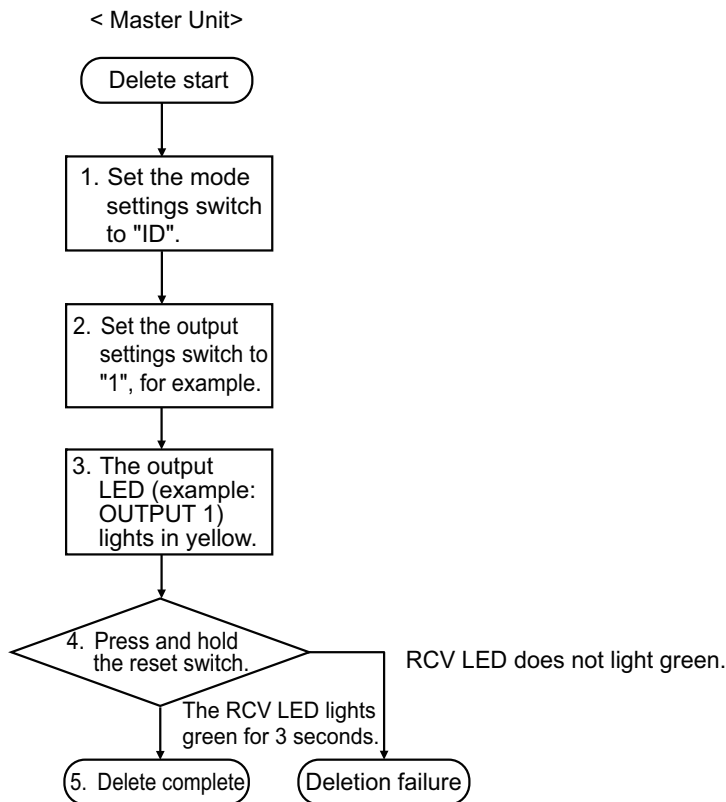

\* Retry the operation

\* Check whether it is registered in the Slave button as the output No. to be deleted (originally, the Slave button is not registered in the output No.).



● Procedure

**1** Set the "mode settings switch" of the Master Unit to "ID" (ID mode).



Mode settings switch

**2** Set the "Output settings switch" of Master Unit to one of the ID "1" to "8" of the Slave button you want to delete.

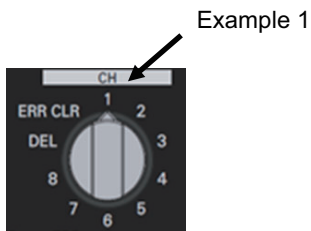

Output settings switch

**3** The output LED (e.g., OUTPUT 1) of the Master Unit will turn yellow.  
OUTPUT 1 turns yellow.

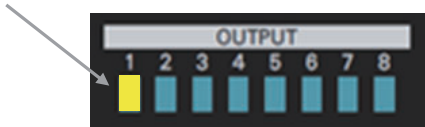

Output LED

**4** Continue to hold the reset switch of the Master Unit.



Reset switch

**5** The RCV LED of the Master Unit will light green for 3 seconds.

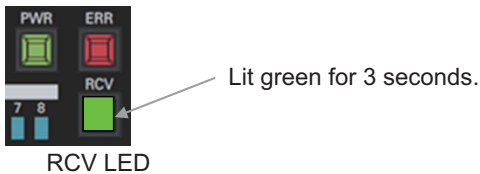

**6** Delete complete.





# Wireless Test in the TEST Mode

This section describes the wireless test execution method of the wireless pushbutton switches system.

---

|            |                      |            |
|------------|----------------------|------------|
| <b>6-1</b> | <b>Wireless Test</b> | <b>6-2</b> |
|------------|----------------------|------------|

# 6-1 Wireless Test

This section describes the wireless test procedure of the wireless pushbutton switches system.

In TEST mode, you can perform a wireless test.

In TEST mode, the Master Unit does not output even when receiving an operation signal from the Slave buttons. TEST mode is used for installation environment test such as reception strength measurement.

Do not execute the wireless test at the same time for multiple Master Units in TEST mode. Be sure to perform the test for each Master Unit. If wireless test for two or more Master Units in TEST mode are executed at the same time, they may be influenced by each other's radio and may not obtain the correct result.

## ● Operation Procedure Flowchart

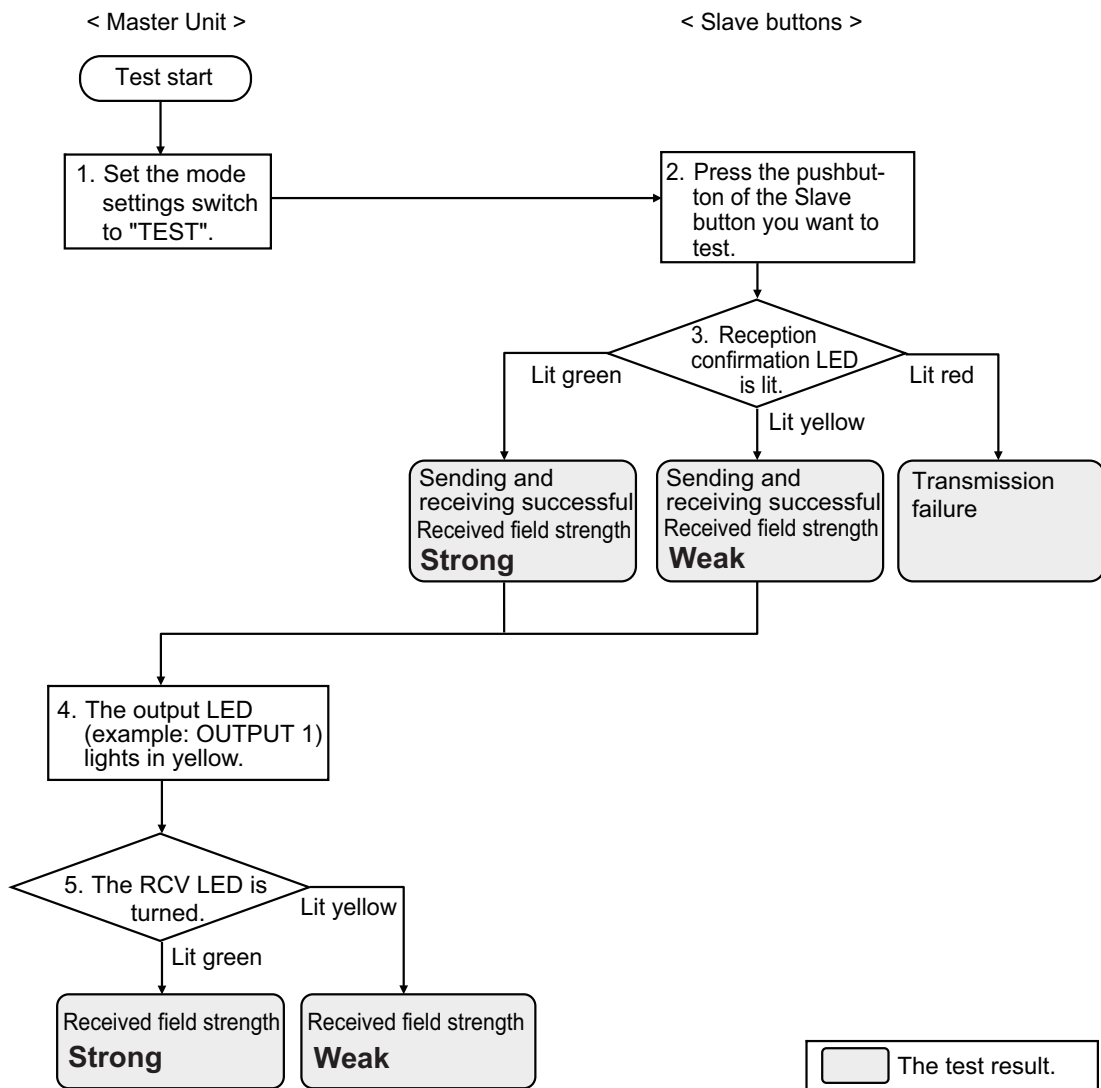

## ● Procedure

- 1** Set the "mode settings switch" of the Master Unit to "TEST" (TEST mode).

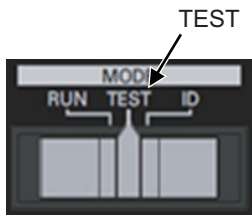

Mode settings switch

- 2** Press the Slave button that you want to test.

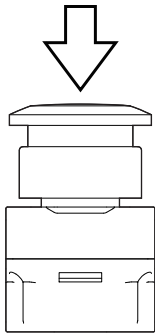

Slave button

- 3** When the Slave button is pressed and if transmission and reception with the Master Unit is successful, the reception confirmation LED of the Slave button will light green.

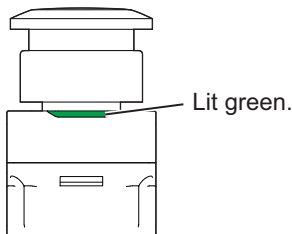

Slave button

Note Yellow lights up when reception sensitivity falls, and red will light when transmission or reception fails.

- 4** The output LED (e.g., OUTPUT 1) of the Master Unit will turn yellow for 0.5 seconds. (The output number 1 of the Master Unit remains OFF.)

OUTPUT 1 turns yellow.

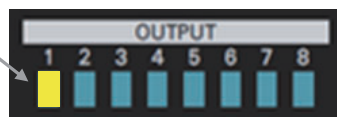

Output LED

- 5** When the reception field Strength is “Strong”, the RCV LED of the Master Unit will light green for 0.5 seconds.  
When the reception field Strength is “Weak”, the RCV LED of the Master Unit will light yellow for 0.5 seconds.



Lit green: Received field strength is "Strong".  
Lit yellow: Received field strength is "Weak".

RCV LED



# Run in the RUN Mode

This section describes how to run the wireless pushbutton switches system.

---

|     |                 |     |
|-----|-----------------|-----|
| 7-1 | Operation ..... | 7-2 |
|-----|-----------------|-----|

# 7-1 Operation

This section describes how to actually operate the wireless pushbutton switches system.

In RUN mode, you can perform actual wireless communications. Use this mode for regular operations.

## ● Operation Procedure Flowchart

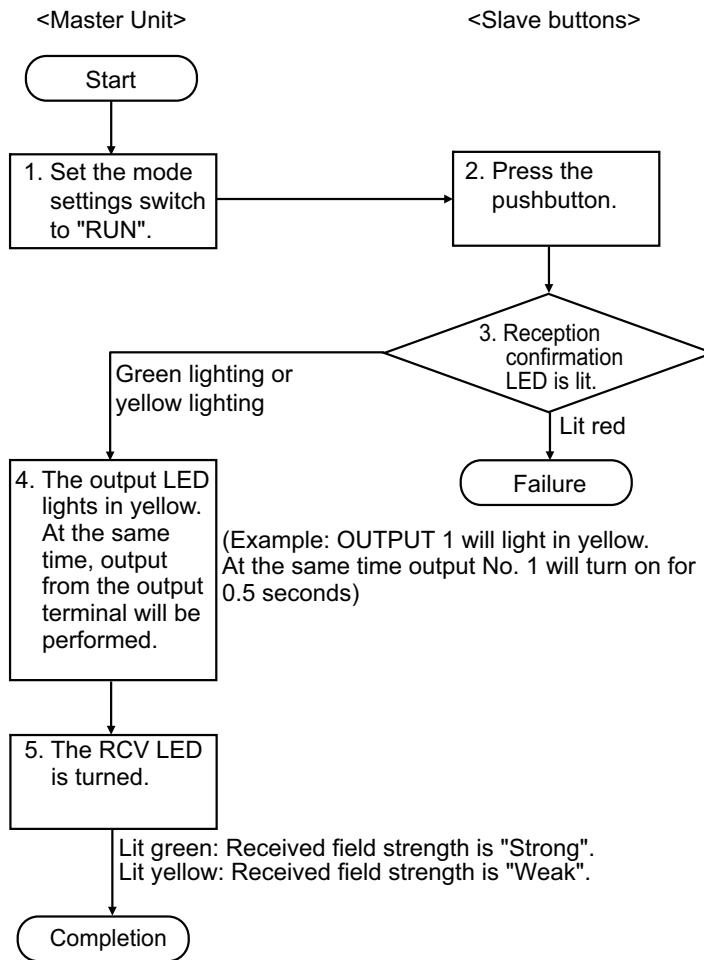



## ● Procedure

- 1** Set the "mode settings switch" of the Master Unit to "RUN" (RUN mode).

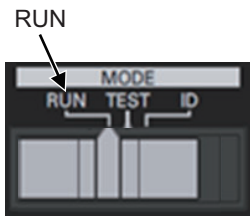

Mode settings switch

- 2** Press the Slave button registered in the Master Unit.

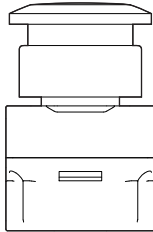

Slave button

- 3** When the Slave button is pressed and if transmission and reception with the Master Unit is successful, the reception confirmation LED of the Slave button will light green.

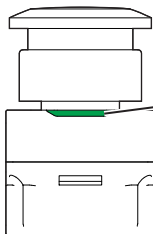

Lit green.

Slave button

Note Yellow lights up when reception sensitivity falls, and red will light when transmission or reception fails.

- 4** The output LED (e.g., OUTPUT 1) of the Master Unit will turn yellow for 0.5 seconds. (The output of the Master Unit turns ON for 0.5 seconds and returns to OFF.)

OUTPUT 1 turns yellow.

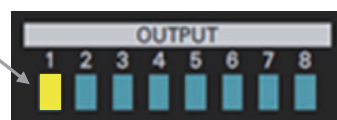

Output LED

- 5** When the reception field Strength is “Strong”, the RCV LED of the Master Unit will light green for 0.5 seconds.  
When the reception field Strength is “Weak”, the RCV LED of the Master Unit will light yellow for 0.5 seconds.



RCV LED

# 8

## Trouble Shooting

This section describes troubleshooting when using the wireless pushbutton switches system.

---

|            |  |            |
|------------|--|------------|
| <b>8-1</b> | <b>Trouble Situations and How to Implement Countermeasures</b> . . . . . | <b>8-2</b> |
| 8-1-1      | Troubles at Installation or Operation . . . . .                          | 8-2        |
| 8-1-2      | LED Indication When Trouble Occurs . . . . .                             | 8-4        |
| <b>8-2</b> | <b>Master Unit Error</b> . . . . .                                       | <b>8-5</b> |
| 8-2-1      | Error Status of the Master Unit . . . . .                                | 8-5        |
| 8-2-2      | How to Reset the Error of Master Unit . . . . .                          | 8-5        |
| 8-2-3      | How to Return Master Unit to Factory Setting . . . . .                   | 8-6        |
| <b>8-3</b> | <b>Replacing Master Unit</b> . . . . .                                   | <b>8-7</b> |
| 8-3-1      | How to Replace Master Unit . . . . .                                     | 8-7        |

## 8-1 Trouble Situations and How to Implement Countermeasures

This section describes trouble situations of the wireless pushbutton switches system and how to implement countermeasures.

### 8-1-1 Troubles at Installation or Operation

| Situation  | Possible cause  | Troubleshooting methods  |
|--|---|--|
| Master Unit's power is not turned ON.                                  | The power supply terminal of the Master Unit is not connected properly.               | Correctly connect again.   |
|  | 24 VDC power is not supplied.   | Connect another 24 VDC supplied device instead of the Master Unit and check whether 24 VDC is supplied. If 24 VDC is supplied, the repair or replacement of the Master Unit is needed. |
| The Master Unit can not receive signals from all the Slave buttons.    | The Master Unit is not correctly connected to the equipment to be controlled.         | Correctly connect again.   |
|  | The antenna of Master Unit is loose.  | Tighten again so that there is no looseness.   |
| The Master Unit can not receive a signal from a specific Slave button. | The ID of the Slave button used for Master Unit is not registered.                    | Register the ID of the Slave button to be used in the Master Unit.   |
|  | The operating frequency of the Slave button is different from one of the Master Unit. | Make the same between the Master Unit and the Slave buttons at the radio frequency displayed on the Master Unit device.  |
|  | Signal is not being transmitted from the Slave button.                                | Confirm that the reception confirmation LED lights after operating the Slave button. If it does not light up, replacement is necessary as the Slave button has failed.                 |
| Wireless communications are interrupted.                               | An object blocking radio waves was placed on the communications path.                 | <ul style="list-style-type: none"> <li>• Move the blocking object after obtaining permission.</li> <li>• Move the installation location of Master Unit and Slave button.</li> </ul>    |
|  | A device that generates noise is nearby.  | Keep the Master Unit and Slave button away from the noise source by about 1 m.   |
| Radio waves are weak.<br>(Yellow LED always lit)                       | A Master Unit or Slave button is installed on the floor.                              | Install the Master Unit and Slave buttons at a relatively high position (about 1.5 m high).  |
|  | There are radio wave obstacles.   | Keep the Master Unit and Slave buttons away from radio wave obstacles about 1 m away   |
|  | The antenna is not oriented properly.   | Adjust the orientation of the antenna and secure it firmly.  |

| Situation   | Possible cause   | Troubleshooting methods   |
|---|--|---|
| It is in an installation environment where radio waves hardly reach.                                    | It is installed in a building whose entire wall is covered with a metal plate.                                 | In operating environments where radio wave obstacles can not be avoided, consider the communications route from the ceiling or from the window. |
|   | There is a steel shelf between Master Unit and Slave button, or it is installed on a floor where people crowd. |   |
| Despite the fact that the Master Unit is receiving a signal, the red LED on the Slave button lights up. | Temporary radio wave obstruction blocked communication route.  | In operating environments where radio wave obstacles can not be avoided, consider the communications route from the ceiling or from the window. |
|   | Equipment that generates noise intermittently is nearby.   | Keep the Master Unit and Slave buttons away from the noise source by about 1 m.   |
| The Master Unit's power supply is turned ON again, but it does not operate normally.                    | The time from turning OFF the power to turning it ON is short.   | To turn ON the power again after turning OFF the power, wait for 30 seconds or more before turning it ON.                                       |

## 8-1-2 LED Indication When Trouble Occurs

### Master Unit

| PWR lighting state         |               | Status  | Troubleshooting methods  |
|----------------------------|---------------|---|--|
| Not lit                    |               | Power is not supplied to Master Unit.   | Refer to the <i>Master Unit's power is not turned ON.</i> on page 8-2 in 8-1-1 <i>Troubles at Installation or Operation</i> on page 8-2.   |
| RCV lighting state         |               | Status  | Troubleshooting methods  |
| Lit yellow after reception |               | The reception is successful, but the radio field strength is weak.              | Refer to the <i>Radio waves are weak.</i> on page 8-2 or <i>It is in an installation environment where radio waves hardly reach.</i> on page 8-3 in the 8-1-1 <i>Troubles at Installation or Operation</i> on page 8-2.  |
| ERR lighting condition     | RCV lit state | Status  | Troubleshooting methods  |
| Lit                        | Not lit       | CPU initialization error at startup.  | Turn ON the power again.<br>If not improved, repair or replacement is necessary.   |
|                            | Lit green     | An error occurred writing or reading the setting data saved in the Master Unit. | Turn ON the power again.<br>If not improved, repair or replacement is necessary.   |
|                            | Lit yellow    | Data error related to wireless communications has occurred.                     | Perform software reset.<br>For the software reset method, refer to 8-2-2 <i>How to Reset the Error of Master Unit</i> on page 8-5.<br>If it is not improved, it is necessary to initialize the setting information, repair or replace the setting information. |

### Slave button

| Lit state                  | Status  | Troubleshooting methods   |
|----------------------------|---|---|
| Do not lit after operation | No signal is being sent from Slave button.  | Replacement is required.  |
| Lit red after operation    | The Slave button failed to receive the reception confirmation signal from the Master Unit.            | Refer to <i>The Master Unit can not receive signals from all the Slave buttons.</i> on page 8-2, <i>The Master Unit can not receive a signal from a specific Slave button.</i> on page 8-2, <i>Radio waves are weak.</i> on page 8-2, or <i>It is in an installation environment where radio waves hardly reach.</i> on page 8-3 in the 8-1-1 <i>Troubles at Installation or Operation</i> on page 8-2. |
| Lit yellow after operation | The Slave button is successful in communicating with the Master Unit, but the field strength is weak. | Refer to the <i>Radio waves are weak.</i> on page 8-2 or <i>It is in an installation environment where radio waves hardly reach.</i> on page 8-3 in the 8-1-1 <i>Troubles at Installation or Operation</i> on page 8-2.   |

## 8-2 Master Unit Error

This section describes the status of the Master Unit error occurrence and how to Implement counter-measures.

### 8-2-1 Error Status of the Master Unit

If an error occurs in the Master Unit, an error signal is output from the error output terminals. At the same time, an error message will be displayed.

#### Error Output of the Master Unit

Refer to the 4-4-3 *Wiring of Error Output* on page 4-15.

#### Master Unit error Indication

| Error LED (ERR) | Received field strength monitor (RCV) | Meaning  |
|-----------------|---------------------------------------|--|
| Lit red         | Lit green                             | Master Unit setting data error   |
|                 | Lit yellow                            | Error in the most important function (wireless received, registration/verification, or output) |
|                 | All LEDs are not lit.                 | Fault in CPU initialization processing at startup  |

### 8-2-2 How to Reset the Error of Master Unit

Error reset can be executed only when ERR is lit in red and RCV is lit in yellow in the Master Unit's error display.

There are two following ways to reset an error.

- Reset operation
- Error clear input

#### Reset Operation

- 1 Set the "output settings switch" of the Master Unit to "ERR CLR".



Output settings switch

- 2 Press the "reset switch" of Master Unit.



Reset switch

- 3 The error is reset.

## Error Clear Input

- 1 Make short the Master Unit error clear terminal to 0 V.

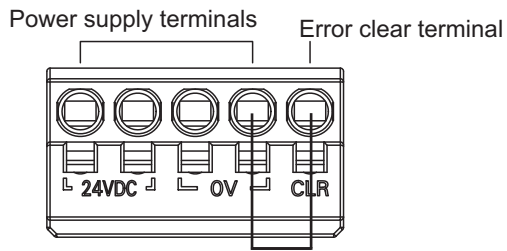

(Upper left part of Master Unit)

The voltage between the error clear terminal and 0 V must be 15 VDC or less to reset the error. The error clear terminal and 0 V are the Push-In Plus terminals.

- 2 The error is reset.

### 8-2-3 How to Return Master Unit to Factory Setting

The Master Unit can be restored to the factory setting by the following method.

- 1 Turn OFF the power supply to the Master Unit.
- 2 With the reset button pressed, Turn ON power to the Master Unit again.
- 3 The setting information is initialized and it returns to the factory setting.



## 8-3 Replacing Master Unit

This section describes how to replace the Master Unit of the wireless pushbutton switch.

### 8-3-1 How to Replace Master Unit

- 1** Make a note of the current Master Unit status.  
Number of Slave buttons, ID of Slave button, wiring of external output, etc.
- 2** Remove all Master Unit wiring.  
Refer to the *4-3-4 Removing Wires from the Push-In Plus Terminal Block* on page 4-11.
- 3** Exchange Master Unit.  
Refer to the *4-2 Installing Master Units* on page 4-6.
- 4** Connect the wiring removed in 2.  
Refer to the *4-3-3 Nomenclature of the Push-In Plus Terminal Block and Connections* on page 4-10 and *4-4 I/O Wiring of the Master Units* on page 4-14.
- 5** Delete all setting of Slave button registered in Master Unit.  
Refer to the *5-1-2 How to Delete Slave Buttons* on page 5-5.
- 6** Register Slave buttons in the Master Unit.  
Refer to the *5-1-1 Steps to Register the Slave Buttons* on page 5-3.
- 7** Test wireless communications.  
Refer to the *6-1 Wireless Test* on page 6-2.

**Note** Unintended communications with other systems may occur after replacing the Master Unit. Therefore, delete all registration of Slave button in the Master Unit once. Then register the Slave buttons again. After that, make sure to execute the communications test before use.



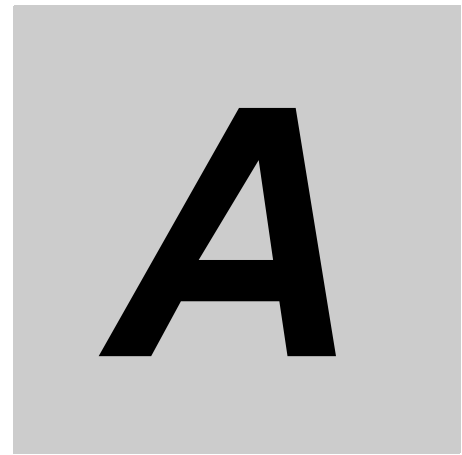

# Appendix

---

---

|  |     |
|--|-----|
| A-1 Slave Button Registration Management Sheet ..... | A-2 |
|--|-----|

# A-1 Slave Button Registration Management Sheet

Use this sheet to record the Slave buttons to be registered in the Master Unit.

Copy the next page.

<Entry example>

● Master Unit #: \_\_\_\_\_ Name of equipment etc.: \_\_\_\_\_

Date: \_\_\_\_\_ Month: \_\_\_\_\_ Year: \_\_\_\_\_ Organization: \_\_\_\_\_ Name: \_\_\_\_\_

| Slave button |   |     | Master Unit Output Number |   |   |   |   |   |   |   |
|--------------|---|-----|---------------------------|---|---|---|---|---|---|---|
|              | Name  | ID  | 1                         | 2 | 3 | 4 | 5 | 6 | 7 | 8 |
| 1            | Line A completion switch                      | 100 | ✓                         | ✓ |   |   |   |   |   |   |
| 2            | Line B completion switch                      | 101 |                           |   | ✓ | ✓ |   |   |   |   |
| 3            | Line C completion switch                      | 102 |                           |   |   |   | ✓ |   |   |   |
| 4            | Call switch                                   | 103 |                           |   |   |   |   | ✓ |   |   |
| 5            | Switch for instructing replenishment of parts | 104 |                           |   |   |   |   |   | ✓ |   |
| 6            |   |     |                           |   |   |   |   |   |   |   |
| 7            |   |     |                           |   |   |   |   |   |   |   |
| 8            |   |     |                           |   |   |   |   |   |   |   |
| (Remarks)    |   |     |                           |   |   |   |   |   |   |   |

For the output number of Master Unit, put a check mark in the column of the registered Slave button number. Also, to confirm the slave button, enter the ID described next to the slave button body.

● Master Unit #: \_\_\_\_\_ Name of equipment etc.: \_\_\_\_\_  
 Date:    Month:    Year:    Organization:    Name: \_\_\_\_\_

| Slave button |      |    | Master Unit Output Number |   |   |   |   |   |   |   |
|--------------|------|----|---------------------------|---|---|---|---|---|---|---|
|              | Name | ID | 1                         | 2 | 3 | 4 | 5 | 6 | 7 | 8 |
| 1            |      |    |                           |   |   |   |   |   |   |   |
| 2            |      |    |                           |   |   |   |   |   |   |   |
| 3            |      |    |                           |   |   |   |   |   |   |   |
| 4            |      |    |                           |   |   |   |   |   |   |   |
| 5            |      |    |                           |   |   |   |   |   |   |   |
| 6            |      |    |                           |   |   |   |   |   |   |   |
| 7            |      |    |                           |   |   |   |   |   |   |   |
| 8            |      |    |                           |   |   |   |   |   |   |   |
| (Remarks)    |      |    |                           |   |   |   |   |   |   |   |

● Master Unit #: \_\_\_\_\_ Name of equipment etc.: \_\_\_\_\_  
 Date:    Month:    Year:    Organization:    Name: \_\_\_\_\_

| Slave button |      |    | Master Unit Output Number |   |   |   |   |   |   |   |
|--------------|------|----|---------------------------|---|---|---|---|---|---|---|
|              | Name | ID | 1                         | 2 | 3 | 4 | 5 | 6 | 7 | 8 |
| 1            |      |    |                           |   |   |   |   |   |   |   |
| 2            |      |    |                           |   |   |   |   |   |   |   |
| 3            |      |    |                           |   |   |   |   |   |   |   |
| 4            |      |    |                           |   |   |   |   |   |   |   |
| 5            |      |    |                           |   |   |   |   |   |   |   |
| 6            |      |    |                           |   |   |   |   |   |   |   |
| 7            |      |    |                           |   |   |   |   |   |   |   |
| 8            |      |    |                           |   |   |   |   |   |   |   |
| (Remarks)    |      |    |                           |   |   |   |   |   |   |   |

● Master Unit #: \_\_\_\_\_ Name of equipment etc.: \_\_\_\_\_  
 Date:    Month:    Year:    Organization:    Name: \_\_\_\_\_

| Slave button |      |    | Master Unit Output Number |   |   |   |   |   |   |   |
|--------------|------|----|---------------------------|---|---|---|---|---|---|---|
|              | Name | ID | 1                         | 2 | 3 | 4 | 5 | 6 | 7 | 8 |
| 1            |      |    |                           |   |   |   |   |   |   |   |
| 2            |      |    |                           |   |   |   |   |   |   |   |
| 3            |      |    |                           |   |   |   |   |   |   |   |
| 4            |      |    |                           |   |   |   |   |   |   |   |
| 5            |      |    |                           |   |   |   |   |   |   |   |
| 6            |      |    |                           |   |   |   |   |   |   |   |
| 7            |      |    |                           |   |   |   |   |   |   |   |
| 8            |      |    |                           |   |   |   |   |   |   |   |
| (Remarks)    |      |    |                           |   |   |   |   |   |   |   |

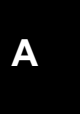





**OMRON Corporation Industrial Automation Company**  
Kyoto, JAPAN

Contact: [www.ia.omron.com](http://www.ia.omron.com)

**Regional Headquarters**

**OMRON EUROPE B.V.**

Wegalaan 67-69, 2132 JD Hoofddorp  
The Netherlands  
Tel: (31)2356-81-300/Fax: (31)2356-81-388

**OMRON ELECTRONICS LLC**

2895 Greenspoint Parkway, Suite 200  
Hoffman Estates, IL 60169 U.S.A.  
Tel: (1) 847-843-7900/Fax: (1) 847-843-7787

**OMRON ASIA PACIFIC PTE. LTD.**

No. 438A Alexandra Road # 05-05/08 (Lobby 2),  
Alexandra Technopark,  
Singapore 119967  
Tel: (65) 6835-3011/Fax: (65) 6835-2711

**OMRON (CHINA) CO., LTD.**

Room 2211, Bank of China Tower,  
200 Yin Cheng Zhong Road,  
PuDong New Area, Shanghai, 200120, China  
Tel: (86) 21-5037-2222/Fax: (86) 21-5037-2200

**Authorized Distributor:**

© OMRON Corporation 2017 All Rights Reserved.  
In the interest of product improvement,  
specifications are subject to change without notice.

**Cat. No. A265-E1-01**

1217