

CLASS 2 TRANSFORMERS AND FAN CENTERS		86 – 90
Description	Model(s)	Page(s)
Class 2 Transformers	90-T	86
Class 2 Transformers Replacement Guide.....	87
Class 2 Transformers	S82/ S84	88
Fan Control Center	90-112 / 90-113 / 90-118E / 90-130 / 90-340	89
Blower Relay / Relay Transformer.....	8A04 / 8A05	90

RELAYS / CONTACTORS		91 – 99
Description	Model(s)	Page(s)
2 Pole Switching Relays	90-340 Thru 90-342	91
1 Pole	94-388 Thru 94-396	92
2 Pole	90-244 Thru 90-249	93
3 Pole	90-160 Thru 90-172	94
3 Pole Heavy Duty	92-459 Thru 92-472	95
Potential Relays.....	90-63 Thru 90-71	96
Potential Relay Cross Reference	97
Enclosed Relays.....	90-290Q Thru 90-295Q	98
Heavy Duty Enclosed Relays	90-360 Thru 90-486	99

DC POWER (CONTACTORS)		100 – 101
Description	Model(s)	Page(s)
DC Power Contactors (SPNO)	Type 70 / Type 120	100
DC Power Contactors (SPNO/SPDT).....	Type 124 / Type 586	101

90-T40S1 THRU 90-T75C3 24 VOLT SECONDARY CLASS 2 TRANSFORMERS ENERGY LIMITING

For Industrial, Heating and Air Conditioning Controls Applications



90-T40F1

FEATURES

- Color coded primary leads.
- Multi-mount styles available.

SPECIFICATIONS

Agency U.L. file number  E33334

MULTI-MOUNT (CLOSED CONSTRUCTION) UNIVERSAL MOUNTING WITH PLATE

Model Number	Mars Part No.	Jard Part No.	VA	Hz	Primary	Connections	Sec.	Connections
90-T40M1	50302	4011M	40	60	120V	Leads	24V	Leads
90-T40M2	50303	4021M	40	50 / 60	208 / 240V	Leads	24V	Leads
90-T40M3	50304	4031M	40	60	120 / 208 / 240V	Leads	24V	Leads

FOOT-MOUNT (OPEN CONSTRUCTION)

Model Number	Mars Part No.	Jard Part No.	VA	Hz	Primary	Connections	Sec.	Connections
90-T40F1	50352	4011F	40	60	120V	Leads	24V	Leads
90-T40F2	50353	4021F	40	50 / 60	208 / 240V	Leads	24V	Leads
90-T40F3	50354	4031F	40	60	120 / 208 / 240V	Leads	24V	Leads
90-T50F3	-	5031F	50	60	120 / 208 / 240V	Leads	24V	Leads

FOOT-MOUNT (MANUAL RESET, OPEN CONSTRUCTION)

Model Number	Mars Part No.	Jard Part No.	VA	Hz	Primary	Connections	Sec.	Connections
90-T50C3	50327	5041C	50	50 / 60	120 / 208 / 240V	Leads	24V	Leads
90-T60C3	50327	6041C	60	50 / 60	120 / 208 / 240V	Leads	24V	Leads
90-T75C3	50321	7541C	75	50 / 60	120 / 208 / 240V	Leads	24V	Leads
90-T100C1	-	-	100	60	120V	Leads	25V	Leads



90-T75C3

TRANSFORMER LEAD COLOR CODING

Primary Side				Secondary Side	
Common	120V	208V	240V	Common	24V
* Black	White	Red	Orange	Blue	Yellow

* Black is common with respect to the transformer winding, not the external circuit.

Model Number	Suggested Replacement	Model Number	Suggested Replacement	Model Number	Suggested Replacement
3TZ66	90-T40M1	90-4021F	90-T40F1	AT72D1196	90-T40M2
3TZ67	90-T40F3	90-4031F	90-T40F3	AT72D1204	90-T40M1
3TZ68	90-T40M3	90-5031F	90-T50F3	AT72D1246	90-T40M1
3TZ69	90-T60C3	90-6041C	90-T60C3	AT72D1683	90-T40M1
3TZ70	90-T75C3	90-7541C	90-T75C3	AT72D1691	90-T40M2
4011F	90-T40F1	90-T40F1	90-T40F1	AT87A1049	90-T50F3
4021F	90-T40F2	90-T40F2	90-T40F2	AT87A1056	90-T50F3
4031F	90-T40F3	90-T40F3	90-T40F3	AT88A1005	90-T75C3
4A420L	90-T40M1	90-T40M1	90-T40M1	AT88A1021	90-T75C3
4A424L	90-T40M3	90-T40M2	90-T40M2	BTR-403	90-T40M1
4B420L	90-T40M1	90-T40M3	90-T40M3	BTR-405	90-T40F1
4B421L	90-T40M2	90-T50C3	90-T50C3	BTR-406	90-T40F2
4E420L	90-T40F1	90-T50F3	90-T50F3	BTR-482	90-T40F3
4E421L	90-T40F2	90-T60C3	90-T60C3	GT-443	90-T40M3
50301	90-T40M3	90-T75C3	90-T75C3	GT-444	90-T40F1
50302	90-T40M1	AT120A1004	90-T40M3	GT-446	90-T40F3
50303	90-T40M2	AT140A1000	90-T40M1	S81-130	90-T40M1
50304	90-T40M3	AT140A1018	90-T40M3	S81-220	90-T40M1
50316	90-T60C3	AT140A1026	90-T40M2	S81-280	90-T40M1
5031F	90-T50F3	AT140B1032	90-T40F2	S81-318	90-T40M1
50321	90-T75C3	AT140B1206	90-T40F1	S81-330	90-T40M1
50327	90-T50C3	AT140B1214	90-T40F3	S81-373	90-T40F1
50352	90-T40F1	AT140B1388	90-T40F2	S81-374	90-T40S2
50353	90-T40F2	AT150B1237	90-T50F3	S81-407	90-T40M1
50354	90-T40F3	AT175A1008	90-T75C3	S81-424	90-T40M1
5041C	90-T50C3	AT20A1123	90-T40F3	S81-427	90-T40M1
6041C	90-T60C3	AT40A1121	90-T40F3	S81-442	90-T40M1
620-205	90-T40F1	AT40A1139	90-T40F3	S81-484	90-T40M1
620-206	90-T40F2	AT72D1006	90-T40M1	S84A-89	90-T40F1
620-402	90-T40M3	AT72D1014	90-T40M2	S84G-11	90-T40M1
620-403	90-T40M3	AT72D1022	90-T40M2	S84G-73	90-T40M1
620-404	90-T40M3	AT72D1048	90-T40M1	Y65AJ-1	90-T40M1
620-405	90-T40F1	AT72D1055	90-T40M2	Y65AP-1	90-T40M3
620-406	90-T40F2	AT72D1063	90-T40M2	Y65AR-1	90-T40M1
620-482	90-T40F3	AT72D1089	90-T40F1	Y65AS-1	90-T40F1
620-752	90-T75C3	AT72D1105	90-T40F2	Y65BR-1	90-T40M3
7541C	90-T75C3	AT72D1188	90-T40M1	Y65BS-1	90-T40F2
90-4011F	90-T40F1	AT72D1196	90-T40M2	Y65SR-1	90-T40M3



S84Z-401



S84Z-90



S84A-410



S82A-310



S84A-310

CLASS 2 TRANSFORMERS – ENERGY LIMITING

Various Standard Configurations of Step Down Transformers
Designed to Power 24 VAC Control Systems

FEATURES

- Energy limiting design, unaffected by momentary short circuit.
- Continued short circuit of secondary will cause primary winding to open in 1 to 2 minutes without creating a fire hazard.
- Maximum ambient temperature is 150°F.

SPECIFICATIONS

Agency U.L. file number E33334

SKELETON TYPE WITH VERTICAL & HORIZONTAL CHANNEL FRAMES FOR MOUNTING

Model Number	Primary to Secondary Voltages	Output Rating	Terminations	
			Line	Load
S84Z-401	120 / 208 / 240v to 25v 60Hz	40 VA	12" leads	12" leads

UNIVERSAL MOUNTED TYPES (Plate, Foot or Hub Mount)

Model Number	Primary to Secondary Voltages	Output Rating	Terminations	
			Line	Load
S84-11	120v to 25v 60Hz	40 VA	10" leads	Screw terminals
S84Z-90	120 / 208 / 240v to 25v 60Hz	40 VA	10" leads	Screw terminals

PLATE MOUNTED TYPE

Model Number	Primary to Secondary Voltages	Output Rating	Terminations	
			Line	Load
S84A-410	120v to 25v 60Hz	40 VA	10" leads	Screw terminals

HUB MOUNT Class 2 Not Wet / Class 3 Wet (C.S.A. Certified and U.L. Listed)

Model Number	Primary to Secondary Voltages	Output Rating	Terminations	
			Line	Load
*S82A-310	120v to 25v	20 VA	10" leads	Screw / spade terminals

UNIVERSAL MOUNTED TYPES (Plate, Foot or Hub Mount) Class 2 Not Wet / Class 3 Wet (C.S.A. Certified and U.L. Listed)

Model Number	Primary to Secondary Voltages	Output Rating	Terminations	
			Line	Load
*S84A-310	120v to 25v	40 VA	10" leads	Screw / spade terminals

TRANSFORMERS / RELAYS

* Indicates Canadian Model Number: call 1-800-305-6953 to order

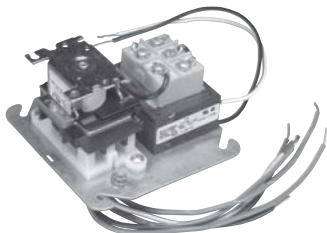

90-112 THRU 90-130
U.L. Recognized



90-340
Approximate Overall Dimensions
2 1/8" x 1 7/8" x 2 1/4"

**90-112 THRU 90-130
FAN CONTROL CENTER**

Transformer and Relay Combination for Easy Installation on a 4" x 4" Junction Box

FEATURES

- Line voltage connections pre-wired.
- Energy limiting class II transformer design.
- Color coded pre-stripped leads.
- Low voltage connections on terminal board.

SPECIFICATIONS

Agency U.L. file fan center E73641

REPLACEMENT RELAY FOR FAN CONTROL CENTER

Model Number	Replaces Relay On	Description
90-340	90-112, 90-113, 90-117 90-118E, 90-119, 90-130	DPDT Universal Plug-in Relay

Model Number	Mars Number	Transformer						Relay	Contact Ratings			
		Primary			Secondary				120 VAC (amps)		240 VAC (amps)	
		Voltage	Hz	Connections	Voltage	VA	Connections		Full Load	Locked Rotor	Full Load	Locked Rotor
90-112	24010	120	60	Color coded leads, pre-stripped	24V	40	Terminal board with 5 screw terminals	DPDT	13.8	82.8	6.9	41.4
90-113	24013	120	60	Color coded leads, pre-stripped	24V	40	Terminal board with 5 screw terminals	SPDT	13.8	82.8	6.9	41.4
90-118E	24012	120	60	Color coded leads, pre-stripped	24V	40	Terminal board with 5 screw terminals	SPNO / SPNC	13.8	82.8	6.9	41.4
90-130	24010	120 / 208 / 240	50 / 60	Color coded leads, pre-stripped	24V	40	Terminal board with 5 screw terminals	DPDT	13.8	82.8	6.9	41.4

TRANSFORMERS / RELAYS

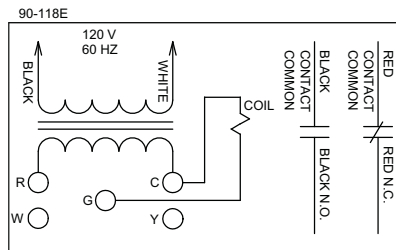
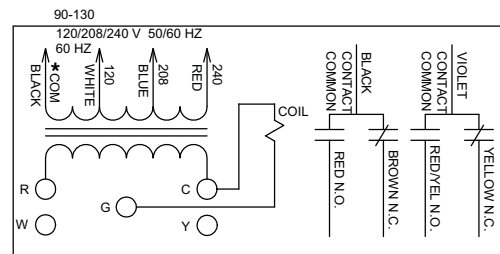
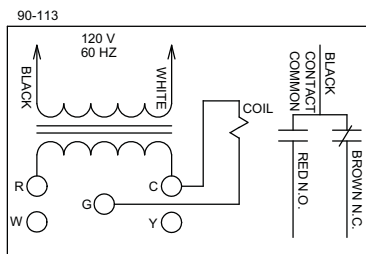
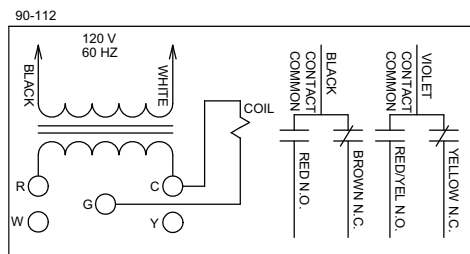

When the fan relay transformer is energized and the thermostat completes the connection from R to G the fan relay coil energizes. Line voltage power applied to contact common path travels to selected blower speed tap. Additional terminal Y and W are isolated tie point terminals to connect thermostat wiring to compressor and furnace (if required).

Note: Record the lead wire color with it's corresponding terminal for future reference. Unused transformer input leads must be insulated.

* Black is common with respect to transformer winding, not external circuit.



8A04-1

SPDT FAN RELAYS

For 24V AC Control of Blowers and Other Line Voltage Loads on Heating, Cooling or Heating/Cooling Systems where 24V Power Supply is Already Available

FEATURES

- Compact size — 1/2" conduit hub permits mounting to standard junction box.
- Provisions for mounting to flat surface.
- Permits control of single or two speed fan motor.
- 5 color coded, end stripped leads for easy wiring.

SPECIFICATIONS

Dimensions 2¹¹/₁₆" H x 2¹⁵/₁₆" W x 1¹/₂" D
 Finish Grey
 Mounting Mounting tabs or 1/2" conduit hub
 Agency U.L. listed and C.S.A. approved

Model Number	Coil Input Voltage	Switch Action	Coil Current	Contact Ratings			
				N.O. (Black-Red)		N.C. (Black-Brown)	
				120 VAC	240 VAC	120 VAC	240 VAC
8A04-1	24 VAC, 60 Hz	SPDT	0.28A	16.0 FLA/96.0 LRA	8.0 FLA/48.0 LRA	9.8 FLA/58.8 LRA	6.9 FLA/41.4 LRA

COOLING / REFRIGERATION

RELAY/TRANSFORMER COMBINATIONS

DPST Relay Models Enclosed with a Transformer Capable of Powering External Loads up to 35VA. Ideal for use on Boilers Without Domestic Coil. Equally Adaptable for Zoned and Unzoned Systems



FEATURES

- Low voltage screw terminals — color coded, end stripped line voltage leads.
- Internal transformer can power up to 35VA external loads.
- Mounts to 4" x 4" junction box.
- Dustproof steel case.

SPECIFICATIONS

Dimensions 4¹/₄" H x 2³/₄" W x 2³/₄" D
 Finish Grey
 Mounting To 4" x 4" junction box
 Transformer 35 VA maximum connected external load
 Agency U.L. recognized and C.S.A. approved

Model Number	Input Voltage	Switch Action	Thermostat Current	Contact Ratings			
				Motor Rating		Valves & Relays	
				120 VAC		Terminals V1 & V2	
				Full Load	Locked Rotor	30 VAC	0.3-12v DC
8A05A-4	120 VAC, 60 Hz	DPST	0.28A	10.0A/16.0A	60.0A/96.0A	—	—
8A05A-101	120 VAC, 60 Hz	DPST	0.13A	8.0A/14.0A	48.0/84.0A	—	—

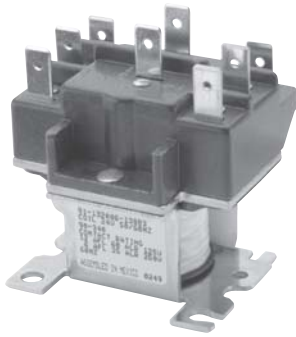

90-340

Approximate Overall Dimensions
2 1/8" x 1 7/8" x 2 1/4"



90-340 THRU 90-342 WR / RBM TYPE 91

A Two Pole Double Throw Semi-Enclosed Relay

90-340 Fits Fan Control Centers 90-112, 90-113, 90-118E and 90-119

FEATURES

- Easy to install.
- Suited for use in vending machines, appliances, heating and air conditioning applications and general purpose switching.

SPECIFICATIONS

Temperature Range	-40°F to 130°F
Mechanical Life (no load)	1,000,000 operations, 120 operations/min.
Electrical Life (rated load)	100,000 operations, 6 operations/min.
		Load test making inrush ratings (0.4 to 0.5 P.F.); breaking 100% continuous rating (0.65 to 0.8 P.F.)
Weight (approximate)	6 oz
Agency	U.L. file number E12139 C.S.A. file number LR13360
Coils, Frequency	50 / 60 Hz
Coils, Insulation	Class B
Coils, Termination	1/4" Quick Connect
Coils, Operate	85% of nominal coil voltage; 110% maximum safe operate
Coils, Duty Cycle	Continuous

TWO POLE DOUBLE THROW (2PDT) Fits Fan Control Center Receptacles

Model Number	Coil Voltage (50 / 60 Hz)	Terminals 1-2-3	Terminals 4-5-6	COIL DATA			
				DC Res.	MA	Nom. VA	Inrush VA
90-340	24	Power	Power	17.5	334	9.5	22
90-341	115 / 120	Power	Power	420	66	9.5	22
90-342	208 / 240	Power	Power	1600	38	9.5	22

COIL RATING

Voltage: 24 VAC
Cycle: 50 / 60 Hz
Volt: Amps
Inrush: 21.5
Sealed: 9.5
Resistance: 17.5Ω ± 10%

CONTACT RATINGS

12FLA / 60LRA
125 VAC
6FLA 35LRA
250 / 277 VAC
15A 277 VAC RES
1/2HP 125 / 250 VAC

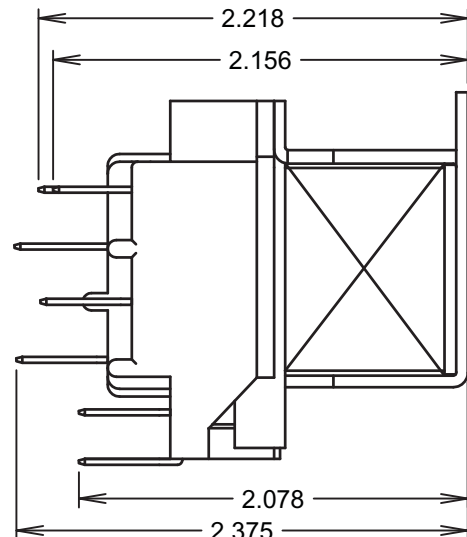
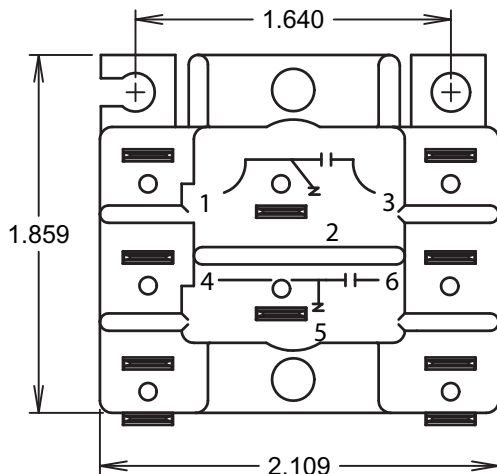

1 POLE DEFINITE PURPOSE CONTACTORS WITH BUS BAR (30A THRU 40A)

White
Rodgers.

40 Amp Model
(with cover)



Approximate Overall Dimensions
3 1/4" x 2" x 2 1/2"

94-388 THRU 94-396 WR / RBM TYPE 121

Straight-Through Wiring, Replaces 1 1/2 Pole Devices Used Primarily in Residential Central Air Conditioning

FEATURES

- Replaces many contactors used by OEM's.
- Universal style mounting bracket fits existing mounting holes.
- Screw terminals and 1/4" quick connect terminals for easy installation.

SPECIFICATIONS

Temperature Range	-40°F to 150°F
Mechanical Life (no load)	Conforms to UL and ARI specifications
Electrical Life	Conforms to ARI specifications
	94-388 thru 94-390 achieve 200,000 cycles, make LRA at .5 pf, break 125% of FLA at .75 pf at rated voltage, 10,000 cycles make and break LRA at .5 pf rated voltage
	94-394 thru 94-396 achieve 100,000 cycles, make LRA at .5 pf, break 125% of FLA at .75 pf at rated voltage, 6,000 cycles make and break LRA at .5 pf rated voltage
Weight (approximate)	7 oz.
Agency	U.L. file number E12139
Coils Frequency	50 / 60 Hz
Coil Insulation	Class B (130°C)
Termination	Screw and Double 1/4" Q.C.
Operate	85% of nominal coil voltage; 110% maximum safe operate
Duty Cycle	Continuous

COIL DATA

Model Number		Voltage AC	Res DC OHMS	Current MA	Nominal VA	Max. Inrush VA
* 30 Amp	** 40 Amp					
94-388	94-394	24	16.5	208	5	20
94-389	94-395	120	420	42	5	20
94-390	94-396	208 / 240	1825	21	5	20

* 30 amp models have no cover on top as in line drawing below
** 40 amp models have cover on top as in picture above

CONTACT RATINGS

Type	Voltage	FLA	LRA	RES
94-388	277	30	150	40
thru	480	30	75	40
94-390	600	30	50	40
94-394	277	40	200	50
thru	480	40	100	50
94-396	600	40	80	50

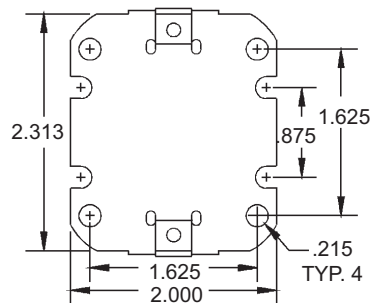
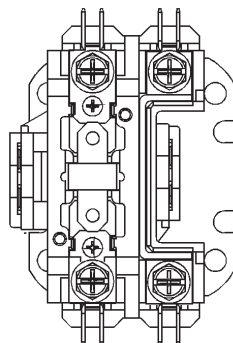
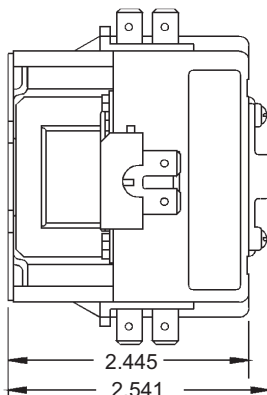

30 Amp Model (No Cover)

TRANSFORMERS / RELAYS

**40 Amp Model
(with cover)**



Approximate Overall Dimensions
3 1/4" x 2" x 2 5/8"



90-244 THRU 90-249 WR / RBM TYPE 122

Designed for Air Conditioning and Heating Equipment

FEATURES

- Low VA coil for cooler operation and increased life.
- Quiet operation.
- Universal style mounting bracket fits existing mounting holes.
- Double break contacts ensure positive make and break.
- Screw terminals or pressure connectors and double 1/4" quick connects provided on all models for easy installation.

SPECIFICATIONS

Insulating Material	Contact block and carrier are high quality electrical-grade thermosetting resin
Temperature Range	-40°F to 150°F
Mechanical Life	Conforms to UL and ARI specifications
Electrical Life	Conforms to UL and ARI specifications
Weight (approximate)	9.5 oz.
Agency	U.L. file number E12139
Coils Frequency	50 / 60 Hz
Coil Insulation	Class B (130°C)
Termination	Pressure Connectors and Double 1/4" Q.C.
Operate	85% of nominal coil voltage; 110% maximum safe operate
Duty Cycle	Continuous

COIL DATA

Model Number		Voltage AC	Res DC OHMS	Current MA	Nominal VA	Max. Inrush VA
* 30 Amp	** 40 Amp					
90-244	90-247	24	11	250	6	32
90-245	90-248	120	224	50	6	32
90-246	90-249	208 / 240	997	25	6	32

* 30 amp models have no cover on top as in line drawing below
** 40 amp models have cover on top as in picture above

CONTACT RATINGS

Type	Voltage	FLA	LRA	RES
90-244 thru 90-246	277	30	150	40
	480	30	75	40
	600	30	50	40
90-247 thru 90-249	277	40	200	50
	480	40	100	50
	600	40	80	50

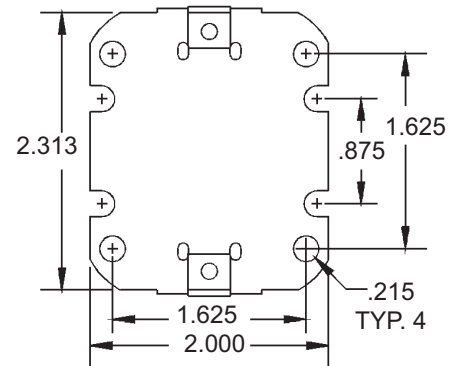
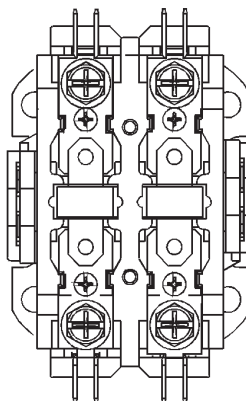
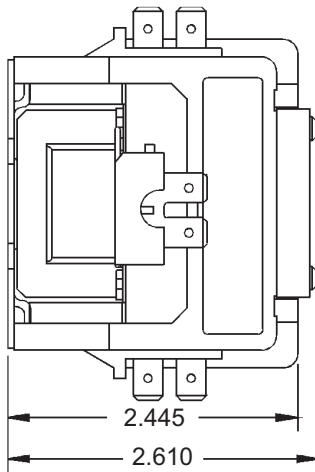

30 Amp Model (No Cover)

3 POLE DEFINITE PURPOSE CONTACTORS (25A THRU 40A)

White
Rodgers.

40 Amp with Cover

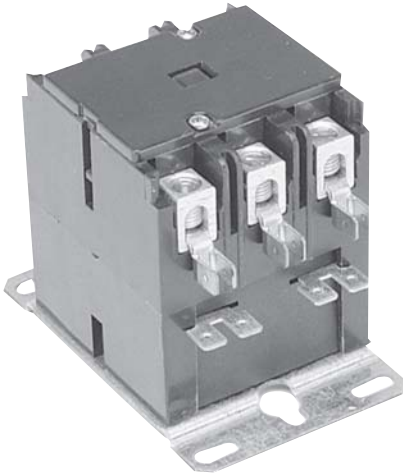

Approximate Overall Dimensions
3³/₄" x 2³/₈" x 3"

Pressure Connectors line and load sides for #14 thru #4 wire. 1/4" Double Quick Connect auxiliary and coil terminals.



90-160 THRU 90-172 WR / RBM TYPE 154

Designed for Central Air Conditioning and Heating Equipment

FEATURES

- Any position mounting.
- Interchangeable mounting plate.
- Low wattage coil.
- Double break contacts ensure positive make and break.

SPECIFICATIONS

Insulating Material	Contact block and carrier are high quality electrical-grade thermosetting resin
Temperature Range	-40°F to 150°F
Mechanical Life	Conforms to UL and ARI specifications
Electrical Life	Conforms to UL and ARI specifications
Weight (approximate)	16 oz.
Agency	U.L. file number E12139
Coils Frequency	50 / 60 Hz
Coil Insulation	Class B (130°C)
		24 through 208 / 240 Volts AC
Termination	Pressure connector and Double 1/4" Q.C.
Operate	85% of nominal coil voltage;
		110% maximum safe operate
Duty Cycle	Continuous

COIL DATA – 25, 30 and 40 Amp, 600 Volt Three Pole Normally Open (3 P.N.O.)

Model Number			Coil Voltage AC (60 Hz)	Res DC OHMS	Current MA	Nominal VA	Max. Inrush VA
25 Amp	30 Amp	40 Amp					
90-160	90-163	90-170	24	7.2	187	4.5	52
90-161	90-164	90-171	120	180	37	4.5	52
90-162	90-165	90-172	208 / 240	720	19	4.5	52

CONTACT RATINGS – 25 and 30 Amp, 600 Volt Three Pole Normally Open (3 P.N.O.)

Type	Voltage	277 VAC	480 VAC	600 VAC
90-160 thru 90-162	Full Load	25 A.	25 A.	25 A.
	Lock Rotor	150 A.	125 A.	100 A.
	Resistive	40 A.	40 A.	40 A.
90-163 thru 90-165	Full Load	30 A.	30 A.	30 A.
	Lock Rotor	180 A.	150 A.	120 A.
	Resistive	50 A.	50 A.	50 A.

CONTACT RATINGS – 40 Amp, 600 Volt Three Pole Normally Open (3 P.N.O.)

Type	Voltage	277 VAC	480 VAC	600 VAC
90-170 thru 90-172	Full Load	40 A.	40 A.	40 A.
	Lock Rotor	240 A.	200 A.	160 A.
	Resistive	50 A.	50 A.	50 A.

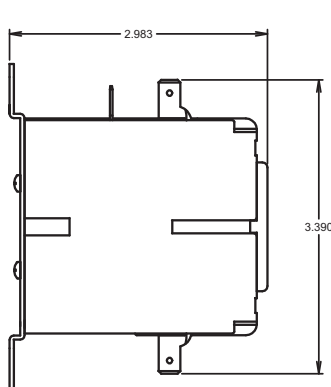

90-160 thru 90-172

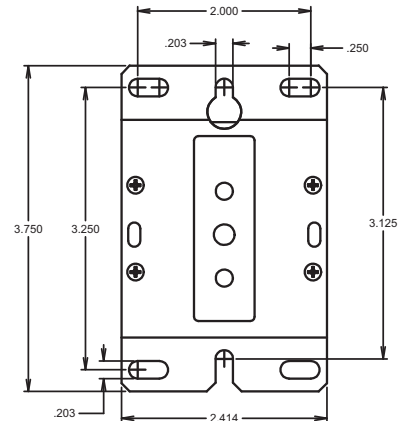
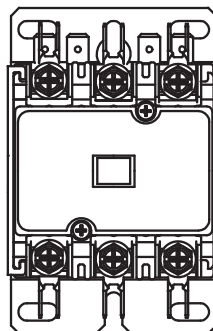

**92-459 THRU 92-472
3 POLE HEAVY DUTY CONTACTORS**

FEATURES

- Interchangeable mounting.
- Double break contacts.
- Box lugs and dual quick connect terminals.

SPECIFICATIONS

Coils, Voltages A.C.	24 through 240
Coils, Frequency.	50 / 60 Hz
Coils, Termination.	Single or Double 1/4" Q.C.
Contacts, Pole Form.	3 PNO
Contacts, Material.	Silver cadmium oxide (50-90 amp)
Contacts, Termination.	Box lugs and dual quick connect
Agency	U.L. file number E22381

COIL DATA

50 Amp.	60 Amp.	Voltage A.C.	Res. D.C. OHMS	Current Ma.	Nominal VA	Max. Inrush VA
92-459	92-463	24	2.4	580	14	135
92-460	92-464	120	45.5	117	14	135
92-461	90-465	208 / 240	280	50	14	135

75 Amp.	90 Amp.	Voltage A.C.	Res. D.C. OHMS	Current Ma.	Nominal VA	Max. Inrush VA
92-467		24	0.63	1125	27	240
92-468	92-472	120	15.5	225	27	240
92-469		208/240	63.5	112	27	240

Contact Ratings

Model Number	Induct FLA	Resistive Per Pole	Locked Rotor	@ Line Voltage
92-459	50 Amp	65 Amp	300 Amp	120v
92-460	50 Amp	65 Amp	300 Amp	240v
92-461	50 Amp	65 Amp	200 Amp 200 Amp	480v 600v

Model Number	Induct FLA	Resistive Per Pole	Locked Rotor	@ Line Voltage
92-463	60 Amp	75 Amp	360 Amp	120v
92-464	60 Amp	75 Amp	360 Amp	240v
92-465	60 Amp	75 Amp	300 Amp 240 Amp	480v 600v

Model Number	Voltage	FLA	LRA	RES
92-467	120 / 240	75	450	93
92-468	480	75	375	93
92-469	600	75	300	93
92-472	120 / 240	90	540	120
	480	90	450	120
	600	90	360	120



Approximate Overall Dimensions
3 3/4" x 2 5/8" x 3 1/2"
(92-459 thru 92-465)

TRANSFORMERS /
RELAYS

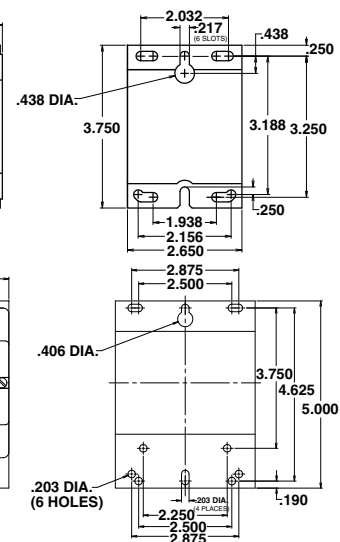
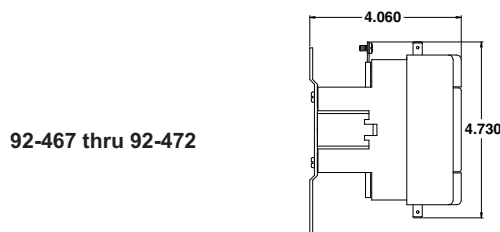
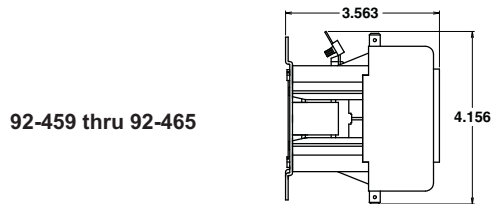



90-63

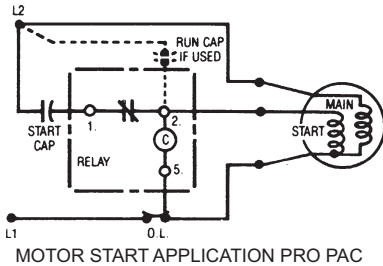

**90-63 THRU 90-71 TYPE 128000
UNIVERSAL BRACKET**

Unmatched Versatility

FEATURES

- Replaces thousands of OEM models.
- Universal break-off bracket for mounting flexibility.
- Guide to replace GE, RBM and other Steveco 90-#s included with each relay.

SPECIFICATIONS

Temperature Range	-40°F to 130°F
Mechanical Life (no load)	500,000 operations, 60 operations/min
Electrical Life (rated load)	Meets U.L. and ARI specifications
Outline Drawings	
Weight (approximate)	6.5 oz. each
Agency	U.L. file number SA1984 C.S.A. file number LR13360
Class Insulation	Class B
Duty Cycle	Continuous

Model Number	Mars Number	Continuous Coil Voltage	Pick-up		Drop Out Max.	Coil Data			
			Min.	Max.		DC Res.	MA	Nom. VA	Inrush VA
90-63	19002	170	140	153	65	1,399	29.0	5	10
90-64	19003	395	245	275	140	7,147	12.7	5	10
90-65	19004	336	171	184	90	5,180	15.0	5	10
90-66	19005	395	208	239	130	7,147	12.7	5	10
90-67	19006	420	300	328	121	10,000	12.0	5	10
90-68	19007	495	323	352	135	11,950	10.0	5	10
90-26	19008	395	180	195	100	7,147	12.7	5	10
90-71	19010	420	223	252	150	10,000	12.0	5	10



TRANSFORMERS / RELAYS

POTENTIAL RELAYS CROSS REFERENCE

Model Number	Suggested Replacement	Model Number	Suggested Replacement	Model Number	Suggested Replacement	Model Number	Suggested Replacement	Model Number	Suggested Replacement
128-116-1355S	90-26	82139-1	90-63	82239	90-65	82529	90-64	82594	90-65
128-416-1324M	90-63	82139-2	90-63	82240	90-65	82530	90-67	82595	90-68
128-416-1344R	90-65	82139-3	90-63	82242	90-64	82530-3	90-67	82596	90-68
128-416-1354A	90-64	82139-4	90-63	82243	90-64	82531	90-67	82597	90-66
128-416-1354U	90-66	82140	90-67	82244	90-64	82531-3	90-67	82598	90-65
128-416-1364V	90-71	82140-2	90-67	82245	90-66	82532	90-67	82599	90-68
128-416-1374F	90-68	82140-3	90-67	82250	90-64	82532-3	90-67	82759	90-66
128-900-1144B	90-64	82140-4	90-67	82252	90-67	82537	90-63	82762	90-64
128-900-1154B	90-68	82141	90-67	82256	90-65	82538	90-63	82763	90-63
128-900-1344B	90-67	82142	90-67	82257	90-68	82539	90-63	82764	90-68
128-900-1361K	90-68	82142-1	90-67	82261	90-66	82539-3	90-63	82765	90-64
128-900-1371K	90-63	82143	90-68	82262	90-65	82540	90-63	82768	90-67
128-900-1381K	90-67	82143-1	90-68	82263	90-68	82540-3	90-63	82800	90-66
128-900-1421K	90-65	82144	90-64	82268	90-64	82541	90-63	82801	90-66
128-900-1454B	90-67	82146	90-64	82269	90-64	82541-3	90-63	82802	90-64
128-900-1474	90-63	82146-1	90-64	82270	90-66	82542	90-65	82803	90-64
128-900-1486B	90-68	82147	90-67	82271	90-64	82542-1	90-65	82804	90-66
128-900-1501K	90-68	82147-1	90-67	82272	90-64	82542-3	90-65	82805	90-64
128-900-1521K	90-64	82148	90-63	82273	90-66	82548	90-64	82806	90-64
128-900-1593K	90-68	82148-1	90-63	82291	90-67	82549	90-67	82808	90-64
128-900-1603K	90-68	82150	90-67	82296	90-64	82549-3	90-67	82809	90-63
128-900-1623K	90-65	82150-1	90-67	82297	90-64	82550	90-67	82811	90-26
128-900-1693K	90-64	82151	90-68	82298	90-66	82550-3	90-67	82812	90-67

Model Number	Suggested Replacement	Model Number	Suggested Replacement	Model Number	Suggested Replacement	Model Number	Suggested Replacement	Model Number	Suggested Replacement
128-900-1734B	90-65	82151-1	90-68	82435	90-64	82552	90-64	82814	90-64
128-990-1073	90-68	82152	90-64	82439	90-67	82552-3	90-64	82815	90-67
128-990-1246B	90-65	82152-1	90-64	82457	90-65	82553	90-64	82816	90-64
19002	90-63	82153	90-64	82467	90-26	82553-3	90-64	82817	90-64
19003	90-64	82153-1	90-64	82477	90-65	82556	90-64	82818	90-64
19004	90-65	82155	90-64	82501	90-65	82556-3	90-64	82819	90-66
19005	90-66	82155-1	90-64	82502	90-65	82557	90-66	82820	90-67
19006	90-67	82158	90-67	82503	90-68	82557-3	90-66	82825	90-64
19007	90-68	82158-1	90-67	82504	90-68	82558	90-66	82826	90-64
19008	90-26	82159	90-64	82504-3	90-68	82558-3	90-66	82827	90-67
19009	90-67	82159-1	90-64	82505	90-63	82559	90-65	82831	90-65
19010	90-71	82160	90-64	82505-1	90-63	82559-3	90-65	82832	90-63
4E653	90-64	82160-1	90-64	82507	90-67	82561	90-64	82835	90-63
4E654	90-65	82163	90-67	82507-3	90-67	82562	90-67	82836	90-68
4E655	90-66	82163-1	90-67	82508	90-67	82563	90-67	82837	90-64
4E656	90-67	82165	90-65	82508-1	90-67	82564	90-67	82838	90-67
4E657	90-68	82170	90-67	82508-2	90-67	82565	90-65	82839	90-64
600-063	90-63	82171	90-64	82508-3	90-67	82567	90-67	82840	90-67
600-064	90-64	82173	90-67	82509	90-65	82568	90-65	82841	90-65
600-065	90-65	82177	90-67	82509-3	90-65	82569	90-64	82842	90-64
600-066	90-66	82198	90-67	82510	90-65	82570	90-26	82843	90-26
600-067	90-67	82204	90-63	82510-3	90-65	82571	90-67	82845	90-65
600-068	90-68	82209	90-66	82513	90-67	82572	90-63	82847	90-66
600-071	90-71	82211	90-64	82513-3	90-67	82573	90-68	82850	90-64
8200128A01	90-67	82212	90-64	82514	90-67	82574	90-63	82851	90-68
8200128A02	90-63	82213	90-65	82514-3	90-67	82575	90-64	82852	90-64
8200128A04	90-66	82214	90-66	82515	90-68	82576	90-64	90002	90-63
8200128A80	90-64	82215	90-63	82515-3	90-68	82577	90-68	90003	90-65
8200128A83	90-64	82216	90-67	82516	90-64	82578	90-66	90004	90-64
82068	90-67	82217	90-67	82516-3	90-64	82579	90-66	90005	90-66
820ARR3A03	90-66	82218	90-65	82517	90-64	82580	90-68	90006	90-67
820ARR3A16	90-64	82219	90-65	82517-3	90-64	82581	90-65	90007	90-68
820ARR3A79	90-64	82221	90-64	82520	90-63	82582	90-65	90008	90-26
820ARR3A82	90-64	82223	90-66	82521	90-64	82583	90-67	90010	90-71
820ARR3B04	90-65	82224	90-66	82521-3	90-64	82584	90-64	90011	90-64
821140-1	90-67	82225	90-66	82522	90-68	82585	90-64	90012	90-68
82135	90-67	82228	90-66	82523	90-64	82586	90-64	90013	90-64
82135-1	90-67	82229	90-63	82523-3	90-64	82587	90-65	90014	90-64
82136	90-65	82230	90-68	82524	90-63	82588	90-65	90015	90-67
82137	90-65	82231	90-64	82525	90-67	82589	90-68	90016	90-68
82137-1	90-65	82232	90-67	82526	90-67	82590	90-67	90017	90-63
82138	90-65	82233	90-67	82527	90-65	82591	90-64	90018	90-67
82138-1	90-65	82234	90-64	82527-3	90-64	82592	90-68	90020	90-68
82139	90-63	82236	90-66	82528	90-64	82593	90-65	90021	90-63
90022	90-64	82237	90-66	82528-3	90-64	90025	90-68	90026	90-26
90027	90-66	90023	90-68	90024	90-65	90-13	90-64	90-14	90-64
90-15	90-67	90-1	90-63	90-10	90-66	90-18	90-67	90-2	90-67
90-20	90-68	90-16	90-68	90-17	90-63	90-23	90-68	90-26	90-65
90-27	90-66	90-21	90-63	90-22	90-64	90-5	90-67	90-6	90-67
90-63	90-63	90-3	90-65	90-4	90-64	90-66	90-66	90-67	90-67
90-68	90-68	90-64	90-64	90-65	90-65	90-71	90-71	90-8	90-67
90-9	90-68	90-7	90-65	82551	90-64				



Approximate Overall Dimensions
2³/₈" x 1⁵/₈" x 1¹/₂"

90-290Q THRU 90-295Q WR / RBM TYPE 84

Used for Switching Single or Two Speed Fan Motors, Solenoids, Relays, Resistive Loads and General Purpose Switching

FEATURES

- Compact, totally enclosed design.
- For heating and cooling applications and general switching.
- Quiet, reliable and economical.

SPECIFICATIONS

Temperature Range	-40°F to 150°F
Mechanical Life (no load)	1,000,000 operations, 60 operations/min.
Electrical Life (rated load)	100,000 operations, 6 operations/min. Load test making inrush rating (0.4 to 0.5 P.F.); breaking 100% continuous rating (0.64 to 0.8 P.F.)
Weight (approximate)	2.5 oz.
Agency	U.L. file number E12139 or E22381 C.S.A. file number LR13360
Coils, Frequency	50 / 60 Hz
Coils, Insulation	Class B
Coils, Termination	1/4" Quick Connect
Coils, Operate	85% of nominal coil voltage; 110% maximum safe operate
Coils, Duty Cycle	Continuous

SINGLE POLE NORMALLY OPEN (SPNO), SINGLE POLE DOUBLE THROW (SPDT)

Model Number		Coil Voltage AC (50/60 Hz)	Res DC OHMS	Coil Data		Inrush VA
SPNO	SPDT			Nom. Current MA	Nominal VA Sealed	
90-290Q	90-293Q	24	90	125	3	4
90-291Q	90-294Q	120	2,000	25	3	4
90-292Q	90-295Q	240	7,000	12.5	3	4

CONTACT RATING 125 / 250 VAC

Inductive	Resistive
8 Amps Continuous 25 Amps. Inrush	16 Amps Continuous

WIRING DIAGRAMS

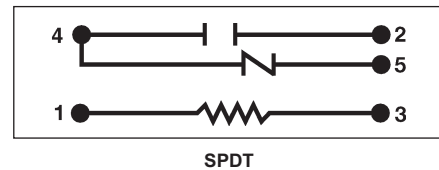
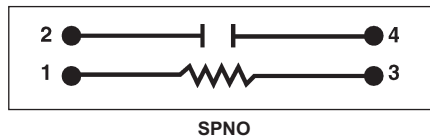

90-360 THRU 90-486 WR / RBM TYPE 184

Heavy-Duty General Purpose Relay Operates in Any Position



Totally Enclosed Relay

Operates in Any Position
Isolated Coil and Mounting Bracket

FEATURES

- Compact, totally enclosed design.
- For heating and cooling applications and general switching.
- Quiet, reliable and economical.

SPECIFICATIONS

Temperature Range	-40°F to 150°F
Mechanical Life (no load)	1,000,000 operations, 120 operations/min.
Electrical Life (rated load)	100,000 operations, 6 operations/min.
	Load test making inrush rating (0.4 to 0.5 P.F.); breaking 100% continuous rating (0.65 to 0.8 P.F.)
Weight (approximate)	2.3 oz.
Agency	U.L. file number E12139 or E22381 C.S.A. file number LR13360
Coils, Frequency	50 / 60 Hz
Coils, Insulation	Class B
Coils, Termination	1/4" Quick Connect
Coils, Operate	85% of nominal coil voltage; 110% maximum safe operate
Coils, Duty Cycle	Continuous

SINGLE POLE NORMALLY OPEN, SINGLE POLE DOUBLE THROW (SPDT) ISOLATED CONTACTS (SPNO / SPNC)

Model Number			Coil Voltage AC (50/60 Hz)	Res DC OHMS	Coil Data		Inrush VA
SPNO	SPDT	SPNO/SPNC			Nom. Current MA	Nominal VA Sealed	
90-360	90-370	90-380	24	77	125	3	4
90-362	90-372	90-382	120	2,000	25	3	4
90-364	90-374	90-384	240	6,050	12.5	3	4
90-466	90-476	90-486	277	10,300	10.8	3	4

CONTACT RATING

Inductive	Resistive
12 Amps. Continuous 60 Amps. Inrush @ 125 VAC	18 Amps. Continuous @ 277 VAC
8 Amps. Continuous 48 Amps. Inrush @ 250 VAC	

WIRING DIAGRAMS



SPNO

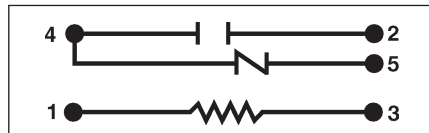

SPDT

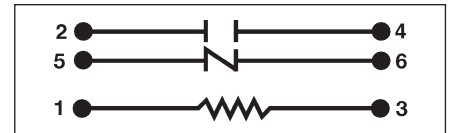

SPNO / SPNC

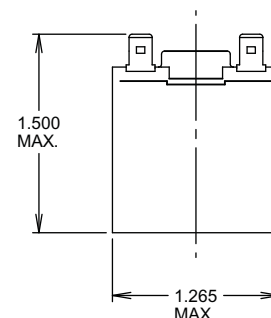
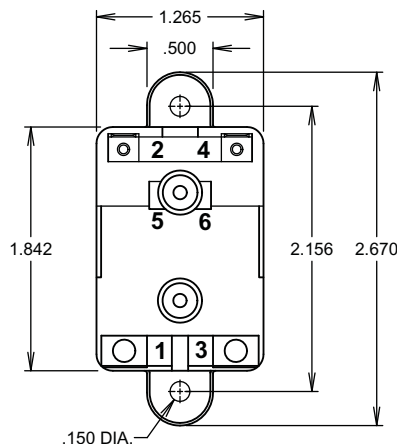



Type 70 SPNO

WARNING – FIRE HAZARD

Must be installed in a dry and protected place. Failure to protect solenoid from water and other contaminants could result in Fire, Property Damage, Serious Personal Injury, or Death.

TYPE 70 SPNO

Single Pole Normally Open Contact, Case is Dust Resistant and Isolated from Ground.

SPECIFICATIONS

Dimensions 2.47" L x 3.48" W x 2.40" H
 Weight 14 oz.
 Temperature Range -40° to +122°F
 Terminations, Contacts 5/16"-24 UNF-2A thread
 Terminations, Coil #10-32 UNF-2A thread
 Recommended Mounting Plunger vertical with cap down
 Hardware Torque, Contact Terminal 45-55 in. lbs.
 Hardware Torque, Coil Terminal 12-18 in. lbs.
Caution: A back-up wrench must be used to hold the bottom nut stationary.
 Agency U.L. 538 Recognized, File AU2138

Model Number	Duty Cycle ③	Terminal Type ①	Pole Form	Bracket Style	Coil Voltage D.C.	Coil Resistance (Ohms) ②	Contact Material	Contact Rating (Amps) – Inductive Load		
								Voltage		Normally Open
								D.C.	Continuous	Inrush
70-111225	Continuous	3A	SPNO	Standard	12	16	Copper	12	80	300
70-111224	Continuous	4	SPNO	Standard	12	16	Copper	12	80	150
70-117224	Continuous	4	SPNO	Standard	24	60	Copper	24	50	50
70-120224	Continuous	4	SPNO	Standard	36	114	Copper	36	50	50

- ① "3A" = Coil Grounded to Case
"4" = Isolated Coil
- ② Coil resistance in Ohms @ 25°C
- ③ Intermittent duty designs available.

TRANSFORMERS / RELAYS

TYPE 120 SPNO

Single Pole Normally Open Contact, Dust Resistant, Water Resistant and Case is Isolated from Bracket

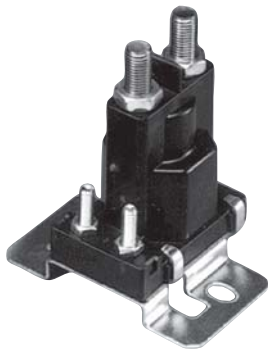

Type 120 SPNO

SPECIFICATIONS

Dimensions 2.13" L x 2.88" W x 3.09" H (Std. Bracket)
 Dimensions 2.50" L x 3.00" W x 3.03" H (L-Shaped Bracket)
 Weight 6.0 oz.
 Temperature Range, Intermittent Duty -20° to +150°F
 Temperature Range, Continuous Duty -20° to +120°F
 Terminations, Contacts 5/16"-24 studs, .495" min. length
 Terminations, Coil #10-32, .451" min. length
 Recommended Mounting Coil terminals up or horizontal
 Hardware Torque, Contact Terminal 45-55 in. lbs.
 Hardware Torque, Coil Terminal 12-18 in. lbs.
Caution: A back-up wrench must be used to hold the bottom nut stationary.

Model Number	Duty Cycle ①	Terminal Type ②	Pole Form	Bracket Style	Coil Voltage D.C.	Coil Resistance (Ohms) ③	Contact Material	Contact Rating (Amps) – Inductive Load		
								Voltage		Normally Open
								D.C.	Continuous	Inrush ④
120-105711	Continuous	4	SPNO	Standard	12	16	Silver Alloy	12	100	400
120-105851	Continuous	3A	SPNO	Standard	12 ⑤	16	Silver Alloy	12	100	400
120-106131	Intermittent	4	SPNO	Standard	12	6.0	Copper	12	80	400
120-106132	Intermittent	4	SPNO	L	12	6.0	Copper	12	80	400
120-107112	Continuous	4	SPNO	L	14	26.0	Silver Alloy	14	100	400

- ① Intermittent Duty Cycle = 30 seconds "ON" maximum and 6 minutes "OFF"
- ② "4" = Isolated Coil
- ③ Coil resistance in Ohms @ 25°C
- ④ Inrush Current: Current applied within the first 1/2 second of contact closure
- ⑤ Coil grounded to bracket

NOTE: CAUTION must be used in coil selection for use in 12 volt systems where battery charging may expose coil to continuous, higher-than-rated voltage. 14 volt coils are recommended. White-Rodgers will not be responsible for consequences of misapplied solenoids.

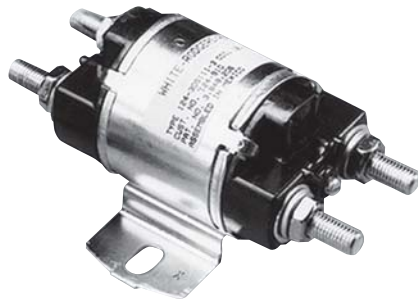

Type 124

TYPE 124

Single Pole Normally Open, or Single Pole Double Throw Contacts.
Dust Resistant and Endcaps are Isolated from Bracket

SPECIFICATIONS

Dimensions, 124-105111,-114111,-117111 3.56" L x 3.13" W x 2.19" H
 Dimensions, 124-305111,-314111 4.69" L x 3.13" W x 2.19" H
 Weight, 124-105111,-114111,-117111 16.0 oz.
 Weight, 124-305111,-314111 19.0 oz.
 Temperature Range -40° to +149°F
 Terminations, Contacts 5/16" -24 UNF-2A thread
 Terminations, Coil #10-32 UNF-2A thread
 Recommended Mounting Vertical plane with coil terminals up
 Hardware Torque, Contact Terminal 60 in. lbs. max.
 Hardware Torque, Coil Terminal 12-18 in. lbs.

Caution: A back-up wrench must be used to hold the bottom nut stationary.

Model Number	Duty Cycle	Terminal Type ①	Bracket Style	Coil Voltage D.C.	Coil Resistance (Ohms) ②	Contact Material	Contact Rating (Amps) – Inductive Load				
							Voltage D.C.	Normally Open		Normally Closed	
124-105111	Continuous	4	Standard	12	13.2	Silver Alloy	12	100	400	–	–
124-114111	Continuous	4	Standard	24	53.0	Silver Alloy	24	100	400	–	–
124-314111	Continuous	6	Standard	24	53.0	Silver Alloy	24	100	400	50	100
124-117111	Continuous	4	Standard	36	120.0	Silver Alloy	36	100	400	–	–
124-317111	Continuous	6	Standard	36	120.0	Silver Alloy	36	100	400	50	100

- ① "4" = Isolated Coil, SPNO
"6" = Isolated Coil, SPDT
- ② Coil resistance in Ohms @ 25°C
- ③ Inrush Current: Current applied within the first 1/2 second of contact closure



Type 586 SPNO

TYPE 586

Single Pole Normally Open, or Single Pole Double Throw Contacts.
Water Resistant and Case is Isolated from Bracket.

SPECIFICATIONS

Dimensions, 586-114111,-117111 3.69" L x 3.30" W x 2.90" H
 Dimensions, 586-317111 4.61" L x 3.30" W x 2.90" H
 Weight, 586-114111,-117111 24.0 oz.
 Weight, 586-317111 26.0 oz.
 Temperature Range -40° to +149°F
 Terminations, Contacts 5/16" -24 UNF-2A thread
 Terminations, Coil #10-32 UNF-2A thread
 Recommended Mounting Vertical plane with coil terminals up
 Hardware Torque, Contact Terminal 60 in. lbs. max.
 Hardware Torque, Coil Terminal 12-18 in. lbs.

Model Number	Duty Cycle	Terminal Type ①	Bracket Style	Coil Voltage D.C.	Coil Resistance (Ohms) ②	Contact Material	Contact Rating (Amps) – Inductive Load				
							Voltage D.C.	Normally Open		Normally Closed	
586-105111	Continuous	4	Standard	12	21.0	Silver Alloy	12	200	600	–	–
586-108111 ④	Continuous	4	Standard	15	32.8	Silver Alloy	15	200	600	–	–
586-114111	Continuous	4	Standard	24	84.0	Silver Alloy	24	200	600	–	–
586-117111	Continuous	4	Standard	36	189.0	Silver Alloy	36	200	600	–	–
586-120111	Continuous	4	Standard	48	336.0	Silver Alloy	36	200	600	–	–
586-314111	Continuous	6	Standard	24	84.0	Silver Alloy	24	200	600	100	200
586-317111	Continuous	6	Standard	36	120.0	Silver Alloy	36	200	600	100	200

- ① "4" = Isolated Coil, SPNO
"6" = Isolated Coil, SPDT
- ② Coil resistance in Ohms @ 25°C
- ③ Inrush Current: Current applied within the first 1/2 second of contact closure
- ④ Ideal for 12V charging systems

NOTE: CAUTION must be used in coil selection for use in 12 volt systems where battery charging may expose coil to continuous, higher-than-rated voltage. 15 volt coils are recommended. White-Rodgers will not be responsible for consequences of misapplied solenoids.