

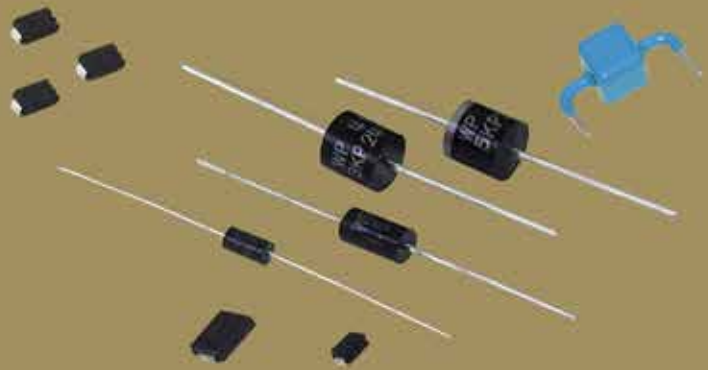

WORLD PRODUCTS INC.

TVS DIODES



WORLD PRODUCTS INC. || 19654 Eighth Street East || P.O. Box 517 || Sonoma, CA 95476
Phone: (707) 996.5201 || FAX: (707) 996.3380 || www.worldproducts.com || sales@worldproducts.com
©2013 World Products Inc.



THIS PAGE WAS INTENTIONALLY LEFT BLANK.

Table of Contents

Transient Voltage Suppression Diodes 1

General Information 2

P4KE Series — 400 Watt 8

SA Series — 500 Watt 12

P6KE Series — 600 Watt 18

1.5KE Series — 1500 Watt 22

3KP Series — 3000 Watt 26

5KP Series — 5000 Watt 30

15KP Series — 15000 Watt 34

20KP Series — 20000 Watt 38

30KP Series — 30000 Watt 40

WLCE Series: Low Capacitance 42

WFC Series 44

P4SMAJ Series — 400 Watt Surface Mount 52

P6SMBJ Series — 600 Watt Surface Mount 58

1.5SMCJ Series — 1500 Watt Surface Mount 64

3.0SMCJ Series — 3000 Watt Surface Mount 70

5.0SMCJ Series — 5000 Watt Surface Mount 76

8SMEJ Series — 8000 Watt Surface Mount 78

PA4SMAJ Series 80

PA6SMBJ Series 84

1.5ASMCJ Series 88

Circuit Examples 92

Applications 93

Transient Voltage Suppression Diodes

World Products, LLC is committed to providing the optimum products for your transient/surge protection problems. Our TVS Diode satisfies the toughest requirements for a low clamping device and provides superior performance in all applications.

World Products expands your options . . . Large selection of equivalents to essentially all TVS Diodes. World Products specifications are designed to provide all of the necessary physical and electrical parameters required for proper component selection.

Discover why the first choice in TVS Diodes is WPI.



General Information

TVS Diode Technology

World Products Transient Voltage Suppression (TVS) Diodes are silicon avalanche devices designed, manufactured, specified and tested according to voltage suppression applications.

These devices, with their fast response and low clamping characteristics, protect all MOS technology based devices, hybrids, and other voltage sensitive components. The low clamping factor and pico-second response time of World Products TVS Diodes clamps transient pulses early and maintains them at an acceptable level for their entire duration. In other overvoltage protection devices, response times are delayed by 24nS to 2 μ s allowing transients to reach dangerous levels. World Products TVS Diodes are designed to meet a 1.30 maximum clamping factor at their rated peak impulse current. This can be compared to clamping factors of 2 to 5 found in other protection devices.

TVS Diode Applications

TVS Diodes are the optimum choice in protecting computer or data processor circuits and power supplies, airframe avionics and controls, numerically controlled machines, telecom circuits, and many other applications. These devices are designed to protect against transient voltages generated by lightning, electro-static discharge (ESD), and inductive switching.

TVS Diode RoHS Compliance

All axial TVS Diodes (no suffix code required) and SMD TVS Diodes (denoted by suffix "F") products purchased from World Products, LLC comply to a maximum concentration value of 0.1% by weight in homogeneous materials for lead (Pb), mercury, hexavalent chromium, polybrominated biphenyls (PBB) and polybrominated diphenyl ethers (PBDE) and of 0.01% weight in homogeneous materials for cadmium and are in compliance with Directive 2002/95/EC of the European Parliament and of the Council of 27 January 2003 on the restriction of the use of certain hazardous substances in electrical and electronic equipment (RoHS Directive).

Note: Lead(Pb) in high-melting point solder for internal connections is not inhibited by RoHS. (i.e. tin-lead solder alloys containing more than 85%)

Selecting the Correct Part Type

The following guidelines should be observed in selecting the correct diode:

TVS Parameters Application Parameters

1. Stand-off Voltage	(VWM)	>=	Operating Voltage	(VOP)
2. Peak Pulse Current	(IPPM)	>=	Source Transient Current	(IS)
3. Clamping Voltage	(VC)	=<	Voltage Withstand	(VWS)

1. If the stand-off voltage is less than the operating voltage of the application, the diode will continually clamp the circuit voltage.
2. The Peak Pulse Current (IPPM) is the maximum current the TVS can handle. The source transient current is determined by dividing the peak transient voltage by the source impedance — this is often difficult to determine. In many cases, however, this may be obtained from industry standard documents, customer requirements, etc.
3. Determine the maximum voltage level that the protected device can withstand (VWS). Select a suppressor which will clamp the transient at a lower level (VC).

Consider the transient source: lightning, electro-static discharge, inductive switching or nuclear explosion (NEMP). Often, a 1500 watt peak pulse rated device will protect against transients due to secondary lightning effects or inductive switching on power, data and telephone lines. A 500 watt device is sufficient to protect sensitive components against transients generated by electro-static discharge.

General Information (continued)

Schematic Symbols

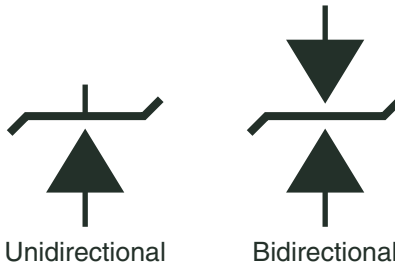

Definitions of Terms

V_c Clamping Voltage:

Peak voltage across the suppressor measured at a specific IPPM. (Note: due to thermal, reactive or other effects, peak voltage and peak current are not necessarily coincident in time.)

IPP Peak Impulse Current:

Peak current measured using a specified waveform.

IPPM Rated Peak Impulse Current:

Rated maximum value of peak impulse current (IPP) applied using a 10 x 1000µs waveform. (Minimum of 10 pulses applied.)

V_{wm} Rated Standoff Voltage:

Maximum working (continuous) DC or peak voltage which may be applied over the standard operating temperature range. (Note: V_{wm} of a selected device must be greater than or equal to the maximum operating voltage of the line to be protected.)

I_d Stand-By Current:

Maximum current that flows through the suppressor at rated standoff voltage (V_{WM}) at a specified temperature.

V_{BR} Breakdown Voltage:

The voltage measured across the suppressor at a specified DC test current (I_T).

I_t Test Current:

The specific DC current applied to the suppressor used to determine breakdown voltage (V_{BR}).

V_{br} Temperature Coefficient:

The ratio of change in breakdown voltage (V_{br}) to changes in temperature. Expressed either as millivolts per degree centigrade (mV/°C) or percent change in breakdown voltage per degree centigrade (%V_{BR}/°C).

CF Clamping Factor:

Ratio of the measured clamping voltage (V_C) at specified peak pulse current (IPP) to breakdown voltage (V_{BR}) on a specific device.

$$CF = \frac{V_C}{V_{BR}}$$

C Capacitance:

Capacitance between the two terminals of a suppressor measured at a specific frequency and bias voltage.

PPPM Rated Multiple Peak Pulse Power:

Derived by multiplying the maximum clamping voltage (V_C) times the Rated Peak Impulse Current (IPPM).

IFSM Rated Forward Surge Current:

Unidirectional devices only. Maximum forward current during a 8.3ms half sine wave of AC line frequency (60Hz).

General Information (continued)

Impulse Current Waveform

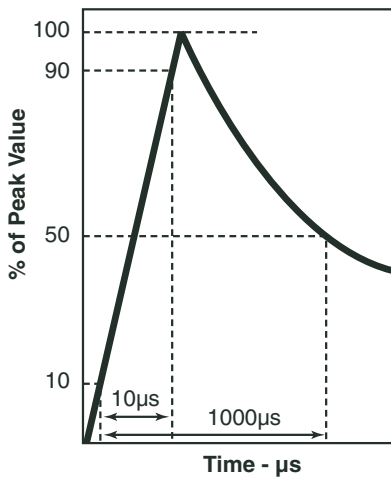

Mechanical Characteristics

Case: UL94V-0 Molded Epoxy

Leads: Tinned Copper

Bending Terminal Leads (Through-hole) Types

When bending the leads, in order to avoid stress to the area where the leads enter the resinous body, use a tool that clamps the point between the package and the bending point. Improper bending will damage the die or separate the resin from the mounting frame, resulting in a degradation in electrical characteristics or a reliability problem such as poor resistance to moisture.

The leads must be bent only once and they should not be bent at an angle of more than 90°C. Leads must be formed before fixing them to a printed circuit board. Never form the leads after soldering.

Recommended distances are:

2mm for P4KE and SA series.

3mm for 1.5KE series.

4mm for 3KP, 5KP, 15KP, 20KP and 30KP series.

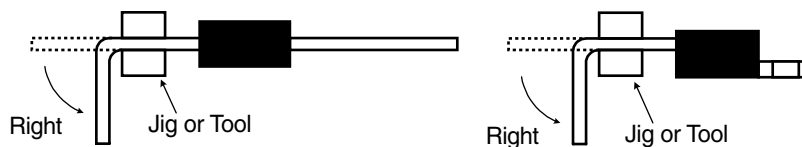

General Information (continued)

Solderability

Military Standard 202G Method 208H

Heat Resistance of Solder

Standard Temperature Profile for Lead Solder (Sn-Pb eutectic)

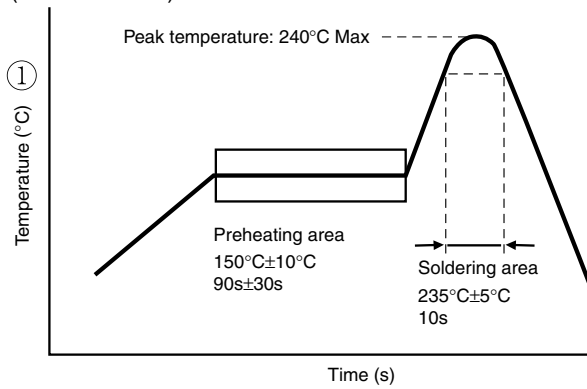

Standard Temperature Profile for Lead-free Solder

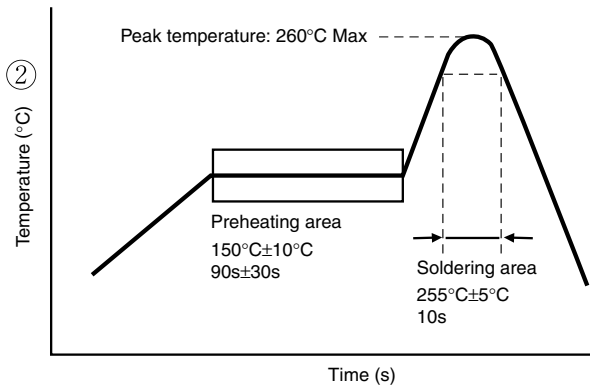

Note: For Lead-free solder, the maximum temperature during mounting processes will be 260°C for both re-flow and flow soldering processes.

Soldering of Through-hole Mounting Devices

Resistance to soldering heat test is carried out under the condition shown below. Soldering should be completed at a lowest possible temperature for a shortest period.

Temp. 260 ± 5°C
Duration 10 ± 1s

General requirements for manual soldering are as follows:

- Use a soldering iron of 30 watts maximum, that is grounded or with a high insulation resistance.
- The iron tip is kept away from any resinous body.
- Attachment should be achieved in not more than 3 seconds.

Be sure again not to put an excessive mechanical stress on devices, such as a rough insertion of device into a throughhole, or manual reforming of leads after soldering.

Axial Lead Devices

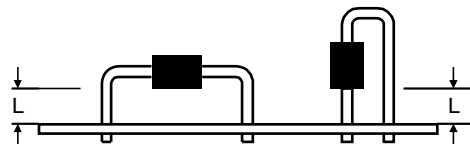
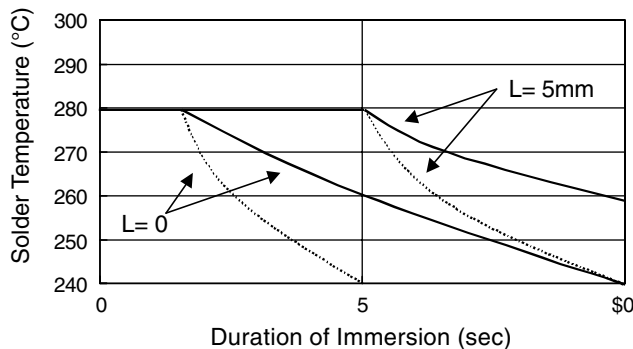

General Information (continued)

Preformed Lead Drawings

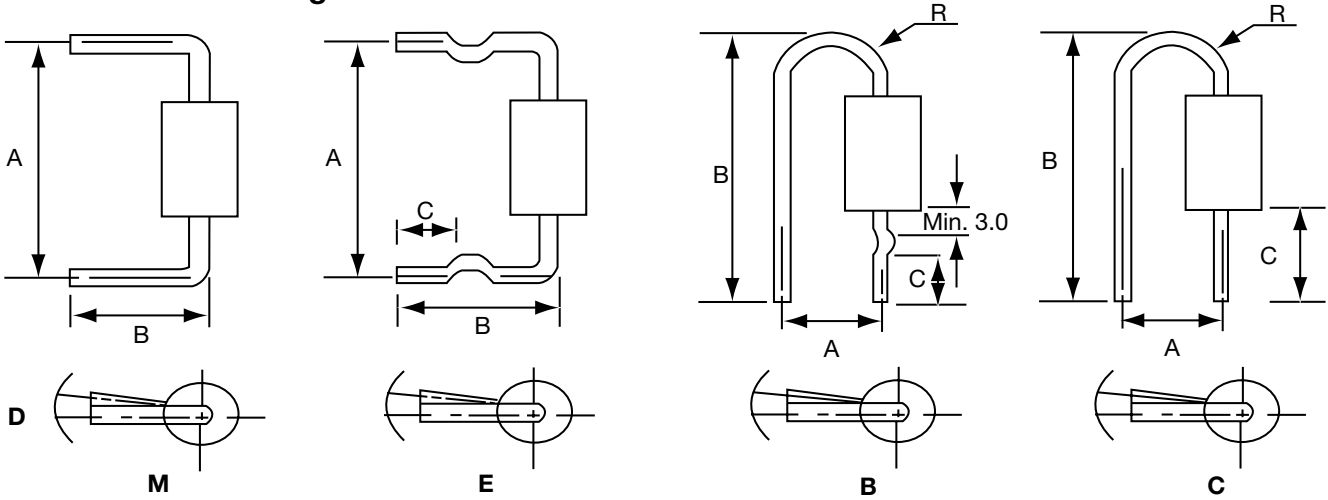

Case type	Preformed type	A (mm)		B (mm)		C (mm)		D (mm)		R (mm)	
		Range	Tolerance	Range	Tolerance	Range	Tolerance	Range	Tolerance	Range	Tolerance
DO-41 package P4KE Series	M	11~20	±0.5	8~20	±0.5	---	---	1.5	max.	---	---
	E	11~20	±0.5	11~16	±1.0	4~5	±0.5	1.5	max.	---	---
	B	7.5	±0.5	19~22	±0.5	7.5	±0.5	1.5	max.	2.5~4	typ.
	C	4.5	±0.8	18~19	±0.5	9.0	±0.5	1.5	max.	2.5~4	typ.
DO-15 package SA Series P6KE Series	M	13~20	±0.5	8~22	±0.5	---	---	1.5	max.	---	---
	E	13~20	±0.5	11~16	±1.0	4~5	±0.5	1.5	max.	---	---
DO-201AD package 1.5KE Series	M	15~20	±1.0	8~22	±1.0	---	---	2.0	max.	---	---
	E	15~20	±1.0	10~22	±1.0	3~5	±0.5	2.0	max.	---	---
R-6 package 3KP Series 5KP Series 15KP Series	M	15~20	±1.0	8~22	±1.0	---	---	2.0	max.	---	---
20KP Series 30KP Series	M	15~20	±1.0	8~22	±1.0	---	---	2.0	max.	---	---

Part Marking

For Surface Mount Devices

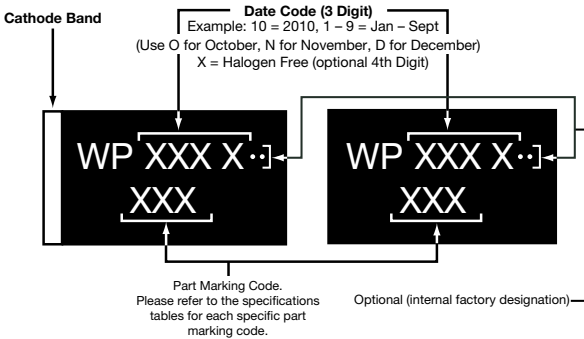

For Axial Lead

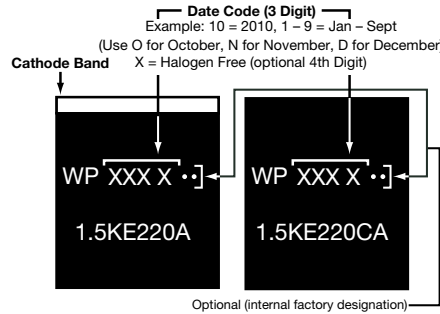

For WFC Series Types

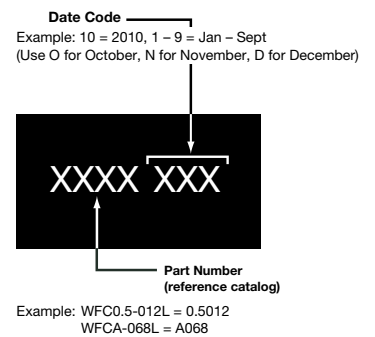

General Information (continued)

Part Numbering System

Axial Type

Example Part Number:

P4KE	20	C	A	Z	TR	-	X
(1)	(2)	(3)	(4)	(5)	(6)		(7)

- (1) Series:** P4KE = 400 Watt
SA = 500 Watt
P6KE = 600 Watt
1.5KE = 1500 Watt
3KP = 3000 Watt
5KP = 5000 Watt
15KP = 15000 Watt
20KP = 20000 Watt
30KP = 30000 Watt
- (2) Voltage:** 20 = 20V
Nominal Breakdown Voltage For P4KE, P6KE, 1.5KE
Rated Standoff Voltage For SA, 3KP, 5KP, 15KP, 20KP, 30KP
- (3) Polarity:** Blank = Unidirectional
C = Bidirectional
- (4) Tolerance:** Blank = 10%
A = 5%
- (5) AEC-Q101:** Z (where applicable)
- (6) Packaging:** Blank = Bulk
TR = Tape and Reel
- (7) Halogen Free** X = Halogen Free

Notes: All Axial Types are RoHS compliant.

Surface Mount Type

Example Part Number:

P4SMAJ	20	C	A	Z	F	-	X
(1)	(2)	(3)	(4)	(5)	(6)		(7)

- (1) Series:** P4SMAJ = 400 Watt Surface Mount
(6) Halogen Free
P6SMBJ = 600 Watt Surface Mount
X = Halogen Free
1.5SMCJ = 1500 Watt Surface Mount
3.0SMCJ = 3000 Watt Surface Mount
5.0SMCJ = 5000 Watt Surface Mount
- (2) Rated Stand-Off Voltage:** 20 = 20V
- (3) Polarity:** Blank = Unidirectional
C = Bidirectional
- (4) Tolerance:** Blank = 10%
A = 5%
- (5) AEC-Q101:** Z (where applicable)
- (6) RoHS Compliance:** Blank: No Compliance
F: RoHS Compliance
- (7) Halogen Free** X = Halogen Free

WFC Type

Refer to complete part number as stated in this catalog on pages 46 - 48.

All WFC Series parts are RoHS compliant and Halogen Free.

P4KE Series – 400 Watt



P4KE Series Features

- RoHS Compliance Standard
- 400 watt peak pulse power dissipation
- Available in voltages from 6.8V to 550V
- Unidirectional and Bidirectional
- Glass passivated junction
- Low clamping factor
- Available in bulk or tape and reel (Reel quantity = 5,000 pieces)
- Each device 100% surge tested
- Tape and Reel to EIA Standard RS-296-E
- UL 497B Recognized, File #E135015
- AEC-Q101 Qualified (11A & 11CA – 550A & 550CA) types. (When ordering ADD suffix “Z” to end of part number.)

Absolute Maximum Ratings

Parameter	Value
Peak pulse power dissipation (PPPM) at 25°C	400W
Steady state power dissipation at lead temperature = 75°C (Lead length 3/8” min.)	1W
Operating and storage temperatures	-65°C to + 175°C

Mechanical Dimensions

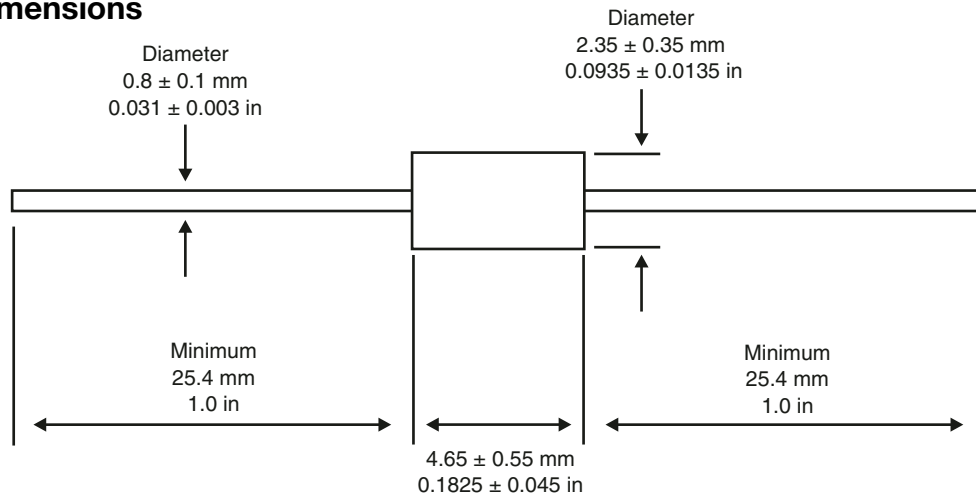

Standard Mounting Pad Layout

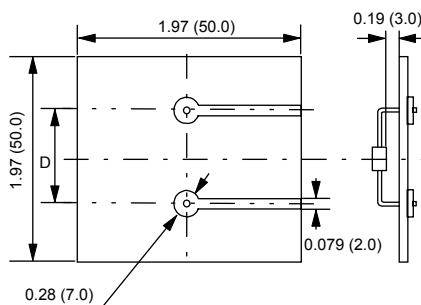

NOTE: **Dimension D**
 a.) P4KE (DO-41 Package) - 0.362 (9.2)
 b.) SA / P6KE (DO-15 Package) - 0.437 (11.6)
Hole Diameter
 a.) 0.044 (1.1)

All dimensions in inches and (millimeters)

P4KE Series – 400 Watt (continued)**Electrical Characteristics**

Part Number*	Rated Standoff Voltage	Breakdown Voltage			Maximum Stand By Current @VWM+ Id	10/1000 μ s Maximum Clamping Voltage @Ippm# Vc Max	10/1000 μ s Rated Peak Impulse Current Ippm#
		Vbr (Volts)		@It			
	Vwm (Volts)	Min	Max	(mA)	(μ A)	(Volts)	(Amperes)
P4KE6.8	5.50	6.12	7.48	10	1000	10.8	38.0
P4KE6.8A	5.80	6.45	7.14	10	1000	10.5	39.0
P4KE7.5	6.05	6.75	8.25	10	500	11.7	36.0
P4KE7.5A	6.40	7.13	7.88	10	500	11.3	36.3
P4KE8.2	6.63	7.38	9.02	10	200	12.5	33.0
P4KE8.2A	7.02	7.79	8.61	10	200	12.1	33.9
P4KE9.1	7.37	8.19	10.00	1	50	13.8	30.0
P4KE9.1A	7.78	8.65	9.55	1	50	13.4	30.6
P4KE10	8.10	9.00	11.00	1	10	15.0	28.0
P4KE10A	8.55	9.50	10.50	1	10	14.5	28.3
P4KE11	8.92	9.90	12.10	1	5	16.2	26.0
P4KE11A	9.40	10.50	11.60	1	5	15.6	26.3
P4KE12	9.72	10.80	13.20	1	5	17.3	24.0
P4KE12A	10.20	11.40	12.60	1	5	16.7	24.6
P4KE13	10.50	11.70	14.30	1	1	19.0	22.0
P4KE13A	11.10	12.40	13.70	1	1	18.2	22.5
P4KE15	12.10	13.50	16.50	1	1	22.0	19.0
P4KE15A	12.80	14.30	15.80	1	1	21.2	19.3
P4KE16	12.90	14.40	17.60	1	1	23.5	18.0
P4KE16A	13.60	15.20	16.80	1	1	22.5	18.2
P4KE18	14.50	16.20	19.80	1	1	26.5	16.0
P4KE18A	15.30	17.10	18.90	1	1	25.2	16.1
P4KE20	16.20	18.00	22.00	1	1	29.1	14.0
P4KE20A	17.10	19.00	21.00	1	1	27.7	14.8
P4KE22	17.80	19.80	24.20	1	1	31.9	13.0
P4KE22A	18.80	20.90	23.10	1	1	30.6	13.4
P4KE24	19.40	21.60	26.40	1	1	34.7	12.0
P4KE24A	20.50	22.80	25.20	1	1	33.2	12.3
P4KE27	21.80	24.30	29.70	1	1	39.1	11.0
P4KE27A	23.10	25.70	28.40	1	1	37.5	10.9

* = Add "C" or "CA" suffix for bidirectional device types.

+ = For Bidirectional Types Having VWM \leq 10V, their ID limit is doubled.

= See General Information for Impulse Current Waveform.

P4KE Series – 400 Watt (continued)**Electrical Characteristics (continued)**

Part Number*	Rated Standoff Voltage	Breakdown Voltage			Maximum Stand By Current @VWM+ Id	10/1000µs Maximum Clamping Voltage @Ippm# Vc Max	10/1000µs Rated Peak Impulse Current Ippm#
		Vbr (Volts)		@It			
	Vwm (Volts)	Min	Max	(mA)	(µA)	(Volts)	(Amperes)
P4KE30	24.30	27.00	33.00	1	1	43.5	10.0
P4KE30A	25.60	28.50	31.50	1	1	41.4	9.9
P4KE33	26.80	29.70	36.30	1	1	47.7	9.0
P4KE33A	28.20	31.40	34.70	1	1	45.7	9.0
P4KE36	29.10	32.40	39.60	1	1	52.0	8.0
P4KE36A	30.80	34.20	37.80	1	1	49.9	8.2
P4KE39	31.60	35.10	42.90	1	1	56.4	7.4
P4KE39A	33.30	37.10	41.00	1	1	53.9	7.6
P4KE43	34.80	38.70	47.30	1	1	61.9	6.8
P4KE43A	36.80	40.90	45.20	1	1	59.3	6.9
P4KE47	38.10	42.30	51.70	1	1	67.8	6.2
P4KE47A	40.20	44.70	49.40	1	1	64.8	6.3
P4KE51	41.30	45.90	56.10	1	1	73.5	5.7
P4KE51A	43.60	48.50	53.60	1	1	70.1	5.8
P4KE56	45.60	50.40	61.60	1	1	80.5	5.2
P4KE56A	47.80	53.20	58.80	1	1	77.0	5.3
P4KE62	50.20	55.80	68.20	1	1	89.0	4.7
P4KE62A	53.00	58.90	65.10	1	1	85.0	4.8
P4KE68	55.10	61.20	74.80	1	1	98.0	4.3
P4KE68A	58.10	64.60	71.40	1	1	92.0	4.5
P4KE75	60.70	67.50	82.50	1	1	108.0	3.9
P4KE75A	64.10	71.30	78.80	1	1	103.0	4.0
P4KE82	66.40	73.80	90.20	1	1	118.0	3.6
P4KE82A	70.10	77.90	86.10	1	1	113.0	3.6
P4KE91	73.70	81.90	100.00	1	1	131.0	3.2
P4KE91A	77.80	86.50	95.50	1	1	125.0	3.3
P4KE100	81.00	90.00	110.00	1	1	144.0	2.9
P4KE100A	85.50	95.00	105.00	1	1	137.0	3.0
P4KE110	89.20	99.90	121.00	1	1	158.0	2.7
P4KE110A	94.00	105.00	116.00	1	1	152.0	2.7

* = Add "C" or "CA" suffix for bidirectional device types.

+ = For Bidirectional Types Having VWM <= 10V, their ID limit is doubled.

= See General Information for Impulse Current Waveform.

P4KE Series – 400 Watt (continued)**Electrical Characteristics (continued)**

Part Number*	Rated Standoff Voltage	Breakdown Voltage			Maximum Stand By Current @VWM+ Id	10/1000 μ s Maximum Clamping Voltage @Ippm# Vc Max	10/1000 μ s Rated Peak Impulse Current Ippm#
		Vbr (Volts)		@It			
	Vwm (Volts)	Min	Max	(mA)	(μ A)	(Volts)	(Amperes)
P4KE120	97.20	108.00	132.00	1	1	173.0	2.4
P4KE120A	102.00	114.00	126.00	1	1	165.0	2.5
P4KE130	105.00	117.00	143.00	1	1	187.0	2.2
P4KE130A	111.00	124.00	137.00	1	1	179.0	2.3
P4KE150	121.00	135.00	165.00	1	1	215.0	2.0
P4KE150A	128.00	143.00	158.00	1	1	207.0	2.0
P4KE160	130.00	144.00	176.00	1	1	230.0	1.8
P4KE160A	136.00	152.00	168.00	1	1	219.0	1.9
P4KE170	138.00	153.00	187.00	1	1	244.0	1.7
P4KE170A	145.00	162.00	179.00	1	1	234.0	1.8
P4KE180	146.00	162.00	198.00	1	1	258.0	1.6
P4KE180A	154.00	171.00	189.00	1	1	246.0	1.7
P4KE200	162.00	180.00	220.00	1	1	287.0	1.5
P4KE200A	171.00	190.00	210.00	1	1	274.0	1.5
P4KE220	175.00	198.00	242.00	1	1	344.0	1.16
P4KE220A	185.00	209.00	231.00	1	1	328.0	1.3
P4KE250	202.00	225.00	275.00	1	1	360.0	1.10
P4KE250A	214.00	237.00	263.00	1	1	344.0	1.2
P4KE300	243.00	270.00	330.00	1	1	430.0	0.93
P4KE300A	256.00	285.00	315.00	1	1	414.0	1.0
P4KE350	284.00	315.00	385.00	1	1	504.0	0.79
P4KE350A	300.00	332.00	368.00	1	1	482.0	0.85
P4KE400	324.00	360.00	440.00	1	1	574.0	0.70
P4KE400A	342.00	380.00	420.00	1	1	548.0	0.75
P4KE440	356.00	396.00	484.00	1	1	631.0	0.66
P4KE440A	376.00	418.00	462.00	1	1	602.0	0.68
P4KE480A	408.00	456.00	504.00	1	1	658.0	0.61
P4KE510A	434.00	485.00	535.00	1	1	698.0	0.57
P4KE530A	450.00	503.50	556.50	1	1	725.0	0.55
P4KE540A	459.00	513.00	567.00	1	1	740.0	0.54
P4KE550A	467.00	522.50	577.50	1	1	760.0	0.52

* = Add "C" or "CA" suffix for bidirectional device types.

+ = For Bidirectional Types Having VWM <= 10V, their ID limit is doubled.

= See General Information for Impulse Current Waveform.

SA Series – 500 Watt



SA Series Features

- RoHS Compliance Standard
- 500 watt peak pulse power dissipation
- Available in voltages from 5.0V to 170V
- Unidirectional and Bidirectional
- Glass passivated junction
- Low clamping factor
- Available in bulk or tape and reel (Reel quantity = 4,000 pieces)
- Each device 100% surge tested
- Tape and Reel to EIA Standard RS-296-E
- UL 497B Recognized, File #E135015

Absolute Maximum Ratings

Parameter	Value
Peak pulse power dissipation (PPPM) at 25°C	500W
Steady state power dissipation at lead temperature = 75°C (Lead length 3/8" min.)	1W
Operating and storage temperatures	-55°C to + 175°C

Mechanical Dimensions

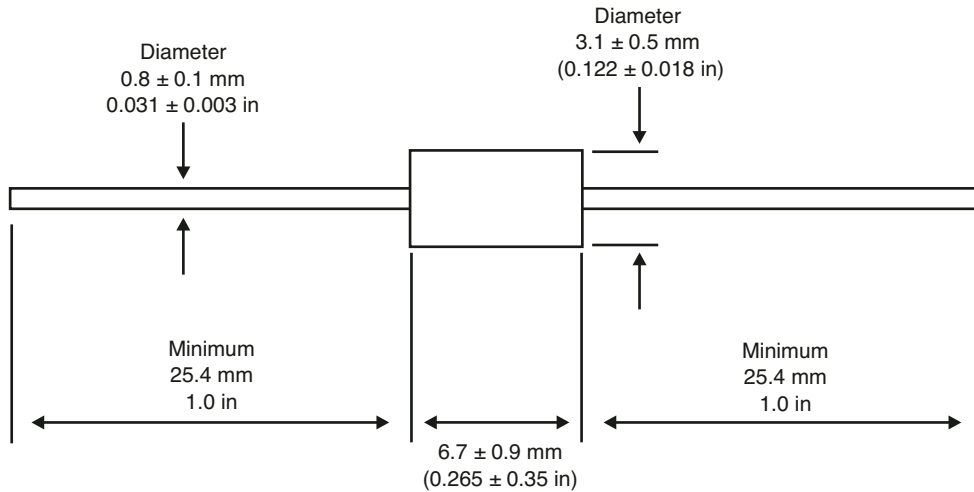

Standard Mounting Pad Layout

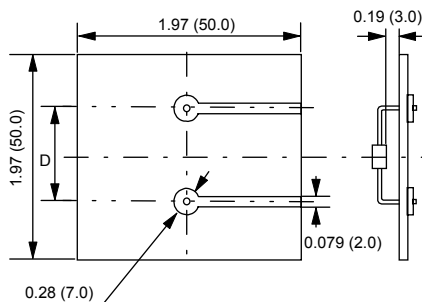

NOTE: **Dimension D**
 a.) P4KE (DO-41 Package) - 0.362 (9.2)
 b.) SA / P6KE (DO-15 Package) - 0.437 (11.6)
Hole Diameter
 a.) 0.044 (1.1)

All dimensions in inches and (millimeters)

SA Series – 500 Watt (continued)

Electrical Characteristics

Part Number*	Rated Standoff Voltage	Breakdown Voltage			Maximum Stand By Current @VWM+ Id	10/1000µs Maximum Clamping Voltage @Ippm# Vc Max	10/1000µs Rated Peak Impulse Current Ippm#
		Vbr (Volts)		@It			
	Vwm (Volts)	Min	Max	(mA)	(µA)	(Volts)	(Amperes)
SA5.0	5.0	6.40	7.30	10	600	9.6	52.0
SA5.0A	5.0	6.40	7.00	10	600	9.2	55.4
SA6.0	6.0	6.67	8.15	10	600	11.4	43.9
SA6.0A	6.0	6.67	7.37	10	600	10.3	49.5
SA6.5	6.5	7.22	8.82	10	400	12.3	40.7
SA6.5A	6.5	7.22	7.98	10	400	11.2	45.5
SA7.0	7.0	7.78	9.51	10	150	13.3	37.8
SA7.0A	7.0	7.78	8.60	10	150	12.0	42.5
SA7.5	7.5	8.33	10.2	1	50	14.3	35.0
SA7.5A	7.5	8.33	9.21	1	50	12.9	39.5
SA8.0	8.0	8.89	10.9	1	25	15.0	33.3
SA8.0A	8.0	8.89	9.83	1	25	13.6	37.5
SA8.5	8.5	9.44	11.5	1	10	15.9	31.4
SA8.5A	8.5	9.44	10.4	1	10	14.4	35.4
SA9.0	9.0	10.0	12.2	1	5	16.9	29.5
SA9.0A	9.0	10.0	11.1	1	5	15.4	33.1
SA10	10	11.1	13.6	1	3	18.8	26.6
SA10A	10	11.1	12.3	1	3	17.0	30.0
SA11	11	12.2	14.9	1	1	20.1	24.9
SA11A	11	12.2	13.5	1	1	18.2	28.0
SA12	12	13.3	16.3	1	1	22.0	22.7
SA12A	12	13.3	14.7	1	1	19.9	25.6
SA13	13	14.4	17.6	1	1	23.8	21.0
SA13A	13	14.4	15.9	1	1	21.5	23.7
SA14	14	15.6	19.1	1	1	25.8	19.4
SA14A	14	15.6	17.2	1	1	23.2	22.0

* = Add "C" or "CA" suffix for bidirectional device types.

+ = For Bidirectional Types Having VWM <= 10V, their ID limit is doubled.

= See General Information for Impulse Current Waveform.

SA Series – 500 Watt (continued)**Electrical Characteristics (continued)**

Part Number*	Rated Standoff Voltage	Breakdown Voltage			Maximum Stand By Current @VWM+ Id	10/1000µs Maximum Clamping Voltage @Ippm# Vc Max	10/1000µs Rated Peak Impulse Current Ippm#
		Vbr (Volts)		@It			
	Vwm (Volts)	Min	Max	(mA)	(µA)	(Volts)	(Amperes)
SA15	15	16.7	20.4	1	1	26.9	18.8
SA15A	15	16.7	18.5	1	1	24.4	20.9
SA16	16	17.8	21.8	1	1	28.8	17.6
SA16A	16	17.8	19.7	1	1	26.0	19.6
SA17	17	18.9	23.1	1	1	30.5	16.4
SA17A	17	18.9	20.9	1	1	27.6	18.5
SA18	18	20.0	24.4	1	1	32.2	15.5
SA18A	18	20.0	22.1	1	1	29.2	17.5
SA20	20	22.2	27.1	1	1	35.8	13.9
SA20A	20	22.2	24.5	1	1	32.4	15.7
SA22	22	24.4	29.8	1	1	39.4	12.7
SA22A	22	24.4	26.9	1	1	35.5	14.4
SA24	24	26.7	32.6	1	1	43.0	11.6
SA24A	24	26.7	29.5	1	1	38.9	13.1
SA26	26	28.9	35.3	1	1	46.6	10.7
SA26A	26	28.9	31.9	1	1	42.1	12.1
SA28	28	31.1	38.0	1	1	50.0	9.9
SA28A	28	31.1	34.4	1	1	45.4	11.2
SA30	30	33.3	40.7	1	1	53.5	9.3
SA30A	30	33.3	36.8	1	1	48.4	10.5
SA33	33	36.7	44.9	1	1	59.0	8.5
SA33A	33	36.7	40.6	1	1	53.3	9.6
SA36	36	40.0	48.9	1	1	64.3	7.8
SA36A	36	40.0	44.2	1	1	58.1	8.8
SA40	40	44.4	54.3	1	1	71.4	7.0
SA40A	40	44.4	49.1	1	1	64.5	7.9

* = Add "C" or "CA" suffix for bidirectional device types.

+ = For Bidirectional Types Having VWM <= 10V, their ID limit is doubled.

= See General Information for Impulse Current Waveform.

SA Series – 500 Watt (continued)**Electrical Characteristics (continued)**

Part Number*	Rated Standoff Voltage	Breakdown Voltage			Maximum Stand By Current @VWM+ Id	10/1000µs Maximum Clamping Voltage @Ippm# Vc Max	10/1000µs Rated Peak Impulse Current Ippm#
		Vbr (Volts)		@It			
	Vwm (Volts)	Min	Max	(mA)	(µA)	(Volts)	(Amperes)
SA43	43	47.8	58.4	1	1	76.7	6.5
SA43A	43	47.8	52.8	1	1	69.4	7.3
SA45	45	50.0	61.1	1	1	80.3	6.2
SA45A	45	50.0	55.3	1	1	72.7	7.0
SA48	48	53.3	65.1	1	1	85.5	5.8
SA48A	48	53.3	58.9	1	1	77.4	6.6
SA51	51	56.7	69.3	1	1	91.1	5.5
SA51A	51	56.7	62.7	1	1	82.4	6.2
SA54	54	60.0	73.3	1	1	96.3	5.2
SA54A	54	60.0	66.3	1	1	87.1	5.9
SA58	58	64.4	78.7	1	1	103.0	4.9
SA58A	58	64.4	71.2	1	1	93.6	5.4
SA60	60	66.7	81.5	1	1	107.0	4.7
SA60A	60	66.7	73.7	1	1	96.8	5.3
SA64	64	71.1	86.9	1	1	114.0	4.4
SA64A	64	71.1	78.6	1	1	103.0	5.0
SA70	70	77.8	95.1	1	1	125.0	4.0
SA70A	70	77.8	86.0	1	1	113.0	4.5
SA75	75	83.3	102.0	1	1	134.0	3.7
SA75A	75	83.3	92.1	1	1	121.0	4.2
SA78	78	86.7	106.0	1	1	139.0	3.6
SA78A	78	86.7	95.8	1	1	126.0	4.0
SA85	85	94.4	115.0	1	1	151.0	3.3
SA85A	85	94.4	104.0	1	1	137.0	3.7
SA90	90	100	122.0	1	1	160.0	3.1
SA90A	90	100	111.0	1	1	146.0	3.5

* = Add "C" or "CA" suffix for bidirectional device types.

+ = For Bidirectional Types Having VWM <= 10V, their ID limit is doubled.

= See General Information for Impulse Current Waveform.

SA Series – 500 Watt (continued)**Electrical Characteristics (continued)**

Part Number*	Rated Standoff Voltage	Breakdown Voltage			Maximum Stand By Current @VWM+ Id	10/1000µs Maximum Clamping Voltage @Ippm# Vc Max	10/1000µs Rated Peak Impulse Current Ippm#
		Vbr (Volts)		@It			
	Vwm (Volts)	Min	Max	(mA)	(µA)	(Volts)	(Amperes)
SA100	100	111	136.0	1	1	179.9	2.8
SA100A	100	111	123.0	1	1	162.0	3.1
SA110	110	122	149.0	1	1	196.0	2.6
SA110A	110	122	135.0	1	1	177.0	2.9
SA120	120	133	163.0	1	1	214.0	2.3
SA120A	120	133	147.0	1	1	193.0	2.6
SA130	130	144	176.0	1	1	231.0	2.2
SA130A	130	144	159.0	1	1	209.0	2.4
SA150	150	167	204.0	1	1	268.0	1.9
SA150A	150	167	185.0	1	1	243.0	2.1
SA160	160	178	218.0	1	1	287.0	1.7
SA160A	160	178	197.0	1	1	259.0	2.0
SA170	170	189	231.0	1	1	304.0	1.6
SA170A	170	189	209.0	1	1	275.0	1.9
SA180A	180	201	222.0	1	1	292.0	1.7
SA190A	190	211	233.0	1	1	308.0	1.6
SA200A	200	224	247.0	1	1	324.0	1.5
SA210A	210	237	263.0	1	1	340.0	1.5
SA220A	220	246	272.0	1	1	356.0	1.4

* = Add "C" or "CA" suffix for bidirectional device types.

+ = For Bidirectional Types Having VWM <= 10V, their ID limit is doubled.

= See General Information for Impulse Current Waveform.



P6KE Series – 600 Watt



P6KE Series Features

- RoHS Compliance Standard
- 600 watt peak pulse power dissipation
- Available in voltages from 6.8V to 600V
- Unidirectional and Bidirectional
- Glass passivated junction
- Low clamping factor
- Available in bulk or tape and reel (Reel quantity = 4,000 pieces)
- Each device 100% surge tested
- Tape and Reel to EIA Standard RS-296-E
- UL 497B Recognized, File # E135015
- AEC-Q101 Qualified (11A & 11CA – 600A & 600CA) types. (When ordering ADD suffix “Z” to end of part number.)

Absolute Maximum Ratings

Parameter	Value
Peak pulse power dissipation (PPPM) at 25°C	600W
Steady state power dissipation at lead temperature = 75°C (Lead length 3/8” min.)	5W
Operating and storage temperatures	-55°C to + 175°C

Mechanical Dimensions

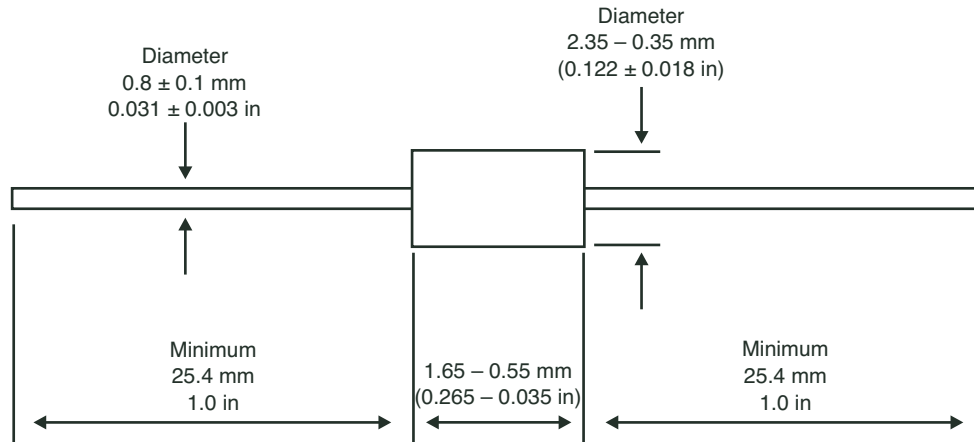

Standard Mounting Pad Layout

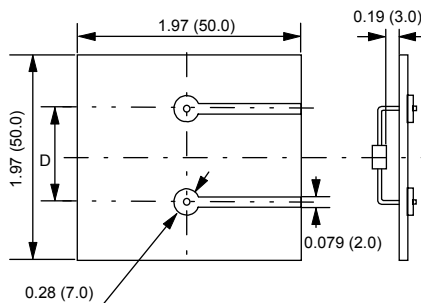

NOTE: **Dimension D**
 a.) P4KE (DO-41 Package) - 0.362 (9.2)
 b.) SA / P6KE (DO-15 Package) - 0.437 (11.6)
Hole Diameter
 a.) 0.044 (1.1)

All dimensions in inches and (millimeters)

P6KE Series – 600 Watt (continued)**Electrical Characteristics**

Part Number*	Rated Standoff Voltage	Breakdown Voltage			Maximum Stand By Current @VWM+ Id	10/1000 μ s Maximum Clamping Voltage @Ippm# Vc Max	10/1000 μ s Rated Peak Impulse Current Ippm#
		Vbr (Volts)		@It			
	Vwm (Volts)	Min	Max	(mA)	(μ A)	(Volts)	(Amperes)
P6KE6.8	5.50	6.12	7.48	10	1000	10.8	56
P6KE6.8A	5.80	6.45	7.14	10	1000	10.5	58.1
P6KE7.5	6.05	6.75	8.25	10	500	11.7	51
P6KE7.5A	6.40	7.13	7.88	10	500	11.3	54
P6KE8.2	6.63	7.38	9.02	10	200	12.5	48
P6KE8.2A	7.02	7.79	8.61	10	200	12.1	50.4
P6KE9.1	7.37	8.19	10.0	1	50	13.8	44
P6KE9.1A	7.78	8.65	9.55	1	50	13.4	45.5
P6KE10	8.10	9.00	11.0	1	10	15.0	40
P6KE10A	8.55	9.5	10.5	1	10	14.5	42.1
P6KE11	8.92	9.9	12.1	1	5	16.2	37
P6KE11A	9.40	10.5	11.6	1	5	15.6	39.1
P6KE12	9.72	10.8	13.2	1	5	17.3	35
P6KE12A	10.2	11.4	12.6	1	5	16.7	36.5
P6KE13	10.5	11.7	14.3	1	1	19.0	32
P6KE13A	11.1	12.4	13.7	1	1	18.2	33.5
P6KE15	12.1	13.5	16.5	1	1	22.0	27
P6KE15A	12.8	14.3	15.8	1	1	21.2	28.8
P6KE16	12.9	14.4	17.6	1	1	23.5	26
P6KE16A	13.6	15.2	16.8	1	1	22.5	27.1
P6KE18	14.5	16.2	19.8	1	1	26.5	23
P6KE18A	15.3	17.1	18.9	1	1	25.2	24.2
P6KE20	16.2	18.0	22.0	1	1	29.1	21
P6KE20A	17.1	19.0	21.0	1	1	27.7	22
P6KE22	17.8	19.8	24.2	1	1	31.9	19
P6KE22A	18.8	20.9	23.1	1	1	30.6	19.9
P6KE24	19.4	21.6	26.4	1	1	34.7	17
P6KE24A	20.5	22.8	25.2	1	1	33.2	18.4
P6KE27	21.8	24.3	29.7	1	1	39.1	15
P6KE27A	23.1	25.7	28.4	1	1	37.5	16.3

* = Add "C" or "CA" suffix for bidirectional device types.

+ = For Bidirectional Types Having VWM \leq 10V, their ID limit is doubled.

= See General Information for Impulse Current Waveform.

P6KE Series – 600 Watt (continued)**Electrical Characteristics (continued)**

Part Number*	Rated Standoff Voltage	Breakdown Voltage			Maximum Stand By Current @VWM+ Id	10/1000µs Maximum Clamping Voltage @Ippm# Vc Max	10/1000µs Rated Peak Impulse Current Ippm#
		Vbr (Volts)		@It			
	Vwm (Volts)	Min	Max	(mA)	(µA)	(Volts)	(Amperes)
P6KE30	24.3	27.0	33.0	1	1	43.5	14
P6KE30A	25.6	28.5	31.5	1	1	41.4	14.7
P6KE33	26.8	29.7	36.3	1	1	47.7	12.6
P6KE33A	28.2	31.4	34.7	1	1	45.7	13.3
P6KE36	29.1	32.4	39.6	1	1	52.0	11.6
P6KE36A	30.8	34.2	37.8	1	1	49.9	12.2
P6KE39	31.6	35.1	42.9	1	1	56.4	10.5
P6KE39A	33.3	37.1	41.0	1	1	53.9	11.3
P6KE43	34.8	38.7	47.3	1	1	61.9	9.6
P6KE43A	36.8	40.9	45.2	1	1	59.3	10.3
P6KE47	38.1	42.3	51.7	1	1	67.8	8.9
P6KE47A	40.2	44.7	49.4	1	1	64.8	9.4
P6KE51	41.3	45.9	56.1	1	1	73.5	8.2
P6KE51A	43.6	48.5	53.6	1	1	70.1	8.7
P6KE56	45.4	50.4	61.6	1	1	80.5	7.4
P6KE56A	47.8	53.2	58.8	1	1	77.0	7.9
P6KE62	50.2	55.8	68.2	1	1	89.0	6.8
P6KE62A	53.0	58.9	65.1	1	1	85.0	7.2
P6KE68	55.1	61.2	74.8	1	1	98.0	6.1
P6KE68A	58.1	64.6	71.4	1	1	92.0	6.6
P6KE75	60.7	67.5	82.5	1	1	108.0	5.5
P6KE75A	64.1	71.3	78.8	1	1	103.0	5.9
P6KE82	66.4	73.8	90.2	1	1	118.0	5.1
P6KE82A	70.1	77.9	86.1	1	1	113.0	5.4
P6KE91	73.7	81.9	100.0	1	1	131.0	4.5
P6KE91A	77.8	86.5	95.5	1	1	125.0	4.9
P6KE100	81.0	90.0	110.0	1	1	144.0	4.2
P6KE100A	85.5	95.0	105.0	1	1	137.0	4.5
P6KE110	89.2	99.0	121.0	1	1	158.0	3.8
P6KE110A	94.0	105.0	116.0	1	1	152.0	4.0

* = Add "C" or "CA" suffix for bidirectional device types.

+ = For Bidirectional Types Having VWM <= 10V, their ID limit is doubled.

= See General Information for Impulse Current Waveform.

P6KE Series – 600 Watt (continued)**Electrical Characteristics (continued)**

Part Number*	Rated Standoff Voltage	Breakdown Voltage			Maximum Stand By Current @VWM+ Id	10/1000µs Maximum Clamping Voltage @Ippm# Vc Max	10/1000µs Rated Peak Impulse Current Ippm#
		Vbr (Volts)		@It			
	Vwm (Volts)	Min	Max	(mA)	(µA)	(Volts)	(Amperes)
P6KE120	97.2	108.0	132.0	1	1	173.0	3.5
P6KE120A	102.0	114.0	126.0	1	1	165.0	3.7
P6KE130	105.0	117.0	143.0	1	1	187.0	3.2
P6KE130A	111.0	124.0	137.0	1	1	179.0	3.4
P6KE150	121.0	135.0	165.0	1	1	215.0	2.8
P6KE150A	128.0	143.0	158.0	1	1	207.0	2.9
P6KE160	130.0	144.0	176.0	1	1	230.0	2.6
P6KE160A	136.0	152.0	168.0	1	1	219.0	2.8
P6KE170	138.0	153.0	187.0	1	1	244.0	2.5
P6KE170A	145.0	162.0	179.0	1	1	234.0	2.6
P6KE180	146.0	162.0	198.0	1	1	258.0	2.3
P6KE180A	154.0	171.0	189.0	1	1	246.0	2.5
P6KE200	162.0	180.0	220.0	1	1	287.0	2.1
P6KE200A	171.0	190.0	210.0	1	1	274.0	2.2
P6KE220	175.0	198.0	242.0	1	1	344.0	1.75
P6KE220A	185.0	209.0	231.0	1	1	328.0	1.9
P6KE250	202.0	225.0	275.0	1	1	360.0	1.67
P6KE250A	214.0	237.0	263.0	1	1	344.0	1.8
P6KE300	243.0	270.0	330.0	1	1	430.0	1.40
P6KE300A	256.0	285.0	315.0	1	1	414.0	1.5
P6KE350	284.0	315.0	385.0	1	1	504.0	1.20
P6KE350A	300.0	332.0	368.0	1	1	482.0	1.3
P6KE400	324.0	360.0	440.0	1	1	574.0	1.05
P6KE400A	342.0	380.0	420.0	1	1	548.0	1.10
P6KE440	356.0	396.0	484.0	1	1	631.0	0.99
P6KE440A	376.0	418.0	462.0	1	1	602.0	1.04
P6KE480A	408.0	456.0	504.0	1	1	658.0	0.90
P6KE510A	434.0	485.0	535.0	1	1	698.0	0.90
P6KE530A	450.0	503.5	556.50	1	1	725.0	0.80
P6KE540A	459.0	513.0	567.0	1	1	740.0	0.80
P6KE550A	467.5	522.5	577.5	1	1	760.0	0.80
P6KE600A	512.0	570.0	630.0	1	1	828.0	0.75

* = Add "C" or "CA" suffix for bidirectional device types.

+ = For Bidirectional Types Having VWM <= 10V, their ID limit is doubled.

= See General Information for Impulse Current Waveform.

1.5KE Series – 1500 Watt



1.5KE Series Features

- RoHS Compliance Standard
- 1500 watt peak pulse power dissipation
- Available in voltages from 6.8V to 550V
- Unidirectional and Bidirectional
- Glass passivated junction
- Low clamping factor
- Available in bulk or tape and reel (Reel quantity = 1,200 pieces)
- Each device 100% surge tested
- Metal hermetically sealed (DO13) version of this diode is available upon request
- UL 497B Recognized, File # E135015
- Tape and Reel to EIA Standard RS-296-E
- AEC-Q101 Qualified (11A & 11CA – 500A & 550CA) types. (When ordering ADD suffix “Z” to end of part number.)

Absolute Maximum Ratings

Parameter	Value
Peak pulse power dissipation (PPPM) at 25°C	1500W
Steady state power dissipation at lead temperature = 75°C (Lead length 3/8” min.)	5W
Operating and storage temperatures	-55°C to + 175°C

Mechanical Dimensions

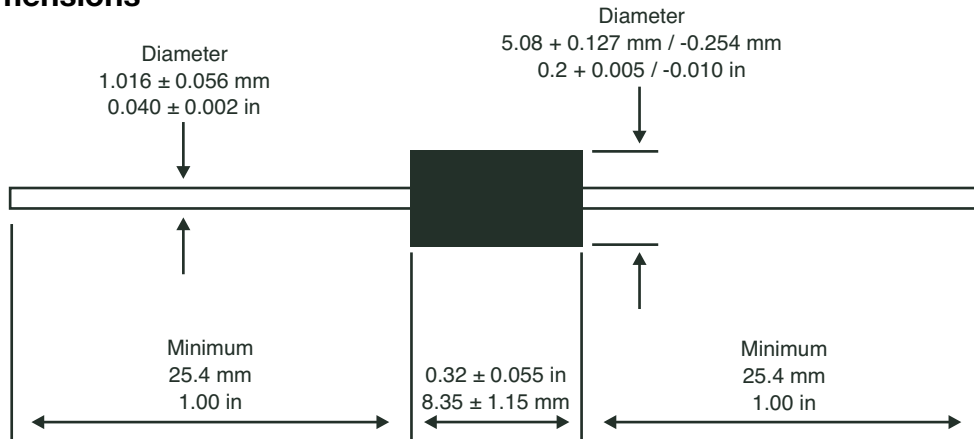

Standard Mounting Pad Layout

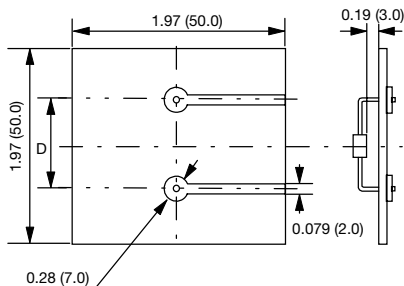

NOTE: Dimension D

- a.) 1.5KE (DO-201 Package) - 0.611 (15.5)
- b.) 3KP / 5KP / 15KP (P600 Package) - 0.673 (17.1)

Hole Diameter

- a.) 0.059 (1.5)

All dimensions in inches and (millimeters)

1.5KE Series – 1500 Watt (continued)**Electrical Characteristics**

Part Number*	Rated Standoff Voltage	Breakdown Voltage			Maximum Stand By Current @VWM+ Id	10/1000 μ s Maximum Clamping Voltage @Ippm# Vc Max	10/1000 μ s Rated Peak Impulse Current Ippm#
		Vbr (Volts)		@It			
	Vwm (Volts)	Min	Max	(mA)	(μ A)	(Volts)	(Amperes)
1.5KE6.8	5.50	6.12	7.48	10	1000	10.8	139.0
1.5KE6.8A	5.80	6.4	7.14	10	1000	10.5	144.8
1.5KE7.5	6.05	6.75	8.25	10	500	11.7	128.0
1.5KE7.5A	6.40	7.13	7.88	10	500	11.3	134.5
1.5KE8.2	6.63	7.38	9.02	10	200	12.5	120.0
1.5KE8.2A	7.02	7.79	8.61	10	200	12.1	125.6
1.5KE9.1	7.37	8.19	10.0	1	50	13.8	109.0
1.5KE9.1A	7.78	8.65	9.55	1	50	13.4	113.4
1.5KE10	8.10	9.00	11.0	1	10	15.0	100.0
1.5KE10A	8.55	9.5	10.5	1	10	14.5	104.8
1.5KE11	8.92	9.9	12.1	1	5	16.2	93.0
1.5KE11A	9.40	10.5	11.6	1	5	15.6	97.4
1.5KE12	9.72	10.8	13.2	1	5	17.3	87.0
1.5KE12A	10.2	11.4	12.6	1	5	16.7	91.0
1.5KE13	10.5	11.7	14.3	1	1	19.0	79.0
1.5KE13A	11.1	12.4	13.7	1	1	18.2	83.5
1.5KE15	12.1	13.5	16.5	1	1	22.0	68.0
1.5KE15A	12.8	14.3	15.8	1	1	21.2	71.7
1.5KE16	12.9	14.4	17.6	1	1	23.5	64.0
1.5KE16A	13.6	15.2	16.8	1	1	22.5	67.6
1.5KE18	14.5	16.2	19.8	1	1	26.5	56.5
1.5KE18A	15.3	17.1	18.9	1	1	25.2	60.3
1.5KE20	16.2	18.0	22.0	1	1	29.1	51.5
1.5KE20A	17.1	19.0	21.0	1	1	27.7	54.9
1.5KE22	17.8	19.8	24.2	1	1	31.9	47.0
1.5KE22A	18.8	20.9	23.1	1	1	30.6	49.7
1.5KE24	19.4	21.6	26.4	1	1	34.7	43.0
1.5KE24A	20.5	22.8	25.2	1	1	33.2	45.8
1.5KE27	21.8	24.3	29.7	1	1	39.1	38.5

Metal hermetically sealed (DO13) version of this diode is available upon request.

* = Add "C" or "CA" suffix for bidirectional device types.

+ = For Bidirectional Types Having VWM \leq 10V, their ID limit is doubled.

= See General Information for Impulse Current Waveform.

1.5KE Series – 1500 Watt (continued)**Electrical Characteristics (continued)**

Part Number*	Rated Standoff Voltage	Breakdown Voltage			Maximum Stand By Current @VWM+ Id	10/1000µs Maximum Clamping Voltage @Ippm# Vc Max	10/1000µs Rated Peak Impulse Current Ippm#
		Vbr (Volts)		@It			
	Vwm (Volts)	Min	Max	(mA)	(µA)	(Volts)	(Amperes)
1.5KE27A	23.1	25.7	28.4	1	1	37.5	40.5
1.5KE30	24.3	27.0	33.0	1	1	43.5	34.5
1.5KE30A	25.6	28.5	31.5	1	1	41.4	36.7
1.5KE33	26.8	29.7	36.3	1	1	47.7	31.5
1.5KE33A	28.2	31.4	34.7	1	1	45.7	33.3
1.5KE36	29.1	32.4	39.6	1	1	52.0	29.0
1.5KE36A	30.8	34.2	37.8	1	1	49.9	30.5
1.5KE39	31.6	35.1	42.9	1	1	56.4	26.5
1.5KE39A	33.3	37.1	41.0	1	1	53.9	28.2
1.5KE43	34.8	38.7	47.3	1	1	61.9	24.0
1.5KE43A	36.8	40.9	45.2	1	1	59.3	25.6
1.5KE47	38.1	42.3	51.7	1	1	67.8	22.2
1.5KE47A	40.2	44.7	49.4	1	1	64.8	23.5
1.5KE51	41.3	45.9	56.1	1	1	73.5	20.4
1.5KE51A	43.6	48.5	53.6	1	1	70.1	21.7
1.5KE56	45.4	50.4	61.6	1	1	80.5	18.6
1.5KE56A	47.8	53.2	58.8	1	1	77.0	19.7
1.5KE62	50.2	55.8	68.2	1	1	89.0	16.9
1.5KE62A	53.0	58.9	65.1	1	1	85.0	17.9
1.5KE68	55.1	61.2	74.8	1	1	98.0	15.3
1.5KE68A	58.1	64.6	71.4	1	1	92.0	16.5
1.5KE75	60.7	67.5	82.5	1	1	108.0	13.9
1.5KE75A	64.1	71.3	78.8	1	1	103.0	14.8
1.5KE82	66.4	73.8	90.2	1	1	118.0	12.7
1.5KE82A	70.1	77.9	86.1	1	1	113.0	13.5
1.5KE91	73.7	81.9	100.0	1	1	131.0	11.4
1.5KE91A	77.8	86.5	95.5	1	1	125.0	12.2
1.5KE100	81.0	90.0	110.0	1	1	144.0	10.4
1.5KE100A	85.5	95.0	105.0	1	1	137.0	11.1

Metal hermetically sealed (DO13) version of this diode is available upon request.

* = Add "C" or "CA" suffix for bidirectional device types.

+ = For Bidirectional Types Having VWM <= 10V, their ID limit is doubled.

= See General Information for Impulse Current Waveform.

1.5KE Series – 1500 Watt (continued)**Electrical Characteristics (continued)**

Part Number*	Rated Standoff Voltage	Breakdown Voltage			Maximum Stand By Current @VWM+ Id	10/1000µs Maximum Clamping Voltage @Ippm# Vc Max	10/1000µs Rated Peak Impulse Current Ippm#
		Vbr (Volts)		@It			
	Vwm (Volts)	Min	Max	(mA)	(µA)	(Volts)	(Amperes)
1.5KE110	89.2	99.0	121.0	1	1	158.0	9.5
1.5KE110A	94.0	105.0	116.0	1	1	152.0	10.0
1.5KE120	97.2	108.0	132.0	1	1	173.0	8.7
1.5KE120A	102.0	114.0	126.0	1	1	165.0	9.2
1.5KE130	105.0	117.0	143.0	1	1	187.0	8.0
1.5KE130A	111.0	124.0	137.0	1	1	179.0	8.5
1.5KE150	121.0	135.0	165.0	1	1	215.0	7.0
1.5KE150A	128.0	143.0	158.0	1	1	207.0	7.3
1.5KE160	130.0	144.0	176.0	1	1	230.0	6.5
1.5KE160A	136.0	152.0	168.0	1	1	219.0	6.9
1.5KE170	138.0	153.0	187.0	1	1	244.0	6.2
1.5KE170A	145.0	162.0	179.0	1	1	234.0	6.5
1.5KE180	146.0	162.0	198.0	1	1	258.0	5.8
1.5KE180A	154.0	171.0	189.0	1	1	246.0	6.2
1.5KE200	162.0	180.0	220.0	1	1	287.0	5.2
1.5KE200A	171.0	190.0	210.0	1	1	274.0	5.5
1.5KE220	175.0	198.0	242.0	1	1	344.0	4.3
1.5KE220A	185.0	209.0	231.0	1	1	328.0	4.6
1.5KE250	202.0	225.0	275.0	1	1	360.0	5.0
1.5KE250A	214.0	237.0	263.0	1	1	344.0	4.4
1.5KE300	243.0	270.0	330.0	1	1	430.0	5.0
1.5KE300A	256.0	285.0	315.0	1	1	414.0	3.7
1.5KE350	284.0	315.0	385.0	1	1	504.0	4.0
1.5KE350A	300.0	332.0	368.0	1	1	482.0	3.2
1.5KE400	324.0	360.0	440.0	1	1	574.0	4.0
1.5KE400A	342.0	380.0	420.0	1	1	548.0	2.8
1.5KE440	356.0	396.0	484.0	1	1	631.0	2.4
1.5KE440A	376.0	418.0	462.0	1	1	600.0	2.5
1.5KE480A	408.0	456.0	504.0	1	1	658.0	2.3
1.5KE510A	434.0	485.0	535.0	1	1	698.0	2.1
1.5KE530A	450.0	503.5	556.5	1	1	725.0	2.1
1.5KE540A	459.0	513.0	567.0	1	1	740.0	2.0
1.5KE550A	467.0	522.5	577.5	1	1	760.0	2.0

Metal hermetically sealed (DO13) version of this diode is available upon request.

* = Add "C" or "CA" suffix for bidirectional device types.

+ = For Bidirectional Types Having VWM <= 10V, their ID limit is doubled.

= See General Information for Impulse Current Waveform.

3KP Series – 3000 Watt



3KP Series Features

- RoHS Compliance Standard
- 3000 watt peak pulse power dissipation
- Available in voltages from 5V to 220V
- Unidirectional and Bidirectional
- Glass passivated junction
- Low clamping factor
- Available in bulk or tape and reel (Reel quantity = 800 pieces)
- Each device 100% surge tested
- UL 497B Recognized, File # E135015
- Tape and Reel to EIA Standard RS-296-E
- AEC-Q101 Qualified (11A & 11CA – 220A & 220CA) types. (When ordering ADD suffix “Z” to end of part number.)

Absolute Maximum Ratings

Parameter	Value
Peak pulse power dissipation (PPPM) at 25°C	3000W
Steady state power dissipation at lead temperature = 75°C (Lead length 3/8” min.)	8W
Operating and storage temperatures	-55°C to + 175°C

Mechanical Dimensions

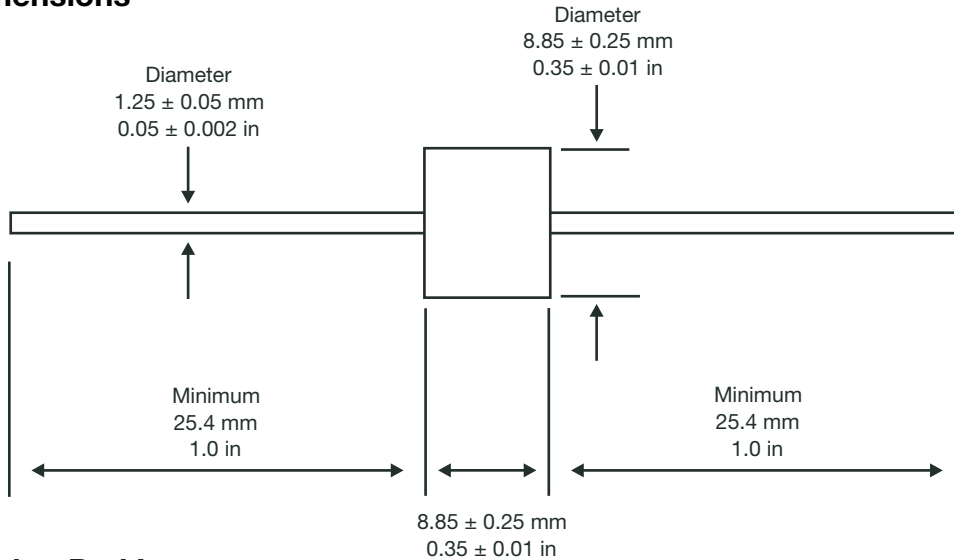

Standard Mounting Pad Layout

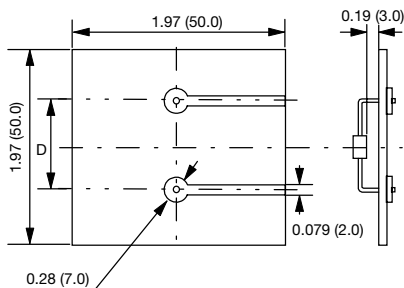

NOTE: Dimension D
 a.) 1.5KE (DO-201 Package) - 0.611 (15.5)
 b.) 3KP / 5KP /15KP (P600 Package) - 0.673 (17.1)
Hole Diameter
 a.) 0.059 (1.5)

All dimensions in inches and (millimeters)

3KP Series – 3000 Watt (continued)**Electrical Characteristics**

Part Number*	Rated Standoff Voltage	Breakdown Voltage			Maximum Stand By Current @VWM+ Id	10/1000µs Maximum Clamping Voltage @Ippm# Vc Max	10/1000µs Rated Peak Impulse Current Ippm#
		Vbr (Volts)		@It			
	Vwm (Volts)	Min	Max	(mA)	(µA)	(Volts)	(Amperes)
3KP5.0A	5.0	6.40	7.00	10	5000	9.2	326.1
3KP6.0A	6.0	6.67	7.37	10	5000	10.3	291.3
3KP6.5A	6.5	7.22	7.98	10	2000	11.2	267.9
3KP7.0A	7.0	7.78	8.60	10	1000	12.0	250.0
3KP7.5A	7.5	8.33	9.21	1	250	12.9	232.6
3KP8.0A	8.0	8.89	9.83	1	150	13.6	220.6
3KP8.5A	8.5	9.44	10.40	1	50	14.4	208.3
3KP9.0A	9.0	10.00	11.10	1	20	15.4	194.8
3KP10	10.00	11.10	14.10	1	15	18.8	159.6
3KP10A	10.00	11.10	12.30	1	15	17.0	176.5
3KP11	11.00	12.20	15.40	1	2	20.1	149.2
3KP11A	11.00	12.20	13.50	1	2	18.2	164.8
3KP12	12.00	13.30	16.90	1	2	22.0	136.4
3KP12A	12.00	13.30	14.70	1	2	19.9	150.8
3KP13	13.00	14.40	18.20	1	2	23.8	126.0
3KP13A	13.00	14.40	15.90	1	2	21.5	139.5
3KP14	14.00	15.60	19.80	1	2	25.8	116.2
3KP14A	14.00	15.60	17.20	1	2	23.2	129.3
3KP15	15.00	16.70	21.10	1	2	26.9	111.6
3KP15A	15.00	16.70	18.50	1	2	24.4	123.0
3KP16	16.00	17.80	22.60	1	2	28.8	104.2
3KP16A	16.00	17.80	19.70	1	2	26.0	115.4
3KP17	17.00	18.90	23.90	1	2	30.5	98.4
3KP17A	17.00	18.90	20.90	1	2	27.6	108.7
3KP18	18.00	20.00	25.30	1	2	32.2	93.2
3KP18A	18.00	20.00	22.10	1	2	29.2	102.7
3KP20	20.00	22.20	28.10	1	2	35.8	83.8
3KP20A	20.00	22.20	24.50	1	2	32.4	92.6
3KP22	22.00	24.40	30.90	1	2	39.4	76.2
3KP22A	22.00	24.40	26.90	1	2	35.5	84.5
3KP24	24.00	26.70	33.80	1	2	43.0	69.8
3KP24A	24.00	26.70	29.50	1	2	38.9	77.1
3KP26	26.00	28.90	36.60	1	2	46.6	64.4
3KP26A	26.00	28.90	31.90	1	2	42.1	71.3

Add "C" or "CA" suffix for bidirectional device types.

+ = For Bidirectional Types Having VWM <= 10V, their ID limit is doubled.

= See General Information for Impulse Current Waveform.

3KP Series – 3000 Watt (continued)**Electrical Characteristics (continued)**

Part Number*	Rated Standoff Voltage	Breakdown Voltage			Maximum Stand By Current @VWM+ Id	10/1000 μ s Maximum Clamping Voltage @Ippm# Vc Max	10/1000 μ s Rated Peak Impulse Current Ippm#
		Vbr (Volts)		@It			
	Vwm (Volts)	Min	Max	(mA)	(μ A)	(Volts)	(Amperes)
3KP28	28.00	31.10	39.40	1	2	50.0	60.0
3KP28A	28.00	31.10	34.40	1	2	45.4	66.1
3KP30	30.00	33.30	42.20	1	2	53.5	56.0
3KP30A	30.00	33.30	36.80	1	2	48.4	62.0
3KP33	33.00	36.70	46.50	1	2	59.0	50.4
3KP33A	33.00	36.70	40.60	1	2	53.3	56.3
3KP36	36.00	40.00	50.70	1	2	64.3	46.6
3KP36A	36.00	40.00	44.20	1	2	58.1	51.6
3KP40	40.00	44.40	53.30	1	2	71.4	42.0
3KP40A	40.00	44.40	49.10	1	2	64.5	46.5
3KP43	43.00	47.80	60.50	1	2	76.7	39.2
3KP43A	43.00	47.80	52.80	1	2	69.4	43.2
3KP45	45.00	50.00	63.30	1	2	80.3	37.4
3KP45A	45.00	50.00	55.30	1	2	72.7	41.3
3KP48	48.00	53.30	67.50	1	2	85.5	35.0
3KP48A	48.00	53.30	58.90	1	2	77.4	38.8
3KP51	51.00	56.70	71.80	1	2	91.1	37.0
3KP51A	51.00	56.70	62.70	1	2	82.4	36.4
3KP54	54.00	60.00	76.00	1	2	96.3	31.2
3KP54A	54.00	60.00	66.30	1	2	87.1	34.4
3KP58	58.00	64.40	81.60	1	2	103.0	29.2
3KP58A	58.00	64.40	71.20	1	2	93.6	32.1
3KP60	60.00	66.70	84.50	1	2	107.0	28.0
3KP60A	60.00	66.70	73.70	1	2	96.8	31.0
3KP64	64.00	71.10	90.10	1	2	114.0	26.4
3KP64A	64.00	71.10	78.60	1	2	103.0	29.1
3KP70	70.00	77.80	98.60	1	2	125.0	24.0
3KP70A	70.00	77.80	86.00	1	2	113.0	26.5
3KP75	75.00	83.30	105.70	1	2	134.0	22.4
3KP75A	75.00	83.30	92.10	1	2	121.0	24.8

Add "C" or "CA" suffix for bidirectional device types.

+ = For Bidirectional Types Having VWM \leq 10V, their ID limit is doubled.

= See General Information for Impulse Current Waveform.

3KP Series – 3000 Watt (continued)**Electrical Characteristics (continued)**

Part Number*	Rated Standoff Voltage	Breakdown Voltage			Maximum Stand By Current @VWM+ Id	10/1000µs Maximum Clamping Voltage @Ippm# Vc Max	10/1000µs Rated Peak Impulse Current Ippm#
		Vbr (Volts)		@It			
	Vwm (Volts)	Min	Max	(mA)	(µA)	(Volts)	(Amperes)
3KP78	78.00	86.70	109.80	1	2	139.0	21.6
3KP78A	78.00	86.70	95.80	1	2	126.0	23.8
3KP85	85.00	94.40	119.20	1	2	151.0	19.8
3KP85A	85.00	94.40	104.00	1	2	137.0	21.9
3KP90	90.00	100.00	126.50	1	2	160.0	18.8
3KP90A	90.00	100.00	111.00	1	2	146.0	20.5
3KP100	100.00	111.00	141.00	1	2	179.0	16.6
3KP100A	100.00	111.00	123.00	1	2	162.0	18.5
3KP110	110.00	122.00	154.50	1	2	196.0	15.4
3KP110A	110.00	122.00	135.00	1	2	177.0	16.9
3KP120	120.00	133.00	169.00	1	2	214.0	14.0
3KP120A	120.00	133.00	147.00	1	2	193.0	15.5
3KP130	130.00	144.00	182.50	1	2	231.0	13.0
3KP130A	130.00	144.00	159.00	1	2	209.0	14.4
3KP150	150.00	167.00	211.50	1	2	268.0	11.2
3KP150A	150.00	167.00	185.00	1	2	243.0	12.3
3KP160	160.00	178.00	226.00	1	2	287.0	10.4
3KP160A	160.00	178.00	197.00	1	2	259.0	11.6
3KP170	170.00	189.00	239.50	1	2	304.0	9.8
3KP170A	170.00	189.00	209.00	1	2	275.0	10.9
3KP180	180.00	198.00	242.00	1	2	322.0	9.3
3KP180A	180.00	201.00	222.00	1	2	292.0	10.3
3KP190	190.00	209.00	255.40	1	2	340.0	8.8
3KP190A	190.00	211.00	233.00	1	2	308.0	9.7
3KP200	200.00	220.00	268.80	1	2	358.0	8.4
3KP200A	200.00	224.00	247.00	1	2	324.0	9.3
3KP210	210.00	231.00	282.20	1	2	376.0	8.0
3KP210A	210.00	237.00	263.00	1	2	340.0	8.8
3KP220	220.00	242.00	295.70	1	2	394.0	7.6
3KP220A	220.00	246.00	272.00	1	2	356.0	8.4

Add "C" or "CA" suffix for bidirectional device types.

+ = For Bidirectional Types Having VWM <= 10V, their ID limit is doubled.

= See General Information for Impulse Current Waveform.

5KP Series –5000 Watt



5KP Series Features

- RoHS Compliance Standard
- 5000 watt peak pulse power dissipation
- Available in voltages from 5V to 250V
- Unidirectional and Bidirectional
- Glass passivated junction
- Low clamping factor
- Available in bulk or tape and reel (Reel quantity = 800 pieces)
- Each device 100% surge tested
- UL 497B Recognized, File # E135015
- Tape and Reel to EIA Standard RS-296-E
- AEC-Q101 Qualified (11A & 11CA – 250A & 250CA) types. (When ordering ADD suffix “Z” to end of part number.)

Absolute Maximum Ratings

Parameter	Value
Peak pulse power dissipation (PPPM) at 25°C	5000W
Steady state power dissipation at lead temperature = 75°C (Lead length 3/8” min.)	8W
Operating and storage temperatures	-55°C to + 175°C

Mechanical Dimensions

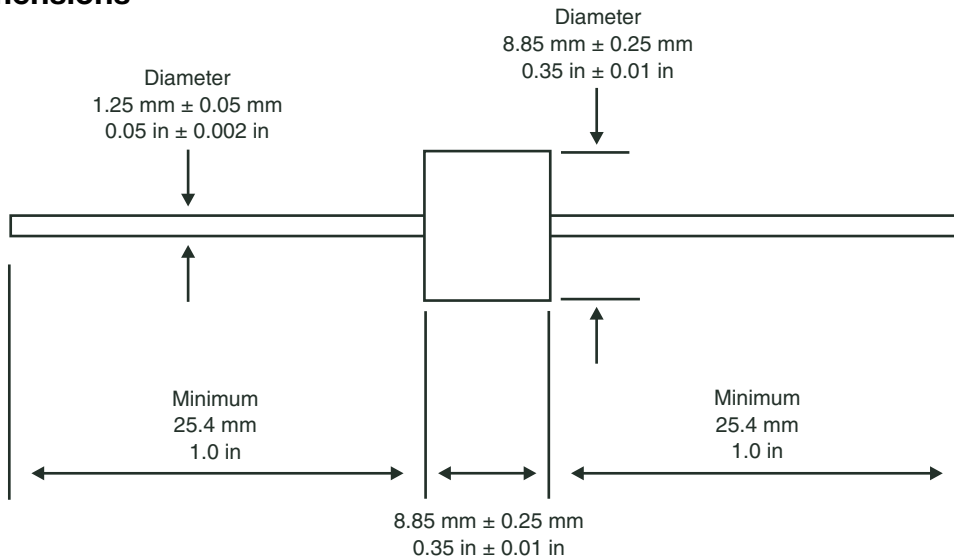

Standard Mounting Pad Layout

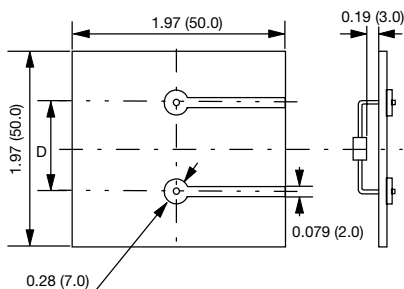

NOTE: Dimension D

- a.) 1.5KE (DO-201 Package) - 0.611 (15.5)
- b.) 3KP / 5KP /15KP (P600 Package) - 0.673 (17.1)

Hole Diameter

- a.) 0.059 (1.5)

All dimensions in inches and (millimeters)

5KP Series – 5000 Watt (continued)**Electrical Characteristics**

Part Number*	Rated Standoff Voltage	Breakdown Voltage			Maximum Stand By Current @VWM+ Id	10/1000µs Maximum Clamping Voltage @Ippm# Vc Max	10/1000µs Rated Peak Impulse Current Ippm#
		Vbr (Volts)		@It			
	Vwm (Volts)	Min	Max	(mA)	(µA)	(Volts)	(Amperes)
5KP5.0	5.0	6.40	7.30	50	5000	9.6	520.0
5KP5.0A	5.0	6.40	7.00	50	5000	9.2	554.3
5KP6.0	6.0	6.67	8.15	50	5000	11.4	439.0
5KP6.0A	6.0	6.67	7.37	50	5000	10.3	495.1
5KP6.5	6.5	7.22	8.82	50	2000	12.3	407.0
5KP6.5A	6.5	7.22	7.98	50	2000	11.2	455.4
5KP7.0	7.0	7.78	9.51	50	1000	13.3	378.0
5KP7.0A	7.0	7.78	8.60	50	1000	12.0	425.0
5KP7.5	7.5	8.33	10.20	5.0	250	14.3	350.0
5KP7.5A	7.5	8.33	9.21	5.0	250	12.9	395.3
5KP8.0	8.0	8.89	10.90	5.0	150	15.0	333.0
5KP8.0A	8.0	8.89	9.83	5.0	150	13.6	375.0
5KP8.5	8.5	9.44	11.50	5.0	50	15.9	314.0
5KP8.5A	8.5	9.44	10.40	5.0	50	14.4	354.2
5KP9.0	9.0	10.00	12.20	5.0	20	16.9	295.0
5KP9.0A	9.0	10.00	11.10	5.0	20	15.4	331.2
5KP10	10.0	11.1	13.6	5.0	15	18.8	266.0
5KP10A	10.0	11.1	12.3	5.0	15	17.0	300.0
5KP11	11.0	12.2	14.9	5.0	2	20.1	249.0
5KP11A	11.0	12.2	13.5	5.0	2	18.2	280.2
5KP12	12.0	13.3	16.3	5.0	2	22.0	227.0
5KP12A	12.0	13.3	14.7	5.0	2	19.9	256.3
5KP13	13.0	14.4	17.6	5.0	2	23.8	210.0
5KP13A	13.0	14.4	15.9	5.0	2	21.5	237.2
5KP14	14.0	15.6	19.1	5.0	2	25.8	194.0
5KP14A	14.0	15.6	17.2	5.0	2	23.2	219.8
5KP15	15.0	16.7	20.4	5.0	2	26.9	188.0
5KP15A	15.0	16.7	18.5	5.0	2	24.4	209.0
5KP16	16.0	17.8	21.8	5.0	2	28.8	176.0
5KP16A	16.0	17.8	19.7	5.0	2	26.0	196.2

* = Add "C" or "CA" suffix for bidirectional device types.

+ = For Bidirectional Types Having VWM <= 10V, their ID limit is doubled.

= See General Information for Impulse Current Waveform

5KP Series – 5000 Watt (continued)**Electrical Characteristics (continued)**

Part Number*	Rated Standoff Voltage	Breakdown Voltage			Maximum Stand By Current @VWM+ Id	10/1000µs Maximum Clamping Voltage @Ippm# Vc Max	10/1000µs Rated Peak Impulse Current Ippm#
		Vbr (Volts)		@It			
	Vwm (Volts)	Min	Max	(mA)	(µA)	(Volts)	(Amperes)
5KP17	17.0	18.9	23.1	5.0	2	30.5	164.0
5KP17A	17.0	18.9	20.9	5.0	2	27.6	184.8
5KP18	18.0	20.0	24.4	5.0	2	32.2	155.0
5KP18A	18.0	20.0	22.1	5.0	2	29.2	174.7
5KP20	20.0	22.2	27.1	5.0	2	35.8	139.0
5KP20A	20.0	22.2	24.5	5.0	2	32.4	157.4
5KP22	22.0	24.4	29.8	5.0	2	39.4	127.0
5KP22A	22.0	24.4	26.9	5.0	2	35.5	143.7
5KP24	24.0	26.7	32.6	5.0	2	43.0	116.0
5KP24A	24.0	26.7	29.5	5.0	2	38.9	131.1
5KP26	26.0	28.9	35.3	5.0	2	46.6	107.0
5KP26A	26.0	28.9	31.9	5.0	2	42.1	121.1
5KP28	28.0	31.1	39.0	5.0	2	50.1	99.0
5KP28A	28.0	31.1	34.4	5.0	2	45.4	112.3
5KP30	30.0	33.3	40.7	5.0	2	53.5	93.0
5KP30A	30.0	33.3	36.8	5.0	2	48.4	105.4
5KP33	33.0	36.7	44.9	5.0	2	59.0	85.0
5KP33A	33.0	36.7	40.6	5.0	2	53.3	95.7
5KP36	36.0	40.0	48.9	5.0	2	64.3	78.0
5KP36A	36.0	40.0	44.2	5.0	2	58.1	87.8
5KP40	40.0	44.4	54.3	5.0	2	71.4	70.0
5KP40A	40.0	44.4	49.1	5.0	2	64.5	79.1
5KP43	43.0	47.8	58.4	5.0	2	76.7	65.0
5KP43A	43.0	47.8	52.8	5.0	2	69.4	73.5
5KP45	45.0	50.0	61.1	5.0	2	80.3	62.0
5KP45A	45.0	50.0	55.3	5.0	2	72.7	70.2
5KP48	48.0	53.3	65.2	5.0	2	85.5	58.0
5KP48A	48.0	53.3	58.9	5.0	2	77.4	65.9
5KP51	51.0	56.7	69.3	5.0	2	91.1	55.0
5KP51A	51.0	56.7	62.7	5.0	2	82.4	61.9

* = Add "C" or "CA" suffix for bidirectional device types.

+ = For Bidirectional Types Having VWM <= 10V, their ID limit is doubled.

= See General Information for Impulse Current Waveform

5KP Series – 5000 Watt (continued)**Electrical Characteristics (continued)**

Part Number*	Rated Standoff Voltage	Breakdown Voltage			Maximum Stand By Current @VWM+ Id	10/1000µs Maximum Clamping Voltage @Ippm# Vc Max	10/1000µs Rated Peak Impulse Current Ippm#
		Vbr (Volts)		@It			
	Vwm (Volts)	Min	Max	(mA)	(µA)	(Volts)	(Amperes)
5KP54	54.0	60.0	73.3	5.0	2	96.3	52.0
5KP54A	54.0	60.0	66.3	5.0	2	87.1	58.6
5KP58	58.0	64.4	78.7	5.0	2	103.0	49.0
5KP58A	58.0	64.4	71.2	5.0	2	93.6	54.5
5KP60	60.0	66.7	81.5	5.0	2	107.0	47.0
5KP60A	60.0	66.7	73.7	5.0	2	96.8	52.7
5KP64	64.0	71.1	96.9	5.0	2	114.0	44.0
5KP64A	64.0	71.1	78.6	5.0	2	103.0	49.5
5KP70	70.0	77.8	95.1	5.0	2	125.0	40.0
5KP70A	70.0	77.8	86.0	5.0	2	113.0	45.1
5KP75	75.0	83.3	102.0	5.0	2	134.0	37.0
5KP75A	75.0	83.3	92.1	5.0	2	121.0	42.1
5KP78	78.0	86.7	106.0	5.0	2	139.0	36.0
5KP78A	78.0	86.7	95.8	5.0	2	126.0	40.5
5KP85	85.0	94.4	115.0	5.0	2	151.0	33.0
5KP85A	85.0	94.4	104.0	5.0	2	137.0	37.2
5KP90	90.0	100.0	122.0	5.0	2	160.0	31.0
5KP90A	90.0	100.0	111.0	5.0	2	146.0	34.9
5KP100	100.0	111.0	136.0	5.0	2	179.0	28.0
5KP100A	100.0	110.0	123.0	5.0	2	162.0	31.5
5KP110	110.0	122.0	149.0	5.0	2	196.0	26.0
5KP110A	110.0	122.0	135.0	5.0	2	177.0	28.8
5KP120	120.0	133.0	163.0	5.0	2	215.0	23.0
5KP120A	120.0	133.0	147.0	5.0	2	193.0	26.4
5KP130A	130.0	144.0	159.0	5.0	2	209.0	24.4
5KP150A	150.0	167.0	185.0	5.0	2	243.0	21.0
5KP160A	160.0	178.0	197.0	5.0	2	259.0	19.7
5KP170A	170.0	189.0	209.0	5.0	2	275.0	18.5
5KP180A	180.0	201.0	222.0	5.0	2	292.0	17.5
5KP190A	190.0	211.0	233.0	5.0	2	310.0	16.5
5KP200A	200.0	224.0	247.0	5.0	2	329.2	15.5
5KP210A	210.0	237.0	263.0	5.0	2	349.5	14.6
5KP220A	220.0	246.0	272.0	5.0	2	371.1	13.7
5KP250A	250.0	277.0	306.0	5.0	2	425.0	12.0

* = Add "C" or "CA" suffix for bidirectional device types.

+ = For Bidirectional Types Having VWM <= 10V, their ID limit is doubled.

= See General Information for Impulse Current Waveform

15KP Series –15000 Watt



15KP Series Features

- RoHS Compliance Standard
- 15000 watt peak pulse power dissipation
- Available in voltages from 17V to 280V
- Unidirectional and Bidirectional
- Glass passivated junction
- Low clamping factor
- Each device 100% surge tested
- Available in bulk or tape and reel (Reel quantity = 300 or 800 pieces)
- UL 497B Recognized, File # E135015
- Tape and Reel to EIA Standard RS-296-E

Absolute Maximum Ratings

Parameter	Value
Peak pulse power dissipation (PPPM) at 25°C	15000W
Steady state power dissipation at lead temperature = 75°C (Lead length 3/8" min.)	8W
Operating and storage temperatures	-55°C to +175°C

Mechanical Dimensions

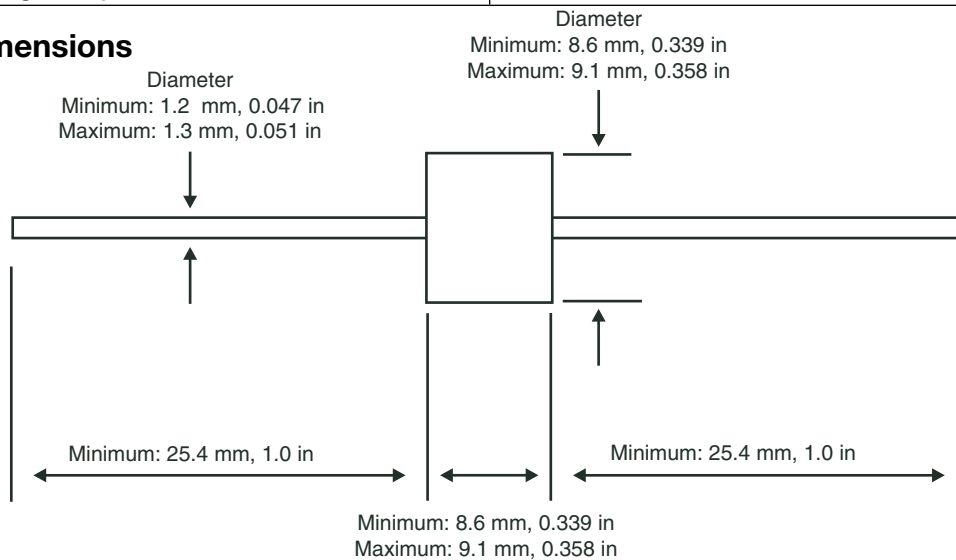

Standard Mounting Pad Layout

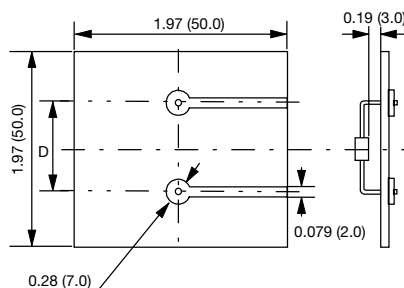

NOTE: Dimension D

- a.) 1.5KE (DO-201 Package) - 0.611 (15.5)
- b.) 3KP / 5KP / 15KP (P600 Package) - 0.673 (17.1)

Hole Diameter

- a.) 0.059 (1.5)

All dimensions in inches and (millimeters)

15KP Series – 15000 Watt (continued)**Electrical Characteristics**

Part Number*	Rated Standoff Voltage V _{wm}	Breakdown Voltage		Maximum Stand By Current @V _{WM} + I _d	10/1000µs Maximum Clamping Voltage @I _{ppm} # V _c Max	10/1000µs Rated Peak Impulse Current I _{ppm} #
		V _{br} (Volts)	@I _t			
	V _{wm} (Volts)	Min	(mA)	(µA)	(Volts)	(Amperes)
15KP17A	17	18.99	50	5000	29.3	515.4
15KP18A	18	20.11	50	5000	30.9	488.7
15KP20A	20	22.34	20	1500	34.3	440.2
15KP22A	22	24.57	10	500	37.1	407.0
15KP24A	24	26.81	5	150	40.7	371.0
15KP26A	26	29.04	5	50	44.0	343.2
15KP28A	28	31.28	5	25	47.5	317.9
15KP30	30	33.3	5	15	56.2	267.0
15KP30A	30	33.51	5	15	50.7	297.8
15KP33	33	36.7	5	2	60.6	248.0
15KP33A	33	36.9	5	2	54.8	276.1
15KP36	36	40.0	5	2	66.0	227.0
15KP36A	36	40.2	5	2	59.8	252.5
15KP40	40	44.4	5	2	72.8	206.0
15KP40A	40	44.7	5	2	65.8	229.5
15KP43	43	47.8	5	2	77.1	195.0
15KP43A	43	48	5	2	69.8	216.3
15KP45	45	50.0	5	2	80.7	186.0
15KP45A	45	50.3	5	2	72.8	207.4
15KP48	48	53.3	5	2	85.9	175.0
15KP48A	48	53.6	5	2	77.7	194.3
15KP51	51	56.7	5	2	91.5	164.0
15KP51A	51	57.0	5	2	82.9	182.1
15KP54	54	60.0	5	2	96.8	155.0
15KP54A	54	60.3	5	2	87.7	172.2
15KP58	58	64.4	5	2	104.0	144.0
15KP58A	58	64.8	5	2	93.8	161.0
15KP60	60	66.7	5	2	107.0	140.0
15KP60A	60	67	5	2	97.4	155.0
15KP64	64	71.1	5	2	115.0	130.0
15KP64A	64	71.5	5	2	104.2	144.9
15KP70	70	77.8	5	2	126.0	119.0
15KP70A	70	78.2	5	2	113.6	132.9
15KP75	75	83.3	5	2	135.0	111.0
15KP75A	75	83.8	5	2	122.0	123.8
15KP78	78	86.7	5	2	140.0	107.0
15KP78A	78	87.1	5	2	126.1	119.7

* = Add "C" or "CA" suffix for bidirectional device types.

= See General Information for Impulse Current Waveform

15KP Series – 15000 Watt (continued)**Electrical Characteristics (continued)**

Part Number*	Rated Standoff Voltage V _{wm}	Breakdown Voltage		Maximum Stand By Current @V _{wm} + I _d	10/1000µs Maximum Clamping Voltage @I _{ppm} # V _c Max	10/1000µs Rated Peak Impulse Current I _{ppm} #
		V _{br} (Volts)	@I _t			
	V _{wm} (Volts)	Min	(mA)	(µA)	(Volts)	(Amperes)
15KP85	85	94.4	5	2	152.0	99.0
15KP85A	85	94.9	5	2	137.6	109.7
15KP90	90	100.0	5	2	160.0	94.0
15KP90A	90	100.5	5	2	145.6	103.7
15KP100	100	111.0	5	2	179.0	84.0
15KP100A	100	111.7	5	2	161.3	93.6
15KP110	110	122.0	5	2	196.0	77.0
15KP110A	110	122.9	5	2	178.6	84.5
15KP120	120	133.0	5	2	214.0	70.0
15KP120A	120	134.0	5	2	192.3	78.5
15KP130	130	144.0	5	2	231.0	65.0
15KP130A	130	145.2	5	2	208.3	72.5
15KP150	150	167.0	5	2	268.0	56.0
15KP150A	150	167.6	5	2	241.9	62.4
15KP160	160	178.0	5	2	287.0	52.0
15KP160A	160	178.7	5	2	258.6	58.4
15KP170	170	189.0	5	2	304.0	49.0
15KP170A	170	189.9	5	2	272.7	55.4
15KP180	180	200.0	5	2	321.0	47.0
15KP180A	180	201.1	5	2	288.5	52.3
15KP200	200	222.0	5	2	356.0	42.0
15KP200A	200	223.4	5	2	319.1	47.3
15KP220A	220	245.7	5	2	352.5	42.8
15KP240A	240	268.1	5	2	384.5	39.3
15KP260A	260	290.4	5	2	416.7	36.2
15KP280A	280	312.8	5	2	454.5	33.2

* = Add "C" or "CA" suffix for bidirectional device types.

= See General Information for Impulse Current Waveform



20KP Series – 20000 Watt



20KP Series Features

- RoHS Compliance Standard
- 20000 watt peak pulse power dissipation
- Available in voltages from 20V to 300V
- Unidirectional and Bidirectional
- Glass passivated junction
- Low clamping factor
- Each device 100% surge tested
- Available in bulk or tape and reel (Reel quantity = 800 pieces)
- UL 497B Recognized, File # E135015
- Tape and Reel to EIA Standard RS-296-E

Absolute Maximum Ratings

Parameter	Value
Peak pulse power dissipation (PPPM) at 25°C	20000W
Steady state power dissipation at lead temperature = 75°C (Lead length 3/8" min.)	8W
Operating and storage temperatures	-55°C to +175°C

Mechanical Dimensions

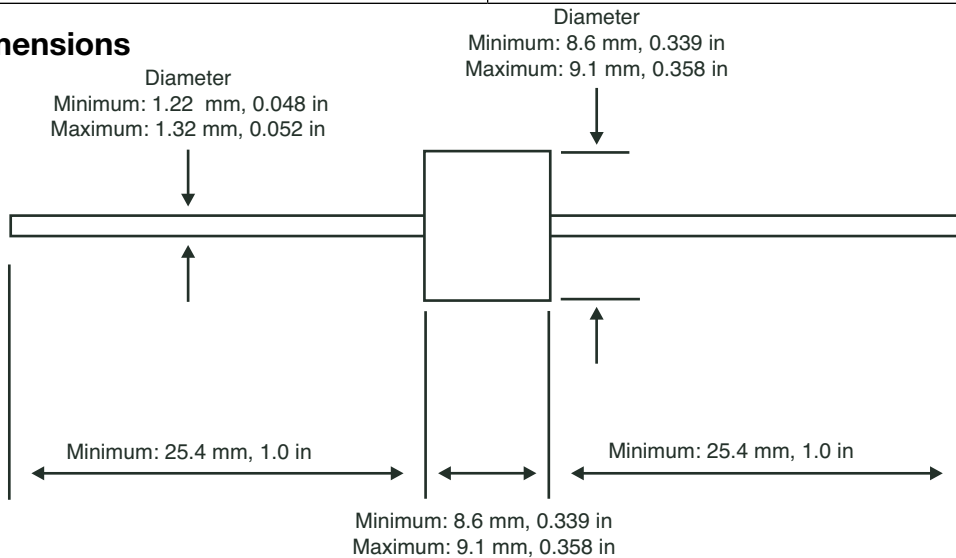

Standard Mounting Pad Layout

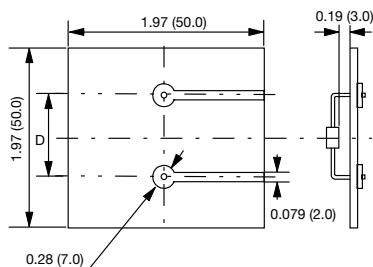

NOTE: Dimension D
a.) 1.5KE (DO-201 Package) - 0.611 (15.5)
b.) 3KP / 5KP / 15KP / 20KP / 30KP (P600 Package) - 0.673 (17.1)

Hole Diameter
a.) 0.059 (1.5)

All dimensions in inches and (millimeters)

20KP Series – 20000 Watt**Electrical Characteristics**

Part Number*	Rated Standoff Voltage V _{wm}	Breakdown Voltage		Maximum Stand By Current @V _{WM} + I _d	10/1000 μ s Maximum Clamping Voltage @I _{ppm} # V _c Max	10/1000 μ s Rated Peak Impulse Current I _{ppm} #
		V _{br} (Volts)	@I _t			
	V _{wm} (Volts)	Min	(mA)	(μ A)	(Volts)	(Amperes)
20KP20A	20	22.34	50	5000	36.8	548.9
20KP24A	24	26.81	50	5000	41.2	490.3
20KP26A	26	29.04	50	2000	44.7	451.9
20KP28A	28	31.28	50	1000	48.0	420.8
20KP30A	30	33.51	5	250	51.5	392.2
20KP32A	32	35.74	5	50	54.3	372.0
20KP34A	34	38.00	5	20	57.5	351.3
20KP36A	36	40.20	5	15	61.5	328.5
20KP40A	40	44.70	5	2	67.8	297.9
20KP44A	44	49.10	5	2	72.7	277.9
20KP48A	48	53.60	5	2	79.4	254.4
20KP52A	52	58.10	5	2	85.8	235.4
20KP56A	56	62.60	5	2	92.6	218.1
20KP60A	60	67.00	5	2	97.6	207.0
20KP64A	64	71.50	5	2	104.0	194.2
20KP68A	68	76.00	5	2	110.0	183.6
20KP72A	72	80.40	5	2	116.0	174.1
20KP80A	80	89.40	5	2	130.0	155.4
20KP88A	88	98.30	5	2	142.0	142.3
20KP96A	96	107.20	5	2	155.0	130.3
20KP104A	104	116.20	5	2	168.0	120.2
20KP112A	112	125.10	5	2	182.0	111.0
20KP120A	120	134.00	5	2	194.0	104.1
20KP132A	132	147.40	5	2	213.0	94.8
20KP144A	144	160.80	5	2	232.0	87.1
20KP160A	160	178.70	5	2	258.0	78.3
20KP172A	172	192.10	5	2	277.0	72.9
20KP180A	180	201.10	5	2	291.0	69.4
20KP192A	192	214.50	5	2	309.0	65.4
20KP204A	204	227.90	5	2	329.0	61.4
20KP216A	216	241.30	5	2	348.0	58.0
20KP232A	232	86.70	5	2	374.0	54.0
20KP240A	240	268.10	5	2	387.0	52.2
20KP256A	256	286.00	5	2	412.0	49.0
20KP280A	280	312.80	5	2	451.0	44.8
20KP300A	300	335.10	5	2	483.0	41.8

* = Add "CA" suffix for bidirectional device types.

= See General Information for Impulse Current Waveform

30KP Series – 30000 Watt



30KP Series Features

- RoHS Compliance Standard
- 30000 watt peak pulse power dissipation
- Available in voltages from 28V to 288V
- Unidirectional and Bidirectional
- Glass passivated junction
- Low clamping factor
- Each device 100% surge tested
- Available in bulk or tape and reel (Reel quantity = 800 pieces)
- UL 497B Recognized, File # E135015
- Tape and Reel to EIA Standard RS-296-E

Absolute Maximum Ratings

Parameter	Value
Peak pulse power dissipation (PPPM) at 25°C	30000W
Steady state power dissipation at lead temperature = 75°C (Lead length 3/8" min.)	8W
Operating and storage temperatures	-55°C to +175°C

Mechanical Dimensions

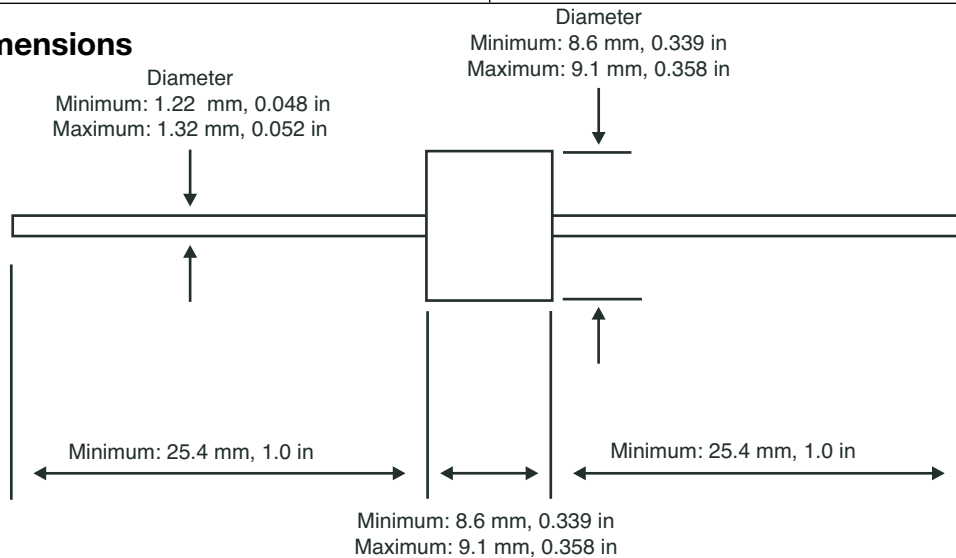

Standard Mounting Pad Layout

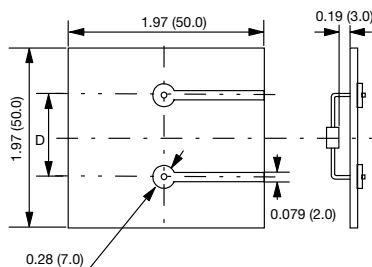

NOTE: Dimension D
 a.) 1.5KE (DO-201 Package) - 0.611 (15.5)
 b.) 3KP / 5KP / 15KP / 20KP / 30KP (P600 Package) - 0.673 (17.1)

Hole Diameter
 a.) 0.059 (1.5)

All dimensions in inches and (millimeters)

30KP Series – 30000 Watt

Electrical Characteristics

Part Number*	Rated Standoff Voltage V _{wm}	Breakdown Voltage		Maximum Stand By Current @V _{WM} + I _d	10/1000µs Maximum Clamping Voltage @I _{ppm} # V _c Max	10/1000µs Rated Peak Impulse Current I _{ppm} #
		V _{br} (Volts)	@I _t			
	V _{wm} (Volts)	Min	(mA)	(µA)	(Volts)	(Amperes)
30KP28A	28	31.28	50	5000	50.0	606.0
30KP30A	30	33.51	50	5000	55.2	548.9
30KP33A	33	36.90	50	5000	58.5	517.9
30KP36A	36	40.20	50	5000	61.8	490.3
30KP39A	39	43.60	20	2000	67.2	450.9
30KP42A	42	46.90	10	1000	72.0	420.8
30KP43A	43	48.00	10	1000	73.0	415.1
30KP45A	45	50.30	5	250	77.4	391.5
30KP48A	48	53.60	5	150	81.6	371.3
30KP51A	51	57.00	5	50	86.4	350.7
30KP54A	54	60.30	5	20	91.4	331.5
30KP58A	58	64.80	5	20	92.4	327.9
30KP60A	60	67.00	5	15	102.0	297.1
30KP64A	64	71.50	5	10	104.0	291.3
30KP66A	66	73.70	5	2	107.0	283.2
30KP70A	70	78.20	5	2	109.0	278.0
30KP71A	71	79.30	5	2	111.5	271.7
30KP72A	72	80.40	5	2	114.0	265.8
30KP75A	75	83.80	5	2	119.4	253.8
30KP78A	78	87.10	5	2	129.0	234.9
30KP84A	84	93.80	5	2	139.2	217.7
30KP90A	90	100.50	5	2	146.4	207.0
30KP96A	96	107.20	5	2	156.0	194.2
30KP102A	102	113.90	5	2	165.6	183.0
30KP108A	108	120.60	5	2	175.2	172.9
30KP120A	120	134.00	5	2	194.4	155.9
30KP132A	132	147.40	5	2	213.0	142.3
30KP144A	144	160.80	5	2	223.2	135.8
30KP150A	150	167.60	5	2	233.4	129.8
30KP158A	158	174.30	5	2	245.0	123.7
30KP160A	160	178.70	5	2	252.6	120.0
30KP168A	168	187.70	5	2	272.4	111.2
30KP170A	170	189.90	5	2	275.0	110.2
30KP180A	180	201.10	5	2	290.4	104.3
30KP198A	198	221.20	5	2	319.8	94.7
30KP216A	216	241.30	5	2	348.6	86.9
30KP240A	240	268.10	5	2	387.0	78.3
30KP258A	258	288.20	5	2	416.4	72.8
30KP260A	260	290.40	5	2	416.0	72.8
30KP270A	270	301.60	5	2	436.2	69.5
30KP280A	280	312.80	5	2	464.0	65.3
30KP288A	288	321.70	5	2	469.9	64.5

* = Add "CA" suffix for bidirectional device types.

= See General Information for Impulse Current Waveform

WLCE Series – Low Capacitance



WLCE Series Features

- RoHS Compliant
- 1500 WATT Peak Pulse Power capability at 10/1000 μ s waveform
- Available in voltages 6.5V to 28V
- Glass Passivated junction
- Low incremented surge resistance
- Fast response time: typically less than 5 μ s from 0 volts to VBR min
- Ideal for dataline applications
- JEDEC DO-201 Plastic molded case
- UL 497B Recognized, File #E135015
- Operating junction and storage temperature (-55°C to + 175°C)
- Tape and Reel to EIA Standard RS - 296 - E

Package Dimensions

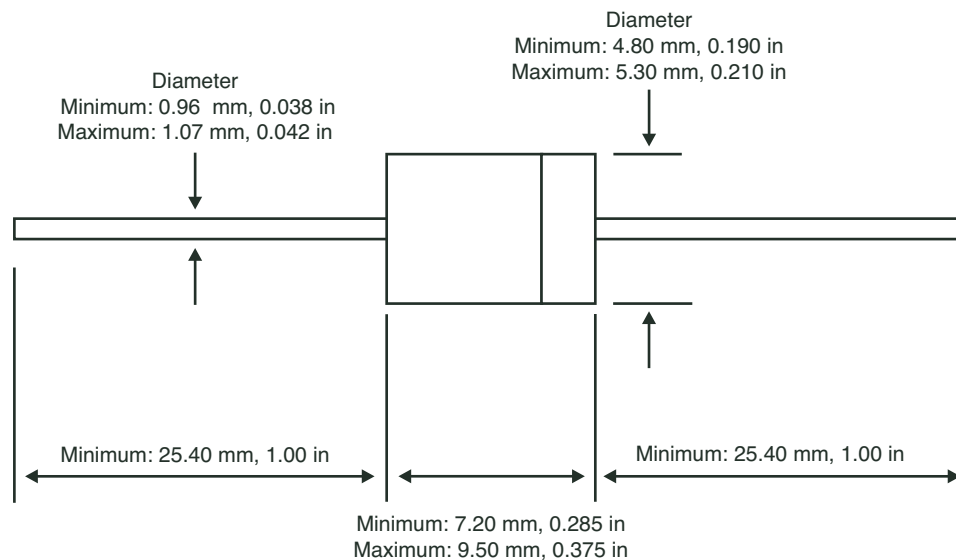

WLCE Series – Low Capacitance

Electrical Characteristics

Part Number	Reverse Stand-Off Voltage V_{RWM}	Breakdown Voltage		Test Current I_T (mA)	Maximum Reverse Leakage @ V_{RWM} I_R (μ A)	Maximum Peak Pulse Current I_{PP} (A)	Maximum Clamping Voltage @ I_{PP} V_C (C)	Maximum Junction Capacitance @ 0V (pF)	Working Inverse Blocking Voltage V_{WIB} (V)	Working Blocking Leaking Current I_{IB} (mA)	Peak Inverse Blocking Voltage V_{PIB} (V)
		V_{BR} (V)	V_{BR} (V)								
	V_{RWM} (V)	Min. @ I_T	Max. @ I_T								
WLCE6.5A	6.5	7.22	7.98	10	1000	100	11.2	100	75	1.0	100
WLCE7.0A	7.0	7.78	8.60	10	500	100	12.0	100	75	1.0	100
WLCE7.5A	7.5	8.33	9.21	10	250	100	12.9	100	75	1.0	100
WLCE8.0A	8.0	8.89	9.83	1	100	100	13.6	100	75	1.0	100
WLCE8.5A	8.5	9.44	10.40	1	50	100	14.4	100	75	1.0	100
WLCE9.0A	9.0	10.00	11.10	1	10	97	15.4	100	75	1.0	100
WLCE10A	10.0	11.10	12.30	1	5	88	17.0	100	75	1.0	100
WLCE11A	11.0	12.20	13.50	1	5	82	18.2	100	75	1.0	100
WLCE12A	12.0	13.30	14.70	1	5	75	19.9	100	75	1.0	100
WLCE13A	13.0	14.40	15.90	1	5	70	21.5	100	75	1.0	100
WLCE14A	14.0	15.60	17.20	1	5	65	23.2	100	75	1.0	100
WLCE15A	15.0	16.70	18.50	1	5	61	24.4	100	75	1.0	100
WLCE16A	16.0	17.60	19.70	1	5	57	26.0	100	75	1.0	100
WLCE17A	17.0	18.90	20.90	1	5	54	27.6	100	75	1.0	100
WLCE18A	18.0	20.00	22.10	1	5	51	29.2	100	75	1.0	100
WLCE20A	20.0	22.20	24.50	1	5	46	32.4	100	75	1.0	100
WLCE22A	22.0	24.40	26.90	1	5	42	35.5	100	75	1.0	100
WLCE24A	24.0	26.70	29.50	1	5	39	38.9	100	75	1.0	100
WLCE26A	26.0	28.90	31.90	1	5	36	42.1	100	75	1.0	100
WLCE28A	28.0	31.10	34.40	1	5	33	45.5	100	75	1.0	100

WFC Series

WFC Series Features

- High current transient suppressor
- Excellent Clamping Capability
- Glass Passivated Junction
- Bi-directional
- RoHS Compliant
- High Temperature soldering: 260°C/10 seconds at terminals
- UL1449 3rd Edition Recognized, File #E321567 (see specific values)

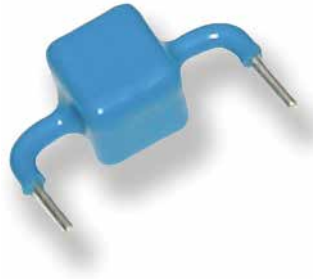

Absolute Maximum Ratings

RATING	SYMBOL	VALUE	UNITS
Current Rating	IPP	0.5, 1.5, 3, 6, 10, 16, 20	KAmps
Operating Junction and Storage Temperature Range	TJ,TSTG	-55 to +125	°C

Package Dimensions

General Lead Series

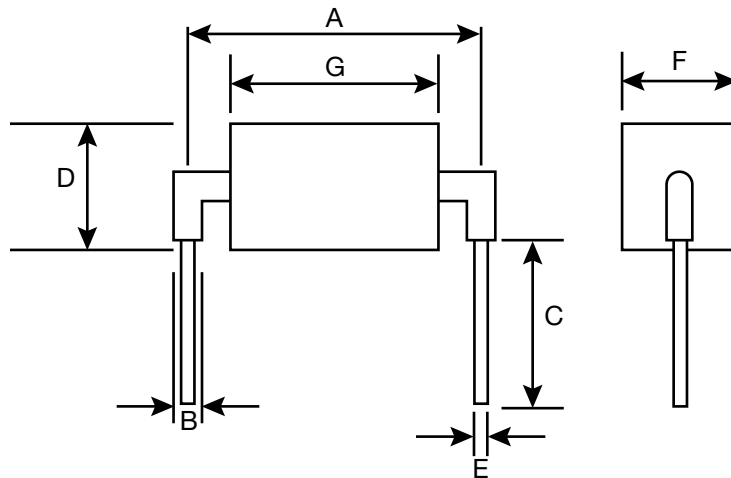

WFC0.5, WFC1, WFC1.5, WFCA, WFCB, WFCC SERIES DIMENSIONS		
DIMENSIONS	INCHES	MILLIMETERS
A	1.00 max.	25.4 max.
B	0.095	2.4
C	0.157	6
D	0.5 max.	13 max.
E	0.05	1.28
F	0.5 max.	13 max.
G	0.8 max.	20.3 max.
TOLERANCE FOR DIMENSIONS: ± 20%		

WFCC (Vr ≥200)/WFCD, WFCE SERIES DIMENSIONS		
DIMENSIONS	INCHES	MILLIMETERS
A	1.00 max.	25.4 max.
B	0.095	2.4
C	0.157	6
D	0.58 max.	14.8 max.
E	0.05	1.28
F	0.58 max.	14.8 max.
G	0.8 max.	20.3 max.
TOLERANCE FOR DIMENSIONS: ± 20%		

WFC Series

Package Dimensions (continued)

Cell Series

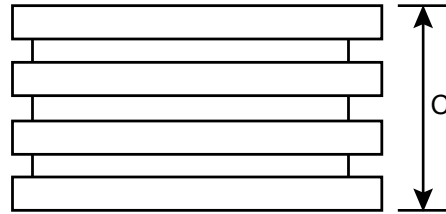
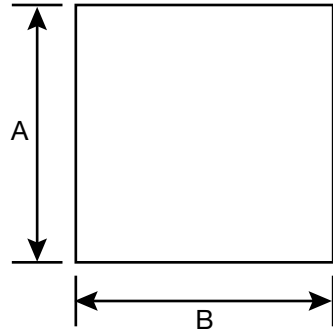

WFC0.5, WFC1, WFC1.5, WFC A, WFC B, WFC C SERIES DIMENSIONS		
DIMENSIONS	INCHES	MILLIMETERS
A	0.374 ± 0.004	9.5 ± 0.1
B	0.374 ± 0.004	9.5 ± 0.1
C	See chart on next page.	

WFCC (V _r ≥ 200)/WFCD, WFCE SERIES DIMENSIONS		
DIMENSIONS	INCHES	MILLIMETERS
A	0.59 ± 0.004	15 ± 0.1
B	0.59 ± 0.004	15 ± 0.1
C	See chart on next page.	

Stack Series

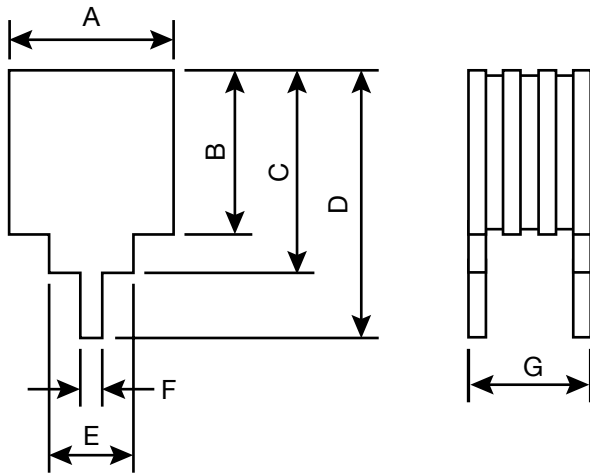

DIMENSIONS	INCHES	MILLIMETERS
A	0.374 ± 0.002	9.5 ± 0.5
B	0.374 ± 0.002	9.5 ± 0.5
C	0.457 ± 0.002	11.6 ± 0.5
D	0.606 ± 0.002	15.4 ± 0.5
E	0.19 ± 0.002	4.83 ± 0.5
F	0.049 ± 0.002	1.25 ± 0.25
G	See chart on next page.	

THIS CHART IS CONTINUED ON THE NEXT PAGE.

WFC Series

Package Dimensions (continued)

Cell and Stack Series

Series Type	Voltage (VDC)	Inches	mm
WFC 0.5	133V	0.13 ± 0.04	3.42 ± 0.92
WFC 0.5	170 – 200V	0.19 ± 0.04	4.18 ± 1.13
WFC 0.5	240V	0.19 ± 0.05	4.94 ± 1.33
WFC 0.5	275 – 300V	0.25 ± 0.07	6.46 ± 1.74
WFC 0.5	380V	0.31 ± 0.08	7.98 ± 2.15
WFC 0.5	430V	0.34 ± 0.09	8.74 ± 2.36
WFC 0.5	460V	0.37 ± 0.10	9.5 ± 2.57
WFC 0.5	500V	0.44 ± 0.13	11.10 ± 3.31
WFC 0.5	550V	0.44 ± 0.13	11.10 ± 3.31
WFC 0.5	650V	0.55 ± 0.15	14.06 ± 3.8
WFC 0.5	750V	0.60 ± 0.19	15.58 ± 4.7
WFC 0.5	1100V	0.85 ± 0.26	21.70 ± 6.5
WFC 1	100V	0.10 ± 0.02	2.66 ± 0.51
WFC 1	133V	0.13 ± 0.04	3.42 ± 0.92
WFC 1	170 – 200V	0.19 ± 0.04	4.18 ± 1.13
WFC 1	240V	0.19 ± 0.05	4.94 ± 1.33
WFC 1	275 – 300V	0.25 ± 0.07	6.46 ± 1.74
WFC 1	380V	0.31 ± 0.08	7.98 ± 2.15
WFC 1	430V	0.34 ± 0.09	8.74 ± 2.36
WFC 1	460V	0.37 ± 0.10	9.50 ± 2.57
WFC 1	500V	0.44 ± 0.13	11.10 ± 3.31
WFC 1	550V	0.44 ± 0.13	11.10 ± 3.31
WFC 1	650V	0.55 ± 0.15	14.06 ± 3.8
WFC 1	750V	0.6 ± 0.19	15.58 ± 4.7
WFC 1	1100V	0.85 ± 0.26	21.70 ± 6.5
WFC 1.5	76V	0.08 ± 0.02	1.90 ± 0.51
WFC 1.5	100V	0.10 ± 0.02	2.66 ± 0.51
WFC 1.5	133V	0.13 ± 0.04	3.42 ± 0.92
WFC 1.5	170 – 200V	0.19 ± 0.04	4.18 ± 1.13
WFC 1.5	240V	0.19 ± 0.05	4.94 ± 1.33
WFC 1.5	275 – 300V	0.25 ± 0.07	6.46 ± 1.74
WFC 1.5	380V	0.31 ± 0.08	7.98 ± 2.15
WFC 1.5	430V	0.34 ± 0.09	8.74 ± 2.36
WFC 1.5	460V	0.37 ± 0.10	9.50 ± 2.57
WFC 1.5	500V	0.44 ± 0.13	11.10 ± 3.31
WFC 1.5	550V	0.44 ± 0.13	11.10 ± 3.31
WFC 1.5	650 V	0.55 ± 0.15	14.06 ± 3.8
WFC 1.5	750V	0.6 ± 0.19	15.58 ± 4.7
WFC 1.5	1100V	0.85 ± 0.26	21.70 ± 6.5

Series Type	Voltage (VDC)	Inches	mm
WFCA	12 – 30V	0.05 ± 0.01	1.14 ± 0.31
WFCA	42 – 76V	0.08 ± 0.02	1.90 ± 0.51
WFCA	100V	0.10 ± 0.02	2.66 ± 0.51
WFCA	133V	0.13 ± 0.04	3.42 ± 0.92
WFCA	170 – 200V	0.19 ± 0.04	4.18 ± 1.13
WFCA	240V	0.19 ± 0.05	4.94 ± 1.33
WFCA	275-300V	0.25 ± 0.07	6.46 ± 1.74
WFCA	380V	0.31 ± 0.08	7.98 ± 2.15
WFCA	430V	0.34 ± 0.09	8.74 ± 2.36
WFCA	460V	0.37 ± 0.10	9.5 ± 2.57
WFCA	500V	0.44 ± 0.13	11.10 ± 3.31
WFCA	550V	0.44 ± 0.13	11.10 ± 3.31
WFCA	650V	0.55 ± 0.15	14.06 ± 3.8
WFCA	750V	0.6 ± 0.19	15.58 ± 4.7
WFCA	1100V	0.85 ± 0.26	21.70 ± 6.5
WFCB	12 – 20V	0.05 ± 0.01	1.14 ± 0.31
WFCB	25 – 30V	0.08 ± 0.02	1.90 ± 0.51
WFCB	42 – 58V	0.10 ± 0.02	2.66 ± 0.72
WFCB	66V	0.13 ± 0.04	3.42 ± 0.92
WFCB	76V	0.19 ± 0.04	4.18 ± 1.13
WFCB	100V	0.19 ± 0.05	4.94 ± 1.33
WFCB	133V	0.22 ± 0.07	5.70 ± 1.71
WFCB	170V	0.28 ± 0.09	7.22 ± 2.17
WFCB	190V	0.31 ± 0.09	7.98 ± 2.39
WFCB	200V	0.34 ± 0.10	8.74 ± 2.62
WFCB	240V	0.37 ± 0.11	9.50 ± 2.85
WFCB	275V	0.43 ± 0.13	11.02 ± 3.31
WFCB	300V	0.46 ± 0.14	11.78 ± 3.53
WFCB	380V	0.58 ± 0.18	14.82 ± 4.45
WFCC	12V	0.05 ± 0.01	1.14 ± 0.31
WFCC	15V	0.08 ± 0.02	1.90 ± 0.51
WFCC	20 – 25V	0.10 ± 0.02	2.66 ± 0.72
WFCC	30V	0.13 ± 0.04	3.42 ± 0.92
WFCC	42V	0.19 ± 0.05	4.94 ± 1.33
WFCC	58V	0.22 ± 0.06	5.70 ± 1.54
WFCC	66V	0.19 ± 0.06	4.94 ± 1.48
WFCC	76V	0.25 ± 0.08	6.46 ± 1.94
WFCC	100V	0.31 ± 0.09	7.98 ± 2.39
WFCC	133V	0.40 ± 0.12	10.26 ± 3.08
WFCC	170V	0.50 ± 0.15	12.54 ± 3.76
WFCC	190V	0.50 ± 0.16	13.3 ± 3.99
WFCC	200V	0.31 ± 0.09	7.98 ± 2.39

WFC Series**Package Dimensions (continued)****Cell and Stack Series**

Series Type	Voltage (VDC)	Inches	mm
WFCD	12 – 15V	0.04 ± 0.01	1.14 ± 0.34
WFCD	20 - 30V	0.07 ± 0.02	1.90 ± 0.57
WFCD	42V	0.10 ± 0.03	2.66 ± 0.8
WFCD	58V	0.13 ± 0.04	3.42 ± 1.03
WFCD	66V	0.16 ± 0.05	4.18 ± 1.25
WFCD	76V	0.19 ± 0.06	4.94 ± 1.48
WFCD	100V	0.22 ± 0.07	5.70 ± 1.71
WFCD	133V	0.28 ± 0.08	7.22 ± 2.17
WFCD	170V	0.34 ± 0.10	8.74 ± 2.62
WFCD	190V	0.37 ± 0.11	9.50 ± 2.85
WFCD	200V	0.40 ± 0.12	10.26 ± 3.08
WFCE	12V	0.04 ± 0.01	1.14 ± 0.34
WFCE	15 – 20V	0.07 ± 0.02	1.90 ± 0.57
WFCE	25 – 30V	0.10 ± 0.03	2.66 ± 0.80
WFCE	42V	0.13 ± 0.04	3.42 ± 1.03
WFCE	58 – 66V	0.19 ± 0.06	4.94 ± 1.48
WFCE	76V	0.22 ± 0.07	5.70 ± 1.71
WFCE	100V	0.31 ± 0.09	7.98 ± 2.39
WFCE	133V	0.40 ± 0.12	10.26 ± 3.08

WFC Series Electrical Characteristics

Part Number			Rated Standoff Voltage		Breakdown Voltage	Test Current	Current Rating	Maximum Clamping Voltage	Reverse Leakage
General Lead Series	Cell Series	Stack Series	VAC (V)	VDC (V)	VBR (V) MIN. @IT	IT (mA)	Rated IPP measured with 8/20µS pulse	VC(V) @IPP	IR (µA) @ VDC
WFC 0.5									
WFC 0.5-133L	WFC 0.5-133C	WFC 0.5-133S	100	133	147.0	1.0	0.5KA	220.0	20
WFC 0.5-170L	WFC 0.5-170C	WFC 0.5-170S	130	170	180.0	1.0	0.5KA	260.0	20
WFC 0.5-190L	WFC 0.5-190C	WFC 0.5-190S	145	190	200.0	1.0	0.5KA	290.0	20
WFC 0.5-200L	WFC 0.5-200C	WFC 0.5-200S	150	200	222.0	1.0	0.5KA	330.0	20
WFC 0.5-240L	WFC 0.5-240C	WFC 0.5-240S	180	240	250.0	1.0	0.5KA	340.0	20
WFC 0.5-275L	WFC 0.5-275C	WFC 0.5-275S	210	275	300.0	1.0	0.5KA	435.0	20
WFC 0.5-300L	WFC 0.5-300C	WFC 0.5-300S	230	300	330.0	1.0	0.5KA	470.0	20
WFC 0.5-380L	WFC 0.5-380C	WFC 0.5-380S	275	380	401.0	1.0	0.5KA	520.0	20
WFC 0.5-430L	WFC 0.5-430C	WFC 0.5-430S	310	430	440.0	1.0	0.5KA	625.0	20
WFC 0.5-460L	WFC 0.5-460C	WFC 0.5-460S	330	460	500.0	1.0	0.5KA	770.0	20
WFC 0.5-500L	WFC 0.5-500C	WFC 0.5-500S	350	500	558.0	1.0	0.5KA	868.0	20
WFC 0.5-550L	WFC 0.5-550C	WFC 0.5-550S	380	550	570.0	1.0	0.5KA	950.0	20
WFC 0.5-650L	WFC 0.5-650C	WFC 0.5-650S	460	650	680.0	1.0	0.5KA	1000.0	20
WFC 0.5-750L	WFC 0.5-750C	NA	530	750	770.0	1.0	0.5KA	1100.0	20
WFC 0.5-1100L	WFC 0.5-1100C	NA	840	1200	1300.0	1.0	0.5KA	2000.0	20
WFC 1									
WFC 1-100L	WFC 1-100C	WFC 1-100S	72	100	110.0	1.0	1.0KA	165.0	20
WFC 1-133L	WFC 1-133C	WFC 1-133S	100	133	147.0	1.0	1.0KA	220.0	20
WFC 1-170L	WFC 1-170C	WFC 1-170S	130	170	180.0	1.0	1.0KA	260.0	20
WFC 1-190L	WFC 1-190C	WFC 1-190S	145	190	200.0	1.0	1.0KA	290.0	20
WFC 1-200L	WFC 1-200C	WFC 1-200S	150	200	222.0	1.0	1.0KA	330.0	20
WFC 1-240L	WFC 1-240C	WFC 1-240S	180	240	250.0	1.0	1.0KA	340.0	20
WFC 1-275L	WFC 1-275C	WFC 1-275S	210	275	300.0	1.0	1.0KA	435.0	20
WFC 1-300L	WFC 1-300C	WFC 1-300S	230	300	330.0	1.0	1.0KA	470.0	20
WFC 1-380L	WFC 1-380C	WFC 1-380S	275	380	401.0	1.0	1.0KA	520.0	20
WFC 1-430L	WFC 1-430C	WFC 1-430S	310	430	440.0	1.0	1.0KA	625.0	20
WFC 1-460L	WFC 1-460C	WFC 1-460S	330	460	500.0	1.0	1.0KA	770.0	20
WFC 1-500L	WFC 1-500C	NA	350	500	558.0	1.0	1.0KA	868.0	20
WFC 1-550L	WFC 1-550C	NA	380	550	570.0	1.0	1.0KA	950.0	20
WFC 1-650L	WFC 1-650C	NA	460	650	680.0	1.0	1.0KA	1000.0	20
WFC 1-750L	WFC 1-750C	NA	530	750	770.0	1.0	1.0KA	1100.0	20
WFC 1-1100L	WFC 1-1100C	NA	840	1200	1300.0	1.0	1.0KA	2000.0	20
WFC 1.5									
WFC 1.5-076L	WFC 1.5-076C	WFC 1.5-076S	54	76	85.0	1.0	1.5KA	140.0	20
WFC 1.5-100L	WFC 1.5-100C	WFC 1.5-100S	72	100	110.0	1.0	1.5KA	165.0	20
WFC 1.5-133L	WFC 1.5-133C	WFC 1.5-133S	100	133	147.0	1.0	1.5KA	220.0	20
WFC 1.5-170L	WFC 1.5-170C	WFC 1.5-170S	130	170	180.0	1.0	1.5KA	260.0	20
WFC 1.5-190L	WFC 1.5-190C	WFC 1.5-190S	145	190	200.0	1.0	1.5KA	290.0	20
WFC 1.5-200L	WFC 1.5-200C	WFC 1.5-200S	150	200	222.0	1.0	1.5KA	330.0	20
WFC 1.5-240L	WFC 1.5-240C	WFC 1.5-240S	180	240	250.0	1.0	1.5KA	340.0	20
WFC 1.5-275L	WFC 1.5-275C	WFC 1.5-275S	210	275	300.0	1.0	1.5KA	435.0	20
WFC 1.5-300L	WFC 1.5-300C	WFC 1.5-300S	230	300	330.0	1.0	1.5KA	470.0	20
WFC 1.5-380L	WFC 1.5-380C	WFC 1.5-380S	275	380	401.0	1.0	1.5KA	520.0	20
WFC 1.5-430L	WFC 1.5-430C	WFC 1.5-430S	310	430	440.0	1.0	1.5KA	625.0	20
WFC 1.5-460L	WFC 1.5-460C	WFC 1.5-460S	330	460	500.0	1.0	1.5KA	770.0	20
WFC 1.5-500L	WFC 1.5-500C	NA	350	500	558.0	1.0	1.5KA	868.0	20
WFC 1.5-550L	WFC 1.5-550C	NA	380	550	570.0	1.0	1.5KA	950.0	20
WFC 1.5-650L	WFC 1.5-650C	NA	460	650	680.0	1.0	1.5KA	1000.0	20
WFC1.5-750L	WFC1.5-750C	NA	530	750	770.0	1.0	1.5KA	1100.0	20
WFC1.5-1100L	WFC1.5-1100C	NA	770	1100	1200	1.0	1.5KA	2000.0	20

*SEE NOTES ON PAGE 50.

TVS DIODES

WFC Series Electrical Characteristics (continued)

Part Number			Rated Standoff Voltage		Breakdown Voltage	Test Current	Current Rating	Maximum Clamping Voltage	Reverse Leakage
General Lead Series	Cell Series	Stack Series	VAC (V)	VDC (V)	VBR (V) MIN. @IT	IT (mA)	Rated IPP measured with 8/20µS pulse	VC(V) @IPP	IR (µA) @ VDC
WFCA									
WFCA-012L*	WFCA-012C*	WFCA-012S*	8.5	12	14.0	1.0	3KA	28.0	20
WFCA-015L*	WFCA-015C*	WFCA-015S*	11	15	17.0	1.0	3KA	30.0	20
WFCA-020L*	WFCA-020C*	WFCA-020S*	14	20	22.0	1.0	3KA	40.0	20
WFCA-025L*	WFCA-025C*	WFCA-025S*	17	25	28.0	1.0	3KA	50.0	20
WFCA-030L*	WFCA-030C*	WFCA-030S*	21	30	33.0	1.0	3KA	60.0	20
WFCA-042L*	WFCA-042C*	WFCA-042S*	30	42	47.0	1.0	3KA	77.0	20
WFCA-058L*	WFCA-058C*	WFCA-058S*	40	58	64.0	1.0	3KA	110.0	20
WFCA-066L*	WFCA-066C*	WFCA-066S*	45	66	70.0	1.0	3KA	125.0	20
WFCA-076L*	WFCA-076C*	WFCA-076S*	54	76	85.0	1.0	3KA	140.0	20
WFCA-100L*	WFCA-100C*	WFCA-100S*	72	100	110.0	1.0	3KA	165.0	20
WFCA-133L*	WFCA-133C*	WFCA-133S*	100	133	147.0	1.0	3KA	220.0	20
WFCA-170L*	WFCA-170C*	WFCA-170S*	130	170	180.0	1.0	3KA	260.0	20
WFCA-190L*	WFCA-190C*	WFCA-190S*	145	190	200.0	1.0	3KA	290.0	20
WFCA-200L*	WFCA-200C*	WFCA-200S*	150	200	222.0	1.0	3KA	330.0	20
WFCA-240L	WFC 0.5-240C	WFCA-240S	180	240	250.0	1.0	3KA	340.0	20
WFCA-275L	WFCA-275C	NA	210	275	300.0	1.0	3KA	435.0	20
WFCA-300L	WFCA-300C	NA	230	300	330.0	1.0	3KA	470.0	20
WFCA-380L	WFCA-380C	NA	275	380	401.0	1.0	3KA	520.0	20
WFCA-430L	WFCA-430C	NA	310	430	440.0	1.0	3KA	625.0	20
WFCA-460L	WFCA-460C	NA	330	460	500.0	1.0	3KA	770.0	20
WFCA-500L	WFCA-500C	NA	350	500	558.0	1.0	3KA	868.0	20
WFCA-550L	WFCA-550C	NA	380	550	570.0	1.0	3KA	950.0	20
WFCA-650L	WFCA-650C	NA	460	650	680.0	1.0	3KA	1000.0	20
WFCA-750L	WFCA-750C	NA	530	750	770.0	1.0	3KA	1100.0	20
WFCA-1100L	WFCA-1100C	NA	770	1100	1200	1.0	3KA	2000.0	20
WFCB									
WFCB-012L*	WFCB-012C*	WFCB-012S*	8.5	12	14.0	1.0	6KA	28.0	20
WFCB-015L*	WFCB-015C*	WFCB-015S*	11	15	17.0	1.0	6KA	30.0	20
WFCB-020L*	WFCB-020C*	WFCB-020S*	14	20	22.0	1.0	6KA	40.0	20
WFCB-025L*	WFCB-025C*	WFCB-025S*	17	25	28.0	1.0	6KA	50.0	20
WFCB-030L*	WFCB-030C*	WFCB-030S*	21	30	33.0	1.0	6KA	60.0	20
WFCB-042L*	WFCB-042C*	WFCB-042S*	30	42	47.0	1.0	6KA	77.0	20
WFCB-058L*	WFCB-058C*	WFCB-058S*	40	58	64.0	1.0	6KA	110.0	20
WFCB-066L*	WFCB-066C*	WFCB-066S*	45	66	70.0	1.0	6KA	125.0	20
WFCB-076L*	WFCB-076C*	WFCB-076S*	54	76	83.0	1.0	6KA	135.0	20
WFCB-100L*	WFCB-100C*	WFCB-100S*	72	100	110.0	1.0	6KA	165.0	20
WFCB-133L*	WFCB-133C*	NA	100	133	147.0	1.0	6KA	220.0	20
WFCB-170L*	WFCB-170C*	NA	130	170	180.0	1.0	6KA	260.0	20
WFCB-190L*	WFCB-190C*	NA	145	190	200.0	1.0	6KA	290.0	20
WFCB-200L*	WFCB-200C*	NA	150	200	222.0	1.0	6KA	330.0	20
WFCB-240L*	WFCB-240C*	NA	180	240	250.0	1.0	6KA	340.0	20
WFCB-275L*	WFCB-275C*	NA	210	275	300.0	1.0	6KA	435.0	20
WFCB-300L*	WFCB-300C*	NA	230	300	330.0	1.0	6KA	470.0	20
WFCB-380L*	WFCB-380C*	NA	275	380	401.0	1.0	6KA	520.0	20

***SEE NOTES ON PAGE 50.**

WFC Series Electrical Characteristics (continued)

Part Number			Rated Standoff Voltage		Breakdown Voltage	Test Current	Current Rating	Maximum Clamping Voltage	Reverse Leakage
General Lead Series	Cell Series	Stack Series	VAC (V)	VDC (V)	VBR (V) MIN. @IT	IT (mA)	Rated IPP measured with 8/20µS pulse	VC(V) @IPP	IR (µA) @ VDC
WFCC									
WFCC-012L*	WFCC-012C*	WFCC-012S*	8.5	12	14.0	1.0	10KA	28.0	20
WFCC-015L	WFCC-015C	WFCC-015S	11	15	17.0	1.0	10KA	30.0	20
WFCC-020L*	WFCC-020C*	WFCC-020S*	14	20	22.0	1.0	10KA	40.0	20
WFCC-025L	WFCC-025C	WFCC-025S	17	25	28.0	1.0	10KA	50.0	20
WFCC-030L*	WFCC-030C*	WFCC-030S*	21	30	33.0	1.0	10KA	60.0	20
WFCC-042L*	WFCC-042C*	WFCC-042S*	30	42	47.0	1.0	10KA	77.0	20
WFCC-058L*	WFCC-058C*	WFC-058S*	40	58	64.0	1.0	10KA	110.0	20
WFCC-066L*	WFCC-066C*	NA	45	66	70.0	1.0	10KA	125.0	20
WFCC-076L*	WFCC-076C*	NA	54	76	83.0	1.0	10KA	135.0	20
WFCC-100L*	WFCC-100C*	NA	72	100	110.0	1.0	10KA	165.0	20
WFCC-133L*	WFCC-133C*	NA	100	133	147.0	1.0	10KA	220.0	20
WFCC-170L*	WFCC-170C*	NA	130	170	180.0	1.0	10KA	260.0	20
WFCC-190L*	WFCC-190C*	NA	145	190	200.0	1.0	10KA	290.0	20
WFCC-200L	WFCC-200C	NA	150	200	222.0	1.0	10KA	330.0	20
WFCD									
WFCD-012L	WFCD-012C	NA	8.5	12	14.0	1.0	16KA	28.0	20
WFCD-015L*	WFCD-015C*	NA	11	15	17.0	1.0	16KA	30.0	20
WFCD-020L	WFCD-020C	NA	14	20	22.0	1.0	16KA	40.0	20
WFCD-025L*	WFCD-025C*	NA	17	25	28.0	1.0	16KA	50.0	20
WFCD-030L*	WFCD-030C*	NA	21	30	33.0	1.0	16KA	60.0	20
WFCD-042L*	WFCD-042C*	NA	30	42	47.0	1.0	16KA	77.0	20
WFCD-058L*	WFCD-058C*	NA	40	58	64.0	1.0	16KA	110.0	20
WFCD-066L*	WFCD-066C*	NA	45	66	70.0	1.0	16KA	125.0	20
WFCD-076L*	WFCD-076C*	NA	54	76	85.0	1.0	16KA	135.0	20
WFCD-100L*	WFCD-100C*	NA	72	100	110.0	1.0	16KA	165.0	20
WFCD-133L*	WFCD-133C*	NA	100	133	147.0	1.0	16KA	220.0	20
WFCD-170L*	WFCD-170C*	NA	130	170	180.0	1.0	16KA	260.0	20
WFCD-190L*	WFCD-190C*	NA	145	190	200.0	1.0	16KA	290.0	20
WFCD-200L	WFCD-200C	NA	150	200	222.0	1.0	16KA	330.0	20
WFCE									
WFCE-012L	WFCE-012C	NA	8.5	12	14.0	1.0	20KA	28.0	20
WFCE-015L	WFCE-015C	NA	11	15	17.0	1.0	20KA	30.0	20
WFCE-020L	WFCE-020C	NA	14	20	22.0	1.0	20KA	40.0	20
WFCE-025L	WFCE-025C	NA	17	25	28.0	1.0	20KA	50.0	20
WFCE-030L	WFCE-030C	NA	21	30	33.0	1.0	20KA	60.0	20
WFCE-042L	WFCE-042C	NA	30	42	47.0	1.0	20KA	77.0	20
WFCE-058L	WFCE-058C	NA	40	58	64.0	1.0	20KA	110.0	20
WFCE-066L	WFCE-066C	NA	45	66	70.0	1.0	20KA	125.0	20
WFCE-076L	WFCE-076C	NA	54	76	85.0	1.0	20KA	135.0	20
WFCE-100L	WFCE-100C	NA	72	100	110.0	1.0	20KA	165.0	20
WFCE-133L	WFCE-133C	NA	100	133	147.0	1.0	20KA	220.0	20

NOTES:

1. Ta=25°C unless otherwise specified.
2. Using 8/20 us wave shape pulses as defined in IEC61000-4-5.

*UL1449 3rd Edition Recognized, File #E321567.

THESE NOTES APPLY TO ALL PARTS ON PAGES 42-49 OF THIS CATALOG (WFC SERIES).

WFC Series

FLOW/WAVE SOLDERING RECOMMENDATION PARAMETERS

Flow/wave Soldering

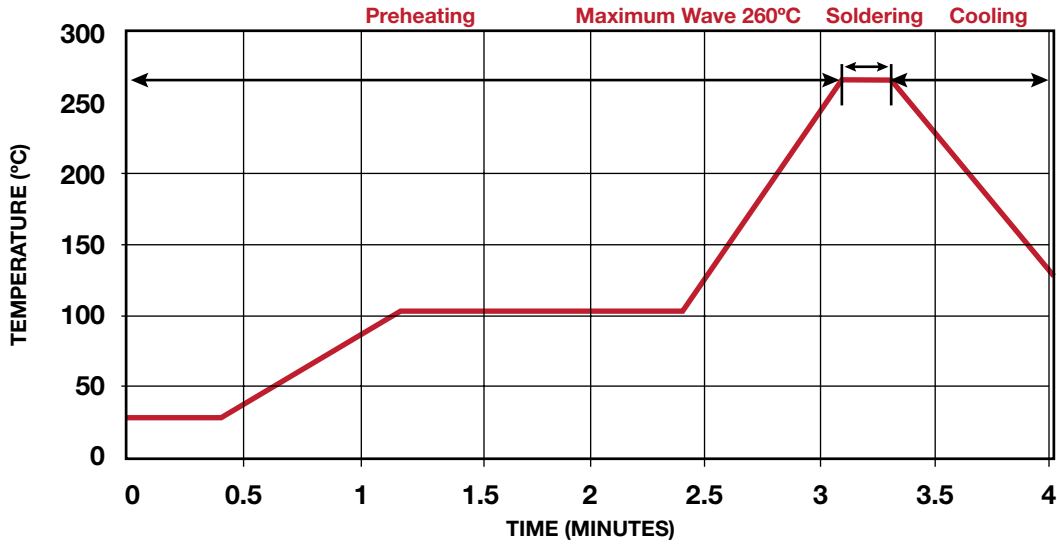

Peak Temperature: 265°C
 Dipping Time: 10 seconds
 Soldering: 1 time

PEAK POWER DERATING

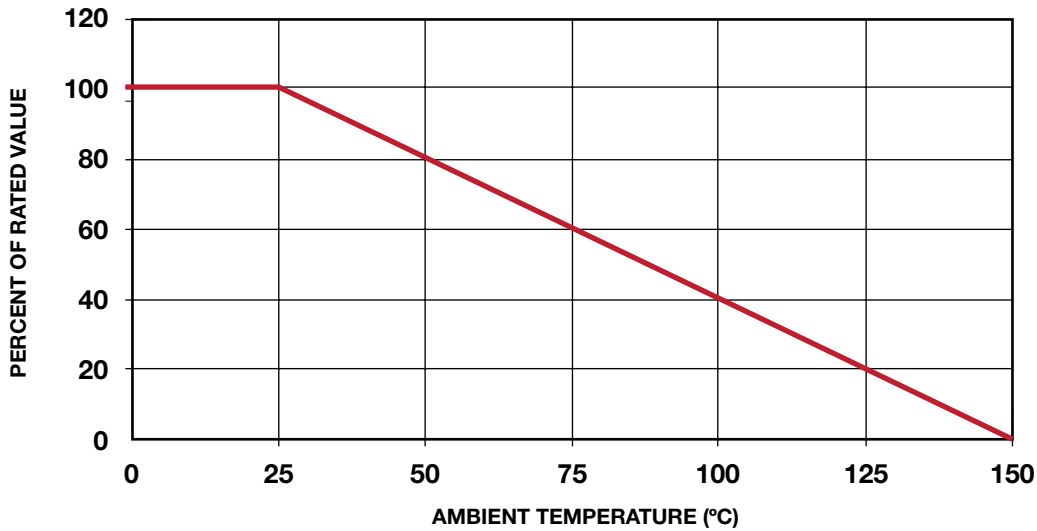

P4SMAJ Series – 400 Watt Surface Mount



P4SMAJ Series Features

- RoHS Compliance Standard
- 400 watt peak pulse power dissipation
- Available in voltages from 5.0V to 440V
- Unidirectional and bidirectional
- Glass passivated junction
- Low clamping factor
- Available in tape and reel (Reel quantity = 5,000 pieces)
- Each device 100% surge tested
- Tape and Reel to EIA Standard RS - 481 - A
- UL 497B Recognized, File #E135015
- AEC-Q101 Qualified (8.0A & 8.0CA – 440A & 440CA) types. (When ordering ADD suffix “Z” to end of part number.)

Absolute Maximum Ratings

Parameter	Value
Peak pulse power dissipation (PPPM) at 25°C	400W
Operating and storage temperatures	-55°C to + 150°C

Mechanical Characteristics

- DO214AC package
- UL94V-0 Thermoset Epoxy
- Solder plated terminals
- Solderable per MIL-STD-750 Method 2026

Mechanical Dimensions

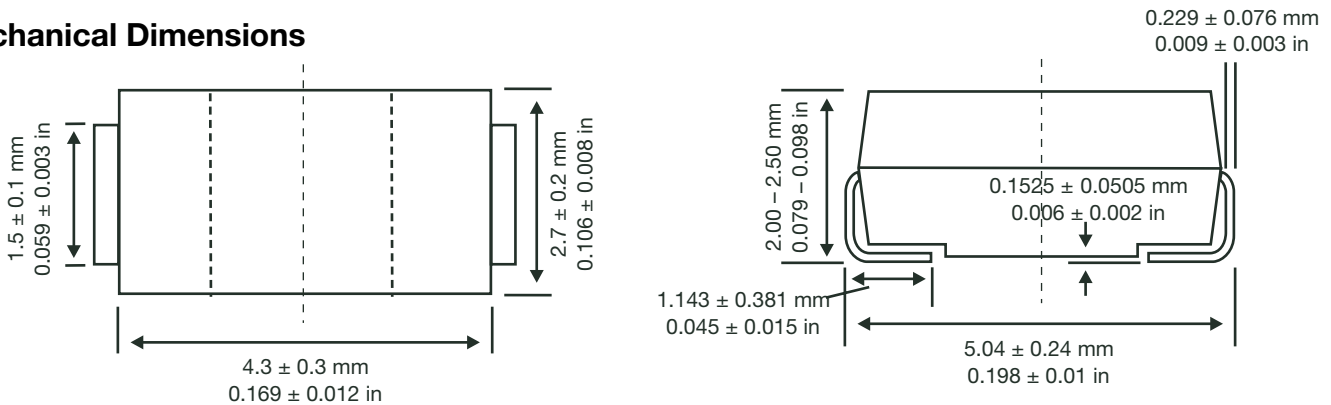

Standard Mounting Pad Layout

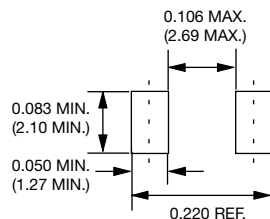

All dimensions in inches and (millimeters)

P4SMAJ Series – 400 Watt Surface Mount (continued)

Electrical Characteristics

Part Number*	Uni Part Marking**	Bi Part Marking**	Rated Standoff Voltage V _{wm}	Breakdown Voltage			Maximum Stand By Current @V _{WM} + I _d	10/1000 μ s Maximum Clamping Voltage @I _{ppm} # V _c Max	10/1000 μ s Rated Peak Impulse Current I _{ppm} #
				V _{br} (Volts)		@I _t			
				(Volts)	Min	Max			
P4SMAJ5.0	HD	TD	5	6.4	7.3	10	800	9.6	41.6
P4SMAJ5.0A	HE/AE	TE/WE	5	6.4	7	10	800	9.2	43.5
P4SMAJ6.0	HF	TF	6	6.67	8.15	10	800	11.4	35.1
P4SMAJ6.0A	HG/AG	TG/WG	6	6.67	7.37	10	800	10.3	38.8
P4SMAJ6.5	HH	TH	6.5	7.22	8.82	10	500	12.3	32.5
P4SMAJ6.5A	HK/AK	TK/WK	6.5	7.22	7.98	10	500	11.2	35.7
P4SMAJ7.0	HL	TL	7	7.78	9.51	10	200	13.3	30.1
P4SMAJ7.0A	HM/AM	TM/WM	7	7.78	8.6	10	200	12	33.3
P4SMAJ7.5	HN	TN	7.5	8.33	10.3	1	100	14.3	28
P4SMAJ7.5A	HP/AP	TP/WP	7.5	8.33	9.21	1	100	12.9	31
P4SMAJ8.0	HQ	TQ	8	8.89	10.9	1	50	15	26.5
P4SMAJ8.0A	HR/AR	TR/WR	8	8.89	9.83	1	50	13.6	29.4
P4SMAJ8.5	HS	TS	8.5	9.44	11.5	1	20	15.9	25.1
P4SMAJ8.5A	HT/AT	TT/WT	8.5	9.44	10.4	1	20	14.4	27.8
P4SMAJ9.0	HU	TU	9	10	12.2	1	10	16.9	23.6
P4SMAJ9.0A	HV/AV	TV/WV	9	10	11.1	1	10	15.4	26
P4SMAJ10	HW	TW	10	11.1	13.6	1	5	18.8	21.2
P4SMAJ10A	HX/AX	TX/WX	10	11.1	12.3	1	5	17	23.5
P4SMAJ11	HY	TY	11	12.2	14.9	1	1	20.1	20
P4SMAJ11A	HZ/AZ	TZ/WZ	11	12.2	13.5	1	1	18.2	22
P4SMAJ12	ID	UD	12	13.3	16.3	1	1	22	18.1
P4SMAJ12A	IE/BE	UE/XE	12	13.3	14.7	1	1	19.9	20.1
P4SMAJ13	IF	UF	13	14.4	17.6	1	1	23.8	16.8
P4SMAJ13A	IG/BG	UG/XG	13	14.4	15.9	1	1	21.5	18.6
P4SMAJ14	IH	UH	14	15.6	19.1	1	1	25.8	15.5
P4SMAJ14A	IK/BK	UK/XK	14	15.6	17.2	1	1	23.2	17.2

* = Add "C" or "CA" suffix for bidirectional device types.

** = There may be two potential codes depending on factory designation.

+ = For Bidirectional Types Having V_{WM} <= 10V, their I_D limit is doubled.

= See General Information for Impulse Current Waveform.

P4SMAJ Series – 400 Watt Surface Mount (continued)**Electrical Characteristics (continued)**

Part Number*	Uni Part Marking**	Bi Part Marking**	Rated Standoff Voltage Vwm	Breakdown Voltage			Maximum Stand By Current @VWM+ Id	10/1000µs Maximum Clamping Voltage @Ippm# Vc Max	10/1000µs Rated Peak Impulse Current Ippm#
				Vbr (Volts)		@It			
				(Volts)	Min	Max			
P4SMAJ15	IL	UL	15	16.7	20.4	1	1	26.9	14.8
P4SMAJ15A	IM/BM	UM/XM	15	16.7	18.5	1	1	24.4	16.4
P4SMAJ16	IN	UN	16	17.8	21.8	1	1	28.8	13.8
P4SMAJ16A	IP/BP	UP/XP	16	17.8	19.7	1	1	26	15.4
P4SMAJ17	IQ	UQ	17	18.9	23.1	1	1	30.5	13.1
P4SMAJ17A	IR/BR	UR/XR	17	18.9	20.9	1	1	27.6	14.5
P4SMAJ18	IS	US	18	20	24.4	1	1	32.2	12.4
P4SMAJ18A	IT/BT	UT/XT	18	20	22.1	1	1	29.2	13.7
P4SMAJ20	IU	UU	20	22.2	27.1	1	1	35.8	11.1
P4SMAJ20A	IV/BV	UV/XV	20	22.2	24.5	1	1	32.4	12.3
P4SMAJ22	IW	UW	22	24.4	29.8	1	1	39.4	10.1
P4SMAJ22A	IX/BX	UX/XX	22	24.4	26.9	1	1	35.5	11.3
P4SMAJ24	IY	UY	24	26.7	32.6	1	1	43	9.3
P4SMAJ24A	IZ/BZ	UZ/XZ	24	26.7	29.5	1	1	38.9	10.3
P4SMAJ26	JD	VD	26	28.9	35.3	1	1	46.6	8.6
P4SMAJ26A	JE/CE	VE/YE	26	28.9	31.9	1	1	42.1	9.5
P4SMAJ28	JF	VF	28	31.1	38	1	1	50	8
P4SMAJ28A	JG/CG	VG/YG	28	31.1	34.4	1	1	45.4	8.8
P4SMAJ30	JH	VH	30	33.3	40.7	1	1	53.5	7.5
P4SMAJ30A	JK/CK	VK/YK	30	33.3	36.8	1	1	48.4	8.3
P4SMAJ33	JL	VL	33	36.7	44.9	1	1	59	6.8
P4SMAJ33A	JM/CM	VM/YM	33	36.7	40.6	1	1	53.3	7.5
P4SMAJ36	JN	VN	36	40	48.9	1	1	64.3	6.2
P4SMAJ36A	JP/CP	VP/YP	36	40	44.2	1	1	58.1	6.9
P4SMAJ40	JQ	VQ	40	44.4	54.3	1	1	71.4	5.6
P4SMAJ40A	JR/CR	VR/YR	40	44.4	49.1	1	1	64.5	6.2

* = Add "C" or "CA" suffix for bidirectional device types.

** = There may be two potential codes depending on factory designation.

+ = For Bidirectional Types Having VWM <= 10V, their ID limit is doubled.

= See General Information for Impulse Current Waveform.

P4SMAJ Series – 400 Watt Surface Mount (continued)**Electrical Characteristics (continued)**

Part Number*	Uni Part Marking**	Bi Part Marking**	Rated Standoff Voltage Vwm	Breakdown Voltage			Maximum Stand By Current @VWM+ Id	10/1000µs Maximum Clamping Voltage @Ippm# Vc Max	10/1000µs Rated Peak Impulse Current Ippm#
				Vbr (Volts)		@It			
				(Volts)	Min	Max			
P4SMAJ43	JS	VS	43	47.8	58.4	1	1	76.7	5.2
P4SMAJ43A	JT/CT	VT/YT	43	47.8	52.8	1	1	69.4	5.8
P4SMAJ45	JU	VU	45	50	61.1	1	1	80.3	5.0
P4SMAJ45A	JV/CV	VV/YV	45	50	55.3	1	1	72.7	5.5
P4SMAJ48	JW	VW	48	53.3	65.1	1	1	85.5	4.7
P4SMAJ48A	JX/CX	VX/YX	48	53.3	58.9	1	1	77.4	5.2
P4SMAJ51	JY	VY	51	56.7	69.3	1	1	91.1	4.4
P4SMAJ51A	JZ/CZ	VZ/YZ	51	56.7	62.7	1	1	82.4	4.9
P4SMAJ54	RD	WD	54	60	73.3	1	1	96.3	4.2
P4SMAJ54A	RE	WE/ZE	54	60	66.3	1	1	87.1	4.6
P4SMAJ58	RF	WF	58	64.4	78.7	1	1	103	3.9
P4SMAJ58A	RG	WG/ZG	58	64.4	71.2	1	1	93.6	4.3
P4SMAJ60	RH	WH	60	66.7	81.5	1	1	107	3.7
P4SMAJ60A	RK	WK/ZK	60	66.7	73.7	1	1	96.8	4.1
P4SMAJ64	RL	WL	64	71.1	86.4	1	1	114	3.5
P4SMAJ64A	RM	WM/ZM	64	71.1	78.6	1	1	103	3.9
P4SMAJ70	RN	WN	70	77.8	95.1	1	1	125	3.2
P4SMAJ70A	RP	WP/ZP	70	77.8	86	1	1	113	3.5
P4SMAJ75	RQ	WQ	75	83.3	102	1	1	134	3.0
P4SMAJ75A	RR	WR/ZR	75	83.3	92.1	1	1	121	3.3
P4SMAJ78	RS	WS	78	86.7	106	1	1	139	2.9
P4SMAJ78A	RT	WT/ZT	78	86.7	95.8	1	1	126	3.2
P4SMAJ85	RU	WU	85	94.4	115	1	1	151	2.6
P4SMAJ85A	RV	WV/ZV	85	94.4	104	1	1	137	2.9
P4SMAJ90	RW	WW	90	100	122	1	1	160	2.5
P4SMAJ90A	RX	WX/ZX	90	100	111	1	1	146	2.7

* = Add "C" or "CA" suffix for bidirectional device types.

** = There may be two potential codes depending on factory designation.

+ = For Bidirectional Types Having VWM <= 10V, their ID limit is doubled.

= See General Information for Impulse Current Waveform.

P4SMAJ Series – 400 Watt Surface Mount (continued)**Electrical Characteristics (continued)**

Part Number*	Uni Part Marking**	Bi Part Marking**	Rated Standoff Voltage V _{WM}	Breakdown Voltage			Maximum Stand By Current @V _{WM} + I _d	10/1000 μ s Maximum Clamping Voltage @I _{PPM} # V _c Max	10/1000 μ s Rated Peak Impulse Current I _{PPM} #
				V _{br} (Volts)		@I _t			
				(Volts)	Min	Max			
P4SMAJ100	RY	WY	100	111	136	1	1	179	2.2
P4SMAJ100A	RZ	WZ/ZZ	100	111	123	1	1	162	2.5
P4SMAJ110	SD	XD	110	122	149	1	1	196	2
P4SMAJ110A	SE	XE/VE	110	122	135	1	1	177	2.3
P4SMAJ120	SF	XF	120	133	163	1	1	214	1.9
P4SMAJ120A	SG	XG/VG	120	133	147	1	1	193	2.1
P4SMAJ130	SH	XH	130	144	176	1	1	231	1.7
P4SMAJ130A	SK	XK/VK	130	144	159	1	1	209	1.9
P4SMAJ150	SL	XL	150	167	204	1	1	268	1.5
P4SMAJ150A	SM	XM/VM	150	167	185	1	1	243	1.6
P4SMAJ160	SN	XN	160	178	218	1	1	287	1.4
P4SMAJ160A	SP	XP/VP	160	178	197	1	1	259	1.5
P4SMAJ170	SQ	XQ	170	189	231	1	1	304	1.3
P4SMAJ170A	SR	XR/VR	170	189	209	1	1	275	1.5
P4SMAJ180A	ST	VT	180	201	222	1	1	292	1.4
P4SMAJ190A	SU	YU	190	211	233	1	1	308	1.3
P4SMAJ200A	SV	VV	200	224	247	1	1	324	1.2
P4SMAJ210A	SW	YW	210	237	263	1	1	340	1.2
P4SMAJ220A	GE	VX	220	246	272	1	1	356	1.1
P4SMAJ250A	SZ	VZ	250	279	309	1	1	405	1.0
P4SMAJ300A	TE	UE	300	335	371	1	1	486	0.8
P4SMAJ350A	TG	UG	350	391	432	1	1	567	0.7
P4SMAJ400A	TK	UK	400	447	494	1	1	648	0.6
P4SMAJ440A	TM	UM	440	492	543	1	1	713	0.6

* = Add "C" or "CA" suffix for bidirectional device types.

** = There may be two potential codes depending on factory designation.

+ = For Bidirectional Types Having V_{WM} <= 10V, their I_D limit is doubled.

= See General Information for Impulse Current Waveform.



P6SMBJ Series – 600 Watt Surface Mount



P6SMBJ Series Features

- RoHS Compliance Standard
- 600 watt peak pulse power dissipation
- Available in voltages from 5.0V to 440V
- Unidirectional and bidirectional
- Glass passivated junction
- Low clamping factor
- Available in tape and reel (Reel quantity = 3,000 pieces)
- Each device 100% surge tested
- Tape and Reel to EIA Standard RS-481-A
- UL 497B Recognized, File # E135015
- AEC-Q101 Qualified (8.0A & 8.0CA – 440A & 440CA) types. (When ordering ADD suffix “Z” to end of part number.)

Absolute Maximum Ratings

Parameter	Value
Peak pulse power dissipation (PPPM) at 25°C	600W
Steady state power dissipation at 25°C	5W
Operating and storage temperatures	-55°C to + 150°C

Mechanical Characteristics

- DO214AA package
- UL94V-0 Thermoset Epoxy
- Solder plated terminals
- Solderable per MIL-STD-750 Method 2026

Mechanical Dimensions

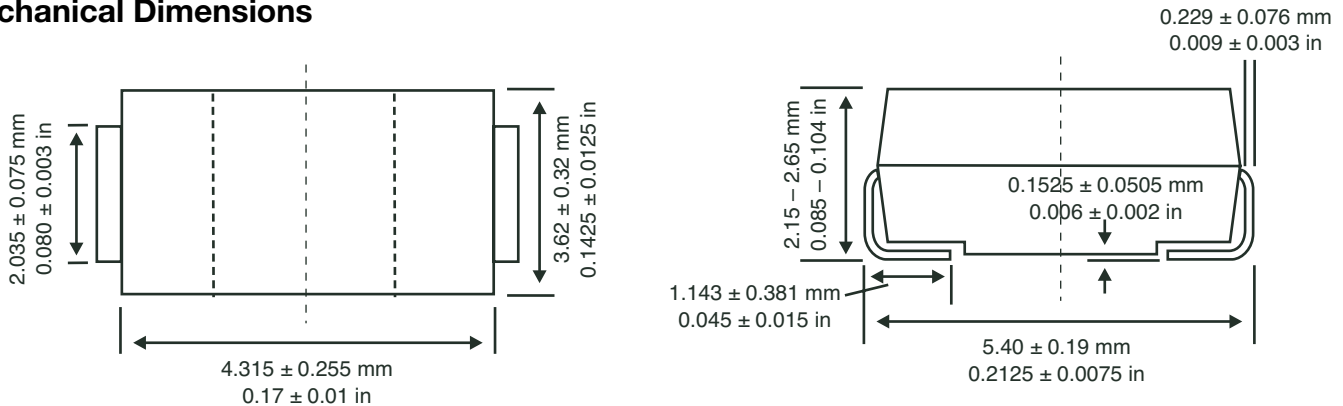

Standard Mounting Pad Layout

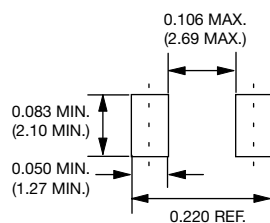

All dimensions in inches and (millimeters)

P6SMBJ Series – 600 Watt Surface Mount (continued)**Electrical Characteristics**

Part Number*	Uni Part Marking	Bi Part Marking	Rated Standoff Voltage V _{wm}	Breakdown Voltage			Maximum Stand By Current @V _{WM} + I _d	10/1000 μ s Maximum Clamping Voltage @I _{ppm} # V _c Max	10/1000 μ s Rated Peak Impulse Current I _{ppm} #
				V _{br} (Volts)		@I _t			
				(Volts)	Min	Max			
P6SMBJ5.0	KD	AD	5	6.4	7.55	10	800	9.6	62.5
P6SMBJ5.0A	KE	AE	5	6.4	7.0	10	800	9.2	65.3
P6SMBJ6.0	KF	AF	6	6.67	8.45	10	800	11.4	52.6
P6SMBJ6.0A	KG	AG	6	6.67	7.37	10	800	10.3	58.3
P6SMBJ6.5	KH	AH	6.5	7.22	9.14	10	500	12.3	48.7
P6SMBJ6.5A	KK	AK	6.5	7.22	7.98	10	500	11.2	53.6
P6SMBJ7.0	KL	AL	7	7.78	9.86	10	200	13.3	45.1
P6SMBJ7.0A	KM	AM	7	7.78	8.6	10	200	12	50
P6SMBJ7.5	KN	AN	7.5	8.33	10.8	1	100	14.3	42
P6SMBJ7.5A	KP	AP	7.5	8.33	9.21	1	100	12.9	46.6
P6SMBJ8.0	KQ	AQ	8	8.89	11.3	1	50	15	40
P6SMBJ8.0A	KR	AR	8	8.89	9.83	1	50	13.6	44.2
P6SMBJ8.5	KS	AS	8.5	9.44	11.9	1	20	15.9	37.7
P6SMBJ8.5A	KT	AT	8.5	9.44	10.4	1	20	14.4	41.7
P6SMBJ9.0	KU	AU	9	10	12.8	1	10	16.9	35.5
P6SMBJ9.0A	KV	AV	9	10	11.1	1	10	15.4	39
P6SMBJ10	KW	AW	10	11.1	14.1	1	5	18.8	31.9
P6SMBJ10A	KX	AX	10	11.1	12.3	1	5	17	35.3
P6SMBJ11	KY	AY	11	12.2	15.4	1	1	20.1	29.9
P6SMBJ11A	KZ	AZ	11	12.2	13.5	1	1	18.2	33
P6SMBJ12	LD	BD	12	13.3	16.9	1	1	22	27.3
P6SMBJ12A	LE	BE	12	13.3	14.7	1	1	19.9	30.2
P6SMBJ13	LF	BF	13	14.4	18.2	1	1	23.8	25.2
P6SMBJ13A	LG	BG	13	14.4	15.9	1	1	21.5	28
P6SMBJ14	LH	BH	14	15.6	19.8	1	1	25.8	23.3
P6SMBJ14A	LK	BK	14	15.6	17.2	1	1	23.2	25.9

* = Add "C" or "CA" suffix for bidirectional device types.

+ = For Bidirectional Types Having V_{WM} <= 10V, their I_D limit is doubled.

= See General Information for Impulse Current Waveform.

P6SMBJ Series – 600 Watt Surface Mount (continued)**Electrical Characteristics (continued)**

Part Number*	Uni Part Marking	Bi Part Marking	Rated Standoff Voltage V _{wm}	Breakdown Voltage			Maximum Stand By Current @V _{WM} + I _d	10/1000 μ s Maximum Clamping Voltage @I _{ppm} # V _c Max	10/1000 μ s Rated Peak Impulse Current I _{ppm} #
				V _{br} (Volts)		@I _t			
				(Volts)	Min	Max			
P6SMBJ15	LL	BL	15	16.7	21.1	1	1	26.9	22.3
P6SMBJ15A	LM	BM	15	16.7	18.5	1	1	24.4	24.6
P6SMBJ16	LN	BN	16	17.8	22.6	1	1	28.8	20.8
P6SMBJ16A	LP	BP	16	17.8	19.7	1	1	26	23.1
P6SMBJ17	LQ	BQ	17	18.9	23.9	1	1	30.5	19.7
P6SMBJ17A	LR	BR	17	18.9	20.9	1	1	27.6	21.8
P6SMBJ18	LS	BS	18	20	25.3	1	1	32.2	18.6
P6SMBJ18A	LT	BT	18	20	22.1	1	1	29.2	20.6
P6SMBJ20	LU	BU	20	22.2	28.1	1	1	35.8	16.7
P6SMBJ20A	LV	BV	20	22.2	24.5	1	1	32.4	18.6
P6SMBJ22	LW	BW	22	24.4	30.9	1	1	39.4	15.2
P6SMBJ22A	LX	BX	22	24.4	26.9	1	1	35.5	16.9
P6SMBJ24	LY	BY	24	26.7	33.8	1	1	43	14
P6SMBJ24A	LZ	BZ	24	26.7	29.5	1	1	38.9	15.5
P6SMBJ26	MD	CD	26	28.9	36.8	1	1	46.6	12.4
P6SMBJ26A	ME	CE	26	28.9	31.9	1	1	42.1	14.3
P6SMBJ28	MF	CF	28	31.1	39.4	1	1	50	12
P6SMBJ28A	MG	CG	28	31.1	34.4	1	1	45.4	13.3
P6SMBJ30	MH	CH	30	33.3	42.4	1	1	53.5	11.2
P6SMBJ30A	MK	CK	30	33.3	36.8	1	1	48.4	12.4
P6SMBJ33	ML	CL	33	36.7	46.9	1	1	59	10.2
P6SMBJ33A	MM	CM	33	36.7	40.6	1	1	53.3	11.3
P6SMBJ36	MN	CN	36	40	50.7	1	1	64.3	9.3
P6SMBJ36A	MP	CP	36	40	44.2	1	1	58.1	10.4
P6SMBJ40	MQ	CQ	40	44.4	56.3	1	1	71.4	8.4
P6SMBJ40A	MR	CR	40	44.4	49.1	1	1	64.5	9.3

* = Add "C" or "CA" suffix for bidirectional device types.

+ = For Bidirectional Types Having V_{WM} <= 10V, their I_D limit is doubled.

= See General Information for Impulse Current Waveform.

P6SMBJ Series – 600 Watt Surface Mount (continued)**Electrical Characteristics (continued)**

Part Number*	Uni Part Marking	Bi Part Marking	Rated Standoff Voltage V _{wm}	Breakdown Voltage			Maximum Stand By Current @V _{WM} + I _d	10/1000 μ s Maximum Clamping Voltage @I _{ppm} # V _c Max	10/1000 μ s Rated Peak Impulse Current I _{ppm} #
				V _{br} (Volts)		@I _t			
				(Volts)	Min	Max			
P6SMBJ43	MS	CS	43	47.8	60.5	1	1	76.7	7.8
P6SMBJ43A	MT	CT	43	47.8	52.8	1	1	69.4	8.7
P6SMBJ45	MU	CU	45	50	63.3	1	1	80.3	7.5
P6SMBJ45A	MV	CV	45	50	55.3	1	1	72.7	8.3
P6SMBJ48	MW	CW	48	53.3	67.5	1	1	85.5	7
P6SMBJ48A	MX	CX	48	53.3	58.9	1	1	77.4	7.8
P6SMBJ51	MY	CY	51	56.7	71.8	1	1	91.1	6.6
P6SMBJ51A	MZ	CZ	51	56.7	62.7	1	1	82.4	7.3
P6SMBJ54	ND	DD	54	60	76	1	1	96.3	6.2
P6SMBJ54A	NE	DE	54	60	66.3	1	1	87.1	6.9
P6SMBJ58	NF	DF	58	64.4	81.6	1	1	103	5.8
P6SMBJ58A	NG	DG	58	64.4	71.2	1	1	93.6	6.5
P6SMBJ60	NH	DH	60	66.7	84.5	1	1	107	5.6
P6SMBJ60A	NK	DK	60	66.7	73.7	1	1	96.8	6.2
P6SMBJ64	NL	DL	64	71.1	90.1	1	1	114	5.3
P6SMBJ64A	NM	DM	64	71.1	78.6	1	1	103	5.9
P6SMBJ70	NN	DN	70	77.8	98.6	1	1	125	4.8
P6SMBJ70A	NP	DP	70	77.8	86.0	1	1	113	5.3
P6SMBJ75	NQ	DQ	75	83.3	106	1	1	134	4.5
P6SMBJ75A	NR	DR	75	83.3	92.1	1	1	121	5.0
P6SMBJ78	NS	DS	78	86.7	110	1	1	139	4.3
P6SMBJ78A	NT	DT	78	86.7	95.8	1	1	126	4.8
P6SMBJ85	NU	DU	85	94.4	119.2	1	1	151	3.9
P6SMBJ85A	NV	DV	85	94.4	104.0	1	1	137	4.4
P6SMBJ90	NW	DW	90	100	126.5	1	1	160	3.8
P6SMBJ90A	NX	DX	90	100	111.0	1	1	146	4.1

* = Add "C" or "CA" suffix for bidirectional device types.

+ = For Bidirectional Types Having V_{WM} <= 10V, their I_D limit is doubled.

= See General Information for Impulse Current Waveform.

P6SMBJ Series – 600 Watt Surface Mount (continued)**Electrical Characteristics (continued)**

Part Number*	Uni Part Marking	Bi Part Marking	Rated Standoff Voltage V _{wm}	Breakdown Voltage			Maximum Stand By Current @V _{WM} + I _d	10/1000 μ s Maximum Clamping Voltage @I _{ppm} # V _c Max	10/1000 μ s Rated Peak Impulse Current I _{ppm} #
				V _{br} (Volts)		@I _t			
				(Volts)	Min	Max			
P6SMBJ100	NY	DY	100	111	141	1	1	179	3.4
P6SMBJ100A	NZ	DZ	100	111	123	1	1	162	3.7
P6SMBJ110	PD	ED	110	122	154	1	1	196	3
P6SMBJ110A	PE	EE	110	122	135	1	1	177	3.4
P6SMBJ120	PF	EF	120	133	169	1	1	214	2.8
P6SMBJ120A	PG	EG	120	133	147	1	1	193	3.1
P6SMBJ130	PH	EH	130	144	182	1	1	231	2.6
P6SMBJ130A	PK	EK	130	144	159	1	1	209	2.9
P6SMBJ150	PL	EL	150	167	211.5	1	1	268	2.2
P6SMBJ150A	PM	EM	150	167	185	1	1	243	2.5
P6SMBJ160	PN	EN	160	178	226	1	1	287	2.1
P6SMBJ160A	PP	EP	160	178	197	1	1	259	2.3
P6SMBJ170	PQ	EQ	170	189	239.5	1	1	304	2
P6SMBJ170A	PR	ER	170	189	209	1	1	275	2.2
P6SMBJ180A	PT	ET	180	201	222	1	1	292	2.1
P6SMBJ190A	PA	EC	190	209	233	1	1	308	2
P6SMBJ200A	PV	EV	200	224	247	1	1	324	1.9
P6SMBJ210A	PB	ED	210	237	263	1	1	340	1.8
P6SMBJ220A	PX	EX	220	246	272	1	1	356	1.7
P6SMBJ250A	PZ	EZ	250	279	309	1	1	405	1.5
P6SMBJ300A	QE	FE	300	335	371	1	1	486	1.3
P6SMBJ350A	QG	FG	350	391	432	1	1	567	1.1
P6SMBJ400A	QK	FK	400	447	494	1	1	648	0.9
P6SMBJ440A	QM	FM	440	492	543	1	1	713	0.9

* = Add "C" or "CA" suffix for bidirectional device types.

+ = For Bidirectional Types Having V_{WM} <= 10V, their I_D limit is doubled.

= See General Information for Impulse Current Waveform.



1.5SMCJ Series – 1500 Watt Surface Mount



1.5SMCJ Series Features

- RoHS Compliance Standard
- 1500 watt peak pulse power dissipation
- Available in voltages from 5.0V to 440V
- Unidirectional and bidirectional
- Glass passivated junction
- Low clamping factor
- Available in tape and reel (Reel quantity = 3,000 pieces)
- Each device 100% surge tested
- UL 497B Recognized, File # E135015
- Tape and Reel to EIA Standard RS-481-A
- Gull-wing lead frame may be available upon request
- AEC-Q101 Qualified (8.0A & 8.0CA – 440A & 440CA) types. (When ordering ADD suffix “Z” to end of part number.)

Absolute Maximum Ratings

Parameter	Value
Peak pulse power dissipation (PPPM) at 25°C	1500W
Operating and storage temperatures	-55°C to + 150°C

Mechanical Characteristics

- DO214AB package
- UL94V-0 Thermoset Epoxy
- Solder plated terminals
- Solderable per MIL-STD-750 Method 2026

Mechanical Dimensions

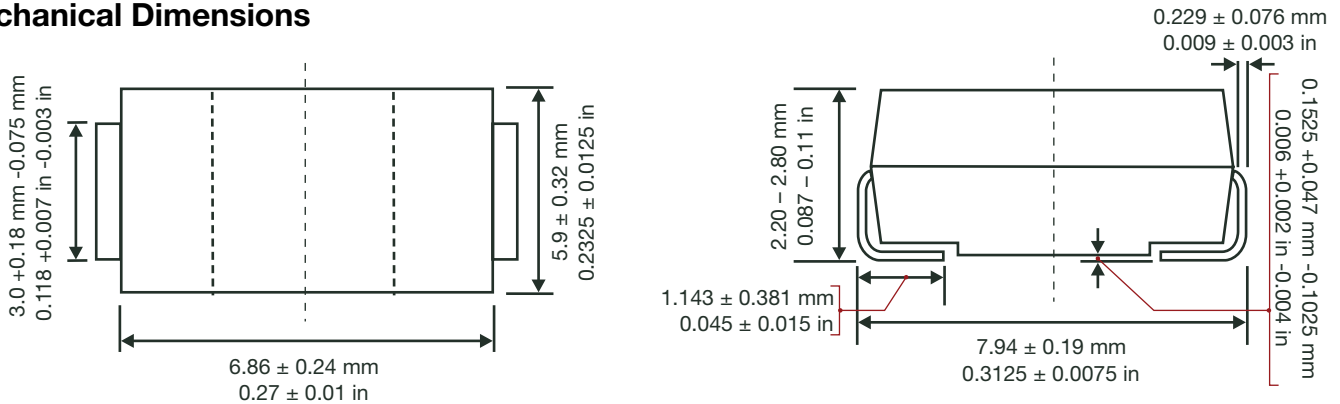

Standard Mounting Pad Layout

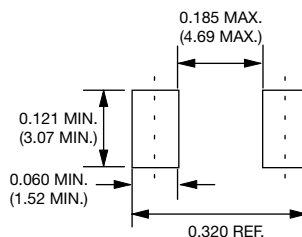

All dimensions in inches and (millimeters)

1.5SMCJ Series – 1500 Watt Surface Mount (continued)**Electrical Characteristics**

Part Number*	Uni Part Marking	Bi Part Marking	Rated Standoff Voltage V _{wm}	Breakdown Voltage			Maximum Stand By Current @V _{WM} + I _d	10/1000 μ s Maximum Clamping Voltage @I _{ppm} # V _c Max	10/1000 μ s Rated Peak Impulse Current I _{ppm} #
				V _{br} (Volts)		@I _t			
				(Volts)	Min	Max			
1.5SMCJ5.0	GDD	BDD	5	6.4	7.55	10	800	9.6	156.2
1.5SMCJ5.0A	GDE	BDE	5	6.4	7.00	10	800	9.2	163
1.5SMCJ6.0	GDF	BDF	6	6.67	8.45	10	800	11.4	131.6
1.5SMCJ6.0A	GDG	BDG	6	6.67	7.37	10	800	10.3	145.7
1.5SMCJ6.5	GDH	BDH	6.5	7.22	9.14	10	500	12.3	122
1.5SMCJ6.5A	GDK	BDK	6.5	7.22	7.98	10	500	11.2	134
1.5SMCJ7.0	GDL	BDL	7	7.78	9.86	10	200	13.3	112.8
1.5SMCJ7.0A	GDM	BDM	7	7.78	8.6	10	200	12	125
1.5SMCJ7.5	GDN	BDN	7.5	8.33	10.8	1	100	14.3	104.9
1.5SMCJ7.5A	GDP	BDP	7.5	8.33	9.21	1	100	12.9	116.3
1.5SMCJ8.0	GDQ	BDQ	8	8.89	11.3	1	50	15	100
1.5SMCJ8.0A	GDR	BDR	8	8.89	9.83	1	50	13.6	110.3
1.5SMCJ8.5	GDS	BDS	8.5	9.44	11.9	1	20	15.9	94.3
1.5SMCJ8.5A	GDT	BDT	8.5	9.44	10.4	1	20	14.4	104.2
1.5SMCJ9.0	GDU	BDU	9	10	12.8	1	10	16.9	88.7
1.5SMCJ9.0A	GDV	BDV	9	10	11.1	1	10	15.4	97.4
1.5SMCJ10	GDW	BDW	10	11.1	14.1	1	5	18.8	79.8
1.5SMCJ10A	GDX	BDX	10	11.1	12.3	1	5	17	88.3
1.5SMCJ11	GDY	BDY	11	12.2	15.4	1	1	20.1	74.6
1.5SMCJ11A	GDZ	BDZ	11	12.2	13.5	1	1	18.2	82.5
1.5SMCJ12	GED	BED	12	13.3	16.9	1	1	22	68.2
1.5SMCJ12A	GEE	BEE	12	13.3	14.7	1	1	19.9	75.4
1.5SMCJ13	GEF	BEF	13	14.4	18.2	1	1	23.8	63
1.5SMCJ13A	GEG	BEG	13	14.4	15.9	1	1	21.5	69.8
1.5SMCJ14	GEH	BEH	14	15.6	19.8	1	1	25.8	58.1
1.5SMCJ14A	GEK	BEK	14	15.6	17.2	1	1	23.2	64.7

* = Add "C" or "CA" suffix for bidirectional device types.

+ = For Bidirectional Types Having V_{WM} <= 10V, their I_D limit is doubled.

= See General Information for Impulse Current Waveform.

1.5SMCJ Series – 1500 Watt Surface Mount (continued)**Electrical Characteristics (continued)**

Part Number*	Uni Part Marking	Bi Part Marking	Rated Standoff Voltage V _{wm}	Breakdown Voltage			Maximum Stand By Current @V _{WM} + I _d	10/1000 μ s Maximum Clamping Voltage @I _{ppm} # V _c Max	10/1000 μ s Rated Peak Impulse Current I _{ppm} #
				V _{br} (Volts)		@I _t			
				(Volts)	Min	Max			
1.5SMCJ15	GEL	BEL	15	16.7	21.1	1	1	26.9	55.8
1.5SMCJ15A	GEM	BEM	15	16.7	18.5	1	1	24.4	61.5
1.5SMCJ16	GEN	BEN	16	17.8	22.6	1	1	28.8	52.1
1.5SMCJ16A	GEP	BEP	16	17.8	19.7	1	1	26	57.7
1.5SMCJ17	GEQ	BEQ	17	18.9	23.9	1	1	30.5	49.2
1.5SMCJ17A	GER	BER	17	18.9	20.9	1	1	27.6	54.4
1.5SMCJ18	GES	BES	18	20	25.3	1	1	32.2	46.6
1.5SMCJ18A	GET	BET	18	20	22.1	1	1	29.2	51.4
1.5SMCJ20	GEU	BEU	20	22.2	28.1	1	1	35.8	41.9
1.5SMCJ20A	GEV	BEV	20	22.2	24.5	1	1	32.4	46.3
1.5SMCJ22	GEW	BEW	22	24.4	30.9	1	1	39.4	38.1
1.5SMCJ22A	GEX	BEX	22	24.4	26.9	1	1	35.5	42.3
1.5SMCJ24	GEY	BEY	24	26.7	33.8	1	1	43	34.9
1.5SMCJ24A	GEZ	BEZ	24	26.7	29.5	1	1	38.9	38.6
1.5SMCJ26	GFD	BFD	26	28.9	36.8	1	1	46.6	32.2
1.5SMCJ26A	GFE	BFE	26	28.9	31.9	1	1	42.1	35.7
1.5SMCJ28	GFF	BFF	28	31.1	39.4	1	1	50	30
1.5SMCJ28A	GFG	BFG	28	31.1	34.4	1	1	45.4	33.1
1.5SMCJ30	GFH	BFH	30	33.3	42.4	1	1	53.5	28
1.5SMCJ30A	GFK	BFK	30	33.3	36.8	1	1	48.4	31
1.5SMCJ33	GFL	BFL	33	36.7	46.9	1	1	59	25.2
1.5SMCJ33A	GFM	BFM	33	36.7	40.6	1	1	53.3	28.2
1.5SMCJ36	GFN	BFN	36	40	50.7	1	1	64.3	23.3
1.5SMCJ36A	GFP	BFP	36	40	44.2	1	1	58.1	25.9
1.5SMCJ40	GFQ	BFQ	40	44.4	56.3	1	1	71.4	21
1.5SMCJ40A	GFR	BFR	40	44.4	49.1	1	1	64.5	23.3

* = Add "C" or "CA" suffix for bidirectional device types.

+ = For Bidirectional Types Having V_{WM} <= 10V, their I_D limit is doubled.

= See General Information for Impulse Current Waveform.

1.5SMCJ Series – 1500 Watt Surface Mount (continued)**Electrical Characteristics (continued)**

Part Number*	Uni Part Marking	Bi Part Marking	Rated Standoff Voltage V _{wm}	Breakdown Voltage			Maximum Stand By Current @V _{WM} + I _d	10/1000 μ s Maximum Clamping Voltage @I _{ppm} # V _c Max	10/1000 μ s Rated Peak Impulse Current I _{ppm} #
				V _{br} (Volts)		@I _t			
				(Volts)	Min	Max			
1.5SMCJ43	GFS	BFS	43	47.8	60.5	1	1	76.7	19.6
1.5SMCJ43A	GFT	BFT	43	47.8	52.8	1	1	69.4	21.7
1.5SMCJ45	GFU	BFU	45	50	63.3	1	1	80.3	18.7
1.5SMCJ45A	GFV	BFV	45	50	55.3	1	1	72.7	20.6
1.5SMCJ48	GFW	BFW	48	53.3	67.5	1	1	85.5	17.5
1.5SMCJ48A	GFX	BFX	48	53.3	58.9	1	1	77.4	19.4
1.5SMCJ51	GFY	BFY	51	56.7	71.8	1	1	91.1	18.5
1.5SMCJ51A	GFZ	BFZ	51	56.7	62.7	1	1	82.4	18.2
1.5SMCJ54	GGD	BGD	54	60	76	1	1	96.3	15.6
1.5SMCJ54A	GGE	BGE	54	60	66.3	1	1	87.1	17.3
1.5SMCJ58	GGF	BGF	58	64.4	81.6	1	1	103	14.6
1.5SMCJ58A	GGG	BGG	58	64.4	71.2	1	1	93.6	16.1
1.5SMCJ60	GGH	BGH	60	66.7	84.5	1	1	107	14
1.5SMCJ60A	GGK	BGK	60	66.7	73.7	1	1	96.8	15.5
1.5SMCJ64	GGL	BGL	64	71.1	90.1	1	1	114	13.2
1.5SMCJ64A	GGM	BGM	64	71.1	78.6	1	1	103	14.6
1.5SMCJ70	GGN	BGN	70	77.8	98.6	1	1	125	12
1.5SMCJ70A	GGP	BGP	70	77.8	86	1	1	113	13.3
1.5SMCJ75	GGQ	BGQ	75	83.3	106	1	1	134	11.2
1.5SMCJ75A	GGR	BGR	75	83.3	92.1	1	1	121	12.4
1.5SMCJ78	GGS	BGS	78	86.7	110	1	1	139	10.8
1.5SMCJ78A	GGT	BGT	78	86.7	95.8	1	1	126	11.9
1.5SMCJ85	GGU	BGU	85	94.4	119.2	1	1	151	9.9
1.5SMCJ85A	GGV	BGV	85	94.4	104	1	1	137	11
1.5SMCJ90	GGW	BGW	90	100	126.5	1	1	160	9.4
1.5SMCJ90A	GGX	BGX	90	100	111	1	1	146	10.3

* = Add "C" or "CA" suffix for bidirectional device types.

+ = For Bidirectional Types Having V_{WM} <= 10V, their I_D limit is doubled.

= See General Information for Impulse Current Waveform.

1.5SMCJ Series – 1500 Watt Surface Mount (continued)**Electrical Characteristics (continued)**

Part Number*	Uni Part Marking	Bi Part Marking	Rated Standoff Voltage V _{wm}	Breakdown Voltage			Maximum Stand By Current @V _{WM} + I _d	10/1000 μ s Maximum Clamping Voltage @I _{ppm} # V _c Max	10/1000 μ s Rated Peak Impulse Current I _{ppm} #
				V _{br} (Volts)		@I _t			
				(Volts)	Min	Max			
1.5SMCJ100	GGY	BGY	100	111	141	1	1	179	8.4
1.5SMCJ100A	GGZ	BGZ	100	111	123	1	1	162	9.3
1.5SMCJ110	GHD	BHD	110	122	154	1	1	196	7.7
1.5SMCJ110A	GHE	BHE	110	122	135	1	1	177	8.5
1.5SMCJ120	GHF	BHF	120	133	169	1	1	214	7
1.5SMCJ120A	GHG	BHG	120	133	147	1	1	193	7.8
1.5SMCJ130	GHH	BHH	130	144	182	1	1	231	6.5
1.5SMCJ130A	GHK	BHK	130	144	159	1	1	209	7.2
1.5SMCJ150	GHL	BHL	150	167	211.5	1	1	268	5.6
1.5SMCJ150A	GHM	BHM	150	167	185	1	1	243	6.2
1.5SMCJ160	GHN	BHN	160	178	226	1	1	287	5.2
1.5SMCJ160A	GHP	BHP	160	178	197	1	1	259	5.8
1.5SMCJ170	GHQ	BHQ	170	189	239.5	1	1	304	4.9
1.5SMCJ170A	GHR	BHR	170	189	209	1	1	275	5.5
1.5SMCJ180A	GHT	BHT	180	201	222	1	1	292	5.1
1.5SMCJ190A	GHU	BHU	190	211	233	1	1	308	4.8
1.5SMCJ200A	GHV	BHV	200	224	247	1	1	324	4.6
1.5SMCJ210A	GHW	BHW	210	237	263	1	1	340	4.4
1.5SMCJ220A	GHX	BHX	220	246	272	1	1	356	4.2
1.5SMCJ250A	GHZ	BHZ	250	279	309	1	1	405	3.7
1.5SMCJ300A	GJE	BJE	300	335	371	1	1	486	3.1
1.5SMCJ350A	GJG	BJG	350	391	432	1	1	567	2.6
1.5SMCJ400A	GJK	BJK	400	447	494	1	1	648	2.3
1.5SMCJ440A	GJM	BJM	440	492	543	1	1	713	2.1

* = Add "C" or "CA" suffix for bidirectional device types.

+ = For Bidirectional Types Having V_{WM} <= 10V, their I_D limit is doubled.

= See General Information for Impulse Current Waveform.



3.0SMCJ Series – 3000 Watt Surface Mount



3.0SMCJ Series Features

- RoHS Compliance Standard
- 3000 watt peak pulse power dissipation
- Available in voltages from 5.0V to 220V
- Unidirectional and bidirectional
- Glass passivated junction
- Low clamping factor
- Available in tape and reel (Reel quantity = 3,000 pieces)
- Each device 100% surge tested
- UL 497B Recognized, File # E135015
- Tape and Reel to EIA Standard RS - 481 - A
- Gull-wing lead frame may be available upon request
- AEC-Q101 Qualified (8.0A & 8.0CA – 220A & 220CA) types. (When ordering ADD suffix “Z” to end of part number.)

Absolute Maximum Ratings

Parameter	Value
Peak pulse power dissipation (PPPM) at 25°C	3000W
Operating and storage temperatures	-55°C to + 150°C

Mechanical Characteristics

- DO214AB package
- UL94V-0 Thermoset Epoxy
- Solder plated terminals
- Solderable per MIL-STD-750 Method 2026

Mechanical Dimensions

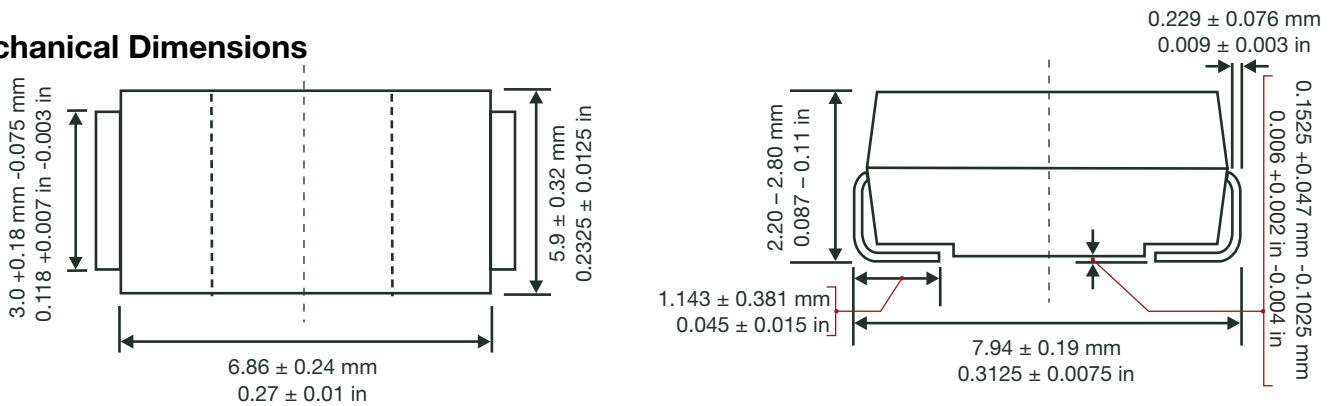

Standard Mounting Pad Layout

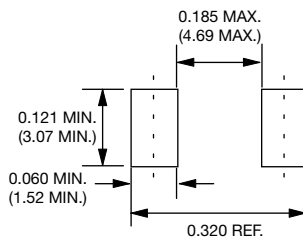

All dimensions in inches and (millimeters)

3.0SMCJ Series – 3000 Watt Surface Mount (continued)**Electrical Characteristics**

Part Number*	Uni Part Marking**	Bi Part Marking**	Rated Standoff Voltage V _{wm}	Breakdown Voltage			Maximum Stand By Current @V _{WM} + I _d	10/1000 μ s Maximum Clamping Voltage @I _{ppm} # V _c Max	10/1000 μ s Rated Peak Impulse Current I _{ppm} #
				V _{br} (Volts)		@I _t			
				(Volts)	Min	Max			
3.0SMCJ5.0	HDD	IDD	5	6.4	7.55	10	800	9.6	312.5
3.0SMCJ5.0A	HDE/RDE	IDE/DDE	5	6.4	7	10	800	9.2	326.1
3.0SMCJ6.0	HDF	IDF	6	6.67	8.45	10	800	11.4	263.2
3.0SMCJ6.0A	HDG/RDG	IDG/DDG	6	6.67	7.37	10	800	10.3	291.3
3.0SMCJ6.5	HDH	IDH	6.5	7.22	9.14	10	500	12.3	243.9
3.0SMCJ6.5A	HDK/RDK	IDK/DDK	6.5	7.22	7.98	10	500	11.2	267.9
3.0SMCJ7.0	HDL	IDL	7	7.78	9.86	10	200	13.3	225.6
3.0SMCJ7.0A	HDM/PDM	IDM/DDM	7	7.78	8.6	10	200	12	250
3.0SMCJ7.5	HDN	IDN	7.5	8.33	10.8	1	100	14.3	209.8
3.0SMCJ7.5A	HDP/PDP	IDP/DDP	7.5	8.33	9.21	1	100	12.9	232.6
3.0SMCJ8.0	HDQ	IDQ	8	8.89	11.3	1	50	15	200
3.0SMCJ8.0A	HDR/PDR	IDR/DDR	8	8.89	9.83	1	50	13.6	220.6
3.0SMCJ8.5	HDS	IDS	8.5	9.44	11.9	1	20	15.9	188.8
3.0SMCJ8.5A	HDT/PDT	IDT/DDT	8.5	9.44	10.4	1	20	14.4	208.3
3.0SMCJ9.0	HDU	IDU	9	10	12.8	1	10	16.9	177.4
3.0SMCJ9.0A	HDV/PDV	IDV/DDV	9	10	11.1	1	10	15.4	194.8
3.0SMCJ10	HDW	IDW	10	11.1	14.1	1	5	18.8	159.6
3.0SMCJ10A	HDX/PDX	IDX/DDX	10	11.1	13.3	1	5	17	176.5
3.0SMCJ11	HDY	IDY	11	12.2	15.4	1	2	20.1	149.2
3.0SMCJ11A	HDZ/PDZ	IDZ/DDZ	11	12.2	13.5	1	2	18.2	164.8
3.0SMCJ12	HED	IED	12	13.3	16.9	1	2	22	136.4
3.0SMCJ12A	HEE/PEE	IEE/DEE	12	13.3	14.7	1	2	19.9	150.8
3.0SMCJ13	HEF	IEF	13	14.4	18.2	1	2	23.8	126
3.0SMCJ13A	HEG/PEG	IEG/DEG	13	14.4	15.9	1	2	21.5	139.4
3.0SMCJ14	HEH	IEH	14	15.6	19.8	1	2	25.8	116.2
3.0SMCJ14A	HEK/PEK	IEK/DEK	14	15.6	17.2	1	2	23.2	129.3

* = Add "C" or "CA" suffix for bidirectional device types.

** = There may be two potential codes depending on factory designation.

+ = For Bidirectional Types Having V_{WM} <= 10V, their I_D limit is doubled.

= See General Information for Impulse Current Waveform.

3.0SMCJ Series – 3000 Watt Surface Mount (continued)**Electrical Characteristics (continued)**

Part Number*	Uni Part Marking**	Bi Part Marking**	Rated Standoff Voltage Vwm	Breakdown Voltage			Maximum Stand By Current @VWM+ Id	10/1000µs Maximum Clamping Voltage @Ippm# Vc Max	10/1000µs Rated Peak Impulse Current Ippm#
				Vbr (Volts)		@It			
				(Volts)	Min	Max			
3.0SMCJ15	HEL	IEL	15	16.7	21.1	1	2	26.9	111.6
3.0SMCJ15A	HEM/PEM	IEM/DEM	15	16.7	18.5	1	2	24.4	123
3.0SMCJ16	HEN	IEN	16	17.8	22.6	1	2	28.8	104.2
3.0SMCJ16A	HEP/PEP	IEP/DEP	16	17.8	19.7	1	2	26	115.4
3.0SMCJ17	HEQ	IEQ	17	18.9	23.9	1	2	30.5	98.4
3.0SMCJ17A	HER/PER	IER/DER	17	18.9	20.9	1	2	27.6	108.7
3.0SMCJ18	HES	IES	18	20.0	25.3	1	2	32.2	93.2
3.0SMCJ18A	HET/PET	IET/DET	18	20.0	22.1	1	2	29.2	102.7
3.0SMCJ20	HEU	IEU	20	22.2	28.1	1	2	35.8	83.8
3.0SMCJ20A	HEV/PEV	IEV/DEV	20	22.2	24.5	1	2	32.4	92.6
3.0SMCJ22	HEW	IEW	22	24.4	30.9	1	2	39.4	76.2
3.0SMCJ22A	HEX/PEX	IEX/DEX	22	24.4	26.9	1	2	35.5	84.5
3.0SMCJ24	HEY	IEY	24	26.7	33.8	1	2	43	69.8
3.0SMCJ24A	HEZ/PEZ	IEZ/DEZ	24	26.7	29.5	1	2	38.9	77.1
3.0SMCJ26	HFD	IFD	26	28.9	36.8	1	2	46.6	64.4
3.0SMCJ26A	HFE/PFE	IFE/DFE	26	28.9	31.9	1	2	42.1	71.3
3.0SMCJ28	HFF	IFF	28	31.1	39.4	1	2	50	60
3.0SMCJ28A	HFG/PFG	IFG/DFG	28	31.1	34.4	1	2	45.4	66.1
3.0SMCJ30	HFH	IFH	30	33.3	42.4	1	2	53.5	56
3.0SMCJ30A	HFJ/PFK	IFK/DFK	30	33.3	36.8	1	2	48.4	62
3.0SMCJ33	HFL	IFL	33	36.7	46.9	1	2	59	50.4
3.0SMCJ33A	HFM/PFM	IFM/DFM	33	36.7	40.6	1	2	53.3	56.3
3.0SMCJ36	HFN	IFN	36	40.0	50.7	1	2	64.3	46.6
3.0SMCJ36A	HFP/PFP	IFP/DFP	36	40.0	44.2	1	2	58.1	51.6
3.0SMCJ40	HFQ	IFQ	40	44.4	56.3	1	2	71.4	42
3.0SMCJ40A	HFR/PFR	IFR/DFR	40	44.4	49.1	1	2	64.5	46.5

* = Add "C" or "CA" suffix for bidirectional device types.

** = There may be two potential codes depending on factory designation.

+ = For Bidirectional Types Having VWM <= 10V, their ID limit is doubled.

= See General Information for Impulse Current Waveform.

3.0SMCJ Series – 3000 Watt Surface Mount (continued)**Electrical Characteristics (continued)**

Part Number*	Uni Part Marking**	Bi Part Marking**	Rated Standoff Voltage Vwm	Breakdown Voltage			Maximum Stand By Current @VWM+ Id	10/1000µs Maximum Clamping Voltage @Ippm# Vc Max	10/1000µs Rated Peak Impulse Current Ippm#
				Vbr (Volts)		@It			
				(Volts)	Min	Max			
3.0SMCJ43	HFS	IFS	43	47.8	60.5	1	2	76.7	39.2
3.0SMCJ43A	HFT/PFT	IFT/DFT	43	47.8	52.8	1	2	69.4	43.2
3.0SMCJ45	HFU	IFU	45	50	63.3	1	2	80.3	37.4
3.0SMCJ45A	HFV/PFV	IFV/DFV	45	50	55.3	1	2	72.7	41.3
3.0SMCJ48	HFV	IFV	48	53.3	67.5	1	2	85.5	35
3.0SMCJ48A	HFX/PFX	IFX/DFX	48	53.3	58.9	1	2	77.4	38.8
3.0SMCJ51	HFY	IFY	51	56.7	71.8	1	2	91.1	37
3.0SMCJ51A	HFZ/PFZ	IFZ/DFZ	51	56.7	62.7	1	2	82.4	36.4
3.0SMCJ54	HGD	IGD	54	60	76	1	2	96.3	31.2
3.0SMCJ54A	HGE/PGE	IGE/DGE	54	60	66.3	1	2	87.1	34.4
3.0SMCJ58	HGF	IGF	58	64.4	81.6	1	2	103	39.2
3.0SMCJ58A	HGG/PGG	IGG/DGG	58	64.4	71.2	1	2	93.6	32.1
3.0SMCJ60	HGH	IGH	60	66.7	84.5	1	2	107	28
3.0SMCJ60A	HGK/PGK	IGK/DGK	60	66.7	73.7	1	2	96.8	31
3.0SMCJ64	HGL	IGL	64	71.1	90.1	1	2	114	26.4
3.0SMCJ64A	HGM/PGM	IGM/DGM	64	71.1	78.6	1	2	103	29.1
3.0SMCJ70	HGN	IGN	70	77.8	98.6	1	2	125	24
3.0SMCJ70A	HGP/PGP	IGP/DGP	70	77.8	86	1	2	113	26.5
3.0SMCJ75	HGQ	IGQ	75	83.3	106	1	2	134	22.4
3.0SMCJ75A	HGR/PGR	IGR/DGR	75	83.3	92.1	1	2	121	24.8
3.0SMCJ78	HGS	IGS	78	86.7	110	1	2	139	21.6
3.0SMCJ78A	HGT/PGT	IGT/DGT	78	86.7	95.8	1	2	126	23.8
3.0SMCJ85	HGU	IGU	85	94.4	119.2	1	2	151	19.8
3.0SMCJ85A	HGV/PGV	IGV/DGV	85	94.4	104	1	2	137	21.9
3.0SMCJ90	HGW	IGW	90	100	126.5	1	2	160	18.8
3.0SMCJ90A	HGX/PGX	IGX/DGX	90	100	111	1	2	146	20.5

* = Add "C" or "CA" suffix for bidirectional device types.

** = There may be two potential codes depending on factory designation.

+ = For Bidirectional Types Having VWM <= 10V, their ID limit is doubled.

= See General Information for Impulse Current Waveform.

3.0SMCJ Series – 3000 Watt Surface Mount (continued)**Electrical Characteristics (continued)**

Part Number*	Uni Part Marking**	Bi Part Marking**	Rated Standoff Voltage Vwm	Breakdown Voltage			Maximum Stand By Current @VWM+ Id	10/1000µs Maximum Clamping Voltage @Ippm# Vc Max	10/1000µs Rated Peak Impulse Current Ippm#
				Vbr (Volts)		@It			
				(Volts)	Min	Max			
3.0SMCJ100	HGY	IGY	100	111	141	1	2	179	16.6
3.0SMCJ100A	HGZ/PGZ	IGZ/DGZ	100	111	123	1	2	162	18.5
3.0SMCJ110	HHD	IHD	110	122	154	1	2	196	15.4
3.0SMCJ110A	HHE/PHE	IHE/DHE	110	122	135	1	2	177	16.9
3.0SMCJ120	HHF	IHF	120	133	169	1	2	214	14
3.0SMCJ120A	HHG/PHG	IHG/DHG	120	133	147	1	2	193	15.5
3.0SMCJ130	HHH	IHH	130	144	182	1	2	231	13
3.0SMCJ130A	HHK/PHK	IHK/DHK	130	144	159	1	2	209	14.4
3.0SMCJ150	HHL	IHL	150	167	211.5	1	2	268	11.2
3.0SMCJ150A	HHM/PHM	IHM/DHM	150	167	185	1	2	243	12.3
3.0SMCJ160	HHN	IHN	160	178	226	1	2	287	10.4
3.0SMCJ160A	HHP/PHP	IHP/DHP	160	178	197	1	2	259	11.6
3.0SMCJ170	HHQ	IHQ	170	189	239.5	1	2	304	9.8
3.0SMCJ170A	HHR/PHR	IHR/DHR	170	189	209	1	2	275	10.9
3.0SMCJ180A	HHT	IHT	180	198	230.4	1	2	292	10.3
3.0SMCJ190A	HHV	IHV	190	211	233	1	2	308	9.7
3.0SMCJ200A	HHX	IHX	200	224	247	1	2	324	9.3
3.0SMCJ210A	HHZ	IHZ	210	237	263	1	2	340	8.8
3.0SMCJ220A	HIE	IIE	220	246	272	1	2	356	8.4

* = Add "C" or "CA" suffix for bidirectional device types.

** = There may be two potential codes depending on factory designation.

+ = For Bidirectional Types Having VWM <= 10V, their ID limit is doubled.

= See General Information for Impulse Current Waveform.



5.0SMCJ Series – 5000 Watt Surface Mount



5.0SMCJ Series Features

- RoHS Compliance Standard
- 5000 watt peak pulse power dissipation
- Available in voltages from 11V to 170V
- Unidirectional and Bidirectional
- Glass passivated junction
- Low clamping factor
- Available in tape and reel (Reel quantity = 3,000 pieces)
- Each device 100% surge tested
- UL 497B Recognized, File # E135015
- Tape and Reel to EIA Standard RS - 481 - A
- Gull-wing lead frame may be available upon request
- AEC-Q101 Qualified (22A & 22CA – 170A & 170CA) types. (When ordering ADD suffix “Z” to end of part number.)

Absolute Maximum Ratings

Parameter	Value
Peak pulse power dissipation (PPPM) at 25°C	5000W
Operating and storage temperatures	-55°C to + 150°C

Mechanical Characteristics

- DO214AB package
- UL94V-0 Thermoset Epoxy
- Solder plated terminals
- Solderable per MIL-STD-750 Method 2026

Mechanical Dimensions

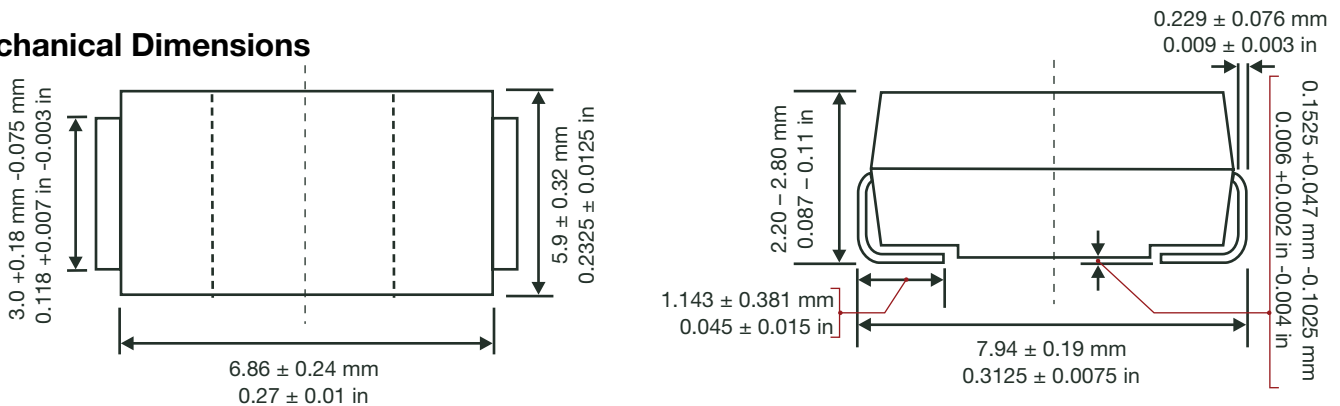

Standard Mounting Pad Layout

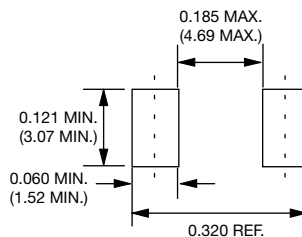

All dimensions in inches and (millimeters)

5.0SMCJ Series – 5000 Watt Surface Mount

Electrical Characteristics (continued)

Part Number*	Uni Part Marking**	Bi Part Marking**	Rated Standoff Voltage V _{wm}	Breakdown Voltage			Maximum Stand By Current @V _{WM} I _d	10/1000 μ s Maximum Clamping Voltage @I _{ppm} # V _c Max	10/1000 μ s Rated Peak Impulse Current I _{ppm} #
				V _{br} (Volts)		@I _t			
				(Volts)	Min	Max			
5.0SMCJ11A	5PEN	5BEN	11	12.2	13.5	10	800	18.2	275
5.0SMCJ12A	5PEP	5BEP	12	13.3	14.7	10	800	19.9	252
5.0SMCJ13A	5PEQ	5BEQ	13	14.4	15.9	10	500	21.5	233
5.0SMCJ14A	5PER	5BER	14	15.6	17.2	10	200	23.2	216
5.0SMCJ15A	5PES	5BES	15	16.7	18.5	1	100	24.4	205
5.0SMCJ16A	5PET	5BET	16	17.8	19.7	1	50	26.0	193
5.0SMCJ17A	5PEU	5BEU	17	18.9	20.9	1	20	27.6	181
5.0SMCJ18A	OET/5PEV	5BEV	18	20	22.1	1	10	29.2	172
5.0SMCJ20A	OEV/5PEW	5BEW	20	22.2	24.5	1	5	32.4	155
5.0SMCJ22A	OEX/5PEX	5BEX	22	24.4	26.9	1	5	35.5	141
5.0SMCJ24A	OEZ/5PEZ	5BEZ	24	26.7	29.5	1	2	38.9	129
5.0SMCJ26A	OFE/5PFE	5BFE	26	28.9	31.9	1	2	42.1	119
5.0SMCJ28A	OFG/5PFG	5BFG	28	31.1	34.4	1	2	45.4	110.0
5.0SMCJ30A	OFK/5PFK	5BFK	30	33.3	36.8	1	2	48.4	103.3
5.0SMCJ33A	OFM/5PFM	5BFM	33	36.7	40.6	1	2	53.3	93.8
5.0SMCJ36A	OFF/5PFP	5BFP	36	40	44.2	1	2	58.1	86.1
5.0SMCJ40A	5PFR	5BFR	40	44.4	49.1	1	2	64.5	77.6
5.0SMCJ43A	5PFT	5BFT	43	47.8	52.8	1	2	69.4	72.1
5.0SMCJ45A	5PFV	5BFV	45	50.0	55.3	1	2	72.7	68.8
5.0SMCJ48A	5PFX	5BFX	48	53.3	58.9	1	2	77.4	64.7
5.0SMCJ51A	5PFZ	5BFZ	51	56.7	62.7	1	2	82.4	60.7
5.0SMCJ54A	5PGE	5BGE	54	60.0	66.3	1	2	87.1	57.5
5.0SMCJ58A	5PGG	5BGG	58	64.4	71.2	1	2	93.6	53.5
5.0SMCJ60A	5PGK	5BGK	60	66.7	73.7	1	2	96.8	51.7
5.0SMCJ64A	5PGM	5BGM	64	71.1	78.6	1	2	103.0	48.6
5.0SMCJ70A	5PGP	5BGP	70	77.8	86.0	1	2	113.0	44.3
5.0SMCJ75A	5PGR	5BGR	75	83.3	92.1	1	2	121.0	41.4
5.0SMCJ78A	5PGT	5BGT	78	86.7	95.8	1	2	126.0	39.7
5.0SMCJ85A	5PGV	5BGV	85	94.4	104.0	1	2	137.0	36.5
5.0SMCJ90A	5PGX	5BGX	90	100.0	111.0	1	2	146.0	34.3
5.0SMCJ100A	5PGZ	5BGZ	100	111.0	123.0	1	2	162.0	30.9
5.0SMCJ110A	5PHE	5BHE	110	122.0	135.0	1	2	177.0	28.3
5.0SMCJ120A	5PHG	5BHG	120	133.0	147.0	1	2	193.0	26.0
5.0SMCJ130A	5PHK	5BHK	130	144.0	159.0	1	2	209.0	24.0
5.0SMCJ150A	5PHM	5BHM	150	167.0	185.0	1	2	243.0	20.6
5.0SMCJ160A	5PHP	5BHP	160	178.0	197.0	1	2	259.0	19.3
5.0SMCJ170A	5PHR	5BHR	170	189.0	209.0	1	2	275.0	18.2

* = Add "CA" suffix for bidirectional device types.

** = There may be two potential codes depending on factory designation.

+ = For Bidirectional Types Having V_{WM} <= 10V, their ID limit is doubled.

= See General Information for Impulse Current Waveform.

8SMEJ Series – 8000 Watt Surface Mount



8SMEJ Series Features

- RoHS Compliance Standard
- 8000 watt peak pulse power dissipation
- Available in voltages from 10V to 48V
- Unidirectional
- Glass passivated junction
- Low clamping factor
- Available in tape and reel (Reel quantity = 700 pieces)
- Meets MSL Level 1, per J-STD-020
- Tape and Reel to EIA Standard RS - 481 - A

Absolute Maximum Ratings and Characteristics

Rating	Symbol	Value	Units
Peak pulse power dissipation on 10/1000µs waveform	P_{PPM}	8000	W
Peak pulse current of on 10/1000µs waveform	I_{PPM}	See table	A
Operating junction and Storage Temperature range	T_J, T_{STG}	-55 to 150	°C

Dimensions

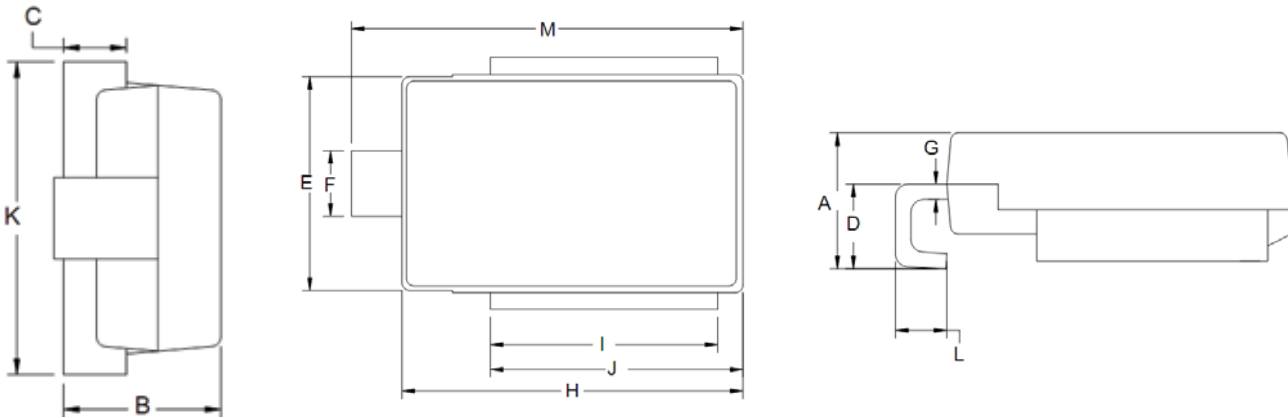

Symbol	Millimeters			Symbol	Millimeters		
	Min.	Nom.	Max.		Min.	Nom.	Max.
A	4.8	5.3	5.8	H	13.3	13.5	13.7
B	4.9	5.0	5.2	I	8.7	9.0	9.3
C	1.7	2.0	2.3	J	9.7	10.0	10.3
D	2.8	3.3	3.8	K	9.5	10.0	10.5
E	8.3	8.5	8.7	L	1.5	2.0	2.5
F	2.3	2.6	2.9	M	15.0	15.5	16.0
G	0.5	0.6	0.7				

8SMEJ Series – 8000 Watt Surface Mount

Electrical Characteristics

Part Number*	Standoff Voltage V_{RWM} (V)	Breakdown Voltage			Surge Discharge Current	Maximum Clamping Voltage	Reverse Leakage
		Vbr (Volts)		@It			
	(Volts)	Min.	Max.	(mA)	I_{PP} (A) @10/1000 μ s	V_C (V) @ I_{PP}	I_R (μ A) @ V_{DC}
8SMEJ10A	10	11.1	12.3	5	475.0	17.5	15
8SMEJ11A	11.0	12.2	13.5	5	443.8	18.7	15
8SMEJ12A	12.0	13.3	14.7	5	405.0	20.5	10
8SMEJ13A	13.0	14.4	15.9	5	373.8	22.1	10
8SMEJ14A	14.0	15.6	17.2	5	345.0	23.9	10
8SMEJ15A	15.0	16.7	18.5	5	327.5	25.1	10
8SMEJ16A	16.0	17.8	19.7	5	307.5	26.8	10
8SMEJ17A	17.0	18.9	20.9	5	288.8	28.4	10
8SMEJ18A	18.0	20.0	22.1	5	272.5	30.1	10
8SMEJ20A	20.0	22.2	24.5	5	245.0	33.4	10
8SMEJ22A	22.0	24.4	26.9	5	222.5	36.6	10
8SMEJ24A	24.0	26.7	29.5	5	202.5	40.1	10
8SMEJ26A	26.0	28.9	31.9	5	186.3	43.4	10
8SMEJ28A	28.0	31.1	34.4	5	171.3	46.8	10
8SMEJ30A	30.0	33.3	36.8	5	160.0	50.1	10
8SMEJ33A	33.0	36.7	40.6	5	145.0	55.2	10
8SMEJ36A	36.0	40.0	44.2	5	132.5	60.4	10
8SMEJ40A	40.0	44.4	49.1	5	117.5	68.3	10
8SMEJ43A	43.0	47.8	52.8	5	108.9	73.8	10
8SMEJ48A	48.0	53.2	58.7	5	93.5	85.6	10

PA4SMAJ Series



PA4SMAJ Series Features

- RoHS Compliance Standard
- For surface mounted applications in order to optimize board space
- Low profile package
- Built-in strain relief
- Glass passivated junction
- Low inductance
- Excellent clamping capability
- Repetition Rate (duty cycle): 0.01%
- Fast response time: typically less than 1.0 ps from 0 Volts to VBR for unidirectional types
- Typical IR less than 1 μ A above 10V
- High Temperature soldering: 260°C/10 seconds at terminals
- UL497B Recognized, File #E135015
- Tape and Reel to EIA Standard RS - 481 - A (Reel Quantity = 5000 pieces)
- AEC-Q101 Qualified (9.1A & 9.1CA – 550A & 550CA) types. (When ordering ADD suffix “Z” to end of part number.)



SMAJ/DO-214AC

Absolute Maximum Ratings

Ratings at 25°C ambient temperature unless otherwise specified.

Rating	Symbol	Value	Units
Peak pulse power dissipation on 10/1000 μ s waveform. (Note1 & 2, Fig. 1)	P _{PPM}	Minimum 400	Watts
Peak Pulse Current on 10/1000 μ s waveform. (Note 1, Fig. 2)	I _{PPM}	See Table	Amps
Steady State Power Dissipation at TL = 75°C. Lead lengths .375 in. (9.5mm). (Note 2, Fig. 5)	P _{M(AV)}	3.3	Watts
Peak Forward Surge Current, 8.3ms Single Half Sine-Wave Superimposed on Rated Load (JEDEC Method). (Note 3, Fig. 6)	I _{FSM}	40	Amps
Operating junction and Storage Temperature Range.	T _J , T _{STG}	-65 to +150	°C

- Notes:**
1. Non-repetitive current pulse, per Fig. 3 and derated above TA= 25°C per Fig. 2.
 2. Mounted on 5.0mm x 5.0mm (0.03mm thick) Copper Pads to each terminal.
 3. 8.3ms single half sine-wave or equivalent square wave. Duty Cycle = 4 pulses per minute maximum.

Mechanical Characteristics

- Case: JEDEC DO214AC. Molded plastic over glass passivated junction
- Terminal: Solder plated, solderable per MIL-STD-750, Method 2026
- Polarity: Color band denoted positive end (cathode) except Bi-directional
- Standard Packaging: 12mm tape (EIA STD RS-481)
- Weight: 0.002 ounce, 0.061 grams

Devices for Bipolar Application

For bi-directional use CA suffix for types PA4SMAJ 6.8CA thru types PA4SMAJ 550CA, electrical characteristics apply in both directions.

Mechanical Dimensions

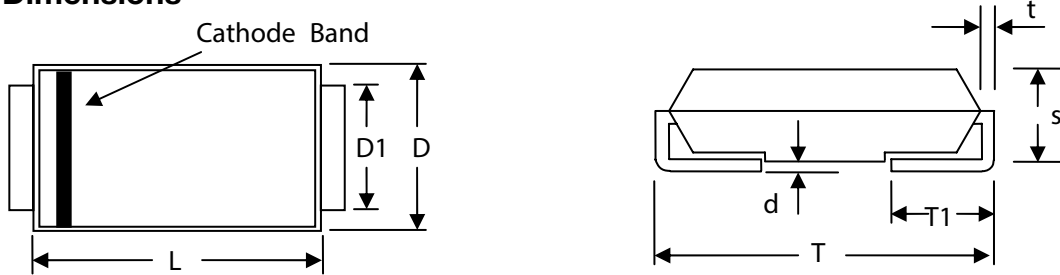

Item	Millimeters		Inches	
	Min.	Max.	Min.	Max.
L	3.99	4.50	0.157	0.177
D	2.54	2.79	0.100	0.110
D1	1.25	1.65	0.049	0.065
T	4.93	5.28	0.194	0.208
T1	0.76	1.52	0.030	0.060
d	---	0.203	---	0.008
s	2.00	2.50	0.079	0.098
t	0.152	0.305	0.006	0.012

Ratings and Characteristics Curves

(TA = 25°C unless otherwise noted)

Figure 1 - Peak Pulse Power Rating Curve

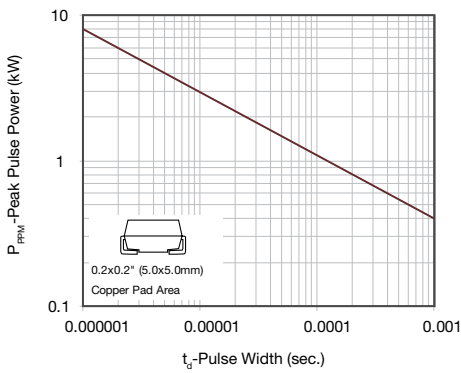

Figure 2 - Pulse Derating Curve

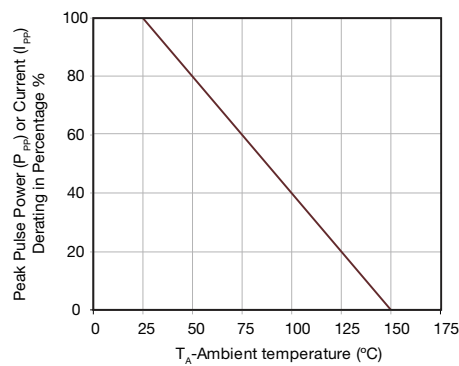

Figure 3 - Pulse Waveform

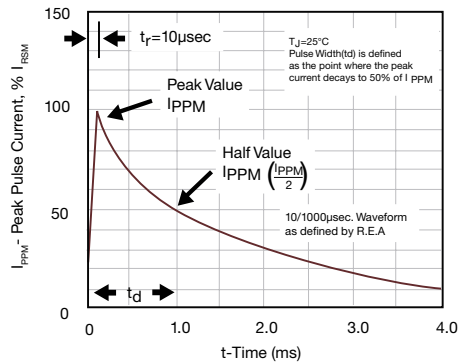

Figure 4 - Typical Junction Capacitance

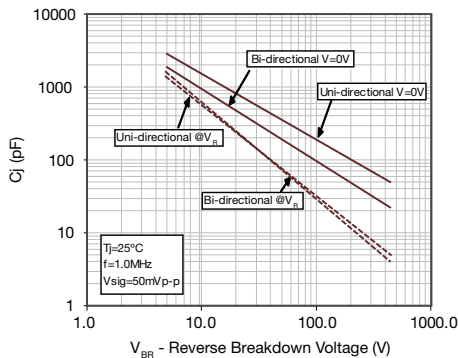

Figure 5 - Steady State Power Dissipation Derating Curve

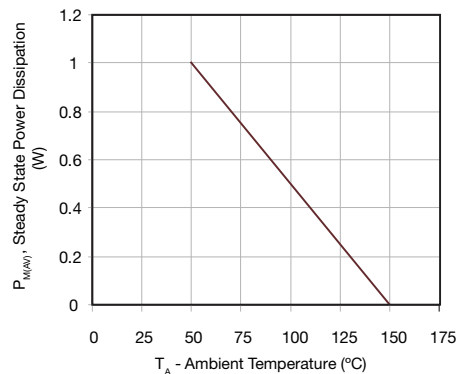
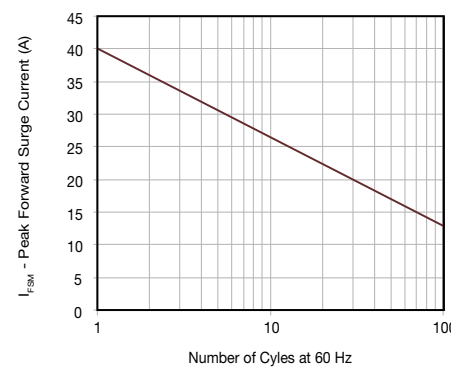

Figure 6 - Maximum Non-Repetitive Forward Surge Current Uni-Directional Only



PA4SMAJ Series

Electrical Characteristics

Part Number		Device Marking Code		Reverse Standoff Voltage	Breakdown Voltage @I _T		Test Current	Maximum Clamping Voltage @I _{PP}	Peak Pulse Current	Reverse Leakage @V _{RWM}
Uni Polar	Bi Polar	UNI	BI	V _{RWM} (V)	V _{BR} MIN. (V)	V _{BR} MAX. (V)	I _T (mA)	V _C (V)	I _{PP} (A)	I _R (μA)
PA4SMAJ6.8A	PA4SMAJ6.8CA	6V8A	6V8C	5.80	6.45	7.14	10	10.5	39.0	1000
PA4SMAJ7.5A	PA4SMAJ7.5CA	7V5A	7V5C	6.40	7.13	7.88	10	11.3	36.3	500
PA4SMAJ8.2A	PA4SMAJ8.2CA	8V2A	8V2C	7.02	7.79	8.61	10	12.1	33.9	200
PA4SMAJ9.1A	PA4SMAJ9.1CA	9V1A	9V1C	7.78	8.65	9.55	1	13.4	30.6	50
PA4SMAJ10A	PA4SMAJ10CA	10A	10C	8.55	9.50	10.50	1	14.5	28.3	10
PA4SMAJ11A	PA4SMAJ11CA	11A	11C	9.40	10.50	11.60	1	15.6	26.3	5
PA4SMAJ12A	PA4SMAJ12CA	12A	12C	10.20	11.40	12.60	1	16.7	24.6	5
PA4SMAJ13A	PA4SMAJ13CA	13A	13C	11.10	12.40	13.70	1	18.2	22.5	1
PA4SMAJ15A	PA4SMAJ15CA	15A	15C	12.80	14.30	15.80	1	21.2	19.3	1
PA4SMAJ16A	PA4SMAJ16CA	16A	16C	13.60	15.20	16.80	1	22.5	18.2	1
PA4SMAJ18A	PA4SMAJ18CA	18A	18C	15.30	17.10	18.90	1	25.5	16.1	1
PA4SMAJ20A	PA4SMAJ20CA	20A	20C	17.10	19.00	21.00	1	27.7	14.8	1
PA4SMAJ22A	PA4SMAJ22CA	22A	22C	18.80	20.90	23.10	1	30.6	13.4	1
PA4SMAJ24A	PA4SMAJ24CA	24A	24C	20.50	22.80	25.20	1	33.2	12.3	1
PA4SMAJ27A	PA4SMAJ27CA	27A	27C	23.10	25.70	28.40	1	37.5	10.9	1
PA4SMAJ30A	PA4SMAJ30CA	30A	30C	25.60	28.50	31.50	1	41.4	9.9	1
PA4SMAJ33A	PA4SMAJ33CA	33A	33C	28.20	31.40	34.70	1	45.7	9.0	1
PA4SMAJ36A	PA4SMAJ36CA	36A	36C	30.80	34.20	37.80	1	49.9	8.2	1
PA4SMAJ39A	PA4SMAJ39CA	39A	39C	33.30	37.10	41.00	1	53.9	7.6	1
PA4SMAJ43A	PA4SMAJ43CA	43A	43C	36.80	40.90	45.20	1	59.3	6.9	1
PA4SMAJ47A	PA4SMAJ47CA	47A	47C	40.20	44.70	49.40	1	64.8	6.3	1
PA4SMAJ51A	PA4SMAJ51CA	51A	51C	43.60	48.50	53.60	1	70.1	5.8	1
PA4SMAJ56A	PA4SMAJ56CA	56A	56C	47.80	53.20	58.80	1	77.0	5.3	1
PA4SMAJ62A	PA4SMAJ62CA	62A	62C	53.00	58.90	65.10	1	85.0	4.8	1
PA4SMAJ68A	PA4SMAJ68CA	68A	68C	58.10	64.60	71.40	1	92.0	4.5	1
PA4SMAJ75A	PA4SMAJ75CA	75A	75C	64.10	71.30	78.80	1	103.0	4.0	1
PA4SMAJ82A	PA4SMAJ82CA	82A	82C	70.10	77.90	86.10	1	113.0	3.6	1
PA4SMAJ91A	PA4SMAJ91CA	91A	91C	77.80	86.50	95.50	1	125.0	3.3	1

Note: For bi-directional type having V_{RWM} of 10 volts and less, the I_R limit is double.

PA4SMAJ Series

Electrical Characteristics (continued)

Part Number		Device Marking Code		Reverse Standoff Voltage	Breakdown Voltage @I _T		Test Current	Maximum Clamping Voltage @I _{PP}	Peak Pulse Current	Reverse Leakage @V _{RWM}
Uni Polar	Bi Polar	UNI	BI	V _{RWM} (V)	V _{BR} MIN. (V)	V _{BR} MAX. (V)	I _T (mA)	V _C (V)	I _{PP} (A)	I _R (μA)
PA4SMAJ100A	PA4SMAJ100CA	100A	100C	85.50	95.00	105.00	1	137.0	3.0	1
PA4SMAJ110A	PA4SMAJ110CA	110A	110C	94.00	105.00	116.00	1	152.0	2.7	1
PA4SMAJ120A	PA4SMAJ120CA	120A	120C	102.00	114.00	126.00	1	165.0	2.5	1
PA4SMAJ130A	PA4SMAJ130CA	130A	130C	111.00	124.00	137.00	1	179.0	2.3	1
PA4SMAJ150A	PA4SMAJ150CA	150A	150C	128.00	143.00	158.00	1	207.0	2.0	1
PA4SMAJ160A	PA4SMAJ160CA	160A	160C	136.00	152.00	168.00	1	219.0	1.9	1
PA4SMAJ170A	PA4SMAJ170CA	170A	170C	145.00	162.00	179.00	1	234.0	1.8	1
PA4SMAJ180A	PA4SMAJ180CA	180A	180C	154.00	171.00	189.00	1	246.0	1.7	1
PA4SMAJ200A	PA4SMAJ200CA	200A	200C	171.00	190.00	210.00	1	274.0	1.5	1
PA4SMAJ220A	PA4SMAJ220CA	220A	220C	185.00	209.00	231.00	1	328.0	1.3	1
PA4SMAJ250A	PA4SMAJ250CA	250A	250C	214.00	237.00	263.00	1	344.0	1.2	1
PA4SMAJ300A	PA4SMAJ300CA	300A	300C	256.00	285.00	315.00	1	414.0	1.0	1
PA4SMAJ350A	PA4SMAJ350CA	350A	350C	300.00	332.00	368.00	1	482.0	0.9	1
PA4SMAJ400A	PA4SMAJ400CA	400A	400C	342.00	380.00	420.00	1	548.0	0.8	1
PA4SMAJ440A	PA4SMAJ440CA	440A	440C	376.00	418.00	462.00	1	602.0	0.7	1
PA4SMAJ480A	PA4SMAJ480CA	480A	480C	408.00	456.00	504.00	1	658.0	0.6	1
PA4SMAJ510A	PA4SMAJ510CA	510A	510C	434.00	485.00	535.00	1	698.0	0.6	1
PA4SMAJ530A	PA4SMAJ530CA	530A	530C	450.00	503.50	556.50	1	725.0	0.6	1
PA4SMAJ540A	PA4SMAJ540CA	540A	540C	459.00	513.00	567.00	1	740.0	0.5	1
PA4SMAJ550A	PA4SMAJ550CA	550A	550C	467.00	522.50	577.50	1	760.0	0.5	1

Note: For bi-directional type having V_{RWM} of 10 volts and less, the I_R limit is double.

PA6SMBJ Series



PA6SMBJ Series Features

- RoHS Compliance Standard
- For surface mounted applications in order to optimize board space
- Low profile package
- Built-in strain relief
- Glass passivated junction
- Low inductance
- Excellent clamping capability
- Repetition Rate (duty cycle): 0.01%
- Fast response time: typically less than 1.0 ps from 0 Volts to VBR for unidirectional types
- Typical IR less than 1 μ A above 10V
- High Temperature soldering: 260°C/10 seconds at terminals
- UL497B Recognized, File #E135015
- Tape and Reel to EIA Standard RS - 481 - A (Reel Quantity = 3000 pieces)
- AEC-Q101 Qualified (9.1A & 9.1CA – 550A & 550CA) types. (When ordering ADD suffix “Z” to end of part number.)



SMBJ/DO-214AA

Absolute Maximum Ratings

Ratings at 25°C ambient temperature unless otherwise specified.

Rating	Symbol	Value	Units
Peak pulse power dissipation on 10/1000 μ s waveform. (Note1 & 2, Fig. 1)	P _{PPM}	Minimum 600	Watts
Peak Pulse Current on 10/1000 μ s waveform. (Note 1, Fig. 3)	I _{PPM}	See Table	Amps
Steady State Power Dissipation at TL = 75°C. Lead lengths .375 in. (9.5mm). (Note 2, Fig. 5)	P _{M(AV)}	5.0	Watts
Peak Forward Surge Current, 8.3ms Single Half Sine-Wave Superimposed on Rated Load (JEDEC Method). (Note 3, Fig. 6)	I _{FSM}	100	Amps
Operating junction and Storage Temperature Range.	T _J , T _{STG}	-65 to +150	°C

- Notes:**
1. Non-repetitive current pulse, per Fig. 3 and derated above TA= 25°C per Fig. 2.
 2. Mounted on 5.0mm x 5.0mm (0.03mm thick) Copper Pads to each terminal.
 3. 8.3ms single half sine-wave or equivalent square wave. Duty Cycle = 4 pulses per minute maximum.

Mechanical Characteristics

- Case: JEDEC DO214AA. Molded plastic over glass passivated junction
- Terminal: Solder plated, solderable per MIL-STD-750, Method 2026
- Polarity: Color band denoted positive end (cathode) except Bi-directional
- Standard Packaging: 12mm tape (EIA STD RS-481)
- Weight: 0.003 ounce, 0.093 grams

Devices for Bipolar Application

For bi-directional use CA suffix for types PA6SMBJ 6.8CA thru types PA6SMBJ 550 CA, electrical characteristics apply in both directions.

Mechanical Dimensions

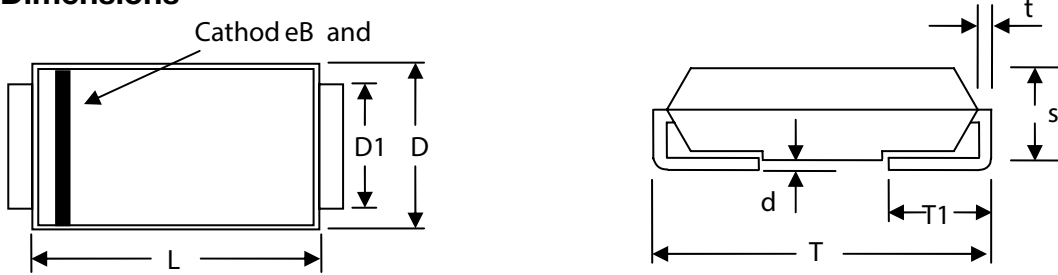

Item	Millimeters		Inches	
	Min.	Max.	Min.	Max.
L	4.06	4.57	0.160	0.180
D	3.30	3.94	0.130	0.155
D1	1.95	2.20	0.077	0.086
T	5.21	5.59	0.205	0.220
T1	0.76	1.52	0.030	0.060
d	---	0.203	---	0.008
s	2.15	2.65	0.085	0.104
t	0.152	0.305	0.006	0.012

Ratings and Characteristics Curves

(TA = 25°C unless otherwise noted)

Figure 1 - Peak Pulse Power Rating Curve

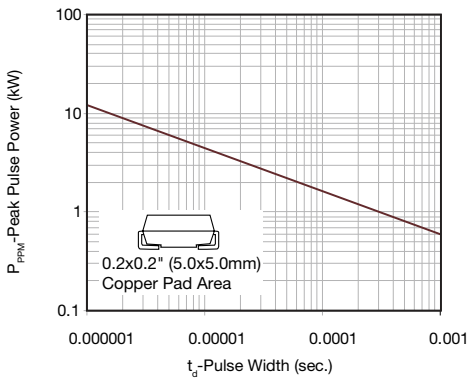

Figure 2 - Pulse Derating Curve

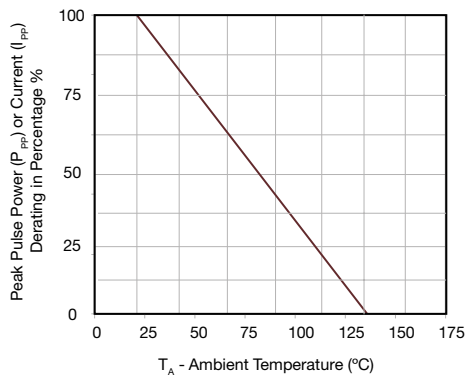

Figure 3 - Pulse Waveform

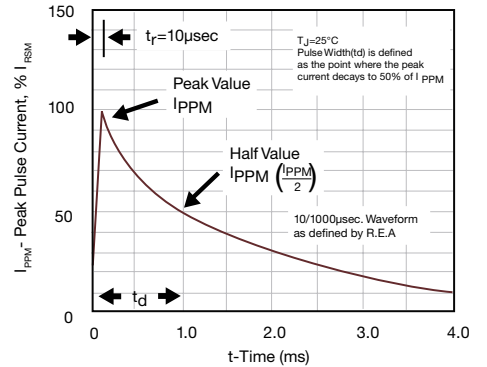

Figure 4 - Typical Junction Capacitance

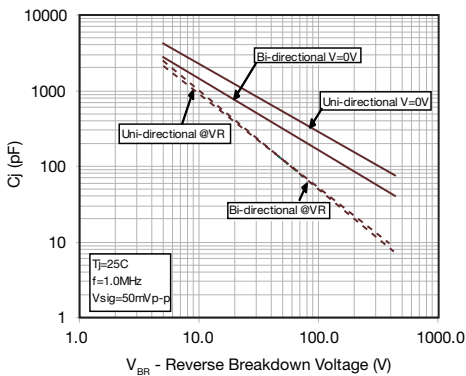

Figure 5 - Steady State Power Dissipation Derating Curve

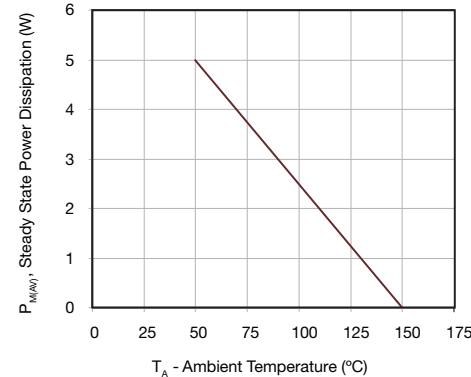
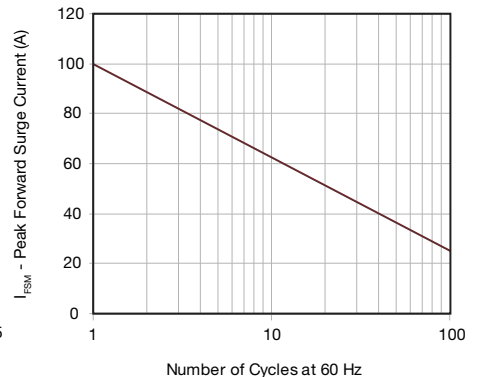

Figure 6 - Maximum Non-Repetitive Forward Surge Current Uni-Directional Only



PA6SMBJ Series

Electrical Characteristics

Part Number		Device Marking Code		Reverse Standoff Voltage	Breakdown Voltage @I _T		Test Current	Maximum Clamping Voltage @I _{PP}	Peak Pulse Current	Reverse Leakage @V _{RWM}
Uni Polar	Bi Polar	UNI	BI	V _{RWM} (V)	V _{BR} MIN. (V)	V _{BR} MAX. (V)	I _T (mA)	V _C (V)	I _{PP} (A)	I _R (μA)
PA6SMBJ6.8A	PA6SMBJ6.8CA	6V8A	6V8C	5.80	6.45	7.14	10	10.5	58.1	1000
PA6SMBJ7.5A	PA6SMBJ7.5CA	7V5A	7V5C	6.40	7.13	7.88	10	11.3	54.0	500
PA6SMBJ8.2A	PA6SMBJ8.2CA	8V2A	8V2C	7.02	7.79	8.61	10	12.1	50.4	200
PA6SMBJ9.1A	PA6SMBJ9.1CA	9V1A	9V1C	7.78	8.65	9.55	1	13.4	45.5	50
PA6SMBJ10A	PA6SMBJ10CA	10A	10C	8.55	9.50	10.50	1	14.5	42.1	10
PA6SMBJ11A	PA6SMBJ11CA	11A	11C	9.40	10.50	11.60	1	15.6	39.1	5
PA6SMBJ12A	PA6SMBJ12CA	12A	12C	10.20	11.40	12.60	1	16.7	36.5	5
PA6SMBJ13A	PA6SMBJ13CA	13A	13C	11.10	12.40	13.70	1	18.2	33.5	1
PA6SMBJ15A	PA6SMBJ15CA	15A	15C	12.80	14.30	15.80	1	21.2	28.8	1
PA6SMBJ16A	PA6SMBJ16CA	16A	16C	13.60	15.20	16.80	1	22.5	27.1	1
PA6SMBJ18A	PA6SMBJ18CA	18A	18C	15.30	17.10	18.90	1	25.5	24.2	1
PA6SMBJ20A	PA6SMBJ20CA	20A	20C	17.10	19.00	21.00	1	27.7	22.0	1
PA6SMBJ22A	PA6SMBJ22CA	22A	22C	18.80	20.90	23.10	1	30.6	19.9	1
PA6SMBJ24A	PA6SMBJ24CA	24A	24C	20.50	22.80	25.20	1	33.2	18.4	1
PA6SMBJ27A	PA6SMBJ27CA	27A	27C	23.10	25.70	28.40	1	37.5	16.3	1
PA6SMBJ30A	PA6SMBJ30CA	30A	30C	25.60	28.50	31.50	1	41.4	14.7	1
PA6SMBJ33A	PA6SMBJ33CA	33A	33C	28.20	31.40	34.70	1	45.7	13.3	1
PA6SMBJ36A	PA6SMBJ36CA	36A	36C	30.80	34.20	37.80	1	49.9	12.2	1
PA6SMBJ39A	PA6SMBJ39CA	39A	39C	33.30	37.10	41.00	1	53.9	11.3	1
PA6SMBJ43A	PA6SMBJ43CA	43A	43C	36.80	40.90	45.20	1	59.3	10.3	1
PA6SMBJ47A	PA6SMBJ47CA	47A	47C	40.20	44.70	49.40	1	64.8	9.4	1
PA6SMBJ51A	PA6SMBJ51CA	51A	51C	43.60	48.50	53.60	1	70.1	8.7	1
PA6SMBJ56A	PA6SMBJ56CA	56A	56C	47.80	53.20	58.80	1	77.0	7.9	1
PA6SMBJ62A	PA6SMBJ62CA	62A	62C	53.00	58.90	65.10	1	85.0	7.2	1
PA6SMBJ68A	PA6SMBJ68CA	68A	68C	58.10	64.60	71.40	1	92.0	6.6	1
PA6SMBJ75A	PA6SMBJ75CA	75A	75C	64.10	71.30	78.80	1	103.0	5.9	1
PA6SMBJ82A	PA6SMBJ82CA	82A	82C	70.10	77.90	86.10	1	113.0	5.4	1
PA6SMBJ91A	PA6SMBJ91CA	91A	91C	77.80	86.50	95.50	1	125.0	4.9	1

Note: For bi-directional type having V_{RWM} of 10 volts and less, the I_R limit is double.

PA6SMBJ Series

Electrical Characteristics (continued)

Part Number		Device Marking Code		Reverse Standoff Voltage	Breakdown Voltage @I _T		Test Current	Maximum Clamping Voltage @I _{PP}	Peak Pulse Current	Reverse Leakage @V _{RWM}
Uni Polar	Bi Polar	UNI	BI	V _{RWM} (V)	V _{BR} MIN. (V)	V _{BR} MAX. (V)	I _T (mA)	V _C (V)	I _{PP} (A)	I _R (μA)
PA6SMBJ100A	PA6SMBJ100CA	100A	100C	85.50	95.00	105.00	1	137.0	4.5	1
PA6SMBJ110A	PA6SMBJ110CA	110A	110C	94.00	105.00	116.00	1	152.0	4.0	1
PA6SMBJ120A	PA6SMBJ120CA	120A	120C	102.00	114.00	126.00	1	165.0	3.7	1
PA6SMBJ130A	PA6SMBJ130CA	130A	130C	111.00	124.00	137.00	1	179.0	3.4	1
PA6SMBJ150A	PA6SMBJ150CA	150A	150C	128.00	143.00	158.00	1	207.0	2.9	1
PA6SMBJ160A	PA6SMBJ160CA	160A	160C	136.00	152.00	168.00	1	219.0	2.8	1
PA6SMBJ170A	PA6SMBJ170CA	170A	170C	145.00	162.00	179.00	1	234.0	2.6	1
PA6SMBJ180A	PA6SMBJ180CA	180A	180C	154.00	171.00	189.00	1	246.0	2.5	1
PA6SMBJ200A	PA6SMBJ200CA	200A	200C	171.00	190.00	210.00	1	274.0	2.2	1
PA6SMBJ220A	PA6SMBJ220CA	220A	220C	185.00	209.00	231.00	1	328.0	1.9	1
PA6SMBJ250A	PA6SMBJ250CA	250A	250C	214.00	237.00	263.00	1	344.0	1.8	1
PA6SMBJ300A	PA6SMBJ300CA	300A	300C	256.00	285.00	315.00	1	414.0	1.5	1
PA6SMBJ350A	PA6SMBJ350CA	350A	350C	300.00	332.00	368.00	1	482.0	1.3	1
PA6SMBJ400A	PA6SMBJ400CA	400A	400C	342.00	380.00	420.00	1	548.0	1.1	1
PA6SMBJ440A	PA6SMBJ440CA	440A	440C	376.00	418.00	462.00	1	602.0	1.0	1
PA6SMBJ480A	PA6SMBJ480CA	480A	480C	408.00	456.00	504.00	1	658.0	0.9	1
PA6SMBJ510A	PA6SMBJ510CA	510A	510C	434.00	485.00	535.00	1	698.0	0.9	1
PA6SMBJ530A	PA6SMBJ530CA	530A	530C	450.00	503.50	556.50	1	725.0	0.8	1
PA6SMBJ540A	PA6SMBJ540CA	540A	540C	459.00	513.00	567.00	1	740.0	0.8	1
PA6SMBJ550A	PA6SMBJ550CA	550A	550C	467.00	522.50	577.50	1	760.0	0.8	1

Note: For bi-directional type having V_{RWM} of 10 volts and less, the I_R limit is double.

1.5ASMCJ Series



1.5ASMCJ Series Features

- RoHS Compliance Standard
- For surface mounted applications in order to optimize board space
- Low profile package
- Built-in strain relief
- Glass passivated junction
- Low inductance
- Excellent clamping capability
- Repetition Rate (duty cycle): 0.01%
- Fast response time: typically less than 1.0 ps from 0 Volts to BV min.
- Typical IR less than 1 μ A above 10V
- High Temperature soldering: 260°C/10 seconds at terminals
- UL497B Recognized, File #E135015
- Tape and Reel to EIA Standard RS - 481 - A (Reel Quantity = 3000 pieces)
- Gull-wing lead frame may be available upon request
- AEC-Q101 Qualified (9.1A & 9.1CA – 550A & 550CA) types. (When ordering ADD suffix “Z” to end of part number.)



SMCJ/DO-214AB

Absolute Maximum Ratings

Ratings at 25°C ambient temperature unless otherwise specified.

Rating	Symbol	Value	Units
Peak pulse power dissipation on 10/1000 μ s waveform. (Note1 & 2, Fig. 1)	P _{PPM}	Minimum 1500	Watts
Peak Pulse Current on 10/1000 μ s waveform. (Note 1, Fig. 3)	I _{PPM}	See Table	Amps
Steady State Power Dissipation at TL = 75°C. Lead lengths .375 in. (9.5mm). (Note 2, Fig. 5)	P _{M(AV)}	6.5	Watts
Peak Forward Surge Current, 8.3ms Single Half Sine-Wave Superimposed on Rated Load (JEDEC Method). (Note 3, Fig. 6)	I _{FSM}	200	Amps
Operating junction and Storage Temperature Range.	T _J , T _{STG}	-65 to +150	°C

- Notes:**
1. Non-repetitive current pulse, per Fig. 3 and derated above TA= 25°C per Fig. 2.
 2. Mounted on 5.0mm x 5.0mm (0.03mm thick) Copper Pads to each terminal.
 3. 8.3ms single half sine-wave or equivalent square wave. Duty Cycle = 4 pulses per minute maximum.

Mechanical Characteristics

- Case: JEDEC DO214AB. Molded plastic over glass passivated junction
- Terminal: Solder plated, solderable per MIL-STD-750, Method 2026
- Polarity: Color band denoted positive end (cathode) except Bi-directional
- Standard Packaging: 16mm tape (EIA STD RS-481)
- Weight: 0.007 ounce, 0.21 grams

Devices for Bipolar Application

For bi-directional use CA suffix for types 1.5ASMCJ 6.8CA thru types 1.5ASMCJ 550CA, electrical characteristics apply in both directions.

Mechanical Dimensions

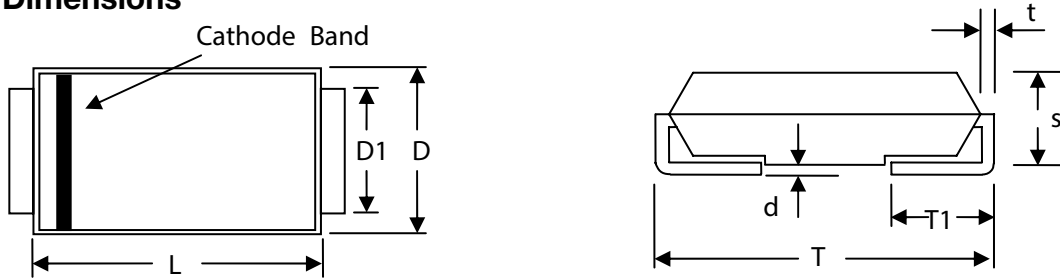

Item	Millimeters		Inches	
	Min.	Max.	Min.	Max.
L	6.60	7.11	0.260	0.280
D	5.59	6.22	0.220	0.245
D1	2.90	3.20	0.114	0.126
T	7.75	8.13	0.305	0.320
T1	0.76	1.52	0.030	0.060
d	---	0.203	---	0.008
s	2.20	2.80	0.087	0.110
t	0.152	0.305	0.006	0.012

Ratings and Characteristics Curves

(TA = 25°C unless otherwise noted)

Figure 1 - Peak Pulse Power Rating Curve

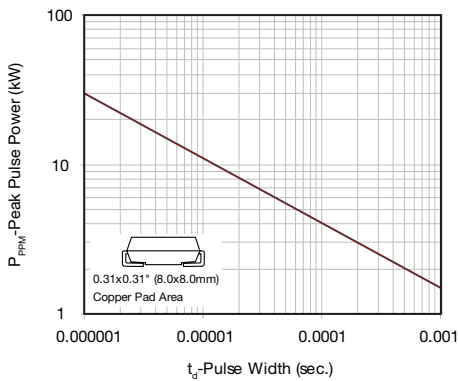

Figure 2 - Pulse Derating Curve

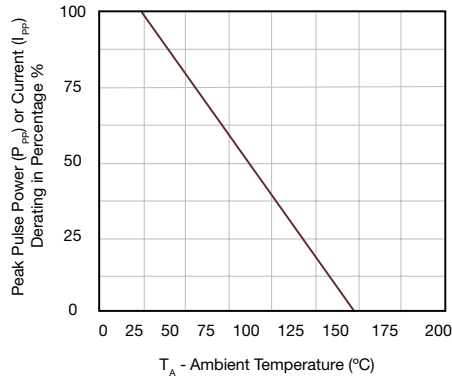

Figure 3 - Pulse Waveform

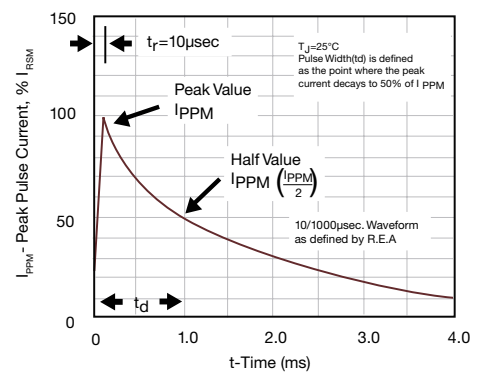

Figure 4 - Typical Junction Capacitance

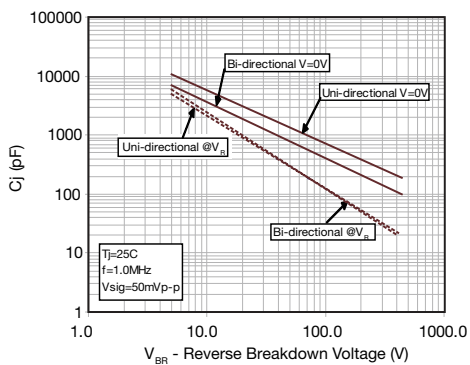

Figure 5 - Steady State Power Dissipation Derating Curve

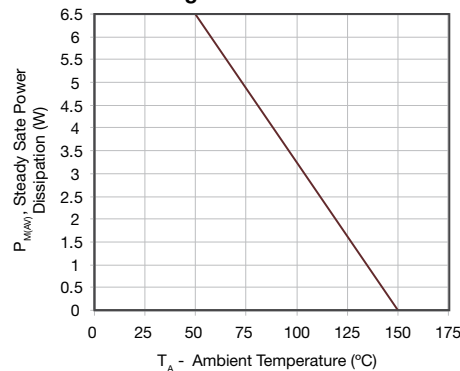
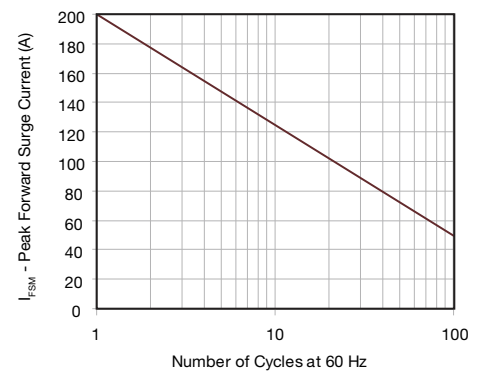

Figure 6 - Maximum Non-Repetitive Forward Surge Current Uni-Directional Only



1.5ASMCJ Series

Electrical Characteristics

Part Number		Device Marking Code		Reverse Standoff Voltage	Breakdown Voltage @I _T		Test Current	Maximum Clamping Voltage @I _{PP}	Peak Pulse Current	Reverse Leakage @V _{RWM}
Uni Polar	Bi Polar	UNI	BI	V _{RWM} (V)	V _{BR} MIN. (V)	V _{BR} MAX. (V)	I _T (mA)	V _C (V)	I _{PP} (A)	I _R (μA)
1.5ASMCJ6.8A	1.5ASMCJ6.8CA	6V8A	6V8C	5.80	6.45	7.14	10	10.5	144.8	1000
1.5ASMCJ7.5A	1.5ASMCJ7.5CA	7V5A	7V5C	6.40	7.13	7.88	10	11.3	134.5	500
1.5ASMCJ8.2A	1.5ASMCJ8.2CA	8V2A	8V2C	7.02	7.79	8.61	10	12.1	125.6	200
1.5ASMCJ9.1A	1.5ASMCJ9.1CA	9V1A	9V1C	7.78	8.65	9.50	1	13.4	113.4	50
1.5ASMCJ10A	1.5ASMCJ10CA	10A	10C	8.55	9.50	10.50	1	14.5	104.8	10
1.5ASMCJ11A	1.5ASMCJ11CA	11A	11C	9.40	10.50	11.60	1	15.6	97.4	5
1.5ASMCJ12A	1.5ASMCJ12CA	12A	12C	10.20	11.40	12.60	1	16.7	91.0	5
1.5ASMCJ13A	1.5ASMCJ13CA	13A	13C	11.10	12.40	13.70	1	18.2	83.5	1
1.5ASMCJ15A	1.5ASMCJ15CA	15A	15C	12.80	14.30	15.80	1	21.2	71.7	1
1.5ASMCJ16A	1.5ASMCJ16CA	16A	16C	13.60	15.20	16.80	1	22.5	67.6	1
1.5ASMCJ18A	1.5ASMCJ18CA	18A	18C	15.30	17.10	18.90	1	25.5	60.3	1
1.5ASMCJ20A	1.5ASMCJ20CA	20A	20C	17.10	19.00	21.00	1	27.7	54.9	1
1.5ASMCJ22A	1.5ASMCJ22CA	22A	22C	18.80	20.90	23.10	1	30.6	49.7	1
1.5ASMCJ24A	1.5ASMCJ24CA	24A	24C	20.50	22.80	25.20	1	33.2	45.8	1
1.5ASMCJ27A	1.5ASMCJ27CA	27A	27C	23.10	25.70	28.40	1	37.5	40.5	1
1.5ASMCJ30A	1.5ASMCJ30CA	30A	30C	25.60	28.50	31.50	1	41.4	36.7	1
1.5ASMCJ33A	1.5ASMCJ33CA	33A	33C	28.20	31.40	34.70	1	45.7	33.3	1
1.5ASMCJ36A	1.5ASMCJ36CA	36A	36C	30.80	34.20	37.80	1	49.9	30.5	1
1.5ASMCJ39A	1.5ASMCJ39CA	39A	39C	33.30	37.10	41.00	1	53.9	28.2	1
1.5ASMCJ43A	1.5ASMCJ43CA	43A	43C	36.80	40.90	45.20	1	59.3	25.6	1
1.5ASMCJ47A	1.5ASMCJ47CA	47A	47C	40.20	44.70	49.40	1	64.8	23.5	1
1.5ASMCJ51A	1.5ASMCJ51CA	51A	51C	43.60	48.50	53.60	1	70.1	21.7	1
1.5ASMCJ56A	1.5ASMCJ56CA	56A	56C	47.80	53.20	58.80	1	77.0	19.7	1
1.5ASMCJ62A	1.5ASMCJ62CA	62A	62C	53.00	58.90	65.10	1	85.0	17.9	1
1.5ASMCJ68A	1.5ASMCJ68CA	68A	68C	58.10	64.60	71.40	1	92.0	16.5	1
1.5ASMCJ75A	1.5ASMCJ75CA	75A	75C	64.10	71.30	78.80	1	103.0	14.8	1
1.5ASMCJ82A	1.5ASMCJ82CA	82A	82C	70.10	77.90	86.10	1	113.0	13.5	1
1.5ASMCJ91A	1.5ASMCJ91CA	91A	91C	77.80	86.50	95.50	1	125.0	12.2	1

Note: For bi-directional type having V_{RWM} of 10 volts and less, the I_R limit is double.

1.5ASMCJ Series**Electrical Characteristics (continued)**

Part Number		Device Marking Code		Reverse Standoff Voltage	Breakdown Voltage @I _T		Test Current	Maximum Clamping Voltage @I _{PP}	Peak Pulse Current	Reverse Leakage @V _{RWM}
Uni Polar	Bi Polar	UNI	BI	V _{RWM} (V)	V _{BR} MIN. (V)	V _{BR} MAX. (V)	I _T (mA)	V _C (V)	I _{PP} (A)	I _R (μA)
1.5ASMCJ100A	1.5ASMCJ100CA	100A	100C	85.50	95.00	105.00	1	137.0	11.1	1
1.5ASMCJ110A	1.5ASMCJ110CA	110A	110C	94.00	105.00	116.00	1	152.0	10.0	1
1.5ASMCJ120A	1.5ASMCJ120CA	120A	120C	102.00	114.00	126.00	1	165.0	9.2	1
1.5ASMCJ130A	1.5ASMCJ130CA	130A	130C	111.00	124.00	137.00	1	179.0	8.5	1
1.5ASMCJ150A	1.5ASMCJ150CA	150A	150C	128.00	143.00	158.00	1	207.0	7.3	1
1.5ASMCJ160A	1.5ASMCJ160CA	160A	160C	136.00	152.00	168.00	1	219.0	6.9	1
1.5ASMCJ170A	1.5ASMCJ170CA	170A	170C	145.00	162.00	179.00	1	234.0	6.5	1
1.5ASMCJ180A	1.5ASMCJ180CA	180A	180C	154.00	171.00	189.00	1	246.0	6.2	1
1.5ASMCJ200A	1.5ASMCJ200CA	200A	200C	171.00	190.00	210.00	1	274.0	5.5	1
1.5ASMCJ220A	1.5ASMCJ220CA	220A	220C	185.00	209.00	231.00	1	328.0	4.6	1
1.5ASMCJ250A	1.5ASMCJ250CA	250A	250C	214.00	237.00	263.00	1	344.0	4.4	1
1.5ASMCJ300A	1.5ASMCJ300CA	300A	300C	256.00	285.00	315.00	1	414.0	3.7	1
1.5ASMCJ350A	1.5ASMCJ350CA	350A	350C	300.00	332.00	368.00	1	482.0	3.2	1
1.5ASMCJ400A	1.5ASMCJ400CA	400A	400C	342.00	380.00	420.00	1	548.0	2.8	1
1.5ASMCJ440A	1.5ASMCJ440CA	440A	440C	376.00	418.00	462.00	1	602.0	2.5	1
1.5ASMCJ480A	1.5ASMCJ480CA	480A	480C	408.00	456.00	504.00	1	658.0	2.3	1
1.5ASMCJ510A	1.5ASMCJ510CA	510A	510C	434.00	485.00	535.00	1	698.0	2.1	1
1.5ASMCJ530A	1.5ASMCJ530CA	530A	530C	450.00	503.50	556.50	1	725.0	2.1	1
1.5ASMCJ540A	1.5ASMCJ540CA	540A	540C	459.00	513.00	567.00	1	740.0	2.0	1
1.5ASMCJ550A	1.5ASMCJ550CA	550A	550C	467.00	522.50	577.50	1	760.0	2.0	1

Note: For bi-directional type having V_{RWM} of 10 volts and less, the I_R limit is double.

Circuit Examples

Data Line Protection

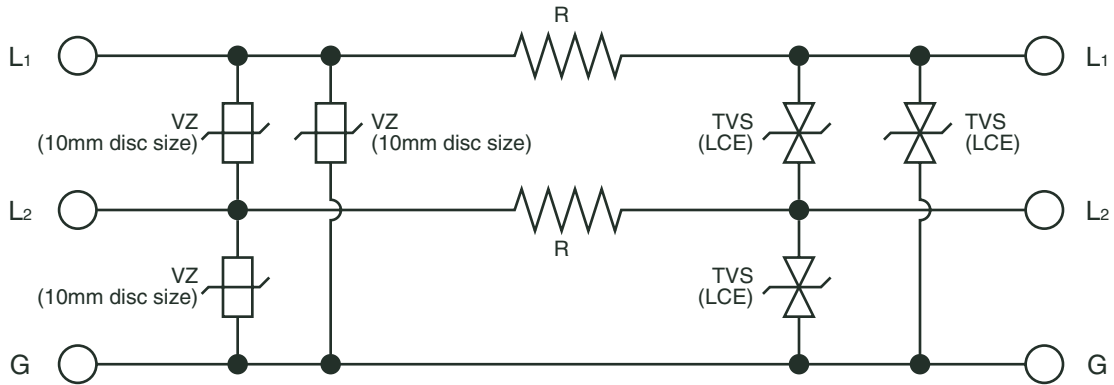

AC Line Protection

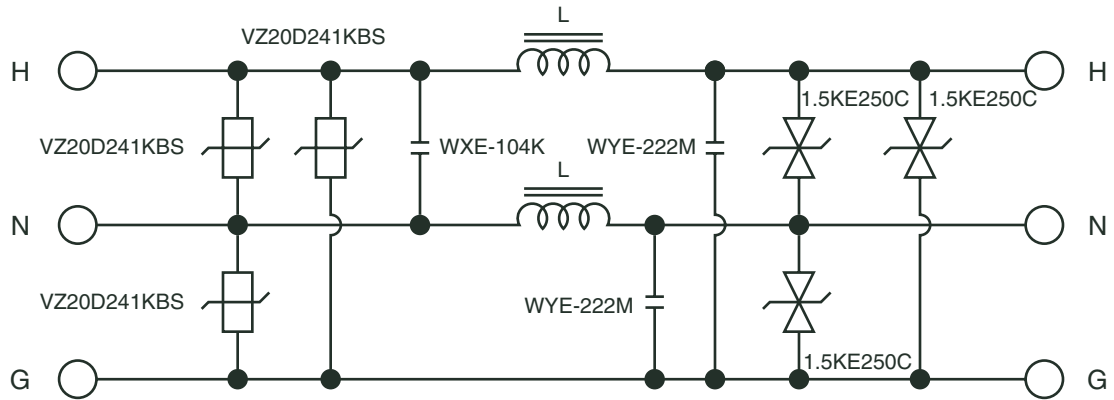

Telecom Circuit Protection

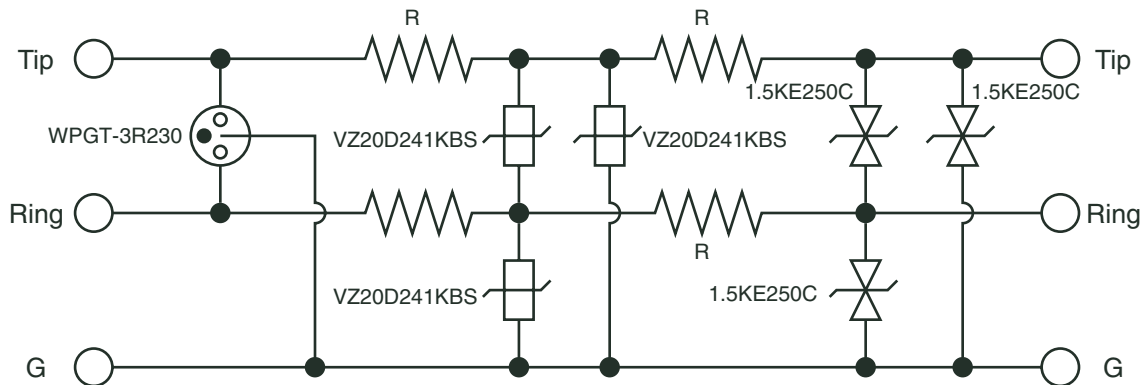

Applications

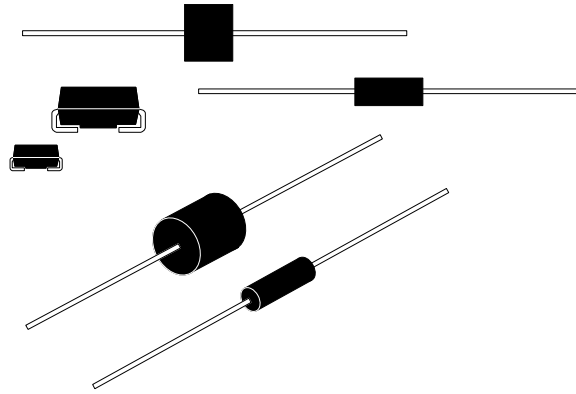

Transient Voltage Suppression Diodes or TVSD is a semiconductor diode with a single P-N junction which may operate in either direction and employs its breakdown characteristics as part of its function. This device limits (clamp) transient voltages and diverts transient currents.

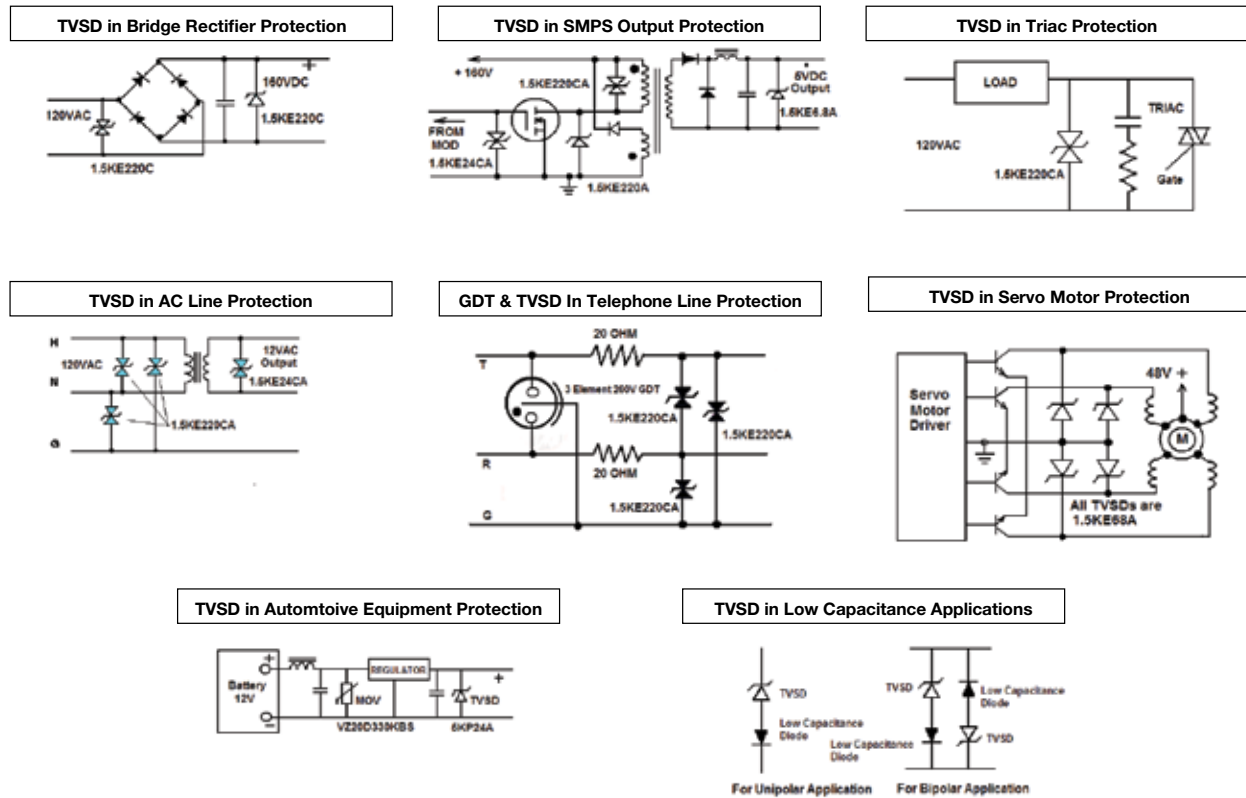

All application notes/circuits are shown as examples only. It is the responsibility of the purchaser to insure that the application meets purchaser's specifications. No representation or warranty, whether express or implied, is given and no liability is assumed by WPI with respect to the use of such examples.

WPI Reserves Copyright

DISCLAIMER: The names of the products and the specifications in this catalog are subject to change without notice for the sake of improvement. World Products, LLC also reserves the right to discontinue any of these products. The products in this catalog are intended for use in ordinary electronic products. If any of these products are to be used in special applications requiring extremely high reliability, where product defects might pose a safety risk, please consult World Products, LLC. Though World Products, LLC has taken all possible precautions to ensure the quality and reliability of its products, improper use of products may result in bodily injury, fire, or similar accident. If you have any questions regarding the use of the products in question, please consult World Products, LLC. Please be advised that World Products, LLC accepts no responsibility for any infringement by users of World Products, LLC products on third party patents or industrial copyrights.

THIS PAGE WAS INTENTIONALLY LEFT BLANK.