

## OMNIMATE Signal - series LL LL 9.52/03/90 5.0SN BK BX

**Weidmüller Interface GmbH & Co. KG**  
Klingenbergstraße 26  
D-32758 Detmold  
Germany  
Fon: +49 5231 14-0  
Fax: +49 5231 14-292083  
www.weidmueller.com

### Product image

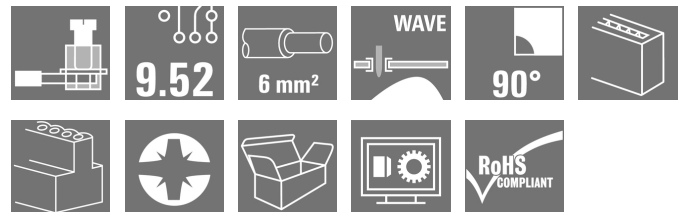

This PCB terminal provides connections for 1000 V, 6 mm<sup>2</sup> conductor cross-section and 32 A with proven clamping yoke connection at 9.52 mm pitch, conductor outlet direction in 90° design.

### General ordering data

Type	LL 9.52/03/90 5.0SN BK BX
Order No.	<a href="#">1724710000</a>
Version	Printed circuit board terminals, 9.52 mm, Number of poles: 3, 90°, Solder pin length (l): 5 mm, tinned, black, Clamping yoke connection, Clamping range, max. : 6 mm <sup>2</sup> , Box
GTIN (EAN)	4008 190959807
Qty.	100 pc(s).
Product data	IEC: 1000 V / 32 A / 0.18 - 6 mm <sup>2</sup> UL: 300 V / 30 A / AWG 26 - AWG 10
Packaging	Box

Creation date September 12, 2020 12:49:29 AM CEST

**OMNIMATE Signal - series LL**  
**LL 9.52/03/90 5.0SN BK BX**

**Weidmüller Interface GmbH & Co. KG**  
 Klingenbergstraße 26  
 D-32758 Detmold  
 Germany  
 Fon: +49 5231 14-0  
 Fax: +49 5231 14-292083  
 www.weidmueller.com

**Technical data****Dimensions and weights**

Width	29.16 mm	Width (inches)	1.148 inch
Height	26.5 mm	Height (inches)	1.043 inch
Height of lowest version	21.5 mm	Depth	12.5 mm
Depth (inches)	0.492 inch	Net weight	9.03 g

**System parameters**

Product family	OMNIMATE Signal - series LL	Wire connection method	Clamping yoke connection
Property, clamping point	WireReady	Mounting onto the PCB	THT solder connection
Conductor outlet direction	90°	Pitch in mm (P)	9.52 mm
Pitch in inches (P)	0.375 inch	Number of poles	3
Fitted by customer	Yes	Max. adjacent poles per row	12
Solder pin length (l)	5 mm	Solder pin dimensions	0.5 x 1.0 mm
Solder eyelet hole diameter (D)	1.3 mm	Solder eyelet hole diameter tolerance (D)+	0, 1 mm
Number of solder pins per pole	1	Screwdriver blade	0.8 x 4.0
Screwdriver blade standard	DIN 5264	Tightening torque, min.	0.5 Nm
Tightening torque, max.	0.6 Nm	Clamping screw	M 3
Stripping length	7 mm	L1 in mm	19.04 mm
L1 in inches	0.75 inch	Touch-safe protection acc. to DIN VDE 0470	IP 20
Touch-safe protection acc. to DIN VDE 57 106	Safe from finger touch		

**Material data**

Insulating material	Wemid (PA)	Colour	black
Colour chart (similar)	RAL 9011	Insulating material group	I
Comparative Tracking Index (CTI)	≥ 600	Insulation strength	≥ 10 <sup>8</sup> Ω
UL 94 flammability rating	V-0	GWIT	960 °C
GWFI	960 °C	Contact material	Copper alloy
Contact surface	tinned	Coating	4-6 µm SN
Tinning type	matt	Layer structure of solder connection	2...4 µm Ni / 4...6 µm Sn matt
Storage temperature, min.	-40 °C	Storage temperature, max.	70 °C
Operating temperature, min.	-50 °C	Operating temperature, max.	120 °C
Temperature range, installation, min.	-25 °C	Temperature range, installation, max.	120 °C

**Conductors suitable for connection**

Clamping range, min.	0.18 mm <sup>2</sup>
Clamping range, max.	6 mm <sup>2</sup>
Wire connection cross section AWG, min.	AWG 26
Wire connection cross section AWG, max.	AWG 10
Solid, min. H05(07) V-U	0.18 mm <sup>2</sup>
Solid, max. H05(07) V-U	6 mm <sup>2</sup>
Flexible, min. H05(07) V-K	0.22 mm <sup>2</sup>
Flexible, max. H05(07) V-K	4 mm <sup>2</sup>
w. plastic collar ferrule, DIN 46228 pt 4, min.	0.5 mm <sup>2</sup>
w. plastic collar ferrule, DIN 46228 pt 4, max.	2.5 mm <sup>2</sup>
w. wire end ferrule, DIN 46228 pt 1, min.	0.5 mm <sup>2</sup>

Creation date September 12, 2020 12:49:29 AM CEST

## OMNIMATE Signal - series LL LL 9.52/03/90 5.0SN BK BX

**Weidmüller Interface GmbH & Co. KG**  
Klingenbergstraße 26  
D-32758 Detmold  
Germany  
Fon: +49 5231 14-0  
Fax: +49 5231 14-292083  
www.weidmueller.com

## Technical data

w. wire end ferrule, DIN 46228 pt 1, max. 4 mm<sup>2</sup>

Plug gauge in accordance with EN 60999 a x b; ø 3.6 mm x 3.1 mm; 2.7 mm

Clampable conductor	Cross-section for conductor connection	Type	fine-wired
		nominal	0.5 mm <sup>2</sup>
wire end ferrule	Stripping length	nominal	6 mm
		Recommended wire-end ferrule	<a href="#">H0.5/6</a>
Cross-section for conductor connection	Type	fine-wired	
		nominal	1 mm <sup>2</sup>
wire end ferrule	Stripping length	nominal	6 mm
		Recommended wire-end ferrule	<a href="#">H1.0/6</a>
Cross-section for conductor connection	Type	fine-wired	
		nominal	1.5 mm <sup>2</sup>
wire end ferrule	Stripping length	nominal	7 mm
		Recommended wire-end ferrule	<a href="#">H1.5/7</a>
Cross-section for conductor connection	Type	fine-wired	
		nominal	2.5 mm <sup>2</sup>
wire end ferrule	Stripping length	nominal	7 mm
		Recommended wire-end ferrule	<a href="#">H2.5/7</a>
Cross-section for conductor connection	Type	fine-wired	
		nominal	0.75 mm <sup>2</sup>
wire end ferrule	Stripping length	nominal	6 mm
		Recommended wire-end ferrule	<a href="#">H0.75/6</a>

Reference text Length of ferrules is to be chosen depending on the product and the rated voltage.. The outside diameter of the plastic collar should not be larger than the pitch (P)

Max. clamping range 6 mm<sup>2</sup>

### Rated data acc. to IEC

tested acc. to standard	IEC 60664-1, IEC 61984	Rated current, min. number of poles (Tu=20°C)	32 A
Rated current, max. number of poles (Tu=20°C)	32 A	Rated current, min. number of poles (Tu=40°C)	32 A
Rated current, max. number of poles (Tu=40°C)	32 A	Rated voltage for surge voltage class / pollution degree II/2	1,000 V
Rated voltage for surge voltage class / pollution degree III/2	1,000 V	Rated voltage for surge voltage class / pollution degree III/3	690 V
Rated impulse voltage for surge voltage class/ pollution degree II/2	6 kV	Rated impulse voltage for surge voltage class/ pollution degree III/2	8 kV
Rated impulse voltage for surge voltage class/ contamination degree III/3	8 kV	Short-time withstand current resistance	3 x 1s with 120 A

**OMNIMATE Signal - series LL**  
**LL 9.52/03/90 5.0SN BK BX**

**Weidmüller Interface GmbH & Co. KG**  
 Klingenbergstraße 26  
 D-32758 Detmold  
 Germany  
 Fon: +49 5231 14-0  
 Fax: +49 5231 14-292083  
 www.weidmueller.com

**Technical data****Rated data acc. to CSA**

Institute (CSA)		Certificate No. (CSA)	200039-1815154
Rated voltage (Use group B / CSA)	300 V	Rated voltage (Use group C / CSA)	300 V
Rated current (Use group B / CSA)	30 A	Rated current (Use group C / CSA)	35 A
Wire cross-section, AWG, min.	AWG 26	Wire cross-section, AWG, max.	AWG 10
Reference to approval values	Specifications are maximum values, details - see approval certificate.		

**Rated data acc. to UL 1059**

Institute (cURus)		Certificate No. (cURus)	E60693
Rated voltage (Use group B / UL 1059)	300 V	Rated voltage (Use group C / UL 1059)	300 V
Rated current (Use group B / UL 1059)	30 A	Rated current (Use group C / UL 1059)	30 A
Wire cross-section, AWG, min.	AWG 26	Wire cross-section, AWG, max.	AWG 10
Reference to approval values	Specifications are maximum values, details - see approval certificate.		

**Packing**

Packaging	Box	VPE length	47 mm
VPE width	134 mm	VPE height	313 mm

**Classifications**

ETIM 6.0	EC002643	ETIM 7.0	EC002643
eClass 9.0	27-44-04-01	eClass 9.1	27-44-04-01
eClass 10.0	27-44-04-01	UNSPSC	30-21-18-01

**Notes**

Notes	<ul style="list-style-type: none"> <li>Rated current related to rated cross-section &amp; min. No. of poles.</li> <li>Wire end ferrule without plastic collar to DIN 46228/1</li> <li>Wire end ferrule with plastic collar to DIN 46228/4</li> <li>The data given under CSA relates to a cUL approval - E60693</li> <li>P on drawing = pitch</li> <li>Rated data refer only to the component itself. Clearance and creepage distances to other components are to be designed in accordance with the relevant application standards.</li> <li>Long term storage of the product with average temperature of 50 °C and average humidity 70%, 36 months</li> </ul>
IPC conformity	Conformity: The products are developed, manufactured and delivered according international recognized standards and norms and comply with the assured properties in the data sheet resp. fulfill decorative properties in accordance with IPC-A-610 "Class 2". Further claims on the products can be evaluated on request.

Creation date September 12, 2020 12:49:29 AM CEST

Catalogue status 28.08.2020 / We reserve the right to make technical changes.

**Data sheet**

**OMNIMATE Signal - series LL**  
**LL 9.52/03/90 5.0SN BK BX**

**Weidmüller Interface GmbH & Co. KG**  
 Klingenbergstraße 26  
 D-32758 Detmold  
 Germany  
 Fon: +49 5231 14-0  
 Fax: +49 5231 14-292083  
 www.weidmueller.com

**Technical data**

**Approvals**

Approvals



ROHS

Conform

**Downloads**

Approval/Certificate/Document of  
 Conformity

[Declaration of the Manufacturer](#)

Brochure/Catalogue

- [FL DRIVES EN](#)
- [MB DEVICE MANUF. EN](#)
- [FL DRIVES DE](#)
- [FL APPL INVERTER EN](#)
- [FL\\_BASE\\_STATION\\_EN](#)
- [FL ELEVATOR EN](#)
- [FL POWER SUPPLY EN](#)
- [FL 72H SAMPLE SER EN](#)
- [PO OMNIMATE EN](#)

Engineering Data

[WSCAD](#)

User Documentation

[QR-Code product handling video](#)

**Data sheet**

**OMNIMATE Signal - series LL  
LL 9.52/03/90 5.0SN BK BX**

**Weidmüller Interface GmbH & Co. KG**  
Klingenbergstraße 26  
D-32758 Detmold  
Germany  
Fon: +49 5231 14-0  
Fax: +49 5231 14-292083  
www.weidmueller.com

**Drawings**

**Dimensional drawing**

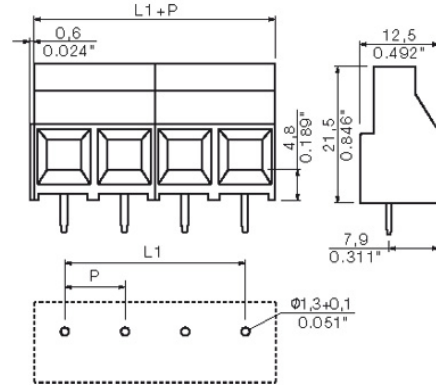

**Graph**

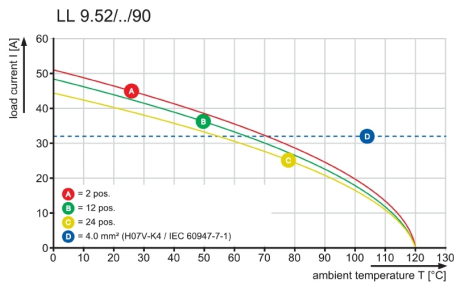

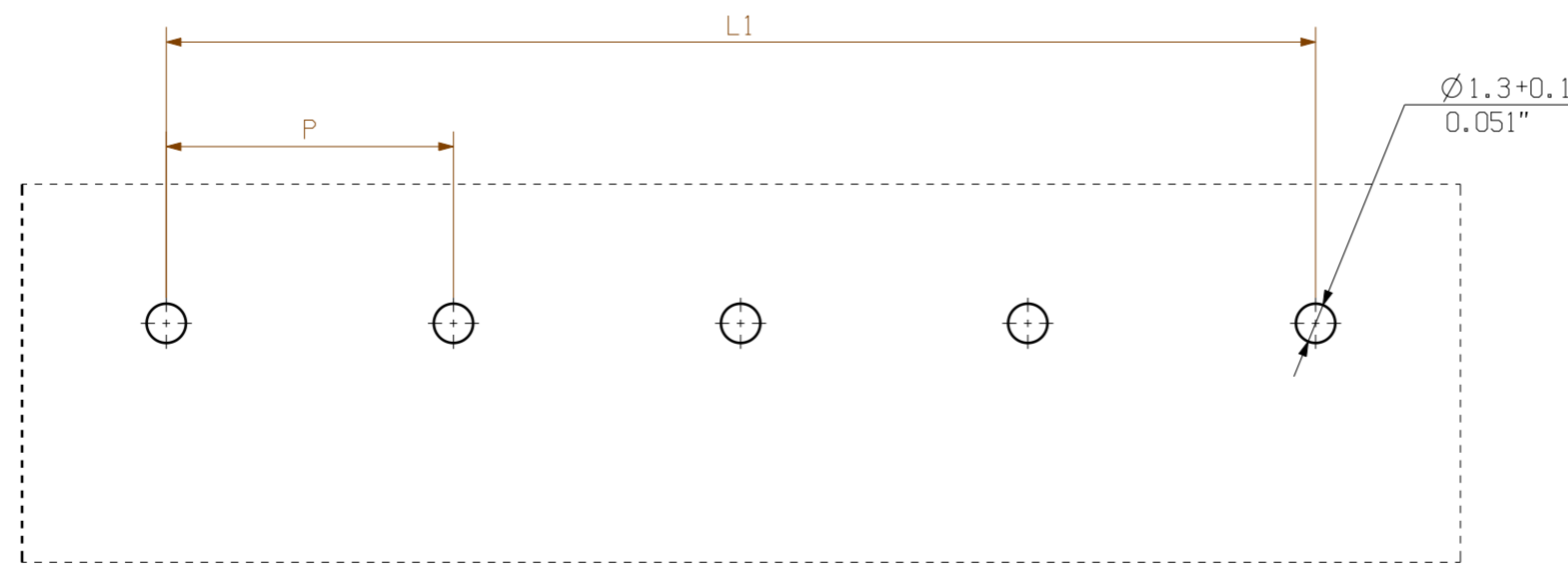
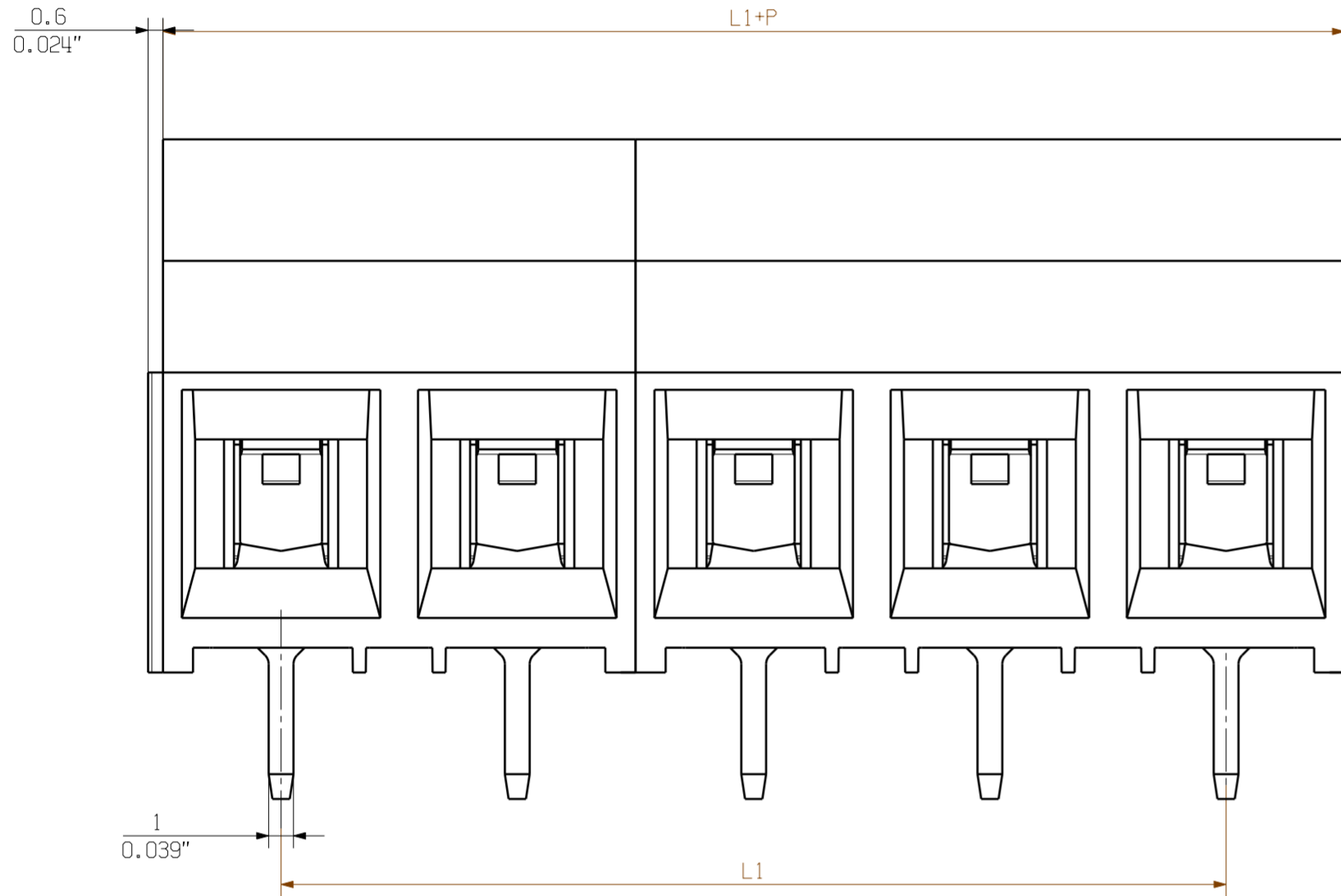
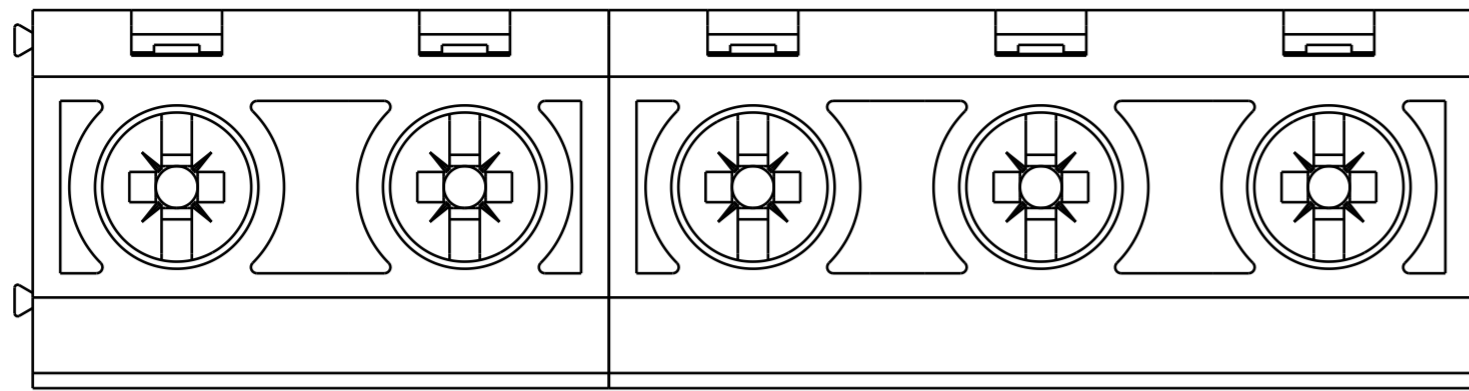

PCB LAYOUT

Customer drawing

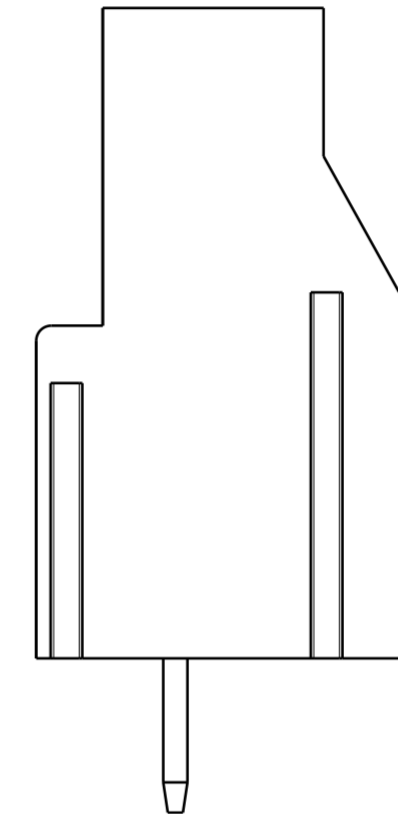
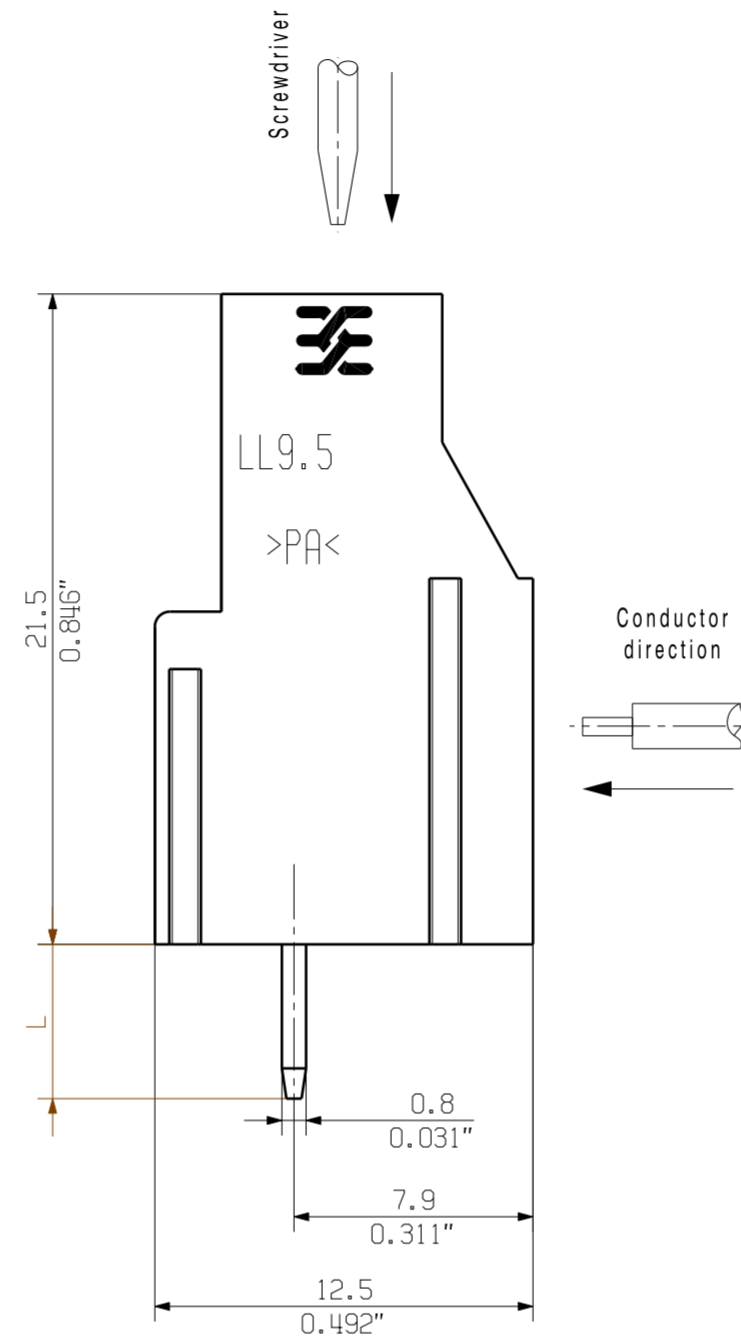

Pin length L	Tolerance
5.0	0.10 -0.25

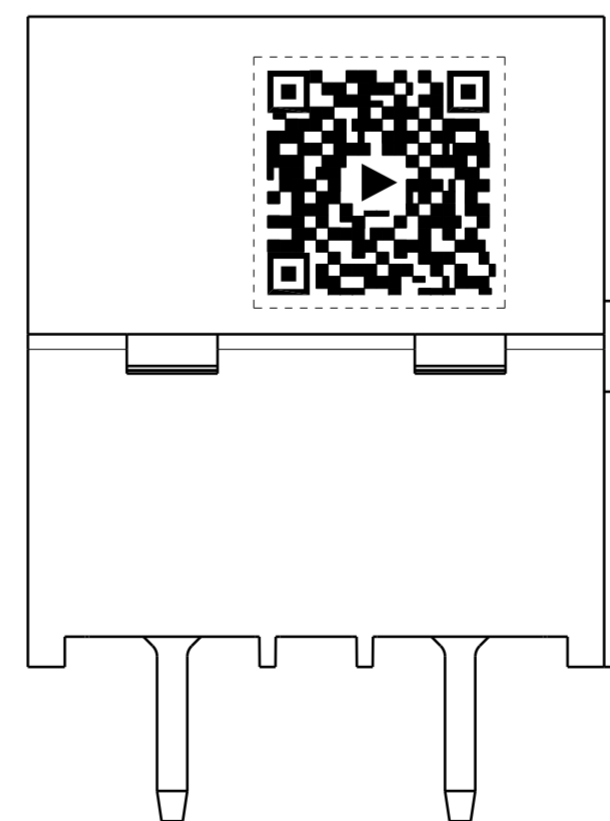

P = 9.52<sub>0.375</sub> inch Pitch

12	104.72	4.125
11	95.20	3.750
10	85.68	3.375
9	76.16	3.000
8	66.64	2.625
7	57.12	2.250
6	47.60	1.875
5	38.08	1.500
4	28.56	1.125
3	19.04	0.750
2	9.52	0.375
N	L1 [mm]	L1 [inch]
P	9.52 mm	0.375 inch

For the mounting of PCBs, it should be noted that the rated data relates only to the PCB components alone. The necessary creepage and clearance paths must be observed in connection with the respective applicant in accordance to IEC 60664-1 (VDE 0113). The current-carrying capacity and pitch tolerance is to be determined according to DIN IEC 60326-3 very fine.

Weidmüller PCB components are tested to the IEC 60947-7-4 standard, and are valid for its field of application. Provided that the components are used to the intended purpose, all requirements with respect to the occurring of electrical, mechanical, thermic and corrosive stress will be satisfied.

GENERAL TOLERANCE:  
DIN ISO 2768-m

	EC00000683	00	Prim PLM Part No.: 026319	Prim ERP Part No.: 1912970000
	First Issue Date 14.05.2018	Max. nos.	<b>41724</b>	
Modification	Modification			
	Date	Name	<b>LL 9.52/.../90 ...</b> LEITERPLATTENKLEMME PCB TERMINAL	
	Drawn	03.12.2018		
Scale: 4/1	Size: A2	Responsible	Xiang, Keqin	Drawing no. <b>41724</b> Issue no. <b>10</b> Sheet 01 of 01 sheets
Drawings Assembly	Approved	04.12.2018	Xu, Shary	
Product file: 7066 LL 9.52				

The reproduction, distribution and utilization of this document as well as the communication of its contents to others without explicit authorization is prohibited. Offenders will be held liable for the payment of damages. Weidmüller exclusively reserves the right to file for patents, utility models or designs.

© Weidmüller Interface GmbH & Co. KG

## Recommended wave soldering profiles

**Weidmüller Interface GmbH & Co. KG**  
 Klängenbergstraße 16  
 D-32758 Detmold  
 Germany  
 Fon: +49 5231 14-0  
 Fax: +49 5231 14-292083  
 www.weidmueller.com

### Single Wave:



### Double Wave:



### Wave soldering profiles

Wired connection elements should be processed in accordance with the DIN EN 61760-1 standard. We have included two recommendations for practical wave soldering profiles, with which Weidmüller PCB terminals and connectors are qualified.

When choosing a suitable profile for your application, the following factors also need to be considered:

- PCB thickness
- Proportion of Cu in the layers
- Single/double-sided assembly
- Product range
- Heating and cooling rates

The single and double wave profiles each indicate the recommended operating range, including the maximum soldering temperature of 260°C. In practice, the maximum soldering temperature is quite often well below the above maximum profile.



