

**Data sheet | Item number: 216-301**

Ferrule; Sleeve for 0.25 mm<sup>2</sup> / AWG 24; insulated; electro-tin plated; yellow

[www.wago.com/216-301](http://www.wago.com/216-301)

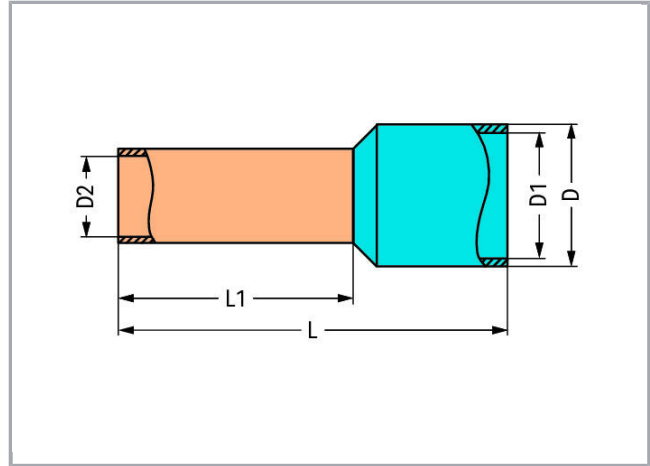

Subject to changes.

WAGO Kontakttechnik GmbH & Co. KG  
Hansastr. 27  
32423 Minden  
Phone: +49571 887-0 | Fax: +49571 887-169  
Email: [info.de@wago.com](mailto:info.de@wago.com) | Web: [www.wago.com](http://www.wago.com)

Do you have any questions about our products?  
We are always happy to take your call at +49 (571) 887-44222.



Subject to changes.

RoHS   
Compliant

BOMcheck.net

Color: **Data****Technical Data**

Main product function	Ferrule
Querschnitt Hülse AWG	24 AWG
Hülse für	0.25 mm <sup>2</sup>

**Connection data**

Strip length	9 mm / 0.35 inch
--------------	------------------

**Geometrical Data**

Length	12 mm
Length 1	8 mm
Diameter	2.3 mm
Diameter 1	1.8 mm
Diameter 2	0.5 mm

**Material Data**

Color	yellow
Fire load	0.001 MJ
Weight	0.1 g

**Commercial data**

Product Group	2 (Terminal Block Accessories)
Packaging type	BOX
Country of origin	DE
GTIN	4017332277396
Customs Tariff No.	85369010000

Subject to changes.

## Downloads Documentation

### Bid Text

216-301 doc - Datei	Sep 11, 2017	doc 24.1 kB	Download
216-301 X81 - Datei	Feb 19, 2019	xml 2.9 kB	Download

## Installation Notes

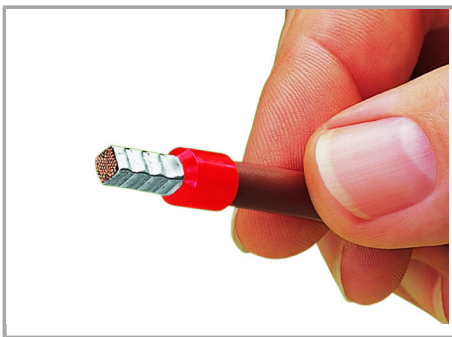

A perfect gas-tight crimp – both electrically and mechanically reliable

Subject to changes.