

Broadcast and Entertainment Products

Audio Patching Systems

2nd Edition



Tyco Electronics and ADC are now **TE Connectivity**



Table of Contents

7 / 1 2 • 1 0 8 9 4 3 A E Broadcast and Entertainment Products

ProPatch® Programmable (PPP) Series

Overview	2.1
Individual Jack Access	2.2
Bantam and Longframe Chassis and Modules	2.3
Ordering Information.....	2.5
Jacks and Accessories	2.8
Ordering Information.....	2.10

ProPatch® Professional (PPA and PPB) Series

Patchbays and Jackfields	2.11
Jacks.....	2.14
QCP II and QCP IV Termination Systems	2.15
Ordering Information.....	2.16

ProPatch® Umbilical (BJF) Series

Jackfields.....	2.17
Ordering Information.....	2.19

ProPatch® Lite (PPA and PPB) Series

Solder-Style Panels	2.20
Ordering Information.....	2.21

Accessories

High Performance Audio Patch Cords	2.22
Longframe Audio Plugs.....	2.23
Bantam Audio Plugs	2.24
Longframe and Bantam Audio Jacks	2.24
Audio Baluns	2.26
Designation Strip Kits.....	2.26
QCP and EDAC Tools and Accessories	2.26
ProPatch Cord Holder	2.26
Ordering Information.....	2.27



Audio Patching Systems

ProPatch® Programmable (PPP) Series



7/12 • 108943AE Broadcast and Entertainment Products

The ProPatch® Programmable modular system offers unprecedented reliability and flexibility in a convenient, space-saving size and lightweight package. Specifically engineered for everyday use in demanding mobile trucks, the ProPatch Programmable system is the only product in its class that passes stringent MIL-STD-202F standards for vibration and environmental requirements.

The ProPatch Programmable bantam system is a WECO-standard module in a high-density 2x48 one rack space panel. The longframe system is a WECO-standard module in either a 2x24 or high-density 2x32 one rack space configuration. The modular design allows individual front jack access for circuit and ground configurations without having to take the entire panel offline or removing it from the rack. Each modular jack features WECO gold crossbar contacts that provide self-cleaning action and maximize reliability. Jack modules are also individually sealed which prevents dust and contamination from convection plenum action common in rack mounted systems.

The ProPatch Programmable series is available with a variety of termination options including QCP punchdown, LSA-PLUS® punchdown, 3-pin, 56-pin, 90-pin, 120-pin EDAC/ELCO connectors, and 50-pin AMP “champ” connectors, in both an eight-connector version for audio and a four-connector version for RTS/ClearCom type intercom systems.

Only five inches deep and 6.2 pounds fully configured, the ProPatch Programmable series is unmatched in the marketplace. Using ADC's patent-pending escutcheon kit, the one rack unit panel can be converted to a 1.5 rack unit configuration. This allows the use of ADC's ultra-large designation strips, providing room for three lines of text, plus markers—the largest designations on the market.

Individual Jack Access

Each ProPatch Programmable panel features individual jack cards. Cards contain an individual circuit pair of jacks, front panel circuit status snap-in icon, and seven-position gold plated sealed DIP switch for normal and ground configuration. The gold-plated header card plugs and sockets contained in the chassis ensure maximum reliability.

To remove a jack, remove the top and bottom designation strips, push down the locking tab on the jack module and slide the module out from the front of the chassis. It is not necessary to remove the entire panel from the rack, or the cover from the chassis. Unauthorized circuit changes are eliminated because switches are hidden from front panel view.

The ProPatch Programmable system is the only product in its class that passes demanding MIL-202 environmental testing for thermal shock, resistance from moisture contamination, plating corrosion from salt fog, and vibration to simulate long-term fixed installation and over-the-road use.



Bantam

ProPatch Programmable panel allows individual front-panel jack access for normals and grounds without having to take the entire panel off-line. Special 7-position DIP switches allows configuration of the circuit normal and grounds without cumbersome jumpers or pins to lose. (See-through cover in photo is for demonstration purposes only.)



Longframe

Features

- Industry's only bantam and longframe audio panel fully qualified to meet demanding military standards (MIL-STD 202F for ruggedness, and MIL-J-641E for jack compliance)
- Lightweight panels weigh only 6.2 pounds (2.8 kg)
- High-density bantam 2x48 WECO-compliant bantam jacks on 0.312-inch centers
- High-density 2x32 or 2x24 longframe jack on .500-inch centers
- Gold plated DIP switch selectable circuit normals and grounds
- Shallow depth chassis determined by connector style
- Fully AES/EBU 110 W digital and analog compliant
- Modular design allows individual jack access/configuration without affecting other circuits
- Grounds can be configured on an individual circuit basis for lift, chassis, sleeve, and common ground
- Modules snap into place, tabs lock into chassis
- Circuit status icons allow users to identify circuit status with snap-in icons in eight colors
- Designation strips cover tabs to prevent unauthorized access to circuit configuration switches
- Converts to a 1.5 rack unit panel with a patent-pending escutcheon kit
- Largest designations on the market
Bantam: .410" for 1 RU
Longframe: .313" for 1 RU
Bantam and Longframe: .680" for 1.5 RU

Bantam and Longframe Chassis and Module Specifications

ELECTRICAL

Contact resistance:	0.020 Ω max (initial) 0.020 Ω max (after life cycling) 0.10 Ω max (after salt spray)
Insulation resistance:	10,000 M Ω min (initial) 1,000 M Ω min (after moisture resistance test)
Dielectric withstanding:	Voltage: 500 Vac
Contact rating:	Max: 100 mA + 130 Vdc; Min: -40 dBm

MECHANICAL

Mechanical shock:	Per MIL-STD-202F, Method 213B, test condition H
Vibration:	MIL-STD-1344, Method 2005, test condition I
Insertion force:	7 lbs (3.17 kg) max
Withdrawal force:	1.5 lbs (.679 kg) min
Life:	20,000 insertion/withdrawal cycles min

ENVIRONMENTAL

Operating temperature:	-40° to 65° C (-40° to 149° F)
Storage temperature:	-55° to 85° C (-67° to 185° F)
Thermal shock:	Per MIL-STD-202F, Method 107G, test condition A
Operating humidity:	0% to 95% (no condensation)
Storage humidity:	0% to 95% (no condensation)
Salt spray:	Per MIL-STD-202F, Method 101D
Moisture resistance:	Per MIL-STD-202F, Method 106E

MATERIALS

Chassis frame:	Steel, zinc plated with electroless nickel plating
Jack frame:	Unreinforced polyetherimide resin rated UL 94-V0 for flammability
Springs:	Nickel-silver
Contacts:	WECO No. 1 gold crossbar alloy welded to springs
PC boards:	FR-4
Sockets:	Phosper bronze 30 micro inches gold on contact
Switches:	Copper alloy 10 micro inches min gold on contact

Bantam Chassis Dimensions

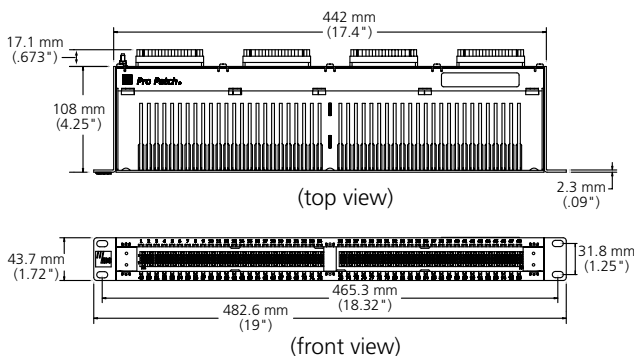

Typical 1 RU 48-Position Panel

Longframe Chassis Dimensions

7/12 • 108943AE Broadcast and Entertainment Products

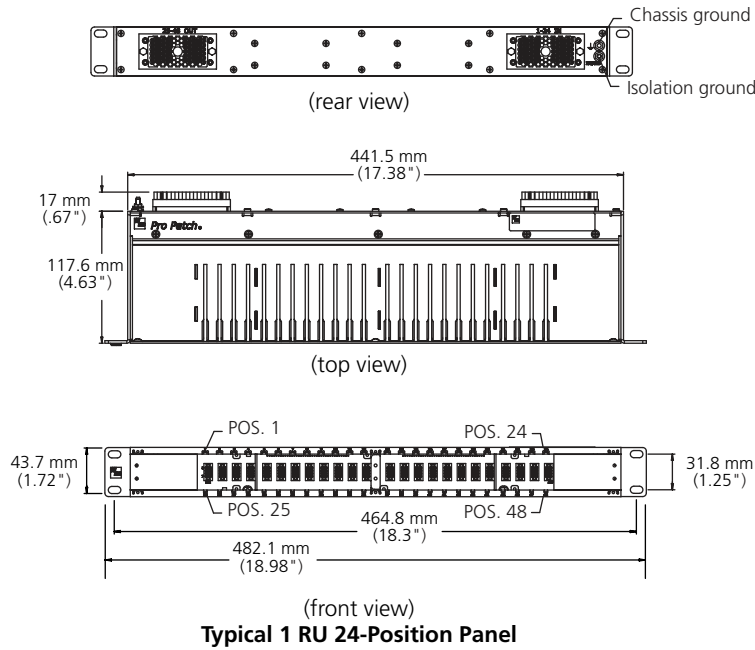
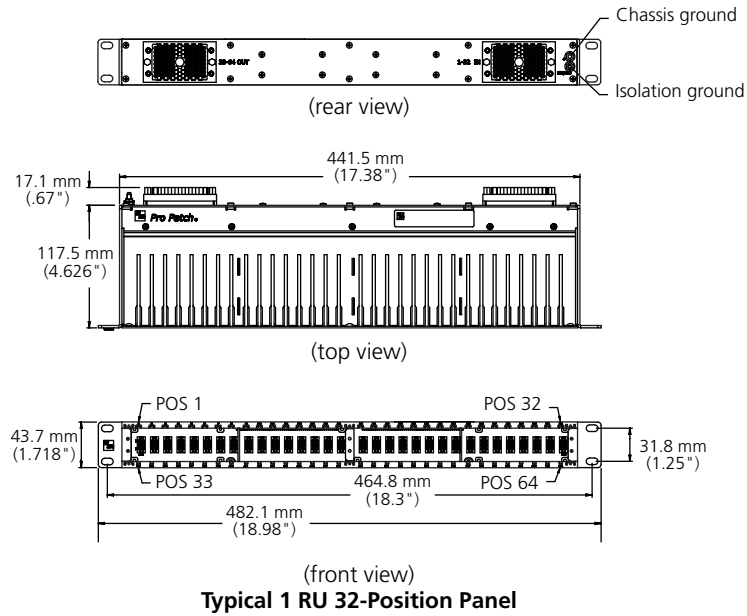



2x48 Bantam Panel
(shown with designation)

Ordering Information

Description		Catalog Number
2x48 Bantam Panels		
EDAC 3-Pin	Loaded chassis configured:	
	Half normalled	PPP1248-E3-HN
	Half normalled, with mating connector kit	PPP1248-E3-HN-S
	No normals	PPP1248-E3-NN
	No normals, with mating connector kit	PPP1248-E3-NN-S
	Normals strapped	PPP1248-E3-NS
	Normals strapped, with mating connector kit	PPP1248-E3-NS-S
	Empty chassis	PPP1248-E3
Empty chassis, with mating connector kit	PPP1248-E3-S	
EDAC 90-Pin	Loaded chassis configured:	
	Half normalled	PPP1248-E90-HN
	Half normalled, with mating connector kit	PPP1248-E90-HN-S
	Normals strapped	PPP1248-E90-NS
	Normals strapped, with mating connector kit	PPP1248-E90-NS-S
Empty chassis	PPP1248-E90	
AMP 50 8 connectors	Loaded chassis configured: Normals strapped	
	Empty chassis	PPP1248-A50
AMP 50 (Intercom) 4 connectors	Loaded chassis configured:	
	Half normalled	PPP1248-ICA50-HN
	Normals strapped	PPP1248-ICA50-NS
Empty chassis	PPP1248-ICA50	
QCP MKII	Loaded chassis configured:	
	Half normalled	PPP1248-QCP-HN
	Normals strapped	PPP1248-QCP-NS
	Empty chassis	PPP1248-QCP



EDAC 3-pin Chassis
PPP1248-E3-NS (rear view)



EDAC 90-pin Chassis
PPP1248-E90-NS (rear view)

7/12 • 108943AE Broadcast and Entertainment Products



2x32 Longframe Panel
(front view)

Ordering Information

Description		Catalog Number
2x32 Longframe Panels		
EDAC 3-Pin	Loaded chassis configured:	
	Half normalled	PPP1232-E3-HN
	Half normalled, with mating connector kit	PPP1232-E3-HN-S
	Empty chassis	PPP1232-E3
	No normals	PPP1232-E3-NN
	No normals, with mating connector kit	PPP1232-E3-NN-S
	Normals strapped	PPP1232-E3-NS
	Normals strapped, with mating connector kit	PPP1232-E3-NS-S
LSA-PLUS®	Loaded chassis configured:	
	Half normalled	PPP1232-LSA-HN
	Normals strapped	PPP1232-LSA-NS
	Empty chassis	PPP1232-LSA
QCP MKII	Loaded chassis configured:	
	Half normalled	PPP1232-QCP-HN
	Normals strapped	PPP1232-QCP-NS
	Empty chassis	PPP1232-QCP

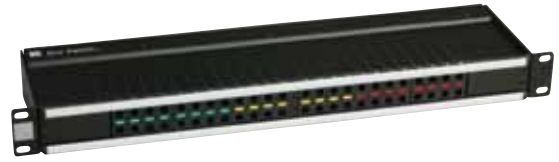

2x24 Longframe Panel
(front view)

Ordering Information

Description		Catalog Number
2x24 Longframe Panels		
EDAC 90-Pin	Loaded chassis configured:	
	Half normalled	PPP1224-E90-HN
	Half normalled, with mating connector kit	PPP1224-E90-HN-S
	Normals strapped	PPP1224-E90-NS
	Normals strapped, with mating connector kit	PPP1224-E90-NS-S
	Empty chassis	PPP1224-E90
LSA-PLUS®	Loaded chassis configured:	
	Half normalled	PPP1224-LSA-HN
	Normals strapped	PPP1224-LSA-NS
	Empty chassis	PPP1224-LSA
QCP MKIV	Loaded chassis configured:	
	Half normalled	PPP1224-MKIV-HN
	Normals strapped	PPP1224-MKIV-NS
	Empty chassis	PPP1224-MKIV
QCP MKII	Loaded chassis configured:	
	Half normalled	PPP1224-QCP-HN
	Normals strapped	PPP1224-QCP-NS
	Empty chassis	PPP1224-QCP



QCP MKII Chassis
(rear view)



LSA-PLUS Chassis
(rear view)

PJ339 and PJ482 Longframe Audio Jack Specifications

ELECTRICAL

Contact Resistance:	0.020 Ω maximum (initial) 0.020 Ω maximum (after life cycling) 0.10 Ω maximum (after salt spray)
Insulation Resistance:	10,000 meg Ω s minimum (initial) 1,000 meg Ω s minimum (after moisture resistance test)
Dielectric Withstanding:	Voltage: 500 Vac
Contact Rating:	Maximum: 100 mA + 130 Vdc; Minimum: -40 dBm

MECHANICAL

Mechanical Shock:	Per MIL-STD-202F, Method 213B, test condition H
Vibration:	MIL-STD-1344, Method 2005, test condition I
Insertion Force:	7 lbs. (3.17 kg) maximum
Withdrawal Force:	1.5 lbs. (.679 kg) minimum
Life:	20,000 insertion/withdrawal cycles minimum

ENVIRONMENTAL

Operating Temp:	-40° C to 65° C
Storage Temp:	-55° C to 85° C
Thermal Shock:	Per MIL-STD-202F, Method 107G, test condition A
Operating Humidity:	0% to 95% (no condensation)
Storage Humidity:	0% to 95% (no condensation)
Salt Spray:	Per MIL-STD-202F, Method 101D
Moisture Resistance:	Per MIL-STD-202F, Method 106E

MATERIALS

Frame:	Steel, zinc plated with electroless nickel plating
Sleeve:	Brass, nickel plated
Insulators:	Unreinforced polyetherimide resin rated UL 94-V0 for flammability
Springs:	Nickel-silver
Contacts:	WECO No. 1 gold crossbar alloy welded to springs
Solder Lugs:	Hot tin dipped

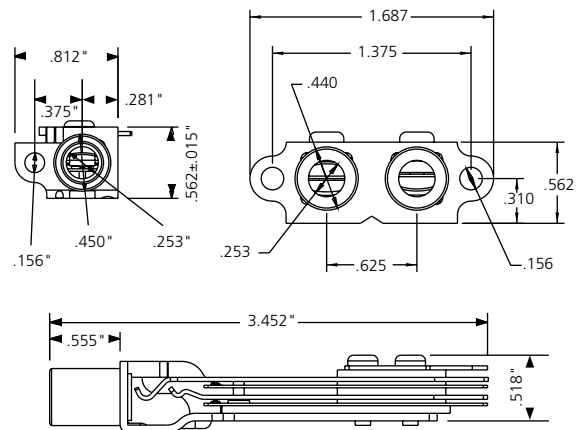
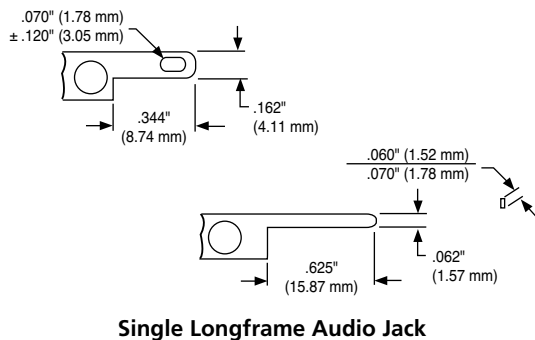
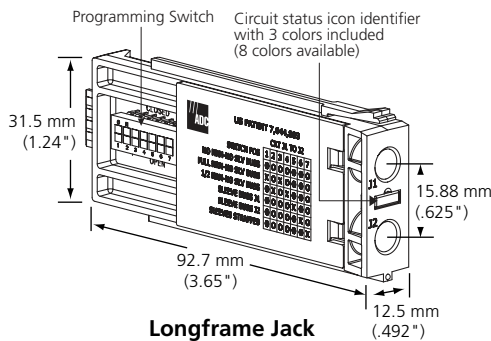

PJ839 and PJ889 Bantam Audio Jack Specifications

ELECTRICAL

Contact Resistance:	0.020 Ω maximum (initial) 0.020 Ω maximum (after life cycling) 0.10 Ω maximum (after salt spray)
Insulation Resistance:	10,000 meg Ω s minimum (initial) 1,000 meg Ω s minimum (after moisture resistance test)
Dielectric Withstanding:	
Voltage:	500V RMS
Contact Rating:	Maximum: 100 mA \pm 130 Vdc; Minimum: -40 dBm

MECHANICAL

Mechanical Shock:	Per MIL-STD-202F, Method 213B, test condition H
Vibration:	MIL-STD-1344, Method 2005, test condition I
Insertion Force:	7 lbs. (3.17 kg) maximum
Withdrawal Force:	1.5 lbs. (.679 Kg) minimum
Life:	20,000 insertion/withdrawal cycles minimum

ENVIRONMENTAL

Operating Temp:	-40° C to 65° C
Storage Temp:	-55° C to 85° C
Thermal Shock:	Per MIL-STD-202F, Method 107G, test condition A
Operating Humidity:	0% to 95%, non-condensing
Storage Humidity:	0% to 95%, non-condensing
Salt Spray:	Per MIL-STD-202F, Method 101D
Moisture Resistance:	Per MIL-STD-202F, Method 106E

MATERIALS

Frame:	Zinc die-cast zinc plated with electroless nickel plating
Insulators:	Unreinforced polyetherimide resin rated UL 94-V0 for flammability
Springs:	Nickel-Silver alloy
Contacts:	WECO No. 1 gold crossbar alloy welded to springs

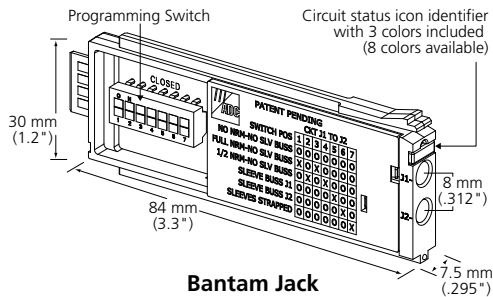

Bantam Jack

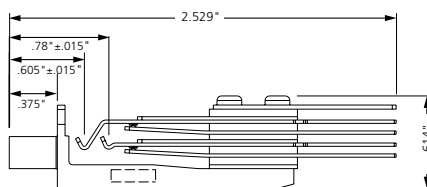
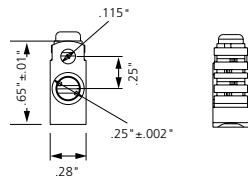

Three-Conductor Single Bantam Jack

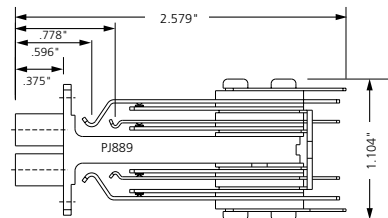
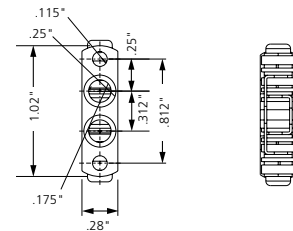

Three-Conductor Dual Bantam Jack

Audio Patching Systems

ProPatch® Programmable (PPP) Series

Jacks and Accessories



Bantam Jack
(AM1-BAN)



Longframe Jack
(AM-LF1)



1.5 RU Chassis Conversion Kit
(PPP-15-CHAS-KIT)

Ordering Information

Description	Catalog Number
Programmable Audio Jacks	
Bantam	AM1-BAN
Longframe	AM-LF1
1.5 RU Chassis Conversion Kit for Bantam and Longframe	PPP-15-CHAS-KIT
Designation Kits	
11.2 mm (.44")	VP-DES-440
17.3 mm (.68")	VP-DES-680-B
35.6 mm (1.4")	VP-DES-1400-B



Audio Patching Systems

ProPatch® Professional (PPA and PPB) Series

Patchbays and Jackfields

ProPatch professional audio patchbays and broadcast jackfields feature an extensive selection of jacks, panel sizes, normalling options, and rear terminations. Each panel contains ADC's high-quality, WECO-standard, frame-type jacks and includes a tough powder-coated chassis with built-in cable support and designation strips. Solderless internal wiring and terminations ensure completely dependable performance without intermittents. Termination options include the extremely reliable and quick-to-wire QCP II or QCP IV punchdown system as well as EDAC and AMP connector options.

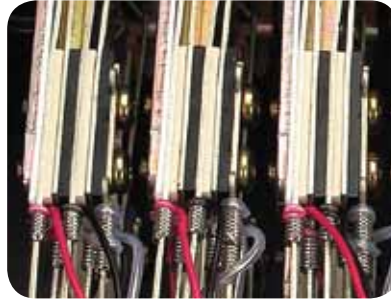

7/12 • 108943AE Broadcast and Entertainment Products

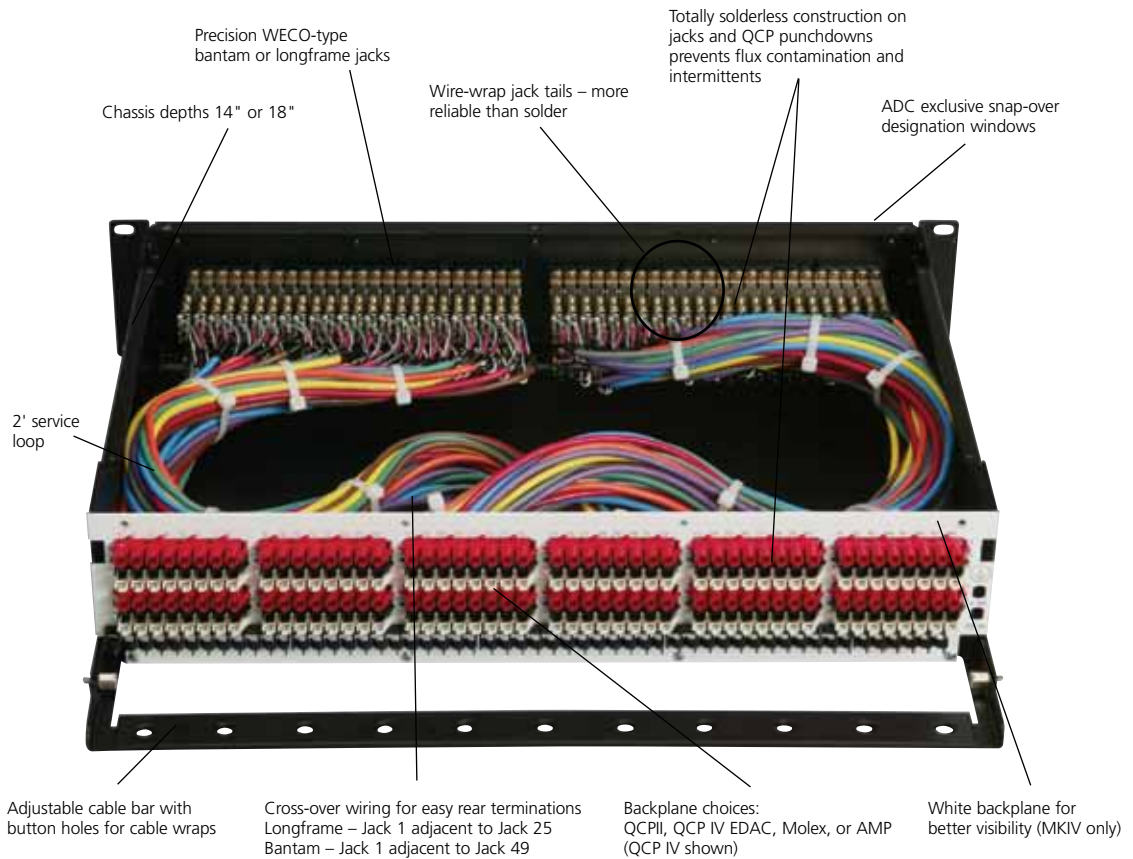



Audio Patching Systems

ProPatch® Professional (PPA and PPB) Series

Ready to meet any analog or digital audio patching requirement, ProPatch professional audio patchbays offer an extensive selection of options. Models are available with standard or stereo-spaced longframe jacks, bantam jacks, and a variety of backplane connector types. MKII models come with QCP II, EDAC, or AMP backplane connectors and fixed cable support bars. MKIV models include QCP IV, EDAC, or AMP backplane connectors, adjustable cable support bars and a white backplane for easier circuit visibility. All models offer a wide choice of normals, a tough powder-coated chassis, and solderless internal wiring for outstanding reliability.

7/12 • 108943AE Broadcast and Entertainment Products



**1 RU Longframe Evenly Spaced 2x24
(front view)**
(PPA1-14MKIVNS)



**2 RU Bantam Evenly Spaced 2x48
(front view)**
(PPB3-14MKIVNS)

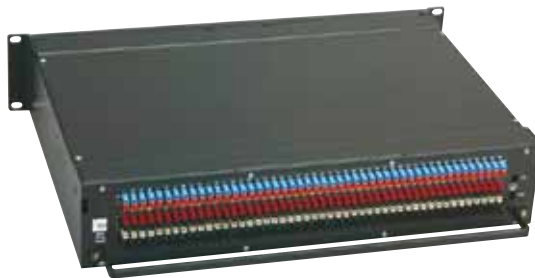

**2 RU Bantam Evenly-Spaced 2x24
(rear view)**
(PPB3-14MKIINO)

Features

Next Generation ProPatch Audio Jackfields

- Analog and digital compatible—all wired with precision 110 low capacitance cable for extended analog frequency response and extended distance digital transmission (no need to specify type)
- Uniform faceplate design with standardized designation strip lengths provides a seamless appearance when matched with video panels (over and under designation)
- New lighter one-piece chassis design
- Adjustable cable strain relief bar—tilts out of way for installation access
- High impact plastic injected molded jack inserts—more durable than phenolic materials
- Standard Bantam jackfields come with regular (even) spaced inserts—stereo (group) spacing available

Longframe or Bantam Jacks

- Longframe jacks in 2x24 array regular spaced
- Bantam jacks in 2x48 array stereo or regular spaced

Digital Audio Cable Wiring

- Precision 110 Ω digital audio cable meets and exceeds stringent AES requirements

Variety of Jack Options

- Standard longframe jacks (evenly spaced)
- High-density bantam jacks, regular or spaced (stereo-spaced option available)
- Stereo-spacing option places jacks in pairs

Standard or Custom Sizes

- 1 RU (1.75"/44.5 mm)
- 2 RU (3.5"/88 mm)
- Depths of 14 inches (350 mm)

Wide Selection of Terminations

- Patented QCP II or QCP IV punchdown connectors
- EDAC/ELCO 90-, and 3-pin plugs

Full Range of Normaling Options

- No normals (requires looping plugs or cords for patch)
- Normals strapped (fully normalled)
- Half-normalled (monitor top row)
- Normals brought out
- Sleeve normals brought out
- Sleeves strapped
- Bussed grounds



**2 RU Longframe 2x24 EDAC 3-Pin
(rear view)**
(PPA3-14MKIV3ENS)



**1 RU Longframe Evenly Spaced 2x24 QCPII
(rear view)**
(PPA1-14MKIINS)

Jacks

The quality of an audio jack is visible in the details. For example, inside ADC's jacks, the gold, self-cleaning crossbar contacts are designed to wipe across each other at an angle that removes debris with every plug insertion. Extended spring beams provide greater resilience for long life and firm contact force. Precision-molded insulators do not change dimensions even in tough environments, ensuring consistent spring torque and reliable performance.

Features

- Jacks used in all patch cords are WECCO-standard jacks that adhere to MIL-STD-202F specifications
- Absolutely reliable WECCO alloy #1 gold, self-cleaning crossbar contacts wipe away debris with every insertion
- Solder-free wire-wrap tails prevent intermittents from cold solder joints or flux migration. Far more reliable than solder
- Tested to withstand tough mobile applications, including vibration, temperature (-55° C to 85° C), moisture, and salt air

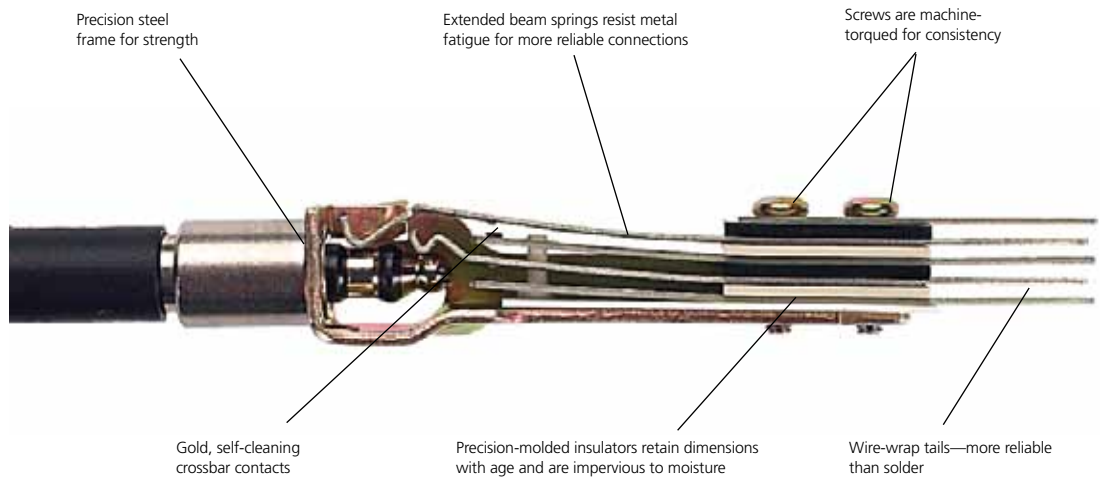

Longframe Audio Jack
(PJ339W)

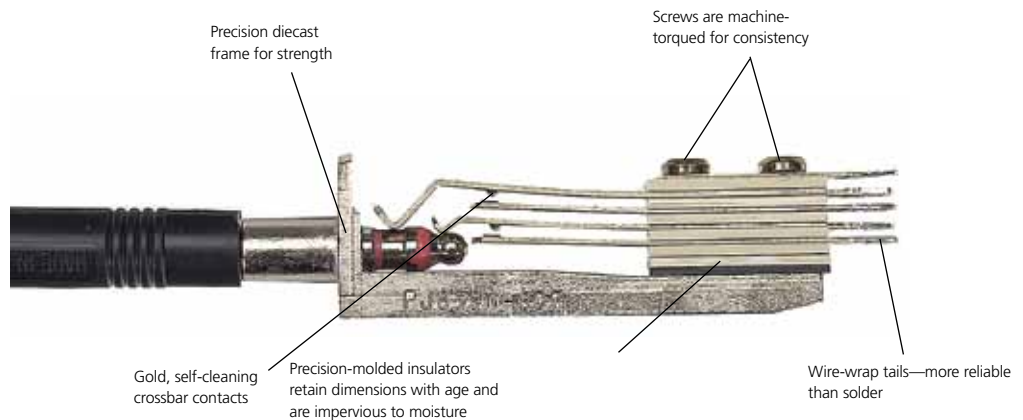

Bantam Audio Jack
(PJ839W)

QCP II and QCP IV Termination Systems

Innovative QCP connectors can really speed up an installation. No need to spend time prepping wires and laboriously soldering and crimping connector pins. Just insert the wire and punch. In one motion you have a reliable gastight connection, even with multiple wires. The unique patented design holds wire far more securely than telco-type punchdowns, preventing intermittents.

MKII panels use QCP II individual terminal insulators, which allow greater density and can be replaced individually. MKIV panels use QCP IV 1x8 terminal blocks insulated on both the front and back of the panel to prevent shorts.



QCP IV Connections

Features

- ADC's exclusive, patented QCP II and QCP IV split-cylinder punchdown termination system is faster and easier to install and more reliable than any other termination system, including solder.
- Dependable, durable, split-cylinder design holds up to three stranded or solid wires, 22 to 26 gauge (0.32 mm to 0.128 mm)
- No intermittents with gastight connections. Uniform split channel width holds each wire firmly, unlike telco punchdowns with V-shaped channels or soldered connections that use flux and may have unreliable solder joints
- Easy pre-lacing makes installation faster. Color-coding prevents wiring mistakes
- Labor-saving punch terminates and cuts wire in one simple motion. QCP IV installs even faster because you don't have to orient the tool before punching
- Faster and easier changes in circuits or normals than soldered connector systems. Rated for up to 200 insertion/withdrawal cycles
- QCP II terminations are individually mounted and insulated for easy repair or replacement
- QCP IV terminations are mounted in 1x8 blocks insulated on both sides of the panel. This design, plus the recessed conductors, eliminates shorts



Audio Patching Systems

ProPatch® Professional (PPA and PPB) Series

7/12 • 108943AE Broadcast and Entertainment Products

Ordering Information

Description	Catalog Number
Patchbays	
Normals Out	
1.75" 2x24 longframe, QCP II, 14" chassis *	PPA1-14MKIINO
3.50" 2x24 longframe, QCP IV, 14" chassis	PPA3-14MKIVNO
3.50" 2x24 longframe, QCP IV, 18" chassis	PPA3-18MKIVNO
3.50" 2x48 bantam, QCP II, 14" chassis	PPB3-14MKIINO
3.50" 2x48 bantam, QCP II, 18" chassis	PPB3-18MKIINO
3.50" 2x48 bantam, QCP II, bussed grounds, 14" chassis	PPB3-14MKIINOBG
Normals Strapped (Fully Normalled)	
1.75" 2x24 longframe, QCP IV, 14" chassis	PPA1-14MKIVNS
3.50" 2x24 longframe, QCP IV, 14" chassis	PPA3-14MKIVNS
3.50" 2x24 longframe, QCP IV, 18" chassis	PPA3-18MKIVNS
3.50" 2x48 bantam, QCP IV, 14" chassis	PPB3-14MKIVNS
1.75" 2x48 bantam, EDAC 90-pin plug, 14" chassis	PPB1-14MKIENS
3.50" 2x48 bantam, EDAC 90-pin plug, 14" chassis	PPB3-14MKIENS
Half-Normals (Monitor top row)	
1.75" 2x24 longframe, QCP IV, 14" chassis	PPA1-14MKIVHN
1.75" 2x24 longframe, EDAC 90-pin plug, 14" chassis	PPA1-14MKII24EHN
3.50" 2x24 longframe, QCP IV, 14" chassis	PPA3-14MKIVHN
3.50" 2x24 longframe, QCP IV, 18" chassis	PPA3-18MKIVHN
1.75" 2x48 bantam, EDAC 90-pin plug, 14" MKII style chassis	PPB1-14MKIIEHN
3.50" 2x48 bantam, QCP IV, 14" chassis	PPB3-14MKIVHN
3.50" 2x48 bantam, EDAC 90-pin plug, 14" chassis	PPB3-14MKIIEHN
No Normals (Requires looping plug or patch cord)	
1.75" 2x24 longframe, QCP IV, 14" chassis	PPA1-14MKIVNN
3.50" 2x48 bantam, QCP IV, 14" chassis	PPB3-14MKIVNN
Sleeve Normals Brought Out	
3.50" 2x24 longframe, QCP IV, 14" chassis	PPA3-14MKIVSN

* 1 RU 2x24 normals out panel only available in QCP MKII version.

** 2x26 panels only available in QCP MKII versions.

For mobile applications, rear chassis support is recommended. Order ProPatch support bar kit (Catalog Number: SBK-1 or SBK-2); mounts on rear rack rails to support rear of panel.

Note: Bussed ground option available on all panels; please contact ADC for details.

Jackfields

ADC broadcast jackfields simplify the task of wiring rack-mounted panels by separating the jacks from the backplane. The jack panel mounts on the front of the rack, and the Ultra Patch termination panel mounts on the rear with an umbilical connecting the two. This arrangement makes the termination wiring more accessible so you don't have to reach into the rack to make connections. In addition, the totally solderless wiring of both panels provides more reliable connections than solder, ensuring dependable service.

Options available include panel sizes, longframe or Bantam jacks, choice of normalizing, standard or custom umbilical length, and QCP II, QCP IV, or EDAC rear panel connectors. All BJF series panels now feature AES digital/audio with precision 110 Ω low capacitance shielded twisted pair cable. MKII panels include fixed cable trays. MKIV panels have adjustable cable bars and white backplanes for better visibility.

Features

Choice of Panel and Umbilical Sizes

- 1 RU jack panel (1.75"/44 mm) with 2 RU (3.5"/88 mm) or 3 RU (5.25"/132 mm) Ultra Patch termination panel
- 2 RU jack panel (3.5"/88 mm) with 3 RU (5.25"/132 mm) Ultra Patch termination panel
- Standard 4-foot (1.2 meter) umbilical or custom lengths available

Longframe or Bantam Jacks

- Longframe jacks in 2x24 or 2x26 array evenly spaced
- Bantam jacks in 2x48 array evenly spaced

Digital Audio Cable

- Precision 110 Ω digital audio cable meets and exceeds stringent AES requirements

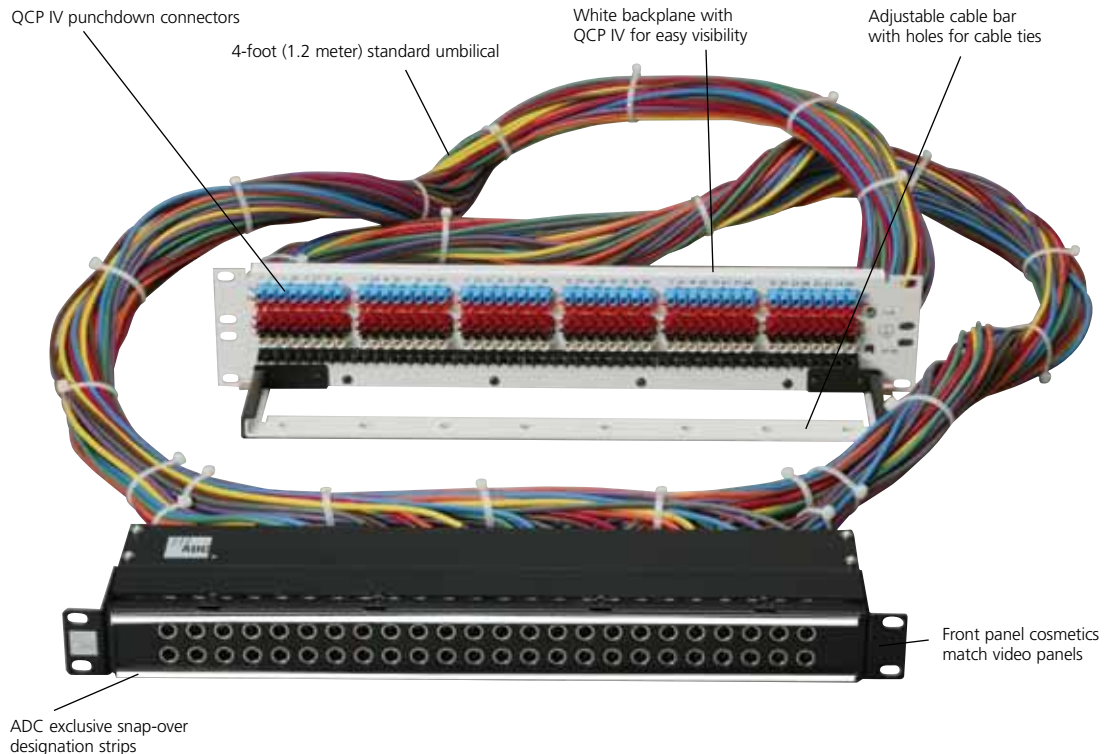

1 RU Longframe/QCP IV Jackfield
(BJF103-4MKIV)

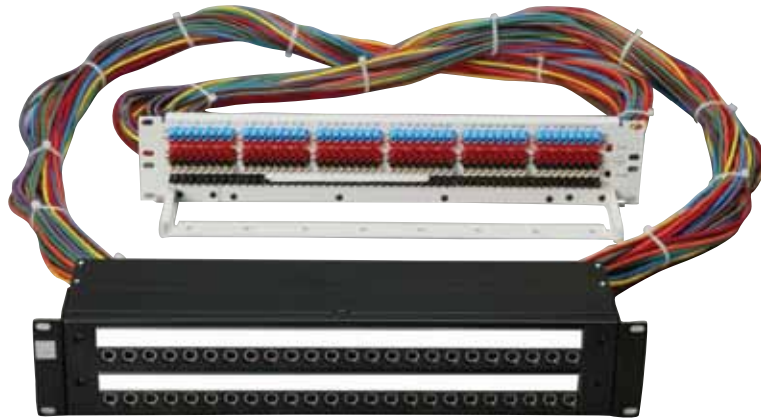

2 RU Longframe/QCP II Ultra Patch
(BJF203-4MKIV)

Options

Choice of Terminations

- QCP II or QCP IV punchdown connectors
- Stub end cut to length
- Adjustable strain relief cable bar included standard on Ultra Patch MKIV. Fixed tray on MKII

Full Range of Normaling Options

- No normals
- Normals strapped (fully normalled)
- Half-normalled (monitor top row)
- Normals brought out
- Sleeve normals brought out
- Sleeves strapped
- Bussed grounds

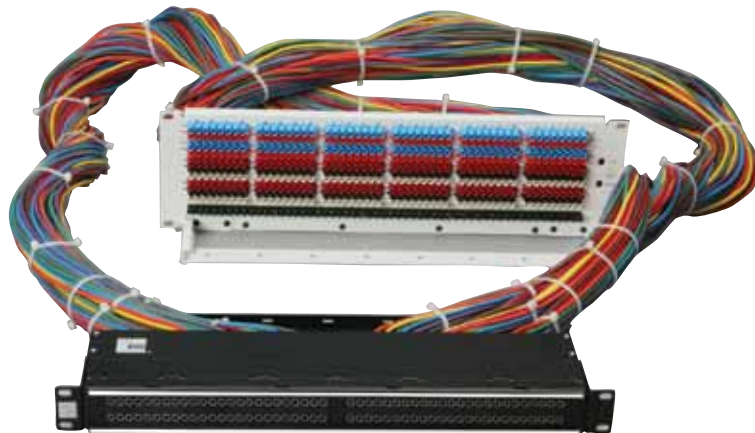

1 RU Bantam/QCP IV Ultra Patch
(BJF303-4MKIV)



Audio Patching Systems

ProPatch® Umbilical (BJF) Series

7/12 • 108943AE Broadcast and Entertainment Products

Ordering Information

Description	Catalog Number
Jackfields*	
Normals Out	
1.75" 2x24 longframe, 4' umbilical, 3.5" QCP IV Ultra Patch	BJF103-4MKIV
3.50" 2x24 longframe, 4' umbilical, 3.5" QCP IV Ultra Patch	BJF203-4MKIV
1.75" 2x48 bantam, 4' umbilical, 5.25" QCP IV Ultra Patch	BJF303-4MKIV
3.50" 2x48 bantam, 4' umbilical, 5.25" QCP IV Ultra Patch	BJF403-4MKIV
Normals Strapped (Fully normalled)	
1.75" 2x24 longframe, 4' umbilical, 3.5" QCP IV Ultra Patch	BJF107-4MKIV
3.50" 2x24 longframe, 4' umbilical, 3.5" QCP IV Ultra Patch	BJF207-4MKIV
1.75" 2x48 bantam, 4' umbilical, 3.5" QCP IV Ultra Patch	BJF307-4MKIV
3.50" 2x48 bantam, 4' umbilical, 3.5" QCP IV Ultra Patch	BJF407-4MKIV
Half-Normals (Monitor top row)	
3.50" 2x24 longframe, 4' umbilical, 3.5" QCP IV Ultra Patch	BJF207-4MKIVHN
1.75" 2x24 longframe, 4' umbilical, 3.5" QCP IV Ultra Patch	BJF107-4MKIVHN
1.75" 2x48 bantam, 4' umbilical, 3.5" QCP IV Ultra Patch	BJF307-4MKIVHN
3.50" 2x48 bantam, 4' umbilical, 3.5" QCP IV Ultra Patch	BJF407-4MKIVHN
No Normals (Requires looping plug or patch cord)	
3.50" 2x48 bantam, 4' umbilical, 3.5" QCP IV Ultra Patch	BJF407-4MKIVNN
Sleeve Normals Brought Out	
3.50" 2x24 longframe, 4' umbilical, 3.5" QCP IV Ultra Patch*	BJF203-4MKIVSN
3.50" 2x48 bantam, 4' umbilical, 5.25" QCP IV Ultra Patch	BJF403-4MKIVSN

* 2x26 panels only available in QCP MKII versions.
 Custom panel configurations are available; please contact ADC.

Solder-Style Panels

ProPatch® Lite is ADC's line of low-cost, do-it-yourself audio patchbays. For ADC quality on a budget, this is the answer. Features include a steel frame with sturdy molded insert for holding jacks, a removable steel strain relief cable bar, ADC's outstanding quality WECO-standard bantam or longframe jacks with solder tails ready to wire, and choice of normalling configurations. Models are available in Bantam and Longframe jacks, in one and two rack unit heights with designation strips and standard jack spacing.

Features

Sturdy Construction

- Steel frame with durable molded insert for holding jacks
- Removable steel cable bar

Two Panel Sizes

- 1 RU (1.75"/44 mm)
- 2 RU (3.5"/88 mm)

Longframe or Bantam Jacks

- Longframe jacks, 2x24 or 2x26 array, WECO-standard with solder tails ready for wiring
- Bantam jacks, 2x48 array, WECO-standard with solder tails ready for wiring
- Several ground lug styles

Choice of Normals

- Normals out
- Pre-half-normalled, common ground
- Pre-normals strapped, common ground
- Sleeve normal



Durable cable bar with large holes for cable wraps

Offset lugs for common ground

Durable molded inserts

**1RU Stereo-Spaced Longframe 2x24 Panel
(rear view)
(PPA1)**

Ordering Information

Ordering Information	
Description	Catalog Number
Longframe Panels	
1.75" 2x24 longframe jacks with solder lugs, loaded with 48 PJ339 jacks (see page 61)	PPA1
Half-normalled, common ground	PPA1-HN-CG
Normals strapped, common ground	PPA1-NS-CG
1.75" 2x24 longframe solder jacks with offset ground lugs	PPA1-L204
3.5" 2x24 longframe jacks with solder lugs, loaded with 48 PJ339 jacks (see page 61)	PPA3
Half-normalled, common ground	PPA3-HN-CG
Normals strapped, common ground	PPA3-NS-CG
Bantam Panels	
1.75" 2x48 bantam jacks with solder lugs, loaded with 96 PJ839 jacks (see page 61)	PPB1
Half-normalled, common ground	PPB1-HN-CG
Normals strapped, common ground	PPB1-NS-CG
3.5" 2x48 bantam jacks with solder lugs, loaded with 96 PJ839 jacks (see page 61)	PPB3
Half-normalled, common ground	PPB3-HN-CG
Normals strapped, common ground	PPB3-NS-CG
3.5" 2x48 bantam jacks with solder lugs, sleeve normals, loaded with 96 PJ824 jacks	PPB3-SN

For information on this and other custom configurations, please contact ADC.



1 RU Stereo-Spaced Bantam 2x48 Panel
(PPB1)



1 RU Longframe 2x24 Panel
(PPA1-24-NS-CG)

Whatever the accessory you need for your audio patchbay, the quality source is ADC. Products available include patch cords, connectors and jacks, designation strip kits, and more.

High-Performance Audio Patch Cords

ProPatch audio patch cords are engineered for flawless performance and durability. Nickel plating protects plugs against corrosion and ensures smooth insertion, and the exclusive dielectric compound between conductors provides low capacitance for the best signal performance. The flexible cord drapes neatly without kinking, and the plug is molded directly onto the cord for outstanding strain relief.



All ADC patch cords are designed to meet MIL-P642 and are machined after molding for perfect concentricity, ensuring consistent, reliable jack operation.

Features

- Meets demanding MIL-J641 and MIL-P642 standards for plug compliance
- Precision WECO 310 (longframe) and bantam plugs assure proper jack performance
- Quad-star construction for low noise performance
- Models for analog or digital audio
- Standard lengths from .6 m (2 feet) to 1.8 m (6 feet). Other lengths available on request
- Colors include red, green, blue, or black. Some cords also available in yellow or gray
- Conversion patch cords for RS-422 to RJ45. (Conversion patch cords for longframe to bantam, single to dual, are also available. Please contact ADC.)

Catalog Number

Color

R	Red
G	Green
B	Blue
Y	Yellow*
BK	Black
GY	Gray*

DA	Digital audio (black only)
----	----------------------------

Cable Length

LEAVE BLANK	Longframe plug
B	Bantam plug

Cable Length

2	.6 m (2')
3	.9 m (3')
4	1.2 m (4')
6	1.8 m (6')

* Non-standard colors. Please contact ADC for these and other non-standard colors.

Dual patch cords are available. Add a "2" after length. For example, R22 = Red (2') dual longframe
R22B = Red (2') dual bantam

Individual longframe and bantam plugs are available featuring low capacitance injection-molded insulators and precision-machined brass or nickel-plated conductors for smooth insertion and best signal performance. Wire connections are made via miniature screw terminals. These plugs provide the best fit and performance to match ADC patch panels.

Longframe Audio Plugs

Ordering Information

Description	Color	Catalog Number
Three-Conductor Longframe Plugs (field installable)		
Single	Red	PJ051R
Single	Black	PJ051B
Single, nickel-plated	Black	PJ051B-MN
Looping Plugs – internal connections tie together corresponding tip, ring and sleeve conductors to allow looping of jack circuits	Black	PJ4
Hole Plugs – for longframe panels to fill unused jack positions	Black	PJ29

Bantam Audio Plugs

Ordering Information

Description	Color	Catalog Number
Three-Conductor Bantam Plugs		
Single plug; attachable plug; two lugs, shell mounting screw and two lug attachment screws supplied	Red	PJ777R
	Black	PJ777B
Dual plug; attachable plug; four lugs, two shell mounting screws and four lug attachment screws supplied	Black	PJ778B
Looping Plugs – Used to “loop” or patch adjacent jack circuits; plug conductors strapped internally; wired tip to tip, ring to ring and sleeve to sleeve	Black	PJ746
Hole Plugs – For bantam panels to fill unused jack positions	Red	PJ729R
	Black	PJ729B
Single Bantam Circuit Guard Plugs – To identify or block entry to critical circuits; does not actuate circuit	Red	PJ925R
	White	PJ925W
	Black	PJ925B

Longframe and Bantam Audio Jacks

If anything differentiates ADC patching products from the competition it is the outstanding quality of our jacks. Consistent quality and durability are built into every jack we make. Our jacks meet WECCO and MIL-STD-202F standards and include gold, self-cleaning contacts, extended spring beams to prevent metal fatigue and poor contact, and precision-molded insulators.

PJ339 Single Longframe Jack (2 normally closed contacts)

The PJ339 is a three-conductor, single, longframe jack with two normally closed contacts and solder tails. PJ339L has offset solder tails, and PJ339W is the wire-wrap version.



Longframe Audio Jack
(PJ339W)

PJ242 Single Longframe Jack (3 normally closed contacts)

The PJ242 is a three-conductor, single, longframe jack with three normally closed contacts and solder tails. PJ242W is the wire-wrap version.

PJ839 Single Bantam Jack (2 normally closed contacts)

The PJ839 is a three-conductor, single, bantam jack with two normally closed contacts. The PJ839N-SDR comes with solder tails, and the PJ839WN is the wire-wrap version.



Bantam Audio Jack
Shown with Plug Inserted
(PJ839W)

PJ824 Single Bantam Jack (3 normally closed contacts)

The PJ824 is a three-conductor, single, bantam jack with three normally closed contacts. The PJ824N comes with solder tails, and the PJ824WN is the wire-wrap version. (Note that if stacked, these jacks extend beyond the periphery of a 1.75" 1 RU panel.)



Audio Patching Systems

Accessories

Longframe and Bantam Audio Jacks

Ordering Information

Description	Catalog Number
Longframe Jacks	
3-conductor – 2 normally closed contacts, solder tails, frame style A, stack height .531" (13.49 mm), WECO 239A equivalent	PJ339
3-conductor – 2 normally closed contacts, solder offset lug, frame style A, stack height .531" (13.49 mm)	PJ339L
3-conductor – 2 normally closed contacts, wire-wrap, frame style A, stack height .578" (14.68 mm)	PJ339W
3-conductor – 3 normally closed contacts, solder tails, frame style C, stack height .687" (17.45 mm), WECO 242C equivalent	PJ242
3-conductor – 3 normally closed contacts, wire-wrap, frame style C, stack height .687" (17.45 mm), WECO 242C equivalent	PJ242W
Bantam Jacks	
3-conductor – Rear-mount bantam jack, 2 normally closed contacts, solder tails, stack height .602" (15.29 mm)	PJ839N-SDR
3-conductor – Rear-mount bantam jack, 3 normally closed contacts, solder tails, stack height .756" (19.20 mm)	PJ824N
3-conductor – Rear-mount bantam jack, 3 normally closed contacts, wire-wrap, stack height .750" (19.05 mm)	PJ824WN

7/12 • 108943AE Broadcast and Entertainment Products

Audio Baluns

High-quality audio baluns are available for 110 Ω twisted pair to 75 Ω coaxial matching. Matches BNC to male or female XLR connectors.



Shown: BAL-XLR-BNC-F
BAL-XLR-BNC-M

Designation Strip Kits

ADC produces designation strip kits for all of our patch panels. For details about kits available for your particular model, please contact the Technical Assistance Center.

QCP and EDAC Tools and Accessories

(Genuine EDAC, manufactured in North America)

Individual punchdown tools and complete tool kits are available for both QCP II and QCP IV connections. The same punchdown tool works for both types, but the tips are different. EDAC connector kits are also available for E120, E90, E56, E38 and E3 connectors—genuine EDAC parts.



LSA-PLUS® Punchdown Tool



EDAC
90-shell Kit



EDAC
38-shell Kit



EDAC
Crimp Tool



QB-2



SLVG-1



QRK-25

ProPatch Cord Holder

The ProPatch cord holder accepts up to 75 video or audio patch cords and mounts on the wall or in a rack. (Note: does not hold CVPC-type patch cords.)



Patch Cord Holder
(PPH)

Ordering Information

Description	Catalog Number
Audio Baluns, 110 Ω to 75 Ω	
BNC to female XLR	BAL-XLR-BNC-F
BNC to male XLR	BAL-XLR-BNC-M
LSA-Plus Punchdown Tool	DM-GIGE-TOOL-KIT
QCP Tools	
Impact tool for MKII panels, with tip*	QB-2
Tool for MKIV panels, with tip*	QB-4
Replacement tip for QB-2	QB-2T
Longer replacement tip for QB-2	QB-2LT
Replacement tip for QB-4	QB-4T
Replacement tip for QB4, long	QB-4LT
QCP Mark II Replacement Kit; Kit includes instructions and the following: 99 QCP contacts, 25 red, black and white insulators, 12 blue and orange insulators	QRK-25
QCP Mark IV Replacement Kit; 2 red, white, black, blue and orange QCP IV (8x1) punchdown assemblies	QRK-25-MKIV
Sleeving Kit; Kit includes 100 pieces of 2.5" (6.35 cm) clear PVC	SLVG-1
EDAC Tools (Manufactured by Paladin)	
Tool for crimping EDAC connector pins	EDAC-CRIMP-TOOL
EDAC pin removal tool	EDAC-EXTRACTION-TOOL
Receptacle Connector Kits (Manufactured by EDAC)	
Kit for EDAC 90-pin, includes 1 shell, 90 crimp-type pins, and hood	EDAC-90P-SHELL
Kit for EDAC 3-pin, includes 1 shell and 3 crimp-type pins	EDAC-3P-SHELL
Kit for EDAC 3-pin, complete for 2x24 panel	EDAC-3PIN-2X24-KIT
Kit for EDAC 3-pin, complete for 2x32 panel	EDAC-3PIN-2X32-KIT
Kit for EDAC 3-pin, complete for 2x48 panel	EDAC-3PIN-2X48-KIT
ProPatch® Cord Holder; Holds up to 75 video or audio patch cords (bantam or longframe); mounts on a wall or in a rack; 14"W x 3"D (35.56 x 7.62 cm). Note: does not hold CVPC-type patch cords	PPH

* QCP II and QCP IV tools are identical but the replaceable tips are different.

BROADCAST AND ENTERTAINMENT PRODUCTS

Tyco Electronics and ADC are now **TE Connectivity**



Website: www.te.com

From North America, Call Toll Free: 1-800-366-3891 • Outside of North America: +1-952-938-8080

Fax: +1-952-917-3237 • For a listing of TE's global sales office locations, please refer to our website.

TE Connectivity, P.O. Box 1101, Minneapolis, Minnesota USA 55440-1101

Specifications published here are current as of the date of publication of this document. Because we are continuously improving our products, TE reserves the right to change specifications without prior notice. At any time, you may verify product specifications by contacting our headquarters office in Minneapolis. TE Connectivity views its patent portfolio as an important corporate asset and vigorously enforces its patents. Products or features contained herein may be covered by one or more U.S. or foreign patents. An Equal Opportunity Employer

108943AE 7/12 Revision © 2012, 2010 TE Connectivity All Rights Reserved