



Product Catalogue

Providing Protection for
Automotive Wiring Harnesses

Welcome to Thomas & Betts

At Thomas & Betts, our focus is on improving your business performance by providing practical, reliable electrical products & services. To connect & protect for life. To solve everyday problems in the area's of Wire & Cable Management, Cable Protection, Power Connection & Control and Safety. Our extensive engineering, supply chain management and technical sales support teams are committed to understanding everything that impacts your ability to accomplish your business objectives by reducing your total cost of ownership.

Whether you are designing, installing, operating, maintaining or owning an office building, off-shore platform, hospital, or a high speed train, power generating plant, machine equipment, manufacturing or automotive production facility, Thomas & Betts engineered products fit and function in your application while providing superior performance, sustainability, and value throughout the project life cycle.

All our brands are built upon four product & service solution platforms. Platforms that address you or your customers' critical electrical & lighting needs covering the protection of data, energy, processes, assets and personal safety. Beyond hi-performance application characteristics, Thomas & Betts products, information and services facilitate and speed up your time critical assembly, installation or maintenance process.



Contents

Conduit	4 - 14	Sealed Fittings	47 - 63
NC	6 - 7	Straights	48 - 49
CTPA	8 - 9	Elbows	50 - 51
HNC	10	90° flanges	52
CPC	11	T-Pieces	53
PP/DSPP	12 - 13	X Pieces	54
PKC	14	Manifolds	55
HTC	14	Circular UNEF Connector Interfaces	56
		Solenoid Connector Interfaces	57
Hinged fittings	15 - 34	Reducing Bushes	58
Hinged Joiners	16	Cable Glands	59
Hinged Elbows	17	Accessories	60 - 61
T Pieces	18 - 19	Clips	62 - 63
Y Pieces	20 - 21		
Shrouds	22	Technical	64 - 69
X Pieces	23		
Custom Hinged Manifolds	24		
Split Manifolds	25		
Circular Manifolds	26		
Interfaces	27 - 46		
Amp Superseal	28		
Amp Junior & Mini Timer	29		
Ampseal	30 - 31		
Deutsch DT	32 - 33		
Deutsch DTP04	34		
Deutsch DRC50	35		
FCI Apex	36		
Bosch compact	37		
Delphi Series	38 - 39		
Molex MX93286 Series	40 - 41		
Kostal	42		
Milflex ABS	43		
Sumito	43		
DIN 72585	44		
Circular Connectors	45		
Accessories	46		



Selection Table for Conduit

		Conduits							
		NC (Polyamide 6)	CTPA (Polyamide 6)	HNC (Polyamide 12)	CPC (FR Co-polyester)	PP (Polypropylene)	DSPP (Modified Polypropylene)	PKC (Polyetheretherketone)	HTC (Modified Nylon)
Catalogue Page Number		6	8	10	11	12	12	13	14
Long Term Static temp. (°C) Min		-40	-40	-50	-45	-20	-20	-60	-45
Long Term Static temp. (°C) Max		120	120	110	135	90	90	260	200
UV Resistance		■■■■	■■■■	■■■■	■■■■	■■□□	■■■□	■■■■	■■■■
Flexibility		■■■□	■■■□	■■■■	■■■□	■■■■	■■■□	■■■■	■■□□*
Fatigue Life		■■■□	■■■□	■■■■	■■■□	■■■■	■■■■	■■■□	■■□□*
Halogen Free		●	●	●	●	●	●	●	
Self Extinguishing		●	●	●	●	-	●	●	●
External Wear Resistance		■■■■	■■□□	■■■□	■■■□	■■□□	■■■□	■■■■	■■■■
Slit version available		●	●	-	-	-	Slit only	-	-
Chemical Resistance	IRM 903 (ASTM Oil No.2)	S	S	S	S	S	S	S	S
	Diesel Oil	S	S	S	S	S	S	S	S
	Ethylene Glycol (Anti-freeze)	S	S	S	S	S	S	S	S
	Lubricating Oil	S	S	S	S	S	S	S	S
	Methyl Alcohol	L	L	S	S	S	S	S	S
	Parafin Oil	S	S	S	S	S	S	S	S
	Petrol	S	S	S	S	S	S	S	S
	Sodium Chloride	S	S	S	S	S	S	S	S
	Sodium Hydroxide (10%)	S	S	S	S	S	S	S	S
	Transformer Oil	S	S	S	S	S	S	S	S
	Urea	S	S	S	NT	NT	NT	S	S
	Vegetable Oil	S	S	S	S	S	S	S	S
Sea (Water)	S	S	S	S	S	S	S	S	

Key: S = Suitable, L = Limited Suitability, U = Unsustainable, NT = Not Tested. All chemicals tested for resistance at 33°C.
Maximum Performance = ■■■■

Design Interaction

Ingress Protection (I.P.) ratings

Harnessflex hinged systems are rated at IP40. Harnessflex sealed systems are rated at IP66, 67, 68 (2 BAR for 30mins) & 69k. Only when using Harnessflex conduit.

Product Specifications

All Harnessflex fittings are manufactured from Polyamide 6,6 (PA 6,6) and are black in colour. Other colours and materials can be made available to achieve specific customer requirements. Product datasheets and dimension charts are available for the full Harnessflex range - please submit your request via our website or call the Harnessflex technical support desk.

Design Data

Harnessflex parts are developed in house using the following CAD systems:

- AutoDesk Inventor
- AutoDesk AutoCAD

Drawing files are available in the following CAD formats (as well as the versatile PDF format):
DWG, DXF, DWF, IGES, STEP, STL, PRT, ASM, IPT, IAM.

Pre-production Samples

From CAD data we are able to produce accurate representations of final manufactured products, using a 3D printing process. Prototype fittings are typically produced in Duraform PA, a material that gives similar performance in tests to PA 6,6. Prototype extrusions can be manufactured in a variety of materials (please contact us for details). This process allows a product design to be validated before the part is tooled for manufacture.

Technical Support

Worldwide sales support via our experienced engineers. Please contact us to discuss any of our products, or the possibility of developing a solution specific to your needs.



NC Standard Weight, Polyamide 6 General Purpose Conduit

Description

Flexible standard weight nylon (PA6) conduit is a general-purpose conduit suitable for automotive harness applications. It can withstand extremes of temperatures and resists automotive oils and solvents. It is extremely tough and has a high impact strength and fatigue life.

Solid NC conduits provide protection against mechanical shock and ingress of water whilst maintaining their form through tight bend radii.

ADR approved for hazardous vehicles.

Applications

NC standard weight is extensively used in harnesses on HGV, off road vehicles and marine applications where a superior protection against impact and mechanical shock is preferred. The conduit is used for both chassis and engine applications and can be used in a wide range of temperatures. Polyamide 6 is highly resistant to all hydrocarbon based oils and fluids and many types of solvents.

NC is designed for connection to all Harnessflex sealed and hinged system fittings

NC conduits are available in a range of popular sizes. The standard colour is black with other colours including orange for hybrid vehicles also being available on request.

NC conduit configurations and dimensions

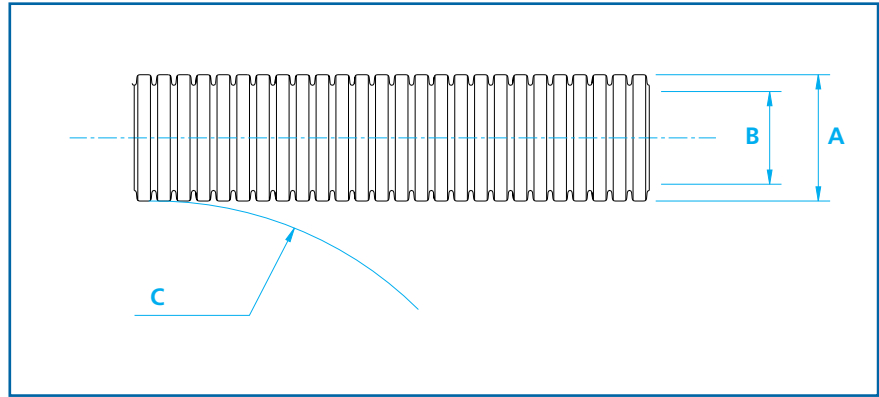

Configuration/nominal dimensions/part numbers

Part Number	Conduit Size		Nominal O/D	Min Bore	Min Static Bend Rad.	Length (m)
	(NC)	NW	A	B	B	
NC06	06	4.5	7.1	4.5	5	100
NC08	08	7.5	10.0	6.5	15	100
NC10	10	8.5	11.5	8.4	15	100
NC12	12	10	13.0	9.9	20	100
NC16	16	13	16.0	11.8	30	100
NC20	20	17	21.2	16.6	35	50
NC25	25	22	25.6	21.3	40	50
NC28	28	23	28.5	22.6	45	50
NC30	30	26	31.6	26.0	50	50
NC32	32	29	34.5	28.8	55	50
NC40	40	36	42.5	34.8	65	25
NC50	50	48	54.5	46.9	70	25

- To order, quote part number and reel length.

- For colours other than standard black also add colour, ie for orange IOR, IRD for red conduit.

** NOTE: dimensions are in mm.

NC Slit Standard Weight, Polyamide 6 General Purpose Conduit

NC Slit conduit configurations and dimensions

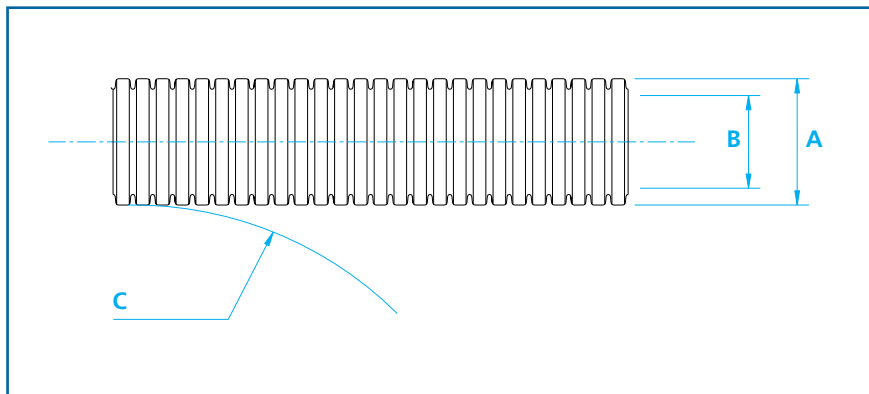

Hints & Tips

Kwikcut is the ideal cutting tool for all non-metallic conduits upto 32mm.

Cutting Instructions

Place the conduit between the cutting blade and lower support, squeeze the handles and rotate the conduit for a clean, easy cut. Spare blades are available.

Part Numbers

- Kwikcut
- Kwikcut-Blade

Configuration/nominal dimensions/part numbers

Part Number	Conduit Size		Nominal O/D	Min Bore	Min Static Bend Rad.	Length (m)
	(NC)	NW	A	B	B	
NC06-S	06	4.5	7.1	4.5	5	100
NC08-S	08	7.5	10.0	6.5	15	100
NC10-S	10	8.5	11.5	8.4	15	100
NC12-S	12	10	13.0	9.9	20	100
NC16-S	16	13	16.0	11.8	30	100
NC20-S	20	17	21.2	16.6	35	50
NC25-S	25	22	25.6	21.3	40	50
NC28-S	28	23	28.5	22.6	45	50
NC30-S	30	26	31.6	26.0	50	50
NC32-S	32	29	34.5	28.8	55	50
NC40-S	40	36	42.5	34.8	65	25
NC50-S	50	48	54.5	46.9	70	25

- To order, quote part number and reel length.

- For colours other than standard black also add colour, ie for orange IOR, IRD for red conduit.

** NOTE: dimensions are in mm.

1 Durable construction

Providing enhanced resistance to compression and impact forces

2 PA6 material

Providing fire retardant properties, halogen free and low smoke emissions

3 Harsh environment capability

Providing a wide operating temperature range



CTPA, Lightweight, Polyamide 6 Flexible Conduit

Description

Flexible lightweight nylon (PA6) conduit is a general-purpose conduit suitable for automotive harness applications. It can withstand extremes of temperatures and resists automotive oils and solvents. It is extremely tough and has a high impact strength and fatigue life.

CTPA conduits provide protection against mechanical shock and ingress of water whilst maintaining their form through tight bend radii.

Applications

Lightweight convoluted tube used for interior harnesses offering limited mechanical protection to provide abrasion resistance and enhance the aesthetics of the harness.

- Extremely light and flexible.
- Resistant to oils and solvents.

CTPA conduit configurations and dimensions

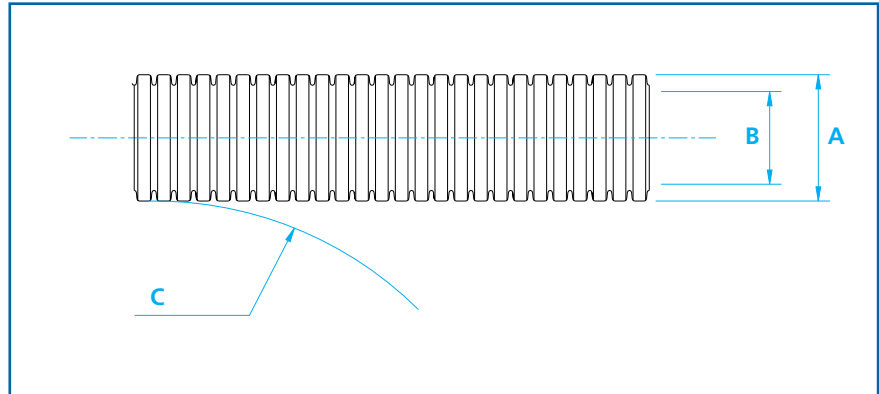

Configuration/nominal dimensions/part numbers

Part Number	Conduit Size		Nominal O/D	Min Bore	Min Static Bend Rad.	Length (m)
	(NC)	NW	A	B	B	
CTPA08	08	7.5	10.0	6.5	10	100
CTPA10	10	8.5	11.5	8.7	15	100
CTPA12	12	10	13.0	10.1	20	100
CTPA16	16	13	16.0	11.8	35	100
CTPA20	20	17	21.2	16.9	45	100
CTPA25	25	22	25.6	21.3	45	100
CTPA28	28	23	28.5	23.1	45	100
CTPA30	30	26	31.6	26.0	50	50
CTPA32	32	29	34.5	28.8	55	50
CTPA40	40	36	42.5	35.0	65	25
CTPA50	50	48	54.5	46.0	90	25

- To order, quote part number and reel length.

- For colours other than standard black also add colour, ie for orange IOR, IRD for red conduit.

** NOTE: dimensions are in mm.



1 Lightweight design

Ideal for automotive harness fabrication

2 Enhanced flexibility

Ideal for use in installations where space is limited

3 PA6 material

Providing fire retardant properties and halogen free emissions

CTPA Slit, Lightweight, Polyamide 6 Flexible Conduit

CTPA conduit configurations and dimensions

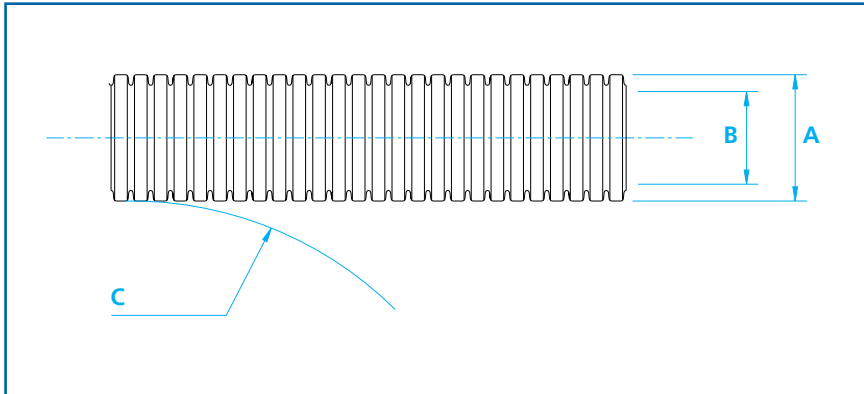

Hints & Tips

Kwikcut is the ideal cutting tool for all non-metallic conduits upto 32mm.

Cutting Instructions

Place the conduit between the cutting blade and lower support, squeeze the handles and rotate the conduit for a clean, easy cut. Spare blades are available.

Part Numbers

- Kwikcut
- Kwikcut-Blade

Configuration/nominal dimensions/part numbers

Part Number	Conduit Size		Nominal O/D	Min Bore	Min Static Bend Rad.	Length (m)
	(NC)	NW	A	B	B	
CTPA08-S	08	7.5	10.0	6.5	10	100
CTPA10-S	10	8.5	11.5	8.7	15	100
CTPA12-S	12	10	13.0	10.1	20	100
CTPA16-S	16	13	16.0	11.8	35	100
CTPA20-S	20	17	21.2	16.9	45	100
CTPA25-S	25	22	25.6	21.3	45	100
CTPA28-S	28	23	28.5	23.1	45	100
CTPA30-S	30	26	31.6	26.0	50	50
CTPA32-S	32	29	34.5	28.8	55	50
CTPA40-S	40	36	42.5	35.0	65	25
CTPA50-S	50	48	54.5	46.0	90	25

- To order, quote part number and reel length.

- For colours other than standard black also add colour, ie for orange IOR, IRD for red conduit.

** NOTE: dimensions are in mm.

1 Lightweight design

Ideal for automotive harness fabrication

2 Enhanced flexibility

Ideal for use in installations where space is limited

3 PA6 material

Providing fire retardant properties and halogen free emissions



HNC Standard Weight, Polyamide 12 Low Temperature, Extra Flexible Conduit

Description

HNC standard weight conduit is made from polyamide 12 and is specially formulated to meet the environmental and mechanical requirements for the exterior of working vehicles.

HNC conduit also provides protection against mechanical shock and ingress of water whilst maintaining its form through tight bend radii. It has been specifically designed to cope with extremes of temperature combined with repeated movement and vibration.

Applications

HNC conduit is particularly used in applications requiring repeated flexing coupled with low temperature impact toughness.

Robotics, rapid or continuous motion applications demanding high fatigue life and extra flexibility are covered by HNC which is also used in low temperature environments.

HNC Standard weight conduit is designed for connection to all Harnessflex hinged and sealed fittings.

Contact us for slit conduit options.

HNC conduit configurations and dimensions

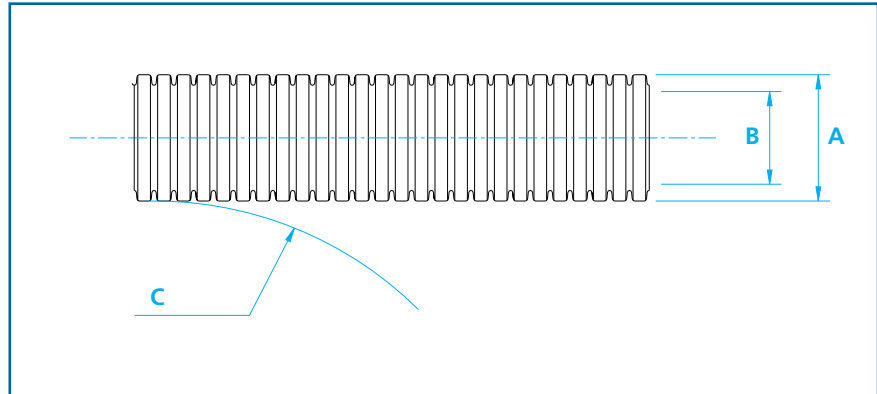

Configuration/nominal dimensions/part numbers

Part Number	Conduit Size		Nominal O/D	Min Bore	Min Static Bend Rad.	Length (m)
	(NC)	NW	A	B	B	
HNC08	08	7.5	10.0	6.2	15	100
HNC12	12	10	13.0	9.9	25	100
HNC16	16	13	15.8	11.7	30	100
HNC20	20	17	21.2	16.6	35	50
HNC25	25	22	25.3	21.0	40	50
HNC28	28	23	28.5	21.7	45	50
HNC32	32	29	34.5	27.7	55	50
HNC40	40	36	42.5	35.5	60	25
HNC50	50	48	54.5	46.6	70	25

*NOTE: dimensions are in mm



1 Harsh environment capability

Providing high performance at extremely low temperatures

2 Enhanced flexibility

Ideal for use in installations where space is limited

3 Durable construction

Providing enhanced resistance to compression and impact forces

4 PA12 material

Providing high impact resistance and very high flexibility at low temperatures.

CPC Medium Weight (FR Co-polyester) Flame Retardant Conduit

CPC conduit configurations and dimensions

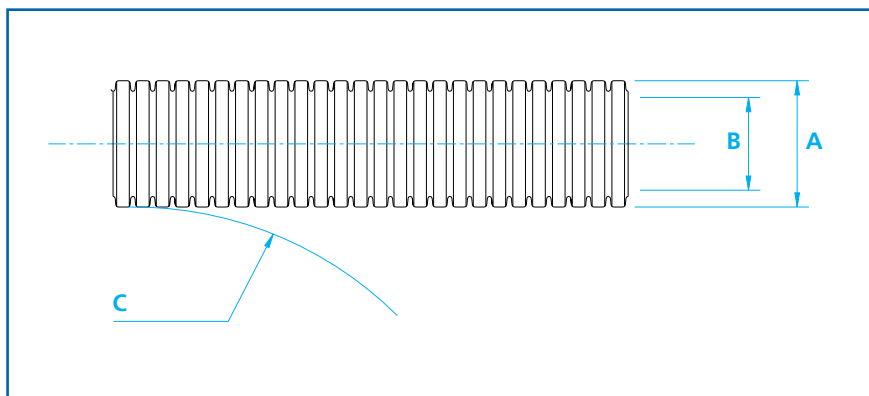

Configuration/nominal dimensions/part numbers

Part Number	Conduit Size		Nominal O/D	Min Bore	Min Static Bend Rad.	Length (m)
	(NC)	NW	A	B	B	
CPC08	08	7.5	9.8	6.2	20	50
CPC12	12	10	13.0	9.4	25	50
CPC16	16	13	16.0	11	30	50
CPC20	20	17	21.2	16.1	40	50
CPC25	25	22	25.3	21.0	45	50
CPC28	28	23	28.5	22.5	45	50
CPC32	32	29	34.5	27.2	55	50
CPC40	40	36	42.5	34.2	60	25
CPC50	50	48	54.1	46.0	70	25

*NOTE: dimensions are in mm



Description

CP standard weight conduit is made from flame retardant co-polyester, which is a halogen free, low smoke and very low toxicity material. It has excellent high and low temperature properties.

CP conduits provide protection against mechanical shock and ingress of water whilst maintaining their form through tight bend radii. This material demonstrates excellent chemical resistance to greases, hydrocarbons, fuels and oils.

Applications

CP is particularly used in applications requiring low fire hazard performance, it is lightweight and retains its flexibility at extremes of temperature. CP is designed for use in the interior and exterior of vehicles and marine passenger cabins.

CP is designed for connection to all Harnessflex Hinged and Sealed fittings.

Contact us for slit options.

Hints & Tips

Kwikcut is the ideal cutting tool for all non-metallic conduits upto 32mm.

Cutting Instructions

Place the conduit between the cutting blade and lower support, squeeze the handles and rotate the conduit for a clean, easy cut. Spare blades are available.

Part Numbers

- Kwikcut
- Kwikcut-Blade

Modified PP Medium Weight Polypropylene Conduit

Modified PP, medium weight Polypropylene conduit

Description

PP is a flexible conduit made from Polypropylene.

PP conduits provide very good acid resistance, they have very good flexibility and a very high fatigue life.

Applications

PP is particularly used in lighter applications where compression strength and LFH is not so important. The main property of this conduit, being acid resistance.

- Halogen free - not self-extinguishing.
- PP conduits are available in a range of popular sizes. The conduit comes in black only.
- PP is designed for connection to all Harnessflex Sealed and Hinged system fittings.

Modified PP conduit configurations and dimensions

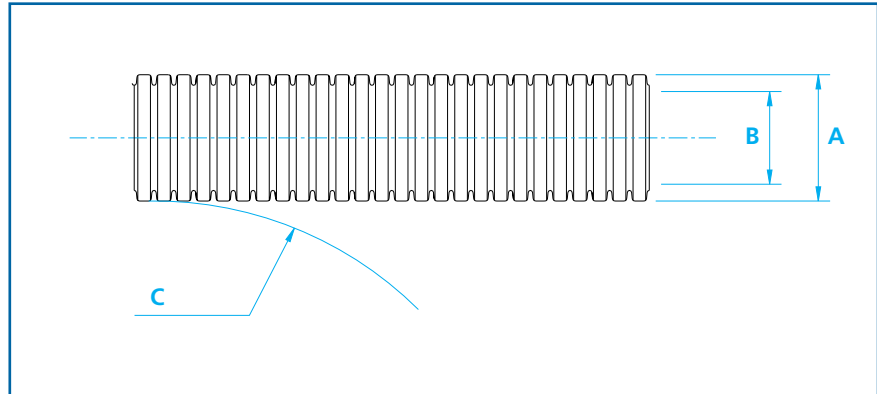

Configuration/nominal dimensions/part numbers

Part Number	Conduit Size		Nominal O/D	Min Bore	Min Static Bend Rad.	Length (m)
	(NC)	NW	A	B	B	
PP08	08	7.5	10.0	6.4	15	100
PP10	10	8.5	11.5	8.6	20	100
PP12	12	10	13.0	9.6	25	50
PP16	16	13	16.2	11.2	35	50
PP20	20	17	21.2	16.9	35	50
PP25	25	22	25.6	21.5	40	50
PP28	28	23	28.5	23.2	45	50
PP32	32	29	34.5	29.1	55	50

*NOTE: dimensions are in mm

**For slit conduit options add -S to part number eg PP08-S/100m



1 Lightweight design

Ideal for automotive harness fabrication

2 Enhanced flexibility

Ideal for use in installations where space is limited

3 Modified PP material

Providing enhanced fire and low temperature impact and chemical resistant properties

Modified Slit PP Deep Section Medium Weight Polypropylene Conduit

Deep Section PP Configuration/nominal dimensions/part numbers

Part Number	Conduit Size		Nominal O/D	Min Bore	Min Static Bend Rad.	Length (m)
	(NC)	NW	A	B	B	
DSPP08	08	7.5	10.0	6.6	10	100
DSPP12	12	10	13.0	8.5	18	100
DSPP16	16	13	16.2	11.1	32	100
DSPP20	20	17	21.2	15.0	40	100
DSPP28	28	23	28.5	21.7	50	100
DSPP32	32	29	34.5	27.7	58	50
DSPP40	40	36	42.5	34.6	80	25
DSPP50	50	48	54.5	46.5	100	25

*NOTE: dimensions are in mm

Deep Section Modified Slit PP Polypropylene, Medium weight conduit

Description

DSPP conduit is made from a flame retarded material. DSPP slit conduits provide protection against mechanical shock whilst maintaining its form through tight bend radii.

Applications

DSPP has a deep section to maintain the conduit shape during bending. Deep Section Conduits are supplied in slit form to facilitate rapid cable installation and are designed for connection to all Harnessflex hinged fittings.

1 Durable construction

Providing enhanced resistance to compression and impact forces

2 Deep section

Prevents slit form from opening when bent around tight radii

3 Modified PP material

Providing enhanced fire and low temperature impact and chemical resistant properties



PKC Standard Weight Polyketone Super Low Fire Hazard Conduit

Description

Super Low Fire Hazard PK is a standard weight conduit, which offers superior mechanical strength as well as high radiation and chemical protection often in extreme temperatures. It is a unique product manufactured from a specialist polymer, for use in the most demanding applications.

Peek is a truly high performance conduit.

Applications

This conduit with its high specification performance is used in some of the most demanding applications for flexible conduit.

It is often found in Aerospace, Off-shore, Military, Heat treatment, Nuclear, Petrochemical and Marine application.

PKC conduit configurations and dimensions

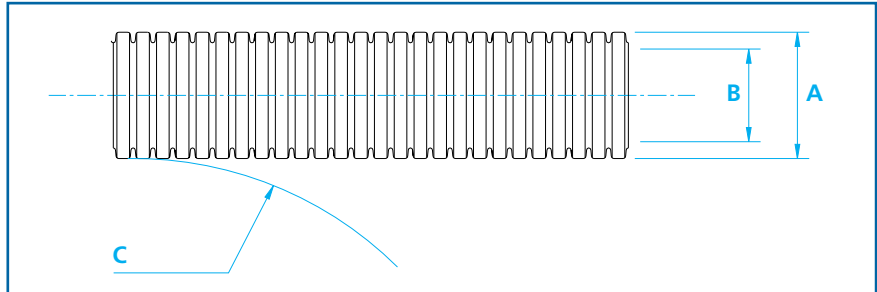

Configuration/nominal dimensions/part numbers

Part Number	Conduit Size		Nominal O/D A	Min Bore B	Min Static Bend Rad. B	Length (m)
PKC12	12 (NC)	10 (NW)	13.0	10.0	35	25
PKC16	16	13	15.8	11.9	45	25
PKC20	20	17	21.2	16.6	60	25
PKC28	28	23	28.5	21.7	65	25
PKC32	32	29	34.5	27.7	80	25

*NOTE: dimensions are in mm

HTC High Temperature Conduit

Description

A standard weight conduit suitable for static applications where elevated temperatures are present. High compression strength and excellent chemical resistance made from specially modified Nylon.

Applications

This conduit has been developed for use in engine areas where elevated temperatures occur. Suitable for long term exposure to 175°C.

HTC conduit configurations and dimensions

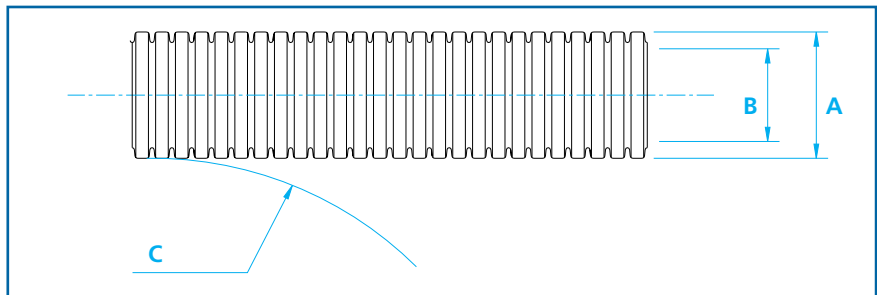

Configuration/nominal dimensions/part numbers

Part Number	Conduit Size		Nominal O/D A	Min Bore B	Min Static Bend Rad. B	Length (m)
HTC12	12 (NC)	10 (NW)	13.0	10.0	40	25
HTC16	16	13	15.8	11.9	45	25
HTC20	20	17	21.2	16.5	65	25
HTC25	25	22	25.6	21.3	75	25
HTC28	28	23	28.5	22.7	85	25
HTC32	32	29	34.5	28.8	100	25
HTC40	40	36	42.5	35.2	120	25
HTC50	50	48	54.5	46.5	140	25

*NOTE: dimensions are in mm

Hinged Fittings

Hinged Interfaces

Hinged fittings allow for protection of cables at breakouts, harness servability and for the conduit system to self level. They are designed to protect against high pressure washing, excessive cable strain and mechanical abrasion. Variety, flexibility and assembly speed are inherent in all Harnessflex fittings.

Quality & Standards

Manufacturing is controlled in accordance with BS EN ISO 9001 whilst ongoing testing & approval to international standards, eg: ADR, provides any additional confidence required to specify appropriate Harnessflex products across the widest variety of automotive applications including hazardous or aggressive environments.

All components comply with End of Life Vehicle (ELV) directive EU2000/53/EC. Harnessflex also comply to ISO14001 - Environmental Standard

Capabilities

Through our internal design team we are able to offer unique solutions, specific to our customers applications. Using the latest 3D CAD modelling software we are able to communicate new product designs quickly and efficiently. Rapid prototype parts can be made to order to enable product evaluation early on in the design cycle.

If you have a requirement for a dedicated hinged fitting please contact us to discuss your requirement.

Design Features

1. Radiussed internal form of conduit protects cables from abrasion.
2. Internal backstop (found on all hinged fittings) alleviates any potential problems caused by unevenly cut conduit.

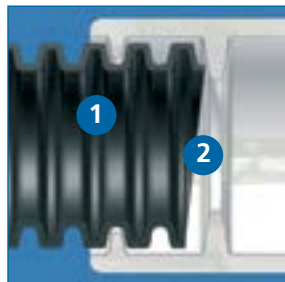

Hints & Tips

1. Multiple breakouts can be achieved from any NC20, NC25 or NC28 exit using our ST splitter range. See page 45 for details.
2. JPS & EPS fittings can be used as conduit enlargers or reducers.
3. Combining multiple XPS fittings (page 23) creates a self levelling manifold, ideal for engine bay or transmission applications.



External Hinged Joiners

External hinged joiners dimensions

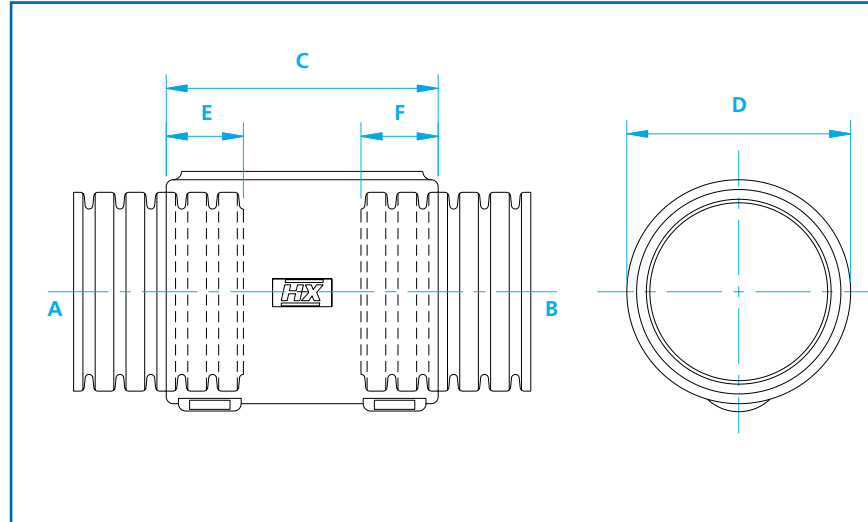

Description

One-piece joiner and elbow hinged fittings allow a variety of conduit size variations.

These fittings are designed to snap together over all types of slit and unslit conduit thus maintaining maximum conduit bore.

Can be used as a reducer as well as an enlarger.

External Joiner	Conduit Sizes (NC)		Conduit Sizes (NW)		C	D	E	F
	A	B	A	B				
JPS1208	12	08	10	7.5	38	16	10	10
JPS1212	12	12	10	10	36	16	10	10
JPS1612	16	12	13	10	36	21	10	10
JPS1616	16	16	13	13	36	21	10	10
JPS2008	20	08	17	7.5	38	26	12	10
JPS2012	20	12	17	10	38	26	12	10
JPS2016	20	16	17	13	38	26	12	10
JPS2020	20	20	17	17	38	26	12	12
JPS2520	25	20	22	17	39	33	12	12
JPS2525	25	25	22	22	39	33	13	13
JPS2820	28	20	23	17	39	33	13	13
JPS2825	28	25	23	22	39	33	13	13
JPS2828	28	28	23	23	39	33	13	13

*NOTE: dimensions are in mm



- One-piece external design**
Unrestricted bore and quick assembly requiring no tools
- Multiple size configurations**
Provides the right conduit size combination to suit all applications
- High pull-off strength**
Conduit corrugations sit tightly into joiner junctions
- Conduit size labels**
Each junction indicates nominal conduit size to aid installation

External Hinged Elbows

External hinged elbows dimensions

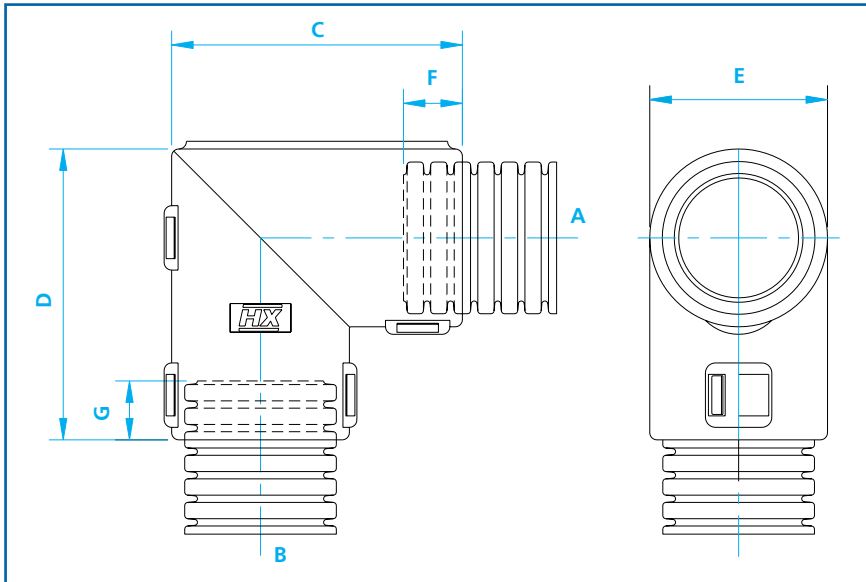

External Joiner	Conduit Sizes (NC)		Conduit Sizes (NW)		C	D	E	F	G
	A	B	A	B					
EPS08S08	08	08	7.5	7.5	38	29	20	10	10
EPS12S12	12	12	10	10	38	29	20	10	10
EPS0820	08	20	7.5	17	41	41	25	10	12
EPS1608	16	08	10	7.5	34	34	21	10	10
EPS1612	16	12	13	10	34	34	21	10	10
EPS1616	16	16	13	13	34	34	21	10	10
EPS2008	20	08	17	7.5	41	39	26	12	10
EPS2012	20	12	17	10	41	41	26	10	10
EPS2016	20	16	17	13	41	41	26	12	10
EPS2020	20	20	17	17	41	41	26	12	12
EPS2520	25	20	22	17	48	48	33	13	12
EPS2525	25	25	22	22	48	48	33	13	13
EPS2812	28	12	23	10	48	48	33	13	10
EPS2816	28	16	23	13	48	48	33	13	10
EPS2820	28	20	23	17	48	48	33	13	12
EPS2825	28	25	23	22	48	48	33	13	13
EPS2828	28	28	23	23	48	48	33	13	13

*NOTE: dimensions are in mm

Description

One-piece joiner and elbow hinged fittings allow a variety of conduit size variations.

These fittings are designed to snap together over all types of slit and unslit conduit thus maintaining maximum conduit bore.

Can be used as a reducer as well as an enlarger.

1 One-piece external design

Unrestricted bore and quick assembly requiring no tools

2 Multiple size configurations

Provides the right conduit size combination to suit all applications

3 High pull-off strength

Conduit corrugations sit tightly into joiner junctions

4 Conduit size labels

each junction indicates nominal conduit size to aid installation



External Hinged T-pieces

External T-piece dimensions

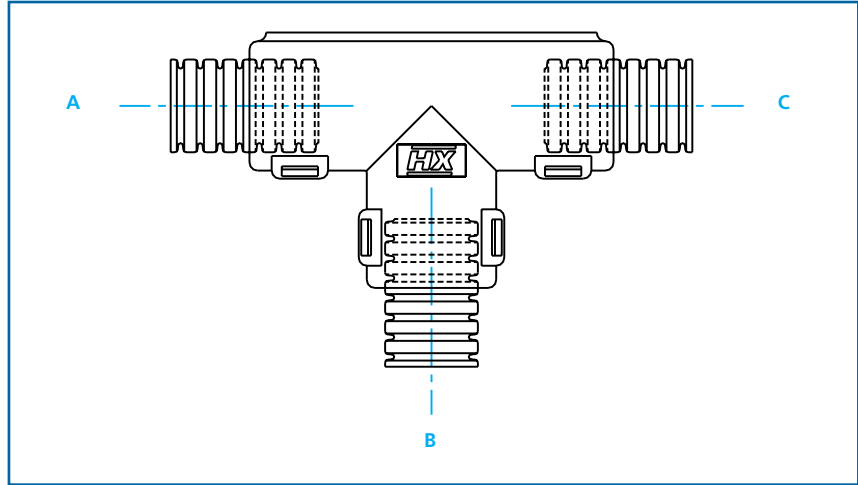

Description

One-piece symmetrical 3 junction fittings allow a variety of conduit size variations.

These fittings are designed to snap together over all types of slit and unslit conduit thus maintaining maximum conduit bore.

External T-piece dimensions

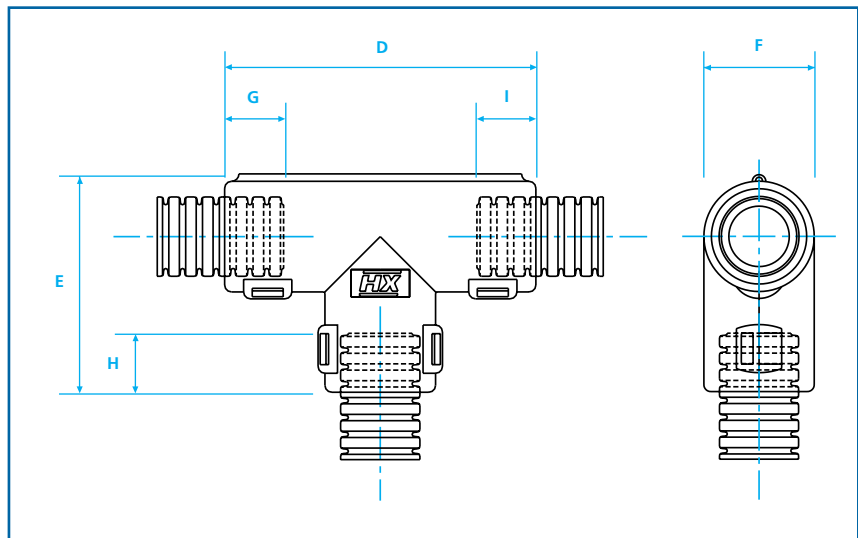

1 One-piece external design

Unrestricted bore and quick assembly requiring no tools

2 Multiple size configurations

Provides the right conduit size combination to suit all applications

3 High pull-off strength

Conduit corrugations sit tightly into joiner junctions

4 Conduit size labels

Each junction indicates nominal conduit size to aid installation

5 Integral retaining clips

Retains conduit in position during assembly

Part Number	Conduit Sizes						Nominal Dimensions					
	(NC)			(NW)			D	E	F	G	H	I
	A	B	C	A	B	C						
TPS080808	08	08	08	7.5	7.5	7.5	45.2	31.1	17	10	10	10
TPS081208	08	12	08	7.5	10	7.5	45.2	31.1	17	10	10	10
TPS081612	08	16	12	7.5	13	10	45.2	31.1	17	10	10	10
TPS100808	10	08	08	8.5	7.5	7.5	45.2	31.1	17	10	10	10
TPS100810	10	08	10	8.5	7.5	8.5	45.2	31.1	17	10	10	10
TPS101010	10	10	10	8.5	8.5	8.5	45.2	31.1	17	10	10	10
TPS101012	10	10	12	8.5	8.5	13	45.2	31.1	17	10	10	10
TPS120808	12	08	08	10	7.5	7.5	45.2	31.1	17	10	10	10
TPS120812	12	08	12	10	7.5	10	45.2	31.1	17	10	10	10
TPS121010	12	10	10	10	8.5	8.5	45.2	31.1	17	10	10	10
TPS121012	12	10	12	10	8.5	10	45.2	31.1	17	10	10	10
TPS121208	12	12	08	10	10	7.5	45.2	31.1	17	10	10	10
TPS121210	12	12	10	10	10	7.5	45.2	31.1	17	10	10	10
TPS121212	12	12	12	10	10	10	45.2	31.1	17	10	10	10
TPS121612	12	16	12	10	13	10	45.2	31.1	21	10	10	10
TPS160808	16	08	08	13	7.5	7.5	49.1	34.8	21	10	10	10
TPS160812	16	08	12	13	7.5	10	49.1	34.8	21	10	10	10
TPS160816	16	08	16	13	7.5	13	49.1	34.8	21	10	10	10
TPS161012	16	10	12	13	8.5	10	49.1	34.8	21	10	10	10
TPS161016	16	10	16	13	8.5	13	49.1	34.8	21	10	10	10
TPS161212	16	12	12	13	10	10	49.1	34.8	21	10	10	10
TPS161216	16	12	16	13	10	13	49.1	34.8	21	10	10	10
TPS161608	16	16	08	13	13	7.5	49.1	34.8	21	10	10	10
TPS161612	16	16	12	13	13	10	49.1	34.8	21	10	10	10
TPS161616	16	16	16	13	13	13	49.1	34.8	21	10	10	10
TPS162012	16	20	12	13	17	10	49.1	34.8	21	10	10	10
TPS162016	16	20	16	13	17	13	49.1	34.8	21	10	10	10
TPS200816	20	08	16	17	7.5	13	56.5	41.0	26	12	10	10
TPS200820	20	08	20	17	7.5	17	56.5	41.0	26	12	10	12
TPS201016	20	10	16	17	8.5	13	56.5	41.0	26	12	10	10
TPS201020	20	10	20	17	8.5	17	56.5	41.0	26	12	10	12
TPS201216	20	12	16	17	10	13	56.5	41.0	26	12	10	10
TPS201220	20	12	20	17	10	17	56.5	41.0	26	12	10	12
TPS201612	20	16	12	17	13	10	56.5	41.0	26	12	10	10
TPS201616	20	16	16	17	13	13	56.5	41.0	26	12	10	10
TPS201620	20	16	20	17	13	17	56.5	41.0	26	12	10	12
TPS202012	20	20	12	17	17	10	56.5	41.0	26	12	12	10
TPS202016	20	20	16	17	17	13	56.5	41.0	26	12	12	10
TPS202020	20	20	20	17	17	17	56.5	41.0	26	12	12	12
TPS202516	20	25	16	17	22	13	64.5	48.5	33	12	13	10
TPS250820	25	08	20	22	7.5	17	64.5	48.5	33	13	10	12
TPS250825	25	08	25	22	7.5	22	64.5	48.5	33	13	10	13
TPS251025	25	10	25	22	8.5	22	64.5	48.5	33	13	10	13
TPS251220	25	12	20	22	10	17	64.5	48.5	33	13	10	12
TPS251225	25	12	25	22	10	22	64.5	48.5	33	13	10	13
TPS251620	25	16	20	22	13	17	64.5	48.5	33	13	12	12
TPS251625	25	16	25	22	13	22	64.5	48.5	33	13	12	13
TPS252020	25	20	20	22	17	17	64.5	48.5	33	13	13	12
TPS252025	25	20	25	22	17	22	64.5	48.5	33	13	13	13

*NOTE: dimensions are in mm

Part Number	Conduit Sizes						Nominal Dimensions					
	(NC)			(NW)			D	E	F	G	H	I
	A	B	C	A	B	C						
TPS252520	25	25	20	22	22	17	64.5	48.5	33	13	10	12
TPS252525	25	25	25	22	22	22	64.5	48.5	33	13	10	13
TPS280820	28	08	20	23	7.5	17	64.5	48.5	33	13	10	12
TPS280828	28	08	28	23	7.5	23	64.5	48.5	33	13	10	13
TPS281020	28	10	20	23	8.5	17	64.5	48.5	33	13	10	12
TPS281028	28	10	28	23	8.5	23	64.5	48.5	33	13	10	13
TPS281220	28	12	20	23	10	17	64.5	48.5	33	13	10	13
TPS281225	28	12	25	23	10	22	64.5	48.5	33	13	10	12
TPS281228	28	12	28	23	10	23	64.5	48.5	33	13	10	13
TPS281620	28	16	20	23	13	17	64.5	48.5	33	13	10	12
TPS281625	28	16	25	23	13	22	64.5	48.5	33	13	10	13
TPS281628	28	16	28	23	13	23	64.5	48.5	33	13	10	13
TPS282020	28	20	20	23	17	17	64.5	48.5	33	13	12	12
TPS282025	28	20	25	23	17	22	64.5	48.5	33	13	12	13
TPS282028	28	20	28	23	17	23	64.5	48.5	33	13	12	13
TPS282525	28	25	25	23	22	22	64.5	48.5	33	13	13	13
TPS282528	28	25	28	23	22	23	64.5	48.5	33	13	13	13
TPS282828	28	28	28	23	23	23	64.5	48.5	33	13	13	13
TPS300830	30	8	30	26	7.5	26	72	55.3	39	12	10	12
TPS301230	30	12	30	26	10	26	72	55.3	39	12	10	12
TPS301625	30	16	25	26	13	2	72	55.3	39	12	10	12
TPS301630	30	16	30	26	13	26	72	55.3	39	12	10	12
TPS302016	30	20	16	26	17	13	72	55.3	39	12	12	10
TPS302020	30	20	20	26	17	17	72	55.3	39	12	12	12
TPS302025	30	20	25	26	17	2	72	55.3	39	12	12	12
TPS302030	30	20	30	26	17	26	72	55.3	39	12	12	12
TPS302525	30	25	25	26	22	22	72	55.3	39	12	12	12
TPS303025	30	30	25	26	26	22	72	55.3	39	12	12	12
TPS303030	30	30	30	26	26	26	72	55.3	39	12	12	12
TPS321625	32	16	25	29	13	22	72.0	55.3	39	13	10	13
TPS321632	32	16	32	29	13	29	72.0	55.3	39	13	10	13
TPS322532	32	25	32	29	22	29	72.0	55.3	39	13	10	13
TPS322025	32	20	25	29	17	22	72.0	55.3	39	13	12	13
TPS322028	32	20	28	29	17	23	72.0	55.3	39	13	12	13
TPS322032	32	20	32	29	17	29	72.0	55.3	39	13	12	13
TPS322525	32	25	25	29	22	22	72.0	55.3	39	13	13	13
TPS322532	32	25	32	29	22	29	72.0	55.3	39	13	13	13
TPS323225	32	32	25	29	29	22	72.0	55.3	39	13	13	13
TPS323232	32	32	32	29	29	29	72.0	55.3	39	13	13	13
TPS401232	40	12	32	36	10	29	85	65	47	15	10	12
TPS401240	40	12	40	36	10	36	87	65	47	15	10	15
TPS401632	40	16	32	36	13	29	85	65	47	15	10	12
TPS401640	40	16	40	36	13	36	87	65	47	15	10	15
TPS402040	40	20	40	36	17	36	87	65	47	15	12	15
TPS402540	40	25	40	36	22	36	87	65	47	15	12	15
TPS402840	40	28	40	36	23	36	87	65	47	15	12	15
TPS404032	40	40	32	36	36	29	85	70	47	15	15	12
TPS404040	40	40	40	36	36	36	87	70	47	15	15	15

*NOTE: dimensions are in mm

External Hinged Y-pieces



External Y-piece dimensions

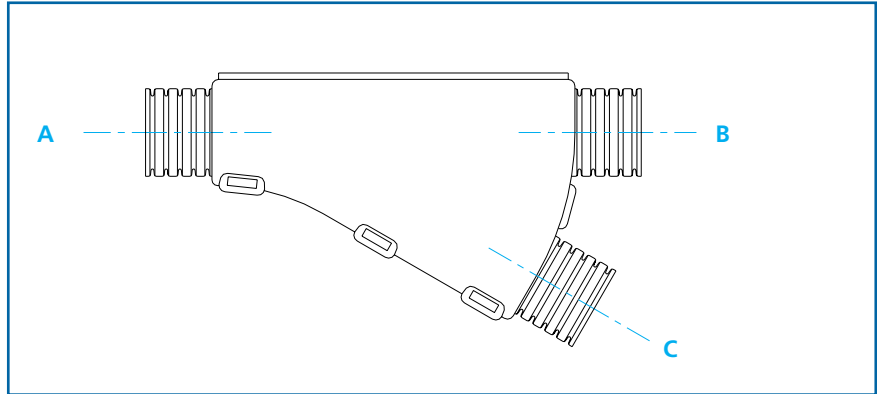

Description

One-piece asymmetrical 3 junction fittings allow a variety of conduit variations.

These fittings are designed to snap together over all types of slit and unslit conduit thus maintaining maximum conduit bore.

External Y-piece dimensions

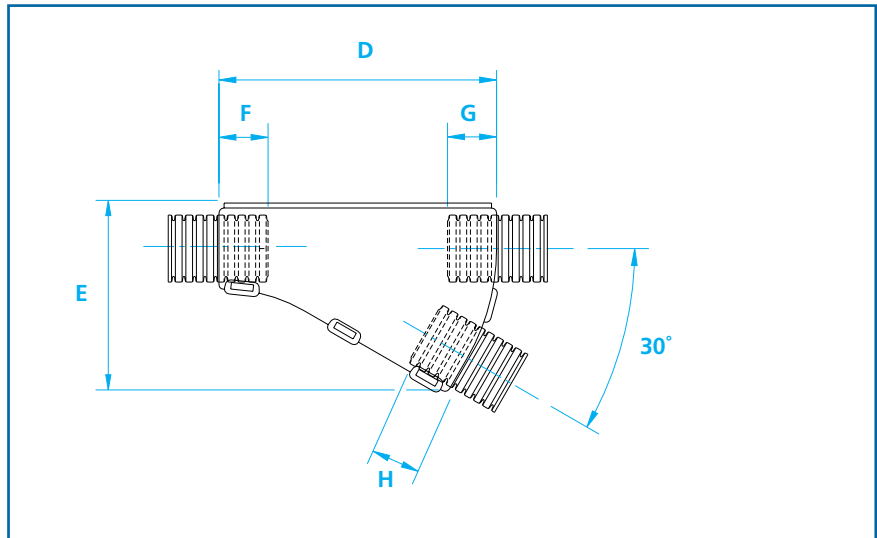

1 One-piece external design

Unrestricted bore and quick assembly requiring no tools

2 Multiple size configurations

Provides the right conduit size combination to suit all applications

3 High pull-off strength

Conduit corrugations sit tightly into joiner junctions

4 Conduit size labels

Each junction indicates nominal conduit size to aid installation



Part Number	Conduit Sizes						Nominal Dimensions					
	(NC)			(NW)			D	E	F	G	H	
	A	B	C	A	B	C						
YPS080808	08	08	08	7.5	7.5	7.5	55	37	10	10	10	
YPS080812	08	08	12	7.5	7.5	10	55	37	10	10	10	
YPS081208	08	12	08	7.5	10	7.5	55	37	10	10	10	
YPS101010	10	10	10	8.5	8.5	8.5	55	37	10	10	10	
YPS120808	12	08	08	10	7.5	7.5	55	37	10	10	10	
YPS120810	12	08	10	10	7.5	8.5	55	37	10	10	10	
YPS121010	12	10	10	10	8.5	8.5	55	37	10	10	10	
YPS121208	12	12	08	10	10	7.5	55	37	10	10	10	
YPS121210	12	12	10	10	10	8.5	55	37	10	10	10	
YPS121212	12	12	12	10	10	10	55	37	10	10	10	
YPS160812	16	08	12	13	7.5	10	55	37	10	10	10	
YPS161010	16	10	10	13	8.5	8.5	55	40	10	10	10	
YPS161208	16	12	08	13	10	7.5	55	40	10	10	10	
YPS161210	16	12	10	13	10	8.5	55	40	10	10	10	
YPS161212	16	12	12	13	10	10	55	40	10	10	10	
YPS161608	16	16	08	13	13	7.5	55	40	10	10	10	
YPS161610	16	16	10	13	13	8.5	55	40	10	10	10	
YPS161612	16	16	12	13	13	10	55	40	10	10	10	
YPS200808	20	08	08	17	7.5	7.5	43	37	12	10	10	
YPS201208	20	12	08	17	10	7.5	43	37	12	10	10	
YPS201210	20	12	10	17	10	8.5	43	37	12	10	10	
YPS201212	20	12	12	17	10	10	43	37	12	10	10	
YPS201608	20	16	08	17	13	7.5	43	37	12	10	10	
YPS201612	20	16	12	17	13	10	48	40	12	10	10	
YPS201616	20	16	16	17	13	13	48	40	12	10	10	
YPS202008	20	20	08	17	17	7.5	56	45	12	10	10	
YPS202010	20	20	10	17	17	8.5	58	45	12	12	10	
YPS202012	20	20	12	17	17	10	58	45	12	12	10	
YPS202016	20	20	16	17	17	13	64	48	12	12	10	
YPS252012	20	20	12	22	17	10	54	49	13	12	10	
YPS252016	25	20	16	22	17	13	54	49	10	12	10	
YPS252020	25	20	20	22	17	17	54	49	10	12	12	
YPS252508	25	25	08	22	22	7.5	67	56	10	12	10	
YPS252510	25	25	10	22	22	8.5	67	56	10	13	10	
YPS252512	25	25	12	22	22	10	67	56	10	13	10	

*NOTE: dimensions are in mm

Part Number	Conduit Sizes						Nominal Dimensions					
	(NC)			(NW)			D	E	F	G	H	
	A	B	C	A	B	C						
YPS252516	25	25	16	22	22	13	67	56	10	13	10	
YPS252520	25	25	20	22	22	17	77	60	10	13	12	
YPS252525	25	25	25	22	22	22	91	67	10	13	13	
YPS282012	28	20	12	23	17	10	54	49	10	13	10	
YPS282016	28	20	16	23	17	13	54	49	10	12	10	
YPS282020	28	20	20	23	17	17	54	49	10	12	12	
YPS282512	28	25	12	23	22	10	67	56	10	12	10	
YPS282516	28	25	16	23	22	13	67	56	10	13	10	
YPS282520	28	25	20	23	22	17	77	60	10	13	12	
YPS282525	28	25	25	23	22	22	91	67	10	13	13	
YPS282808	28	28	08	23	23	7.5	67	56	10	13	10	
YPS282812	28	28	12	23	23	10	67	56	10	13	10	
YPS282816	28	28	16	23	23	13	67	56	10	13	10	
YPS282820	28	28	20	23	23	17	77	60	10	13	12	
YPS282825	28	28	25	23	23	22	91	67	12	13	13	
YPS282828	28	28	28	23	23	23	91	67	12	13	13	
YPS322516	32	25	16	29	22	13	100	75	12	13	10	
YPS322520	32	25	20	29	22	17	100	76	12	13	12	
YPS322525	32	25	25	29	22	22	100	79	12	13	13	
YPS322532	32	25	32	29	22	29	100	82	12	13	13	
YPS323216	32	32	16	29	29	13	100	75	12	13	10	
YPS323220	32	32	20	29	29	17	100	76	12	13	12	
YPS323225	32	32	25	29	29	22	100	79	12	13	13	
YPS323232	32	32	32	29	29	29	100	82	13	13	13	
YPS403212	40	32	12	36	29	10	133	91	15	12	10	
YPS403216	40	32	16	36	29	13	133	92	15	12	10	
YPS403225	40	32	25	36	29	22	133	92	15	12	12	
YPS403228	40	32	28	36	29	23	133	92	15	12	12	
YPS404012	40	40	12	36	36	10	135	93	15	15	10	
YPS404016	40	40	16	36	36	13	135	93	15	15	10	
YPS404025	40	40	25	36	36	22	135	93	15	15	12	
YPS404028	40	40	28	36	36	23	135	93	15	15	12	
YPS404032	40	40	32	36	36	29	135	96	15	15	12	
YPS404040	40	40	40	36	36	36	135	100	15	15	15	

*NOTE: dimensions are in mm

External Hinged Protective Shrouds



Description

One-piece cover providing protection for in-line connectors, fuse links, circuit breakers and splicing areas.

The CPS shrouds can be used as a harness datum, due to the interated cable tie/fir tree facility.

The strong construction allows for the protection of delicate connections, or as an alternative when an interface/ backshell isn't available.

These fittings are designed to snap together over all types of slit and unslit conduit thus maintaining maximum conduit bore.

External hinged protective shrouds configurations

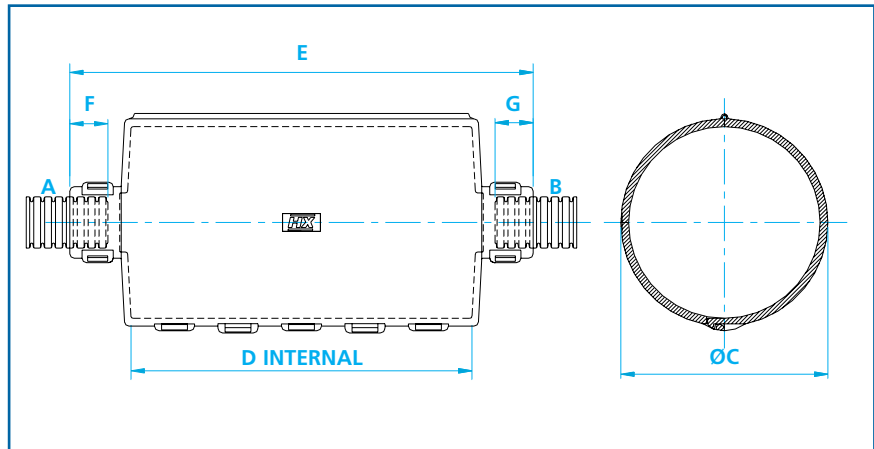

External Joiner	Internal Diameter	Conduit Sizes (NC)		Conduit Sizes (NW)		C	D	E	F	G
		A	B	A	B					
CPS341212	35	12	12	10	10	38	73	100	10	10
CPS421212	43	12	12	10	10	47	77	104	10	10
CPS421616	43	16	16	13	13	47	77	104	10	10
CPS421620	43	16	20	13	17	47	77	104	10	12
CPS422020	43	20	20	17	17	47	77	104	12	12

*NOTE: dimensions are in mm

1 One-piece external design

Unrestricted bore and quick assembly requiring no tools

2 High pull-off strength

Conduit corrugations sit tightly into joiner junctions

3 Ease of installation

Provides easy access to re-enter after installation



X-Pieces

External X-piece dimensions

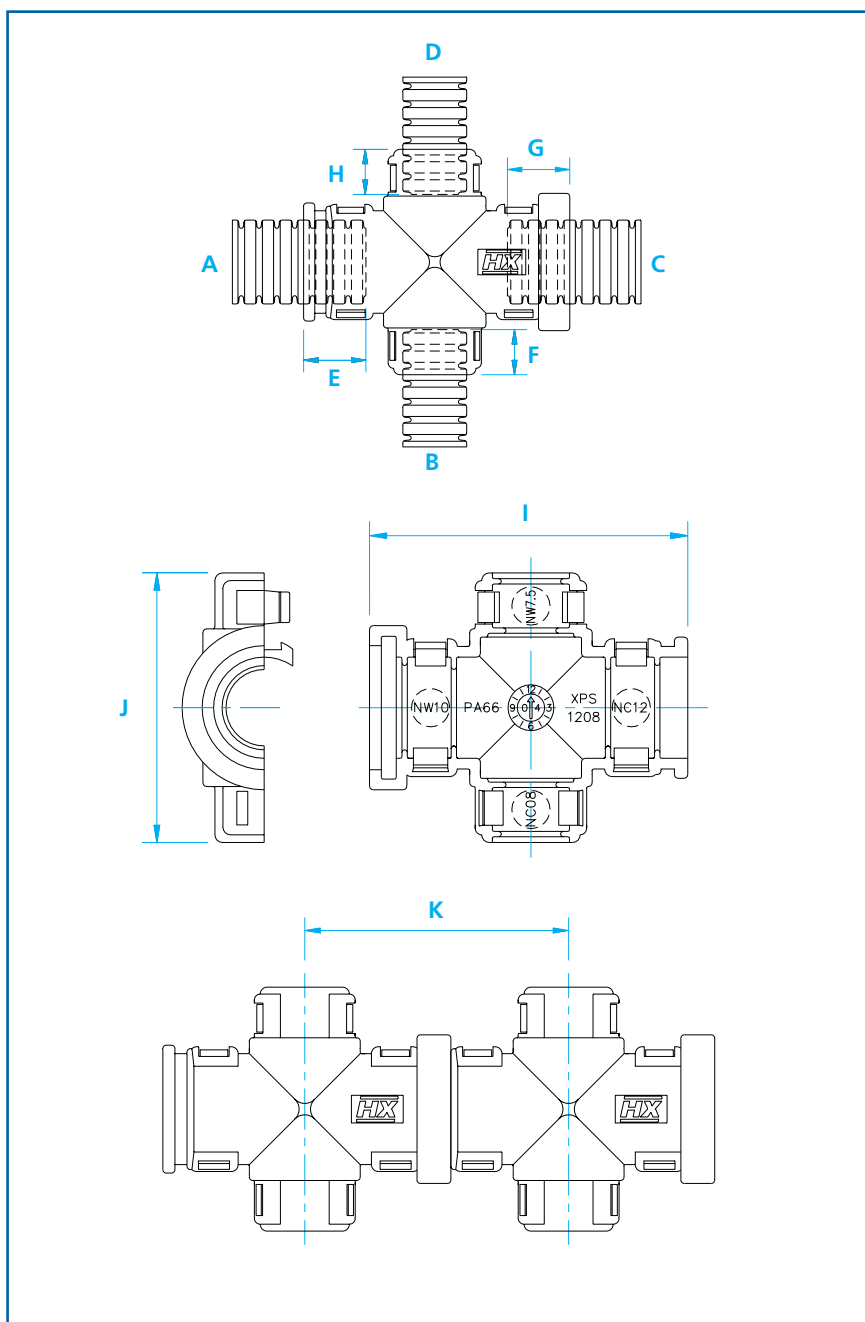

Configuration/part numbers

Part Number	Conduit Sizes (NC)				Conduit Sizes (NW)				Conduit Engagement				Overall Dimensions			
	A	B	C	D	A	B	C	D	E	F	G	H	I	J	K	
XPS1208	12	08	12	08	10	7.5	10	7.5	9.5	7.0	9.5	7.0	42	3	5.5	38.0

*NOTE: dimensions are in mm



Description

Two-piece symmetrical 4 junction fittings providing a variety of conduit size combinations.

These fittings are designed to snap together over all types of slit and unslit conduit thus maintaining maximum conduit bore.

In addition, several fittings can be snapped together to provide multiple outlets without the need of short conduit joints.

1 Compact design
Reducing distance between centres

2 High pull-off strength
Conduit corrugations sit tightly into joiner junctions

3 Snap together
Fittings can be linked together for multiple outlet options without the need for short conduit joints



Custom Hinged Manifolds



Description

One-piece hinged fittings designed to suit specific project or application requirements.

For Blanking Caps see page 46.

Nominal dimensions

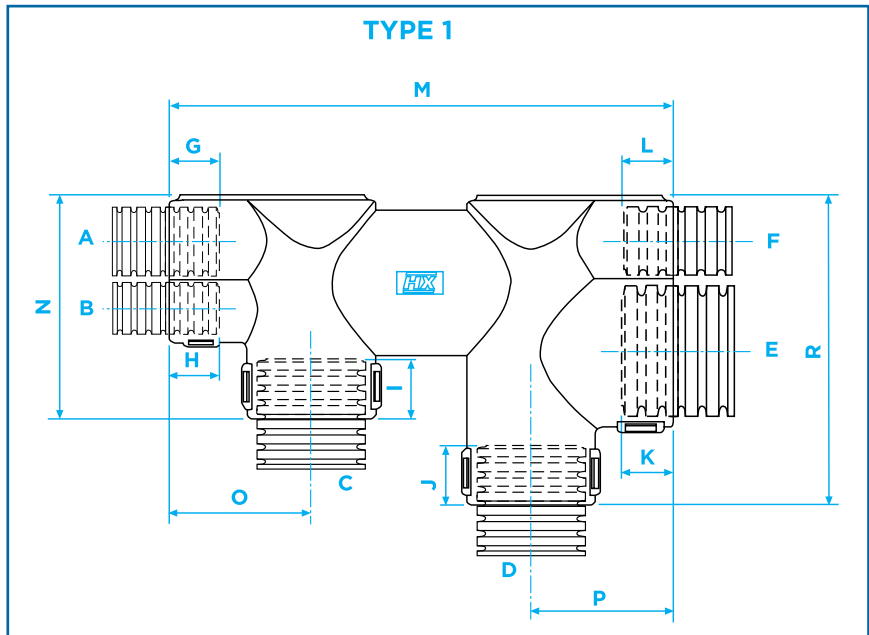

1 Multiple outlet options

2 Outlets can be blanked

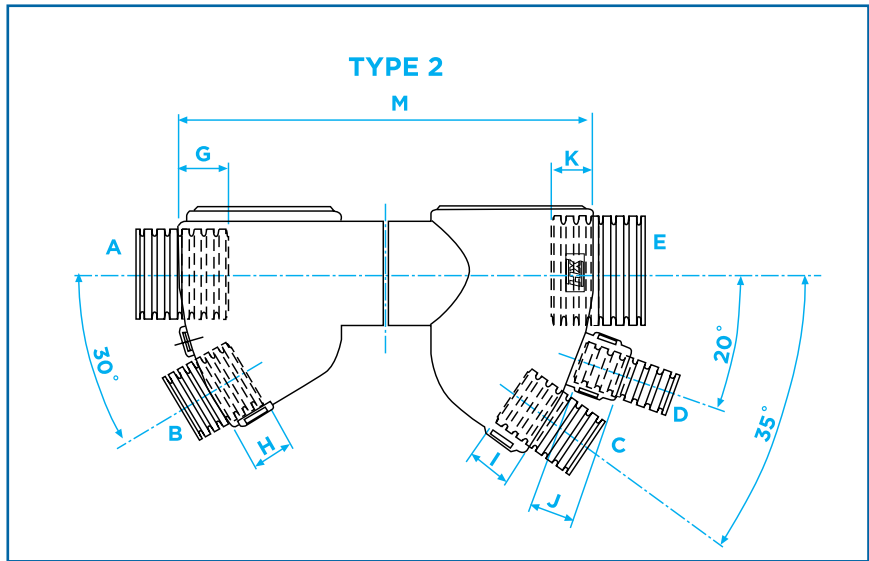

Nominal dimensions

Product Number	Type	Conduit Sizes (NC)					Conduit Sizes (NW)					Overall Dimensions					Weight		
		A	B	C	D	E	F	G	H	I	J	K	L	M	N	O		P	R
MPS100	1	12	08	20	20	25	12	10	10	12	12	13	12	98	43	28	28	59	22
MPS101	2	20	16	16	08	25	-	12	10	10	10	13	-	97	-	-	-	-	23
MPS102	2	16	08	16	08	25	-	10	10	10	10	13	-	97	-	-	-	-	23
MPS103	2	16	16	16	08	25	-	10	10	10	10	13	-	97	-	-	-	-	23

*NOTE: dimensions are in mm

Split Manifolds

Split manifold dimensions

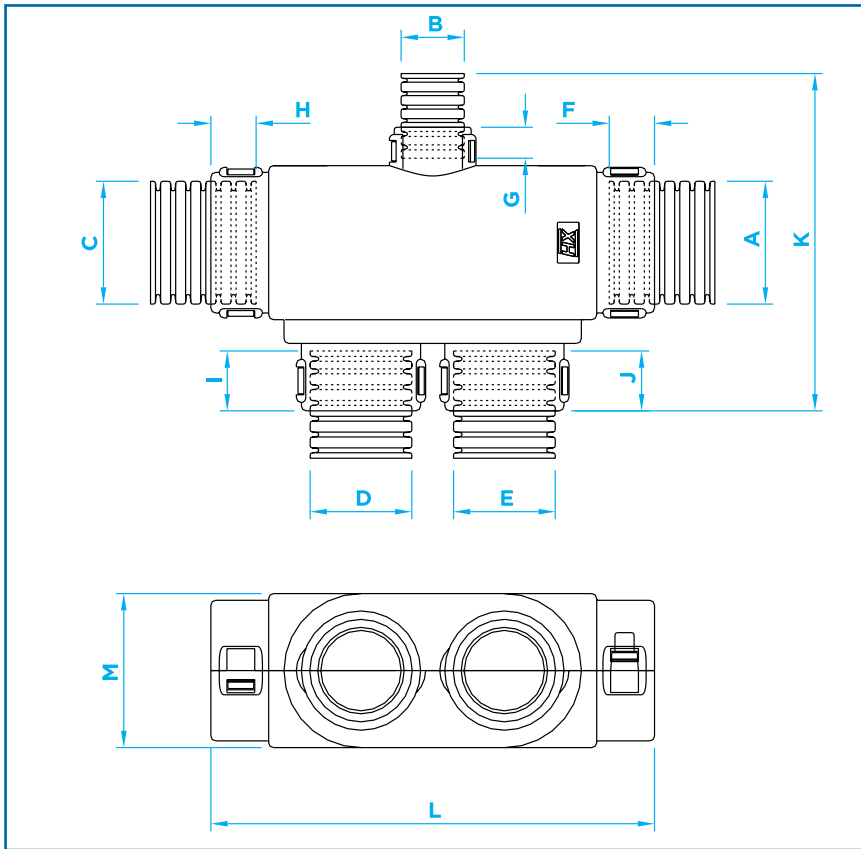

Description

Two identical half shells snap together to give a 5-way conduit manifold.

This fitting is designed to fit different types of slit and unslit conduit including NC, CPTA, modified PP and deep section PP.

Additional configurations possible (dependent on volume). Contact us for details.

For Blanking Caps see page 46.

Configuration/part numbers

Product Number	Conduit Sizes (NC)					Nominal Dimensions							
	A	B	C	D	E	F	G	H	I	J	K	L	M
MPS121212-2020	12	12	12	20	20	10	7	10	10	10	59	92	32
MPS122812-2020	12	28	12	20	20	10	12	10	10	10	67	92	32
MPS201220-2020	20	12	20	20	20	12	7	12	10	10	59	92	32
MPS202820-2020	20	28	20	20	20	12	12	12	10	10	67	92	32
MPS251225-2020	25	12	25	20	20	11	7	11	10	10	59	92	32
MPS252825-2020	25	28	25	20	20	11	12	11	10	10	67	92	32

*NOTE: dimensions are in mm

- ① Multiple outlet options
- ② Outlets can be blanked
- ③ Part fitting



Accessories In-line Hinged Circular Manifolds

in-line circular manifolds dimensions

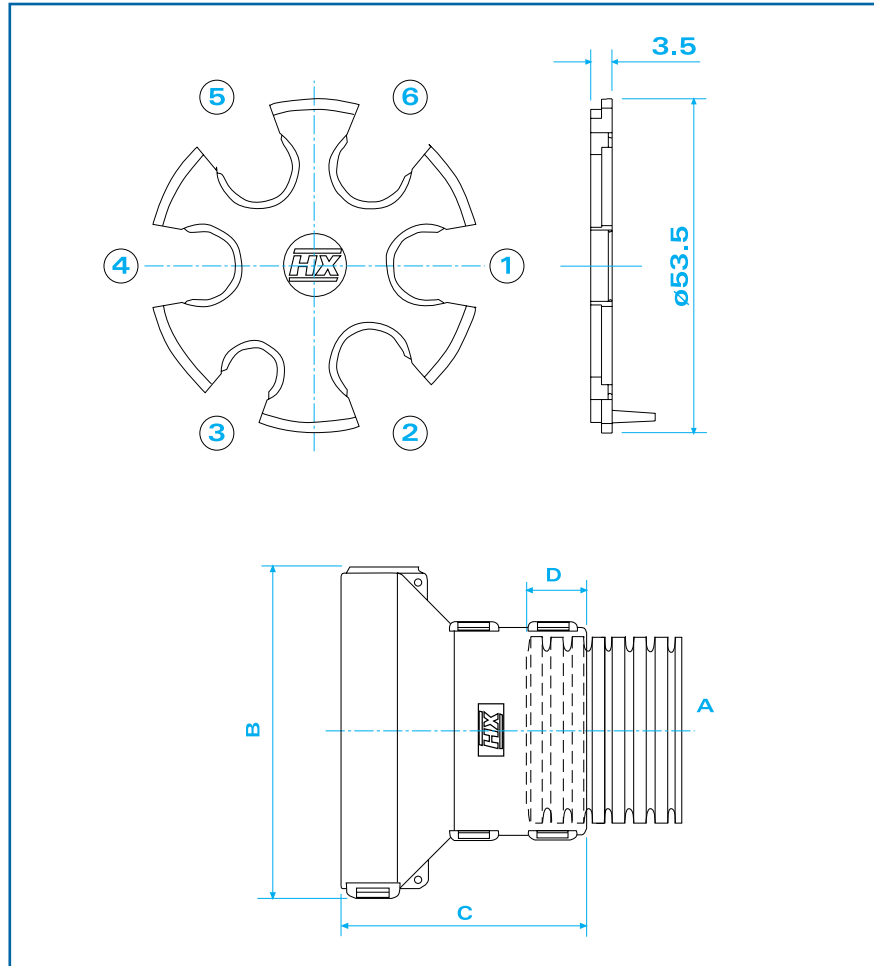

Description

One-piece straight fittings providing in-line 'customised' combinations of multiple conduit breakouts.

ST break out disk configuration can be made to order, for more details see website for specification and ordering sheet.

Nominal dimensions

Part Number	Conduit A		Nominal Dimensions		
	NC	NW	B	C	D
CI16-A31	16	13	62	45	10
CI20-A31	20	17	62	45	12
CI25-A31	25	22	62	45	13
CI32-A31	32	29	62	45	13

*NOTE: dimensions are in mm

Part Number	Breakout Type					
	1	2	3	4	5	6
ST31-100	NC08	NC08	NC08	BLANK	NC08	NC08
ST31-101	NC12	NC12	NC08	BLANK	BLANK	NC12
ST31-102	NC08	NC08	NC08	NC08	NC08	NC08

*NOTE: other configurations available on request

Interfaces

Interfaces

Vehicle electrical system faults are often traced to problems at the cable entry points of electrical connectors. Harnessflex connector interfaces are designed to protect against the high pressure wash-down, excessive cable strain and mechanical abrasion identified as the principle causes. Variety, flexibility and assembly speed are inherent in all Harnessflex fittings.

Quality & Standards

Manufacturing is controlled in accordance with BS EN ISO 9001 whilst ongoing testing & approval to international standards, eg: ADR, provides any additional confidence required to specify appropriate Harnessflex products across the widest variety of automotive applications including hazardous or aggressive environments.

All components comply with End of Life Vehicle (ELV) directive EU2000/53/EC. Harnessflex also comply to ISO14001 - Environmental Standard

Capabilities

Harnessflex works closely with many blue chip companies in the development of protection for electrical connectors (a critical area of an engine harness).

Our experienced internal design team use 3D CAD modelling software to produce various concepts for customer approval.

Once a design is selected, a rapid prototype of the interface can be supplied to enable a pre-production harness to be assembled.

These prototype parts can be used for validation purposes, due to the close approximation of properties of the material used in the prototyping process and Polyamide 6,6 used in our injection moulded components (see page 46 for material specification).

With Harnessflex's history of connector interface design and our understanding of customers requirements, we are well placed to produce bespoke designs to integrate any electrical connector into a harness design.

Hints & Tips

1. Interfaces can be used in areas where electrical connectors are vulnerable to high pressure washing.
2. Our interfaces offer strain relief to crimped contacts.
3. When our 90° swivel elbows are used with interfaces they allow the harness to self level.
4. Using our part CI-MF-90, in addition to a standard 90° swivel fitting, a 180° swivel bend is possible.



AMP Superseal External Hinged Connector Interfaces

Description

Single junction straight and 90° elbow fittings providing high integrity connections between AMP Superseal or Junior timer connectors and Harnessflex conduit systems.

These fittings are designed to snap together over all types of slit and unslit conduit thus maintaining maximum conduit bore.

In addition, 90° elbow versions allow the conduit to swivel 360° around the connector housing, sufficient to avoid the problems associated with one-piece interfaces of overflexing due to movement or vibration.

External connector interface dimensions

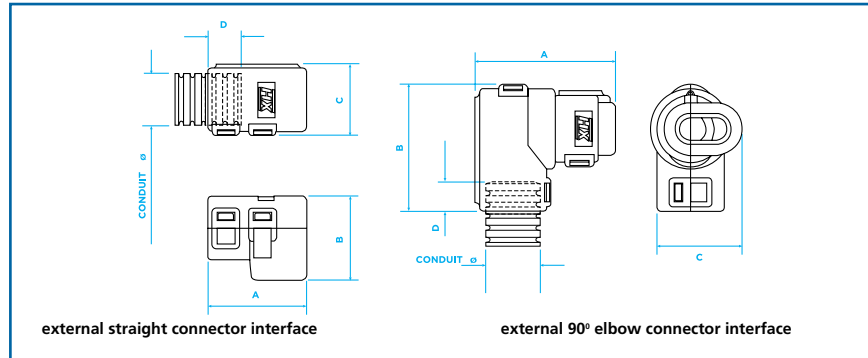

1 High pull-off strength

Conduit corrugations sit tightly into joiner junctions

2 Integral overcentre facility

Holds conduit securely in place during harness fabrication

3 Conduit size labels

Each junction indicates nominal conduit size to aid installation

4 Straight or 90° elbow versions

Compact design ideal for use where space is limited

5 Elbow swivels

For easy installation

Configurations/part numbers (AMP Superseal)

Part No. Straight Interface	Part No. 90° Elbow Swivel Interface	Conduct Size (NC)	Conduct Size (NW)	Connector Ref
CI08-AS1	CI08-90-AS1	08	7.5	AMP Superseal 1-way
CI08-AS2	CI08-90-AS2	08	7.5	AMP Superseal 2-way
CI08-AS3	CI08-90-AS3	08	7.5	AMP Superseal 3-way
CI08-AS4	CI08-90-AS4	08	7.5	AMP Superseal 4-way
CI10-AS2	CI10-90-AS2	10	8.5	AMP Superseal 2-way
CI10-AS3	CI10-90-AS3	10	8.5	AMP Superseal 3-way
CI10-AS4	CI10-90-AS4	10	8.5	AMP Superseal 4-way
CI12-AS1	CI12-90-AS1	12	10	AMP Superseal 1-way
CI12-AS2	CI12-90-AS2	12	10	AMP Superseal 2-way
CI12-AS3	CI12-90-AS3	12	10	AMP Superseal 3-way
CI12-AS4	CI12-90-AS4	12	10	AMP Superseal 4-way

*NOTE: dimensions are in mm

Nominal dimensions (AMP Superseal)

Part No. Straight Interface	Part No. 90° Elbow Swivel Interface			
	A	B	C	D
CI08-AS1	23.6	16.1	18	10
CI08-AS2	22.4	20.5	18	10
CI08-AS3	22.4	26.5	18	10
CI08-AS4	34	33	18	10
CI10-AS2	34	21	20	10
CI10-AS3	34	27	20	10
CI10-AS4	34	33	20	10
CI12-AS1	23.6	16.1	18	10
CI12-AS2	22.4	20.5	18	10
CI12-AS3	22.4	26.5	18	10
CI12-AS4	34	33	19	10

*NOTE: dimensions are in mm

AMP Junior & Mini Timer External Hinged Connector Interfaces

External connector interface dimensions

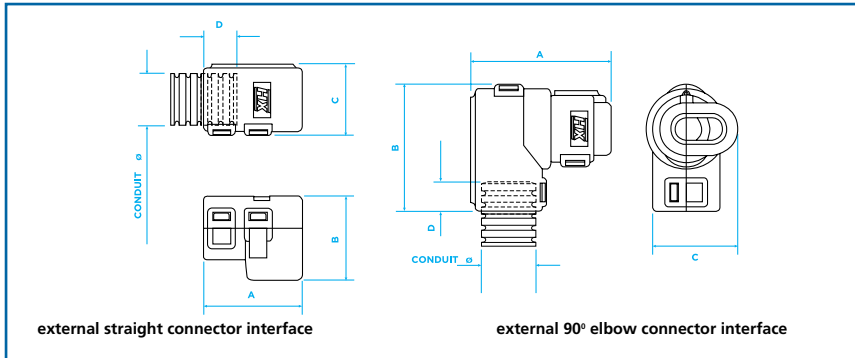

Configurations/part numbers (AMP Junior timer)

Part No. Straight Interface	Part No. 90° Elbow Swivel Interface	Conduct Size (NC)	Conduct Size (NW)	Connector Ref
CI08-AM2	CI08-90-AM2	08	7.5	AMP Junior timer 2-way
CI08-AM3	CI08-90-AM3	08	7.5	AMP Junior timer 3-way
CI08-AM4	CI08-90-AM4	08	7.5	AMP Junior timer 4-way
CI10-AM2	CI10-90-AM2	10	8.5	AMP Junior timer 2-way
CI10-AM3	CI10-90-AM3	10	8.5	AMP Junior timer 3-way
CI10-AM4	CI10-90-AM4	10	8.5	AMP Junior timer 4-way
CI12-AM2	CI12-90-AM2	12	10	AMP Junior timer 2-way
CI12-AM3	CI12-90-AM3	12	10	AMP Junior timer 3-way
CI12-AM4	CI12-90-AM4	12	10	AMP Junior timer 4-way

*NOTE: dimensions are in mm

Configurations/part numbers (AMP Mini timer)

CI12-X01	CI12-90-X01	12	10	AMP Mini timer 1-way
----------	-------------	----	----	----------------------

Nominal dimensions (AMP Junior timer)

Part No. Straight Interface					Part No. 90° Elbow Swivel Interface				
	A	B	C	D		A	B	C	D
CI08-AM2	24.9	21.3	18	10	CI08-90-AM2	35.7	30.3	21.3	7
CI08-AM3	24.9	27.2	18	10	CI08-90-AM3	35.7	30.3	27.2	7
CI08-AM4	37	32	19	10	CI08-90-AM4	39.5	30.3	32	7
CI10-AM2	37	21	19	10	CI10-90-AM2	37.5	38	21.3	10
CI10-AM3	37	27	19	10	CI10-90-AM3	37.5	38	27.2	10
CI10-AM4	37	32	19	10	CI10-90-AM4	41.2	38	32	10
CI12-AM2	24.9	21.3	18	10	CI12-90-AM2	35.7	30.3	21.3	7
CI12-AM3	24.9	27.2	18	10	CI12-90-AM3	35.7	30.3	27.2	7
CI12-AM4	37	32	19	10	CI12-90-AM4	39.5	30.3	32	7

Nominal dimensions (AMP Mini timer)

	A	B	C	D		A	B	C	D
CI12-X01	34	16.2	19.6	10	CI12-90-X01	37	30.3	19	10

*NOTE: dimensions are in mm



1 High pull-off strength

Conduit corrugations sit tightly into joiner junctions

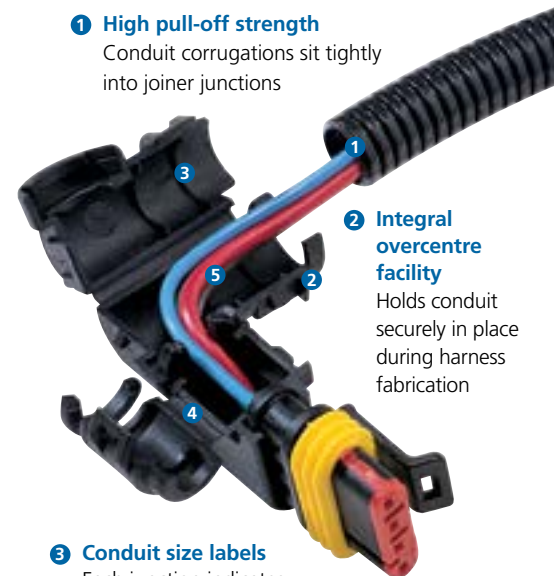

2 Integral overcentre facility

Holds conduit securely in place during harness fabrication

3 Conduit size labels

Each junction indicates nominal conduit size to aid installation

4 Straight or 90° elbow versions

Compact design ideal for use where space is limited

5 Elbow swivels

For easy installation

AMPSEAL 16 External Hinged Connector Interfaces



External connector interface dimensions (Ampseal - Straight)

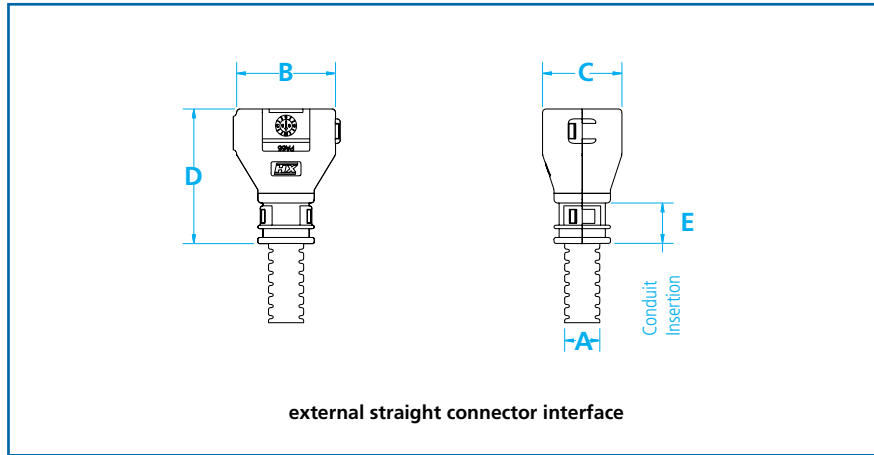

Description

A range of straight and 90° elbow fittings offering a compact and high integrity connection between Ampseal automotive connectors and Harnessflex conduit systems.

These interfaces provide complete cable protection right up to the connector. They also provide strain relief and protection from high pressure washing, helping to maintain the sealing integrity of the connector.

The 90° elbow allows the conduit to swivel 360° around the connector housing, sufficient to avoid the problems associated with one-piece interfaces of over flexing due to movement or vibration.

These fittings are designed to snap together over all types of slit and unslit conduit thus maintaining maximum conduit bore.

Nominal dimensions (Ampseal - Straight)

Part Number	Connector	Conduit Size				
		A	B	C	D	E
CI08-AT2PL	2 Way	NC08	23	18	34	12
CI08-AT3PL	3 Way	NC08	28	18	33	11
CI08-AT4PL	4 Way	NC08	29	23	39	13
CI12-AT4PL	4 Way	NC12	29	23	37	11
CI12-AT6PL	6 Way	NC12	29	23	37	11
CI12-AT8PL	8 Way	NC12	32	23	37	11
CI12-AT12PL	12 Way	NC12	41	23	37	11
CI16-AT8PL	8 Way	NC16	32	23	37	11
CI16-AT12PL	12 Way	NC16	41	23	37	11
CI20-AT20PL	20 Way	NC20	41	23	48	12

*NOTE: dimensions are in mm

Configurations/part numbers (Ampseal - 90° elbow)

Part No.	Conduit Size		B	C	D	E
	(NC)	(NW)				
CI08-90-AT2LP	08	7.5	37.3	25	17	7.1
CI08-90-AT2LR	08	7.5	37.3	25	20	7.1
CI08-90-AT3LP	08	7.5	39.8	29	17.1	7.1
CI08-90-AT3LR	08	7.5	39.8	29	17.1	7.1
CI08-90-AT4LP	08	7.5	40.8	29.4	20.6	7.1
CI08-90-AT4LR	08	7.5	40.8	29.4	20.6	7.1
CI08-90-AT6LP	08	7.5	42.8	29.4	22.5	7.1
CI08-90-AT6LR	08	7.5	42.8	29.4	22.5	7.1

*NOTE: dimensions are in mm

External connector interface dimensions (Ampseal - 90° elbow)

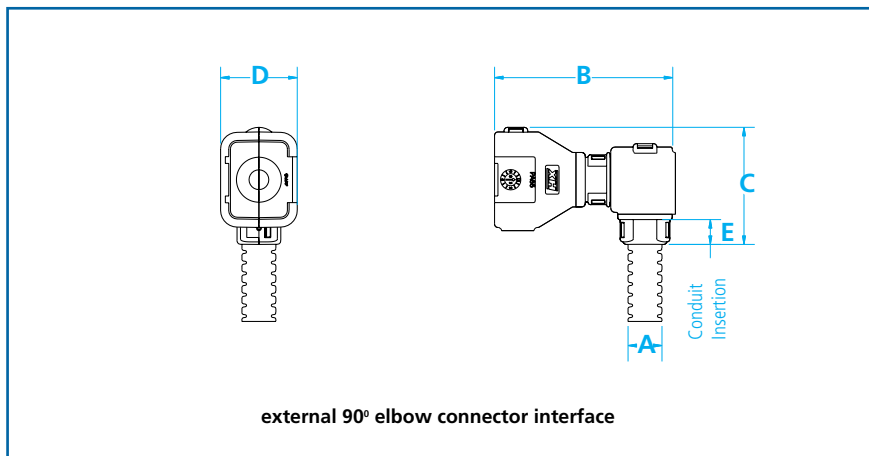

Nominal dimensions (Ampseal - 90° elbow)

Part No.	Conduit Size		B	C	D	E
	(NC)	(NW)				
CI08-90-AT2PL	2 Way	NC08	49	32	20	7.1
CI08-90-AT3PL	3 Way	NC08	49	34	20	7.1
CI08-90-AT4PL	4 Way	NC08	53	34	23	7.1
CI12-90-AT2PL	2 Way	NC12	49	32	20	7.1
CI12-90-AT3PL	3 Way	NC12	49	34	20	7.1
CI12-90-AT4PL	4 Way	NC12	53	35	23	7.1

*NOTE: dimensions are in mm

Configurations/part numbers (Ampseal - 90° elbow)

Part No.	Conduit Size		B	C	D	E
	(NC)	(NW)				
CI12-90-AT2LP	12	10	38	23	20	7.1
CI12-90-AT2LR	12	10	38	23	20	7.1
CI12-90-AT3LP	12	10	40.2	27.1	17.1	7.1
CI12-90-AT3LR	12	10	40.2	27.1	17.1	7.1
CI12-90-AT4LP	12	10	41.1	27.5	20.6	7.1
CI12-90-AT4LR	12	10	41.1	27.5	20.6	7.1
CI12-90-AT6LP	12	10	43.1	27.5	22.5	7.1
CI12-90-AT6LR	12	10	43.1	27.5	22.5	7.1

*NOTE: LP = Plug, LR = Receptacle **NOTE: dimensions are in mm

1 High pull-off strength

Conduit corrugations sit tightly into joiner junctions



2 Integral overcentre facility

Holds conduit securely in place during harness fabrication

3 Conduit size labels

Each junction indicates nominal conduit size to aid installation

4 Straight or 90° elbow versions

Compact design ideal for use where space is limited

5 Elbow swivels

For easy installation

Deutsch - DT series External Hinged Connector Interfaces



Description

Single junction straight and 90° elbow fittings providing high integrity connections between Deutsch DT connectors and Harnessflex conduit systems.

These fittings are designed to snap together over all types of slit and unslit conduit thus maintaining maximum conduit bore.

In addition, 90° elbow versions allow the conduit to swivel 360° around the connector housing, sufficient to avoid the problems associated with one-piece interfaces of overflexing due to movement or vibration.

The functionality of a connector when attached to a Harnessflex Product depends on the application, installation and operational criteria determined by the user.

For connector part no's. look up table see page 71.

External connector interface dimensions (straight connector)

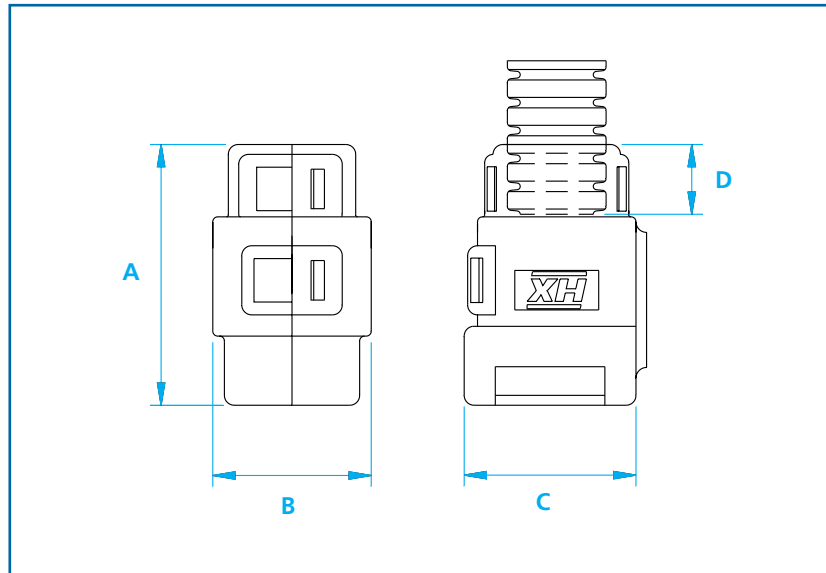

(90° connector)

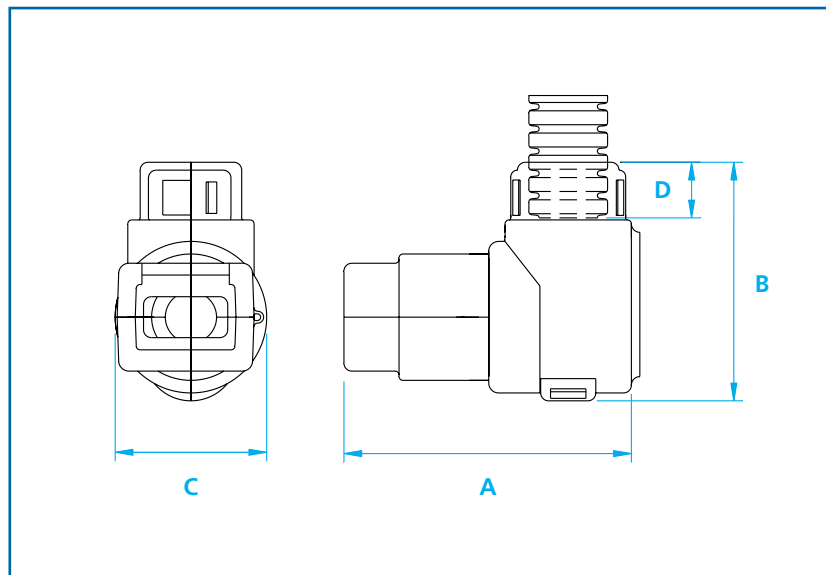

Configurations/part numbers (DEUTSCH DT)

Part No. Straight Interface	Part No. 90° Elbow Swivel Interface	Conduit Size		Connector Ref
		(NC)	(NW)	
CI08-DT2	CI08-90-DT2	08	7.5	2-way
CI08-DT3	CI08-90-DT3	08	7.5	3-way
CI08-DT4	CI08-90-DT4	08	7.5	4-way
CI08-DT6	CI08-90-DT6	08	7.5	6-way
CI12-DT2	CI12-90-DT2	12	10	2-way
CI12-DT3	CI12-90-DT3	12	10	3-way
CI12-DT4	CI12-90-DT4	12	10	4-way
CI12-DT6	CI12-90-DT6	12	10	6-way
CI12-DT8	CI12-90-DT8	12	10	8-way
-	CI12-90-DT12	12	10	12-way
-	CI16-90-DT8	16	13	8-way
CI16-DT12	CI16-90-DT12	16	13	12-way

*NOTE: dimensions are in mm



Nominal dimensions (DEUTSCH DT)

Part no. straight interface	Part no.				Part no. 90° elbow swivel interface	Part no.			
	A	B	C	D		A	B	C	D
CI08-DT2	26	16	18	7	CI08-90-DT2	36	30	19	7
CI08-DT3	30	22	24	12	CI08-90-DT3	44	30	23	7
CI08-DT4	42	18	27	12	CI08-90-DT4	48	30	25	7
CI08-DT6	42	22	27	12	CI08-90-DT6	48	34	25	7
CI12-DT2	26	16	18	7	CI12-90-DT2	36	30	19	7
CI12-DT3	29	22	24	7	CI12-90-DT3	44	30	23	7
CI12-DT4	40	18	27	7	CI12-90-DT4	48	30	25	7
CI12-DT6	40	22	27	10	CI12-90-DT6	48	34	25	7
CI12-DT8	40	25	30	10	CI12-90-DT8	63	37	30	10
-	-	-	-	-	CI12-90-DT12	68	36	38	10
-	-	-	-	-	CI16-90-DT8	63	37	30	10
CI16-DT12	44	24	40	10	CI16-90-DT12	68	36	38	10

*NOTE: dimensions are in mm

- Deflects water from connector**
 During high pressure cleaning
- High pull-off strength**
 Conduit corrugations sit tightly into interface junction
- Integral overcentre facility**
 Holds conduit securely in place during harness fabrication
- Conduit size labels**
 Each junction indicates nominal conduit size to aid installation
- Straight or 90° elbow versions**
 Compact design ideal for use where space is limited



Deutsch - DTP04 Series External Hinged Connector Interfaces



Description

Single compact 90° elbow fitting providing a dual orientation high integrity connection between the Deutsch DTP04 and Harnessflex conduit systems.

These fittings are designed to snap together over all types of slit and unslit conduit thus maintaining maximum conduit bore.

The 16-90-DTP04 adaptor will snap into the outlet of a 16mm hinged fitting including types 'Y' (YPS), 'T' (TPS), elbows (EPS) and joiners (JPS).

For connector part no's. look up table see page 71.

Deutsch DTP04 interfaces

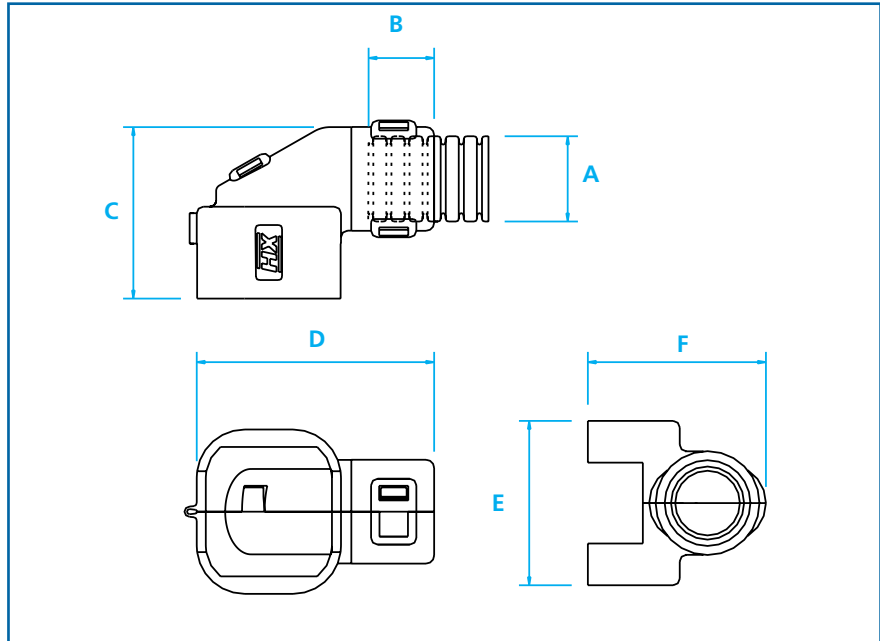

Nominal dimensions (Deutsch DTP04)

Part Number	Conduit size A		Nominal Dimensions (mm)				
	(NC)	(NW)	B	C	D	E	F
CI12-90-DTP04	12	7.5	10	27	37	25	28
16-90-DTP04	-	-	-	27	35	25	27

**NOTE: dimensions are in mm*



Deutsch - DRC50 External Connector Interfaces

Deutsch DRC50 interfaces

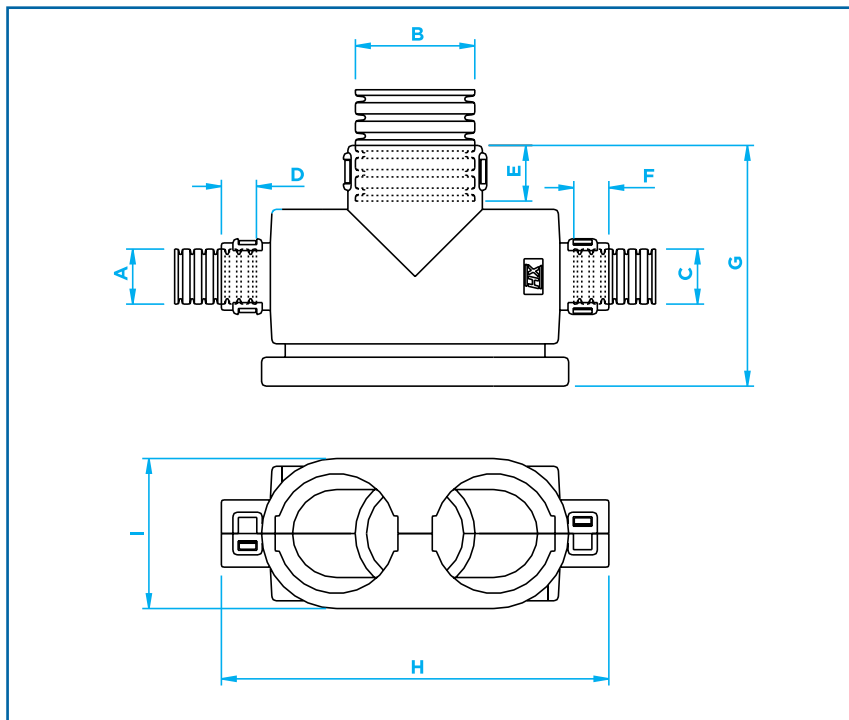

Description

Two identical half shells snap together onto the twin outlets of the Deutsch DRC50 interface giving a 3-way conduit fitting.

These fittings are designed to snap together over all types of slit and unslit conduit thus maintaining maximum conduit bore.

Nominal dimensions (Deutsch DRC50)

	Conduit sizes (NC)			(NW)			Nominal Dimensions (mm)					
	A	B	C	A	B	C	D	E	F	G	H	I
CI121212-DRC50	12	12	12	10	10	10	8	8	8	50	92	36
CI122812-DRC50	12	28	12	10	23	10	8	10	8	58	92	36
CI201220-DRC50	20	12	20	17	10	17	10	8	10	50	92	36
CI202820-DRC50	20	28	20	17	23	17	10	10	10	58	92	36
CI251225-DRC50	25	12	25	22	10	22	10	8	10	50	92	36
CI252825-DRC50	25	28	25	22	23	22	10	10	10	58	92	36

*NOTE: dimensions are in mm



FCI Automotive Apex Hinged Interfaces



FCI Automotive Apex Interfaces

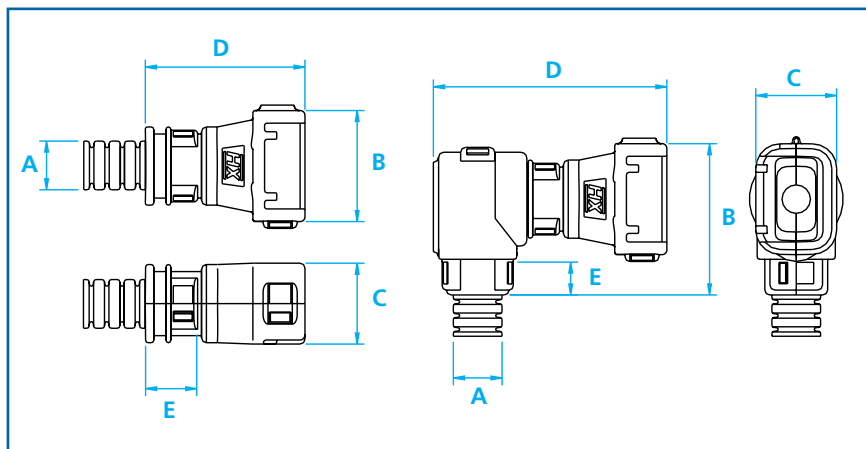

Description

Single junction, straight and 90° elbow fittings providing high integrity connections between FCI Apex connectors or Junior timer connectors and Harnessflex conduit systems.

These fittings are designed to snap together over all types of slit and unslit conduit thus maintaining maximum conduit bore.

In addition, 90° elbow versions allow the conduit to swivel 360° around the connector housing, sufficient to avoid the problems associated with one-piece interfaces of overflexing due to movement or vibration.

For connector part no's. look up table see page 71.

Nominal dimensions (FCI)

Part No. Straight Interface	B	C	D	E	Part No. 90° Elbow Swivel Interface	B	C	D	E
CI08-FCI02	25	17	33	12	CI08-90-FCI02	31	19	48	10
CI08-FCI03	34	17	34	12	CI08-90-FCI03	35	19	49	10
CI08-FCI04	39	17	34	12	CI08-90-FCI04	38	19	49	10
CI12-FCI02	25	17	27	7	CI12-90-FCI02	32	19	48	10
CI12-FCI03	35	17	29	7	CI12-90-FCI03	37	19	49	10
CI12-FCI04	38	17	29	7	CI12-90-FCI04	38	19	49	10
CI12-FCI14	53	26	34	10	CI08-90-FCI14	38	24	57	10
CI16-FCI14	53	26	59	10	CI12-90-FCI14	38	24	57	10
16-FCI14	53	26	33	n/a	CI16-90-FCI14	38	24	57	10
CI17-FCI10	39.2	25.5	44	10.6	CI08-90-FCS02	30	19	33	10
CI25-FCI50	56	37	50.7	13					

*NOTE: dimensions are in mm



Bosch Compact External Hinged Connector Interfaces

External connector interface dimensions

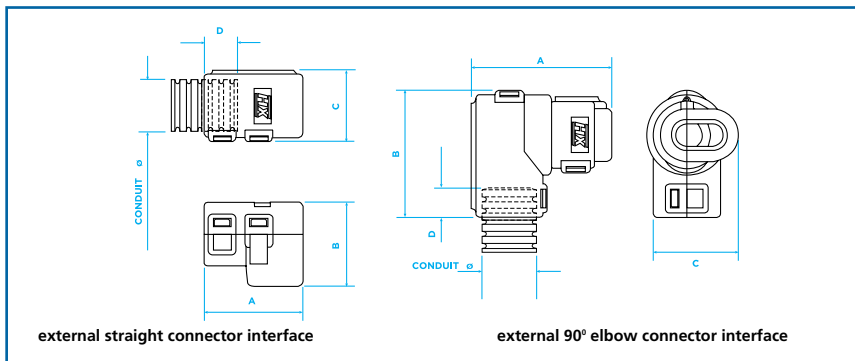

Configurations/part numbers (BOSCH Compact)

Part No. Straight Interface	Part No. 90° Elbow Swivel Interface	Conduct Size (NC)	Conduct Size (NW)	Connector Ref
CI08-BC2	CI08-90-BC2	08	7.5	2-way
CI08-BC3	CI08-90-BC3	08	7.5	3-way
CI08-BC4	CI08-90-BC4	08	7.5	4-way
CI12-BC2	CI12-90-BC2	12	10	2-way
CI12-BC3	CI12-90-BC3	12	10	3-way
CI12-BC4	CI12-90-BC4	12	10	4-way
CI28-BC40	-	28	23	40-way

*NOTE: dimensions are in mm

Nominal dimensions (BOSCH Compact)

Part No. Straight Interface	Part No. 90° Elbow Swivel Interface				Part No. Straight Interface	Part No. 90° Elbow Swivel Interface			
	A	B	C	D		A	B	C	D
CI08-BC2	25	21.3	18	10	CI08-90-BC2	33.3	30.3	20.5	10
CI08-BC3	25	26.7	18	10	CI08-90-BC3	33.3	30.3	26.7	10
CI08-BC4	25	29	18	10	CI08-90-BC4	37	30.3	33	10
CI12-BC2	25	21.3	18	10	CI12-90-BC2	33.3	30.3	20.5	10
CI12-BC3	25	26.7	18	10	CI12-90-BC3	33.3	30.3	26.7	10
CI12-BC4	25	29	18	10	CI12-90-BC4	37	30.3	33	10
CI28-BC40	44.4	40	-	-	-	-	-	-	-

*NOTE: dimensions are in mm

Description

Single junction, straight and 90° elbow fittings providing high integrity connections between various Bosch compact connectors and Harnessflex conduit systems.

These fittings are designed to snap together over all types of slit and unslit conduit thus maintaining maximum conduit bore.

In addition, 90° elbow versions allow the conduit to swivel 360° around the connector housing, sufficient to avoid the problems associated with one-piece interfaces of overflexing due to movement or vibration.

For connector part no's. look up table see page 71.

- **Deflects water from connector**
During high pressure cleaning
- **High pull-off strength**
Conduit corrugations sit tightly into interface junction
- **Integral overcentre facility**
Holds conduit securely in place during harness fabrication
- **Conduit size labels**
Each junction indicates nominal conduit size to aid installation
- **Straight or 90° elbow versions**
Compact design ideal for use where space is limited

Delphi Series External Hinged Connector Interfaces

External connector interface dimensions

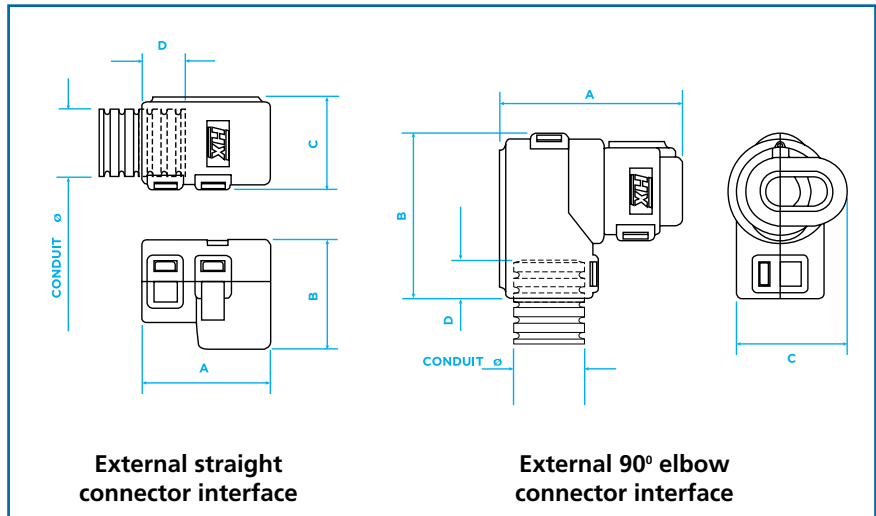

Description

Single junction, straight and 90° elbow fittings providing high integrity connections between various Delphi series connectors and Harnessflex conduit systems.

These fittings are designed to snap together over all types of slit and unslit conduit thus maintaining maximum conduit bore.

In addition, 90° elbow versions allow the conduit to swivel 360° around the connector housing, sufficient to avoid the problems associated with one-piece interfaces of overflexing due to movement or vibration.

For connector part no's. look up table see page 71.

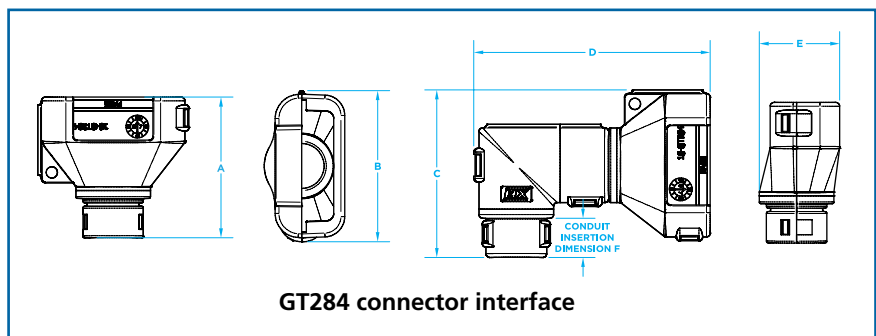
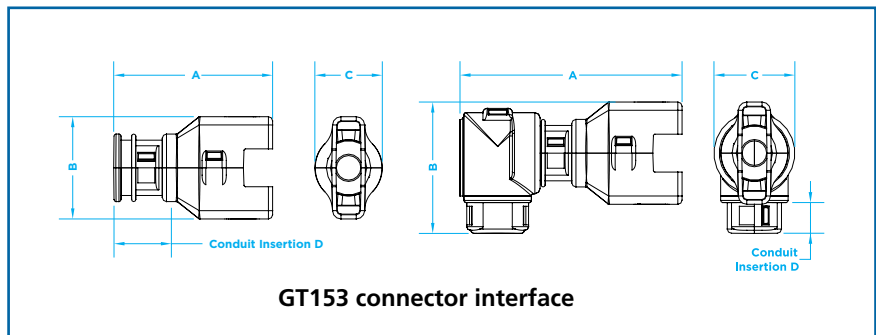

External Hinged Connector Interfaces

Configurations/part numbers (Delphi Metripack)

Part no. straight interface	Part no. 90° elbow swivel interface	Conduct Size (NC)	Conduct Size (NW)	Connector Type
CI08-DE001	CI08-90-DE001	08	7.5	2-way
CI08-MP2	CI08-90-MP2	08	7.5	2-way
CI08-MP3	CI08-90-MP3	08	7.5	3-way
C108-MMP2	C108-90-MMP2	08	7.5	2-way
	CI12-90-MP2	12	10	2-way
	CI12-90-MP3	12	10	3-way
	CI12-90-MMP3	12	10	2-way
CI08-WP2	CI08-90-WP2	08	7.5	2-way
	CI12-90-WP2	12	10	2-way
CI08-PTD2	CI08-90-PTD2	08	7.5	2-way
	CI12-90-PTD2	12	10	2-way
CI08-GT153	CI08-90-GT153	08	7.5	-
	CI12-90-GT153	12	10	-
12-GT284	CI12-90-GT284	12	10	-
16-GT284	CI16-90-GT284	16	13	-

*NOTE: dimensions are in mm



Nominal dimensions

Part No. Straight Interface	A	B	C	D	Part No. 90° Elbow Swivel Interface	A	B	C	D
CI08-MP2	20	16	28.9	12.3	CI08-90-MP2	35	42	29.5	7.3
CI08-MP3	43	20	28	10	CI08-90-MP3	56.9	30	20	10
CI08-MMP2	30	17	18	10	CI08-90-MMP2	45	30	19	7.3
	-	-	-	-	CI12-90-MP2	20	42	30.5	7.3
	-	-	-	-	CI12-90-MP3	56.9	31	20	10
	-	-	-	-	CI12-90-MMP2	-	-	-	-
CI08-WP2	31.3	16.1	28.3	10	CI08-90-WP2	45.2	33.3	19.5	10
	-	-	-	-	CI12-90-WP2	45.2	34.3	19.5	10
CI08-PTD2	20.2	20.5	18	14.7	CI08-90-PTD2	33.8	30	22	10
	-	-	-	-	CI12-90-PTD2	33.8	21	22	10
CI08-GT153	38	24	16	10	CI08-90-GT153	53	31	19	7
	-	-	-	-	CI12-90-GT153	53	32	19	10
12-GT284	37.3	21.3	40	29.5	CI12-90-GT284	62.6	44.4	-	10
16-GT284	37.3	21.3	40	29.5	CI16-90-GT284	62.6	44.4	-	-

*NOTE: dimensions are in mm

Part Ref.	Connector System	
MP	Delphi Metri-Pack	To suit Metripack
MMP	Delphi Metri-Pack	To suit Metripack
WP	Delphi Weatherpack	To suit Weatherpack
PTD	Power Timer	
GT	Delphi Metri-Pack Series 150 and 180	

For connector part no's. look up table see page 71.

Molex MX 93286 Series External Split Connector Interfaces



Description

Split type customised interface fittings providing high integrity connections to the Molex 93286 series of connectors and Harnessflex conduit systems.

The system offers connections to all types of slit and un-slit Harnessflex conduit systems multiple configurations both straight and at right angles to the connector to offer the maximum flexibility and space utilisation for harness design.

Additionally using the male type fitting the interface can be connected to Harnessflex hinged JPS, EPS, YPS and TPS fitting for multiple cable configuration outlet options.

The interfaces provide a cable routing solution whilst also offering mechanical, abrasion and jet washing protection for both the connector and cabling.

External connector interface dimensions

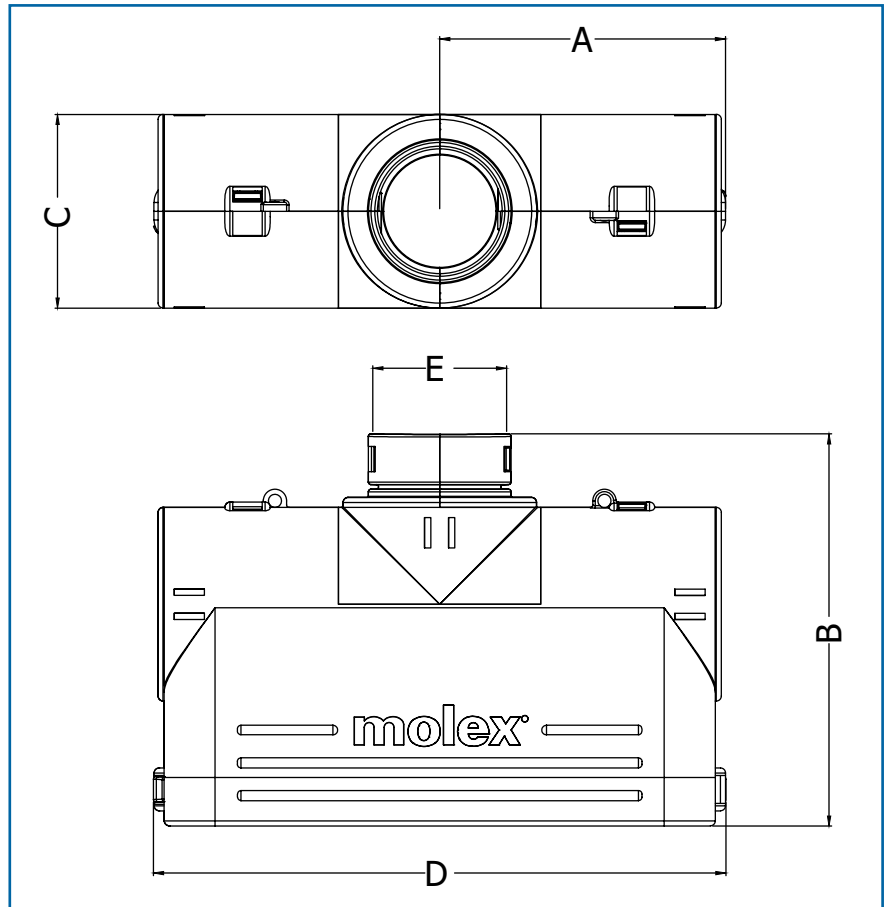

Configurations/part numbers

Part No straight interface	Part No 90° elbow interface	Conduit Size (E)	
		NC	NW
M28-MX93286	M28-90-MX93286	-	-
CI28-MX93286	CI28-90-MX93286	28	23
CI32-MX93286	CI32-90-MX93286	32	29
CI40-MX93286	CI40-90-MX93286	40	36

*NOTE: dimensions are in mm **NOTE: other configurations available on request

Part No straight interface	A	B	C	D
M28-MX93286	56.6	77.5	38.3	113.2
CI28-MX93286	56.6	77.5	38.3	113.2
CI32-MX93286	56.6	77.5	38.3	113.2
CI40-MX93286	56.6	83.3	46.8	113.2

*NOTE: dimensions are in mm **NOTE: other configurations available on request

90° External connector interface dimensions

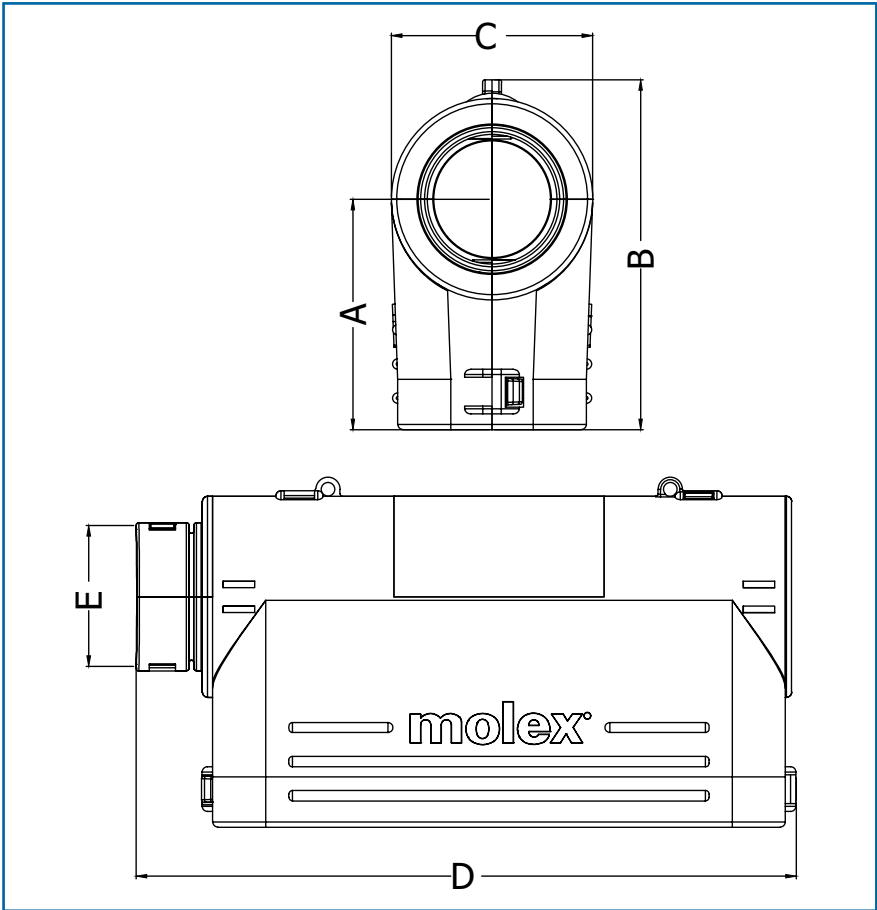

Configurations/part numbers

Part No 90° elbow interface	A	B	C	D
M28-90-MX93286	43.8	66.6	38.3	125.6
CI28-90-MX93286	43.8	66.6	38.3	125.6
CI32-90-MX93286	43.8	66.6	38.3	125.6
CI40-90-MX93286	43.8	68.5	46.8	131.4

*NOTE: dimensions are in mm **NOTE: other configurations available on request

- 1 Split external design**
Unrestricted bore and quick assembly no tools required
- 2 Multiple Configuration options**
Provides the right conduit and outlet position option
- 3 High strength**
Provides protection and security for connector and cable outlet options without the need for short conduit joints



Kostal Hinged Interfaces

External connector interface dimensions

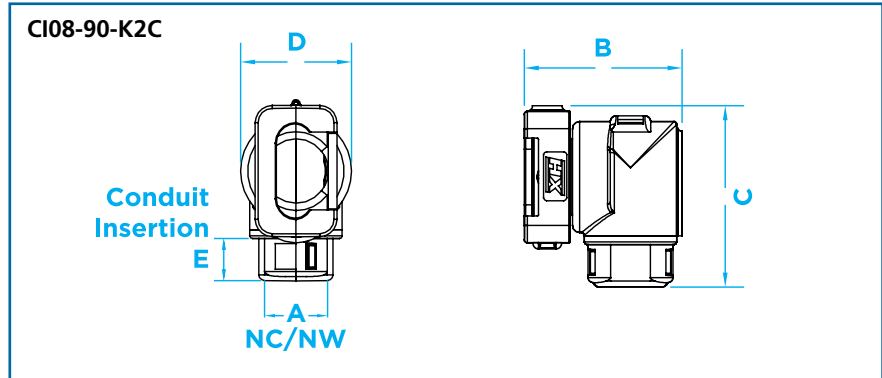

Configurations/part numbers (Kostal Interface)

Part No. 90° Elbow Swivel Interface	Conduit Size (A)		B	C	D	E
	(NC)	(NW)				
CI08-90-K2C	08	7.5	27.4	30	19.5	10
CI08-90-K3C	08	7.5	27.4	31.4	19.5	10
CI12-90-K2C	12	10	27.4	31	19.5	10
CI12-90-K3C	12	10	27.4	32.4	19.5	10

*NOTE: dimensions are in mm

Description

Clip-on elbow interface for Kostal in-line connector.

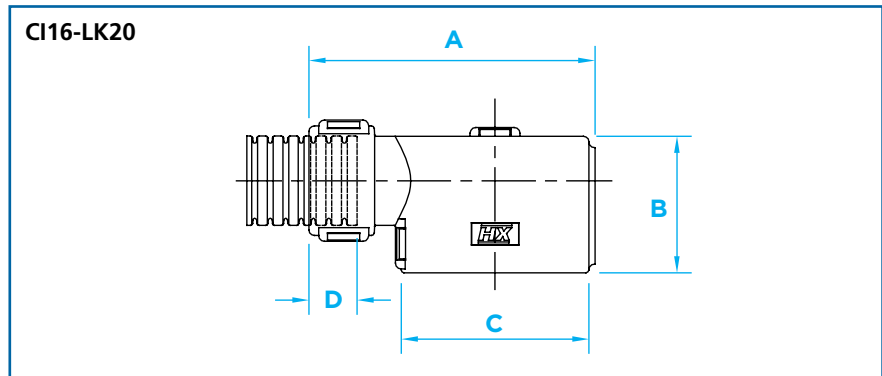

Nominal dimensions (Kostal Interface)

Part No. Straight Interface	Conduit Size (A)		B	C	D	E
	(NC)	(NW)				
CI16-LK20	16	13	51	28	34	10

*NOTE: dimensions are in mm

Nominal dimensions (PG Thread LK20)

Part No.	Thread Type	Thread Length	A/F	I.D
PG21-LK20	PG21	12.2	37.8	22.6

*NOTE: dimensions are in mm

Millflex Hinged ABS Interfaces

External connector interface dimensions

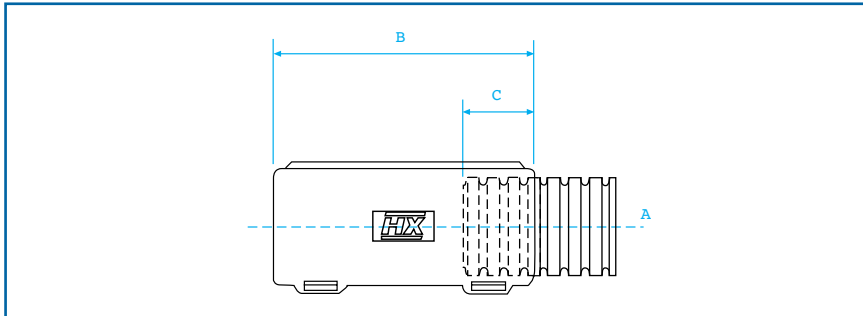

Nominal dimensions

Part No.	conduit A		dimensions	
	(NC)	(NW)	B	C
CI08-MF2	8	7.5	35.6	10
CI10-MF2	10	8.5	35.6	10
CI12-MF2	12	10	35.6	10

*NOTE: dimensions are in mm



Description

Clip-on straight interface for Millflex ABS connectors.

Sumitomo Hinged Interface

Interface dimensions

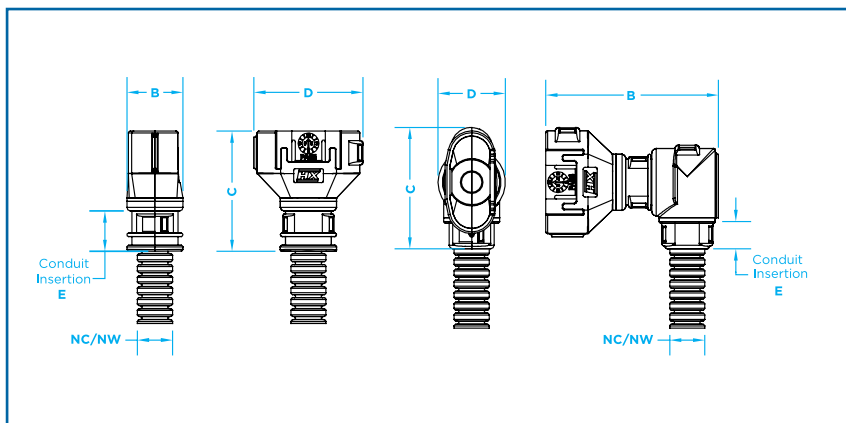

Nominal dimensions

Sumitomo 4 way

Part No.	Conduit Size		Dimensions			
	(NC)	(NW)	B	C	D	E
CI08-SU4	08	7.5	16.2	29.4	35.0	12.3
CI08-90-SU4	08	7.5	48.2	19.6	34.4	7.3

*NOTE: 180° versions are available **NOTE: dimensions are in mm



Description

Single junction, straight and 90° elbow fittings providing high integrity connections between Sumitomo connectors and Harnessflex conduit systems.

These fittings are designed to snap together over all types of slit and unslit conduit thus maintaining maximum conduit bore.

In addition, 90° elbow versions allow the conduit to swivel 360° around the connector housing, sufficient to avoid the problems associated with one-piece interfaces of overflexing due to movement or vibration.

DIN 72585 Hinged Interface

Interface dimensions

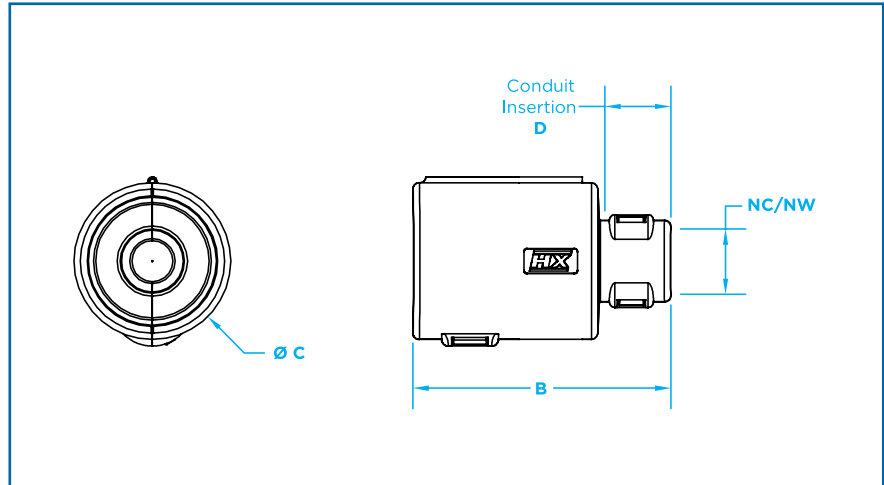

Description

Circular interface to fit DIN 72585 STYLE connectors.

Connector is free to swivel after interface is installed.

Nominal dimensions

Part No.	Conduit Size		Dimensions		
	(NC)	(NW)	B	C	D
CI08-72585	08	7.5	40.9	24.9	10
CI12-72585	12	10	40.9	24.9	10

*NOTE: dimensions are in mm

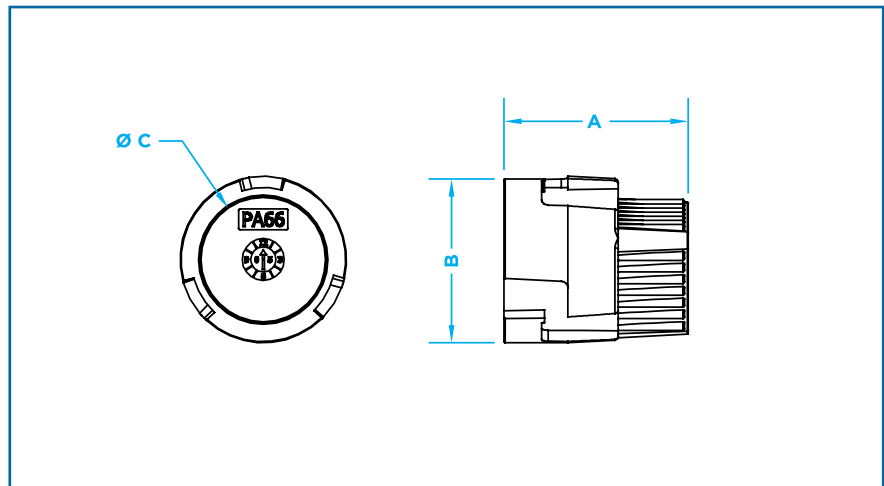

Description

Plastic IP67 blanking plug to seal female DIN 72585 circular connectors.

Prevents the ingress of water/dust, during transport or harness storage.

Part No.	Dimensions		
	A	B	C
BP72585	26.3	23.8	17.8

*NOTE: dimensions are in mm

Interfaces for Circular Connectors

Interface for circular connector configurations

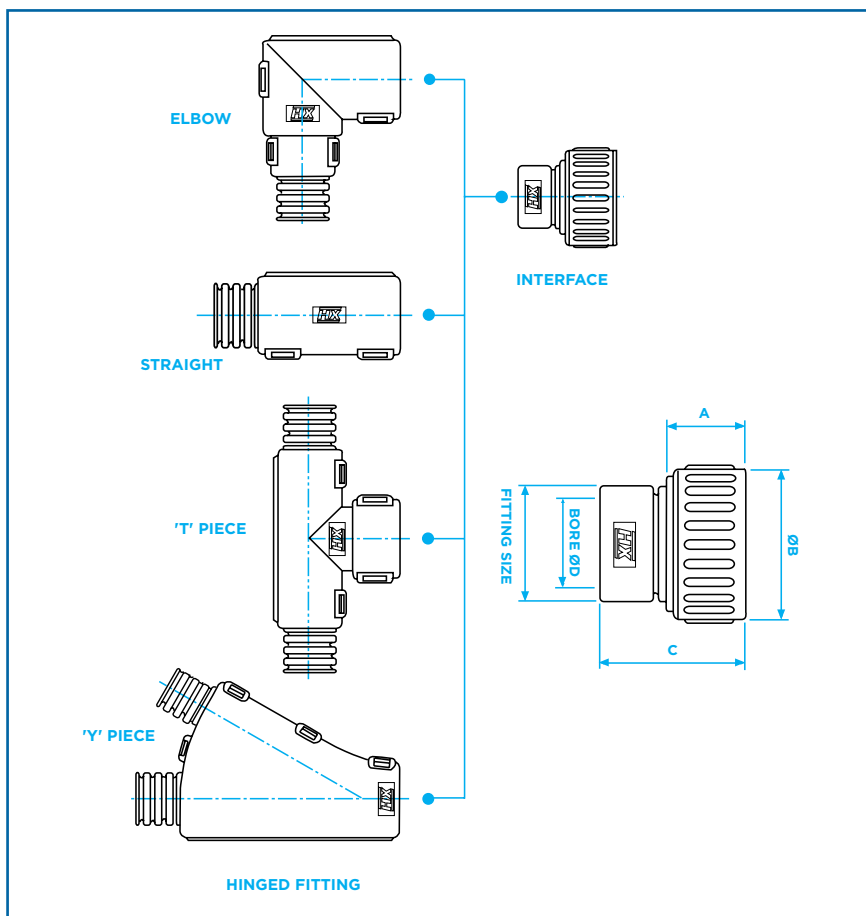

Description

Fitting provides connection between electrical circular connectors and hinged conduit system.

Due to the innovative design, the interface can freely rotate without any harness movement.

These fittings are designed to snap together over all types of slit and unslit conduit thus maintaining maximum conduit bore.

Hinged fitting

interface body	shell size	fitting size		thread size
		(NC)	(NW)	
NEPA14-16	14	16	13	13/16"-20 UNEF
NEPA16-20	16	20	17	15/16"-20 UNEF
NEPA24-28	24	28	23	1 7/16"-18 UNEF
CI20-CCU100	18/16	20	17	1"-20 UNEF
CI20-CCU119	18/16	20	17	1 3/16"-18 UNEF
CI28-CCU131	24	28	23	1 5/16"-18 UNEF
CI28-CCU138	24	28	23	1 3/8"-18 UNEF

*NOTE: dimensions are in mm

Interface for circular connector dimensions

interface body	shell size	fitting size		A	B	C	D
		(NC)	(NW)				
NEPA14-16	14	16	13	14.4	25.3	25.0	12.5
NEPA16-20	16	20	17	14.4	30.0	26.3	16.4
NEPA24-28	24	28	23	17.0	42.0	29.8	22.8
CI20-CCU100	18/16	20	17	11	30.0	26.0	16.4
CI20-CCU119	18/16	20	17	11	33.0	26.0	16.5
CI28-CCU131	24	28	23	13	41.5	30.0	22.8
CI28-CCU138	24	28	23	13	41.5	30.0	22.8

*NOTE: dimensions are in mm



Accessories

Multi-way Reducers

Description

One-piece, multi-way breakout inserts providing reducing options to a variety of conduit sizes from a single hinged fitting junction.

These reducers can accommodate all types of slit and unslit conduit and may be used with all Harnessflex hinged fittings.

Multi-way reducer configurations

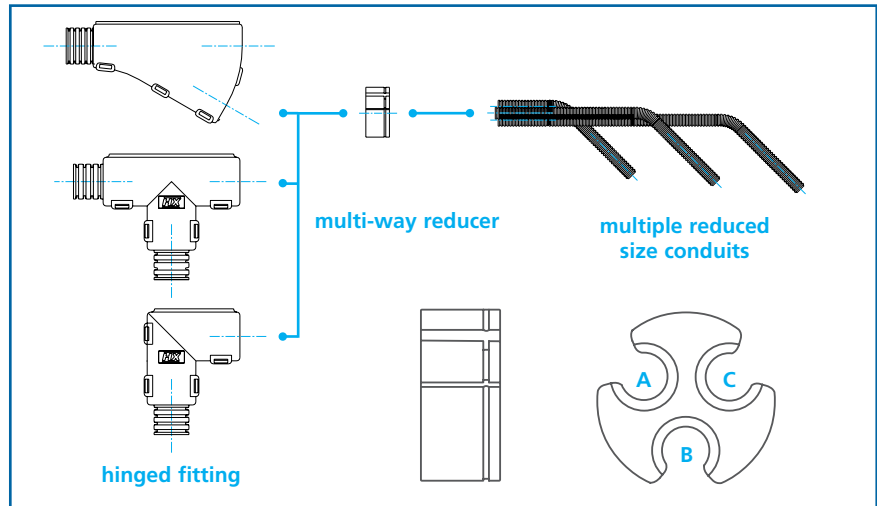

1 Full compatibility

Suitable for use with all Harnessflex hinged fittings

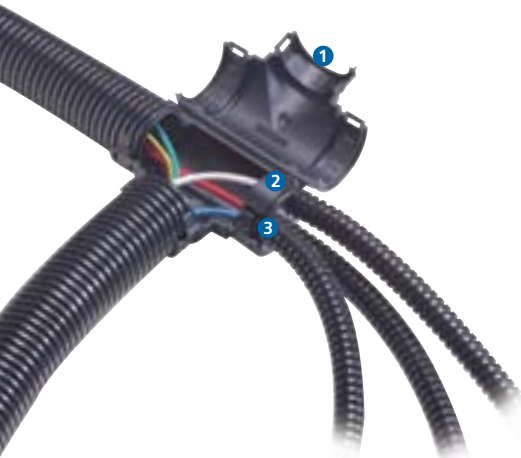

2 Overcentre facility

When used with external T-pieces the reducer is held securely in place during harness fabrication

3 High pull-off strength

Reducer sits tightly into hinged fitting junctions

Configuration/part numbers

Part No. Multi-way Reducer	From Conduit Size		To Conduit Size (NC)				To Conduit Size (NW)			
	(NC)	(NW)	A	B	C	D	A	B	C	D
ST20-2x08	20	17	8	8	-	-	7.5	7.5	-	-
ST20-12	20	17	12	-	-	-	10	-	-	-
STN25-3x08	20	22	8	8	8	-	7.5	7.5	7.5	-
ST25-12	20	22	12	8	-	-	10	-	-	-
ST25-1208	20	22	12	8	-	-	10	7.5	-	-
ST28-4x08	20	23	8	8	8	8	7.5	7.5	7.5	7.5
ST30-4x08	30	26	8	8	8	-	7.5	7.5	7.5	7.5
ST32-4x08	32	29	8	8	8	-	7.5	7.5	7.5	7.5

Blanking caps



Part No.	Conduit Size	
	(NC)	(NW)
BPST08	8	7.5
BP08	8	7.5
BP20	20	17

*NOTE: dimensions are in mm

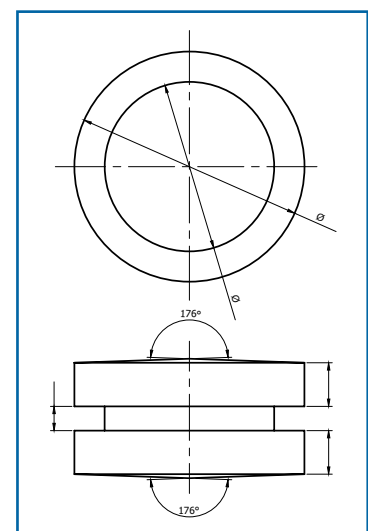

Sealed Fittings

Sealed Fittings

A wide range of sealed fittings rated at IP66, 67, 68 (2 bar 30 mins) & 69K are available and complete the product offering for vehicle wiring applications.

Quality & Standards

Manufacturing is controlled in accordance with BS EN ISO 9001 whilst ongoing testing & approval to international standards, eg: UL recognition, TUV & LCIE, provides any additional confidence required to specify appropriate Harnessflex products across the widest variety of automotive applications including hazardous or aggressive environments.

All components comply with End of Life Vehicle (ELV) directive EU2000/53/EC. Harnessflex also comply to ISO14001 - Environmental Standard

Capabilities

Through our internal design team we are able to offer unique solutions, specific to our customers applications. Using the latest 3D CAD modelling software we are able to communicate new product designs quickly and efficiently.

Rapid prototype parts can be made to order to enable product evaluation early on in the design cycle.

If you have a requirement for a dedicated sealed fitting please contact us to discuss your requirements.

Hints & Tips

1. The anti-vibration spring clips can be released easily if access is needed - no tool required.
2. In order to maintain the IP rating of the sealed fittings face sealing washers must be used with all threaded fittings.
3. By using an SC swivel clamping ring (page 61), an IP40 rotating joint can be achieved.
4. Our sealed T & X pieces and our sealed manifolds have inspection covers, which can be removed during installation to aid cable routing.



Straight Fittings



Description

Straight compression type fittings incorporating fixed or swivel male threads to provide connection to knockouts and threaded entries.

These fittings are designed for use with all types of slit and unslit conduit thus maintaining maximum conduit bore.

See page 58 for details on reducing options which enable each straight fitting to accommodate a variety of conduit sizes.

Order fitting bodies, cap nuts and sealing bushes separately.

Straight fitting configurations

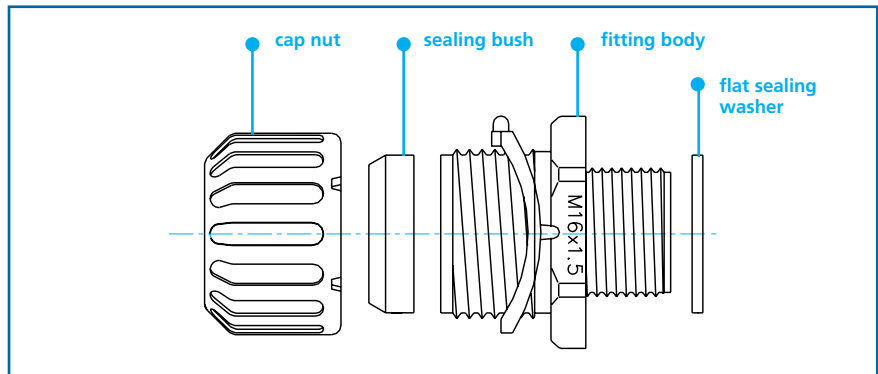

Straight fitting dimensions

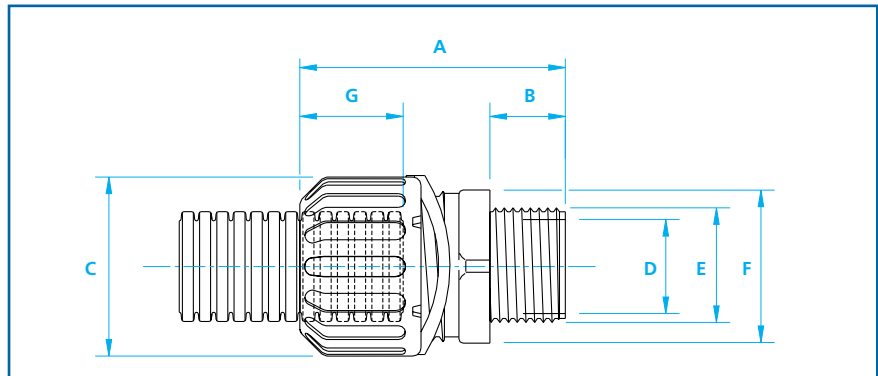

Straight swivel fitting dimensions

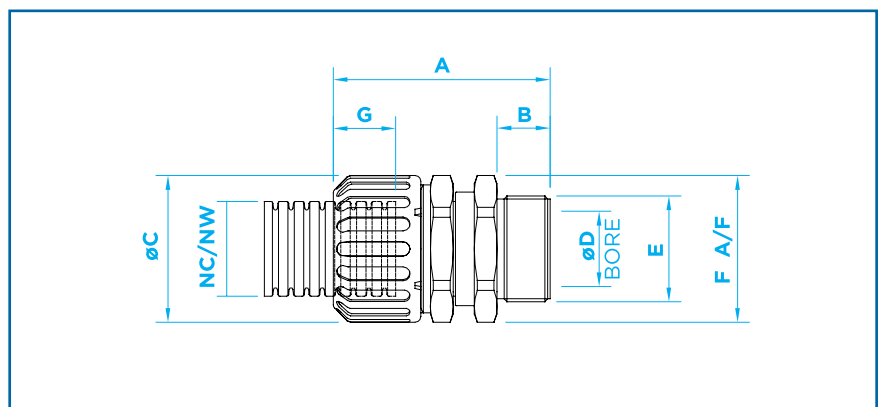

1 IP66/67/68 Sealing bush

Protects against ingress of water and dust

2 Cap-nut retention ring

Ensures integrity of assembly under extreme vibration (suits NC10-32 size fittings)

3 Choice of threads

Available with metric, PG fixed male threads, NPT & PF

4 Includes flat seal washer

Provides seal between panel/bulkhead and fitting

note: order fitting bodies, cap nuts and sealing bushes separately

Other thread options available including PF, PG, NPT and UNEF - contact us for further information.

Configurations/part numbers (metric versions)

Part No. Fitting Body	Cap Nut	Sealing Bush	Conduit Sizes		Thread Size
			(NC)	(NW)	
AB12-M16	CN07	SRN07	10	8.5	M16x1.5
AB12-M20	CN07	SRN07	10	8.5	M20x1.5
AB12-M16	CN09	SRN09	12	10	M16x1.5
AB12-M20	CN09	SRN09	12	10	M20x1.5
AB16-M16	CN11	SRN11	16	13	M16x1.5
AB16-M20	CN11	SRN11	16	13	M20x1.5
AB20-M20	CN16	SRN16	20	17	M20x1.5
AB25-M25	CN21	SRN21	25	22	M25x1.5
AB25-M25	CN28	SRN28	28	23	M25x1.5
AB32-M32	CN32	SRN29	32	29	M32x1.5
AB40-M40	CN36	SRN36	40	36	M40x1.5
AB50-M50	CN48	SRN48	50	48	M50x1.5

*NOTE: order fitting bodies, cap nuts and sealing bushes separately

Nominal dimensions (metric versions)

A	B	C	Min		A/F Size	
			Bore	Thread	F	G
34	12	23	11	M16x1.5	22	17
37	14	23	15	M20x1.5	27	17
34	12	26	11	M16x1.5	22	17
37	14	26	15	M20x1.5	27	17
35	12	26	11	M16x1.5	27	17
37	14	26	15	M20x1.5	27	11
39	14	31	15	M20x1.5	30	20
43	15	39	19	M25x1.5	38	21
43	15	39	19	M25x1.5	38	21
49	16	46	26	M32x1.5	46	27
59	16	58	31	M40x1.5	59	35
59	16	72	41	M50x1.5	73	35

*NOTE: dimensions are in mm and refer to an overall assembly

Configurations/part numbers (PG versions)

Part No. Fitting Body	Cap Nut	Sealing Bush	Conduit Sizes		Thread Size
			(NC)	(NW)	
AB12-PG09	CN07	SRN07	10	8.5	PG09
AB12-PG11	CN07	SRN07	10	8.5	PG11
AB12-PG13	CN07	SRN07	10	8.5	PG13.5
AB12-PG09	CN09	SRN09	12	10	PG09
AB12-PG11	CN09	SRN09	12	10	PG11
AB12-PG13	CN09	SRN09	12	10	PG13.5
AB16-PG09	CN11	SRN11	16	13	PG09
AB16-PG11	CN11	SRN11	16	13	PG11
AB16-PG13	CN11	SRN11	16	13	PG13.5
AB20-PG16	CN16	SRN16	20	17	PG16
AB25-PG21	CN21	SRN21	25	22	PG21
AB25-PG21	CN28	SRN28	28	23	PG21
AB32-PG29	CN32	SRN32	32	29	PG29
AB40-PG36	CN36	SRN36	40	36	PG36
AB50-PG48	CN48	SRN48	50	48	PG48

*NOTE: order fitting bodies, cap nuts and sealing bushes separately

**Part numbers for NPT and PF threads available on request

Nominal dimensions (PG versions)

A	B	C	Min		A/F Size	
			Bore	Thread	F	G
32	10	23	10	PG09	22	17
32	10	23	14	PG11	22	17
32	10	23	16	PG13.5	22	17
32	10	23	10	PG09	22	17
32	10	23	14	PG11	22	17
32	10	26	16	PG13.5	27	17
32	10	26	10	PG09	27	17
32	10	26	14	PG11	27	17
32	10	26	16	PG13.5	27	17
35	11	31	18	PG16	30	20
40	12	39	23	PG21	38	21
40	12	39	23	PG21	38	21
45	12	46	31	PG29	46	27
55	12	58	38	PG36	59	35
55	12	72	50	PG48	73	35

*NOTE: dimensions are in mm and refer to an overall assembly

Configurations/part numbers (swivel metric versions)

Part No. Fitting Body	Cap Nut	Sealing Bush	Conduit Sizes		Thread Size
			(NC)	(NW)	
ABS12-M16	CN07	SRN07	10	8.5	M16x1.5
ABS12-M20	CN07	SRN07	10	8.5	M20x1.5
ABS12-M16	CN09	SRN09	12	10	M16x1.5
ABS12-M20	CN09	SRN09	12	10	M20x1.5
ABS16-M16	CN11	SRN11	16	13	M16x1.5
ABS16-M20	CN11	SRN11	16	13	M20x1.5
ABS20-M20	CN16	SRN16	20	17	M20x1.5
ABS25-M25	CN21	SRN21	25	22	M25x1.5
ABS25-M25	CN28	SRN28	28	23	M25x1.5
ABS32-M32	CN32	SRN29	32	29	M32x1.5

*NOTE: order fitting bodies, cap nuts and sealing bushes separately

**Other thread options available including PF, PG, NPT and UNEF - contact us for further information

Nominal dimensions (swivel metric versions)

A	B	C	Min		A/F Size	
			Bore	Thread	F	G
44.5	11	23	12	M16x1.5	24	17
44.5	11	23	12	M20x1.5	24	17
44.5	11	23	12	M16x1.5	24	17
44.5	11	23	12	M20x1.5	24	17
46.5	12	26	12	M16x1.5	30	20
44.5	11	26	12	M20x1.5	30	20
47	11	31	16	M20x1.5	33	22.5
52	12	39	19	M25x1.5	42.5	22.5
52	12	39	19	M25x1.5	42.5	22.5
58.5	17	46.5	26.5	M32x1.5	51	26

*NOTE: dimensions are in mm and refer to an overall assembly

90° elbows



Description

90° compression type fittings incorporating fixed or swivel male threads to provide connection to knockouts and threaded entries.

These fittings are designed for use with all types of slit and unslit conduit thus maintaining maximum conduit bore.

See page 58 for details on reducing options which enable each straight fitting to accommodate a variety of conduit sizes.

Order fitting bodies, cap nuts and sealing bushes separately.

90° elbow configurations

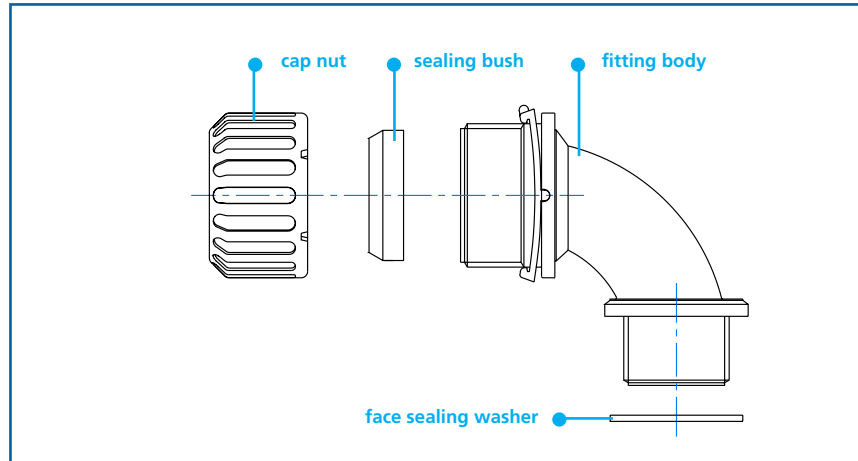

90° fitting dimensions

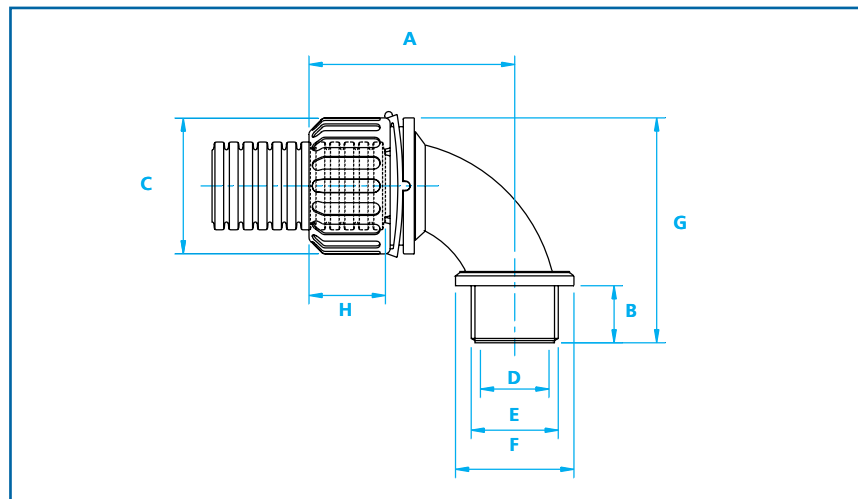

90° swivel fitting dimensions

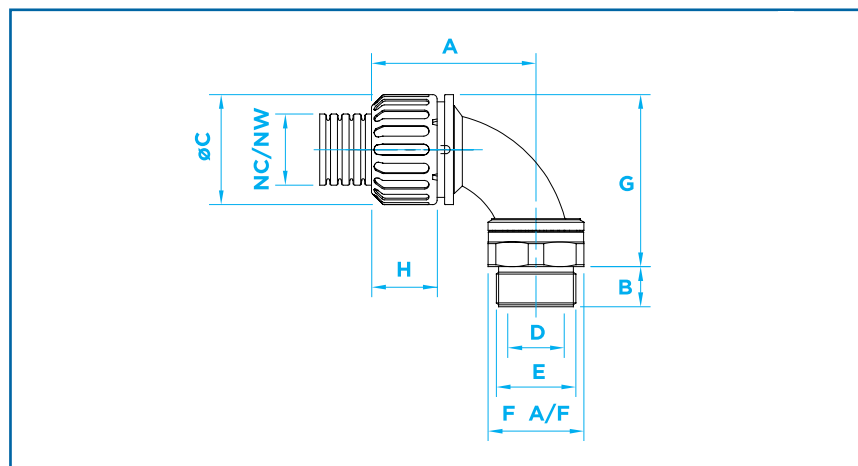

1 IP66, IP67 & IP68 Sealing

SRN sealing bush protects against ingress of water and dust

2 Cap-nut retention ring

Ensures integrity of assembly under extreme vibration (suits NC10-32 size elbows)

3 90° swept elbow

Avoids cable damage and abrasion

4 Choice of threads

Available with metric, PG fixed male threads and optional face sealing washer

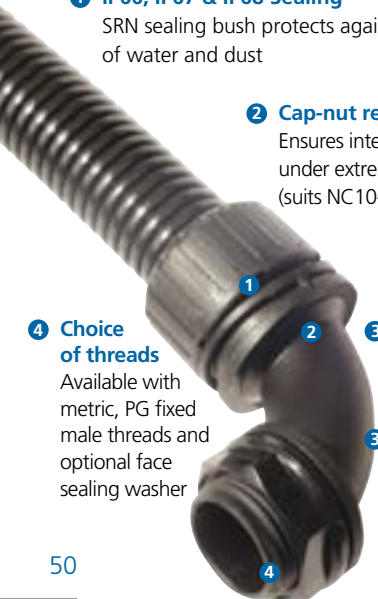

Configurations/part numbers (metric versions)

Part No. Elbow Body	Cap Nut	Sealing Bush	Face Sealing Sasher	Conduit Sizes		Thread Size
				(NC)	(NW)	
AB12-M16-90	CN07	SRN07	SWM16	10	8.5	M16x1.5
AB12-M16-90	CN09	SRN09	SWM16	12	10	M16x1.5
AB16-M16-90	CN11	SRN11	SWM16	16	13	M16x1.5
AB16-M20-90	CN11	SRN11	SWM20	16	13	M20x1.5
AB20-M20-90	CN16	SRN16	SWM20	20	17	M20x1.5
AB25-M25-90	CN21	SRN21	SWM25	25	22	M25x1.5
AB25-M25-90	CN28	SRN28	SWM25	25	23	M25x1.5
AB32-M32-90	CN32	SRN29	SWM32	32	29	M32x1.5
AB40-M40-90	CN36	SRN36	SWM40	40	36	M40x1.5
AB50-M50-90	CN48	SRN48	SWM50	50	48	M50x1.5

*NOTE: order elbow bodies, cap nuts, sealing bushes separately

Nominal dimensions (metric versions)

A	B	C	Min		F	G	H
			Bore	Thread			
46	12	23	11	M16x1.5	19	46	17
46	12	23	11	M16x1.5	19	46	17
46	12	26	15	M16x1.5	22	48	17
46	13	26	15	M20x1.5	27	49	17
47	13	31	15	M20x1.5	27	51	20
56	15	39	20	M25x1.5	33	62	21
56	15	39	20	M25x1.5	33	62	21
66	16	46	26	M32x1.5	40	76	27
77	16	59	34	M40x1.5	48	93	35
94	16	72	40	M50x1.5	59	114	35

*NOTE: dimensions are in mm and refer to an overall assembly

Configurations/part numbers (PG versions)

Part No. Elbow Body	Cap Nut	Sealing Bush	Face Sealing Sasher	Conduit Sizes		Thread Size
				(NC)	(NW)	
AB12-PG09-90	CN07	SRN07	SWPG09	10	8.5	PG09
AB12-PG09-90	CN09	SRN09	SWPG09	12	10	PG09
AB16-PG11-90	CN11	SRN11	SWPG11	16	13	PG11
AB16-PG13-90	CN11	SRN13	SWPG13	16	13	PG13.5
AB20-PG16-90	CN16	SRN16	SWPG16	20	17	PG16
AB25-PG21-90	CN21	SRN21	SWPG21	25	22	PG21
AB25-PG21-90	CN28	SRN21	SWPG21	28	23	PG21
AB32-PG29-90	CN32	SRN29	SWPG29	32	29	PG29
AB40-PG36-90	CN36	SRN36	SWPG36	40	36	PG36
AB50-PG48-90	CN48	SRN48	SWPG48	50	48	PG48

*NOTE: order elbow bodies, cap nuts, sealing bushes and face sealing washers separately

Nominal dimensions (PG versions)

A	B	C	Min		F	G	H
			Bore	Thread			
46	10	23	11	PG09	22	44	17
46	10	23	11	PG09	22	44	17
46	10	26	14	PG11	25	46	17
46	10	26	14	PG13.5	25	46	17
46	12	31	15	PG16	28	50	20
56	12	39	22	PG21	36	59	21
56	12	39	22	PG21	36	59	21
66	12	46	29	PG29	44	72	27
79	12	58	39	PG36	54	89	35
94	12	72	51	PG48	68	110	35

Configurations/part numbers (swivel metric versions)

Part No. Elbow Body	Cap Nut	Sealing Bush	Face Sealing Sasher	Conduit Sizes		Thread Size
				(NC)	(NW)	
ABS12-M16-90	CN07	SRN07	SWM16	10	8.5	M16x1.5
ABS20-M20-90	CN16	SRN16	SWM20	20	17	M20x1.5
ABS32-M32-90	CN32	SRN29	SWM32	32	29	M32x1.5
ABS50-M50-90	CN48	SRN48	SWM50	50	48	M50x1.5

*NOTE: order elbow bodies, cap nuts, sealing bushes and face sealing washers separately.

**Other thread options available including PF, PG, NPT and UNEF - contact us for further information.

Nominal dimensions (swivel metric versions)

A	B	C	Min		F	G	H
			Bore	Thread			
45	12	23	12	M16x1.5	24	45	17
46	12	26	12	M16x1.5	24	46	17
48	11	31	16	M20x1.5	27	48	20
56	12	39	19	M25x1.5	34	59	21
66	17	46	26	M32x1.5	42	71	27
76	18	59	35	M40x1.5	54	90	35
92	16	72	45	M50x1.5	70	112	35

90° flanges



Description

90° elbow compression type fittings providing a 4 hole panel mounting facility. These fittings are designed for use with all types of slit and unslit conduit thus maintaining maximum conduit bore.

See page 58 for details on reducing options which enable each straight fitting to accommodate a variety of conduit sizes.

Please note:

For extending the capability of sealed fittings, consult us for the following: clamping rings, end sleeves/end caps, grommet seals, locknuts, face sealing washers, thread reducers/enlargers.

90° flange configurations and nominal dimensions

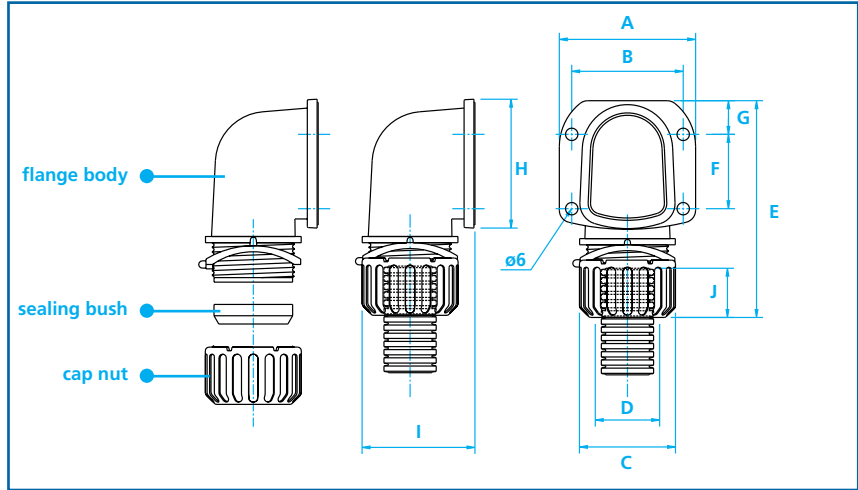

Configurations/part numbers (metric versions)

Part No.	Flange Body	Cap Nut	Sealing Bush	Conduit Sizes (NC)	Conduit Sizes (NW)
AB32-F90		CN32	SRN29	32	29
AB40-F90		CN36	SRN36	40	36
AB50-F90		CN48	SRN48	50	48

*NOTE: order flange bodies, cap nuts and sealing bushes separately

Nominal dimensions

Part No.	Min Bore										
Flange Body	A	B	C	D	E	F	G	H	I	J	
AB32-F90	66	54	46	36	95	36	17	63	53	27	
AB40-F90	86	73	63	46	115	30	27	77	64	35	
AB50-F90	86	73	73	59	125	30	30	86	77	35	

*NOTE: dimensions are in mm and refer to an overall assembly

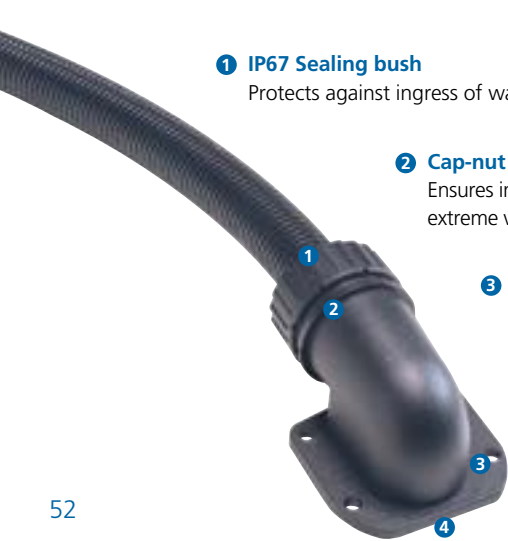

1 IP67 Sealing bush

Protects against ingress of water and dust

2 Cap-nut retention ring

Ensures integrity of assembly under extreme vibration (only NC32 size flange)

3 90° flange design

Avoids cable damage and abrasion

4 Integral O ring face seal

Provides seal between panel/bulkhead and fitting

T-Pieces

T-piece configurations and nominal dimensions

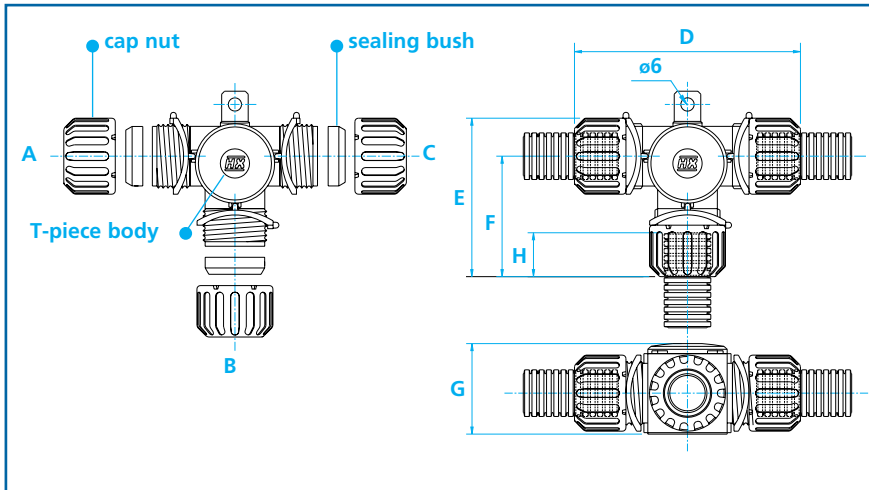

Description

Symmetrical, 3 junction compression type fittings providing a variety of conduit size configurations.

These fittings are designed for use with all types of slit and unslit conduit thus maintaining maximum conduit bore.

See page 58 for details on reducing options which enable each straight fitting to accommodate a variety of conduit sizes.

Accessories

For extending the capability of sealed fittings, consult us for the following: clamping rings, end sleeves/end caps, grommet seals, locknuts, face sealing washers, thread reducers/enlargers.

Order T-piece bodies, cap nuts and sealing bushes separately.

Configurations/part numbers

Part No. T-piece with bracket	Part No. T-piece no bracket	Cap Nut	Sealing Bush	Conduit Sizes (NC)			Conduit Sizes (NW)		
				A	B	C	A	B	C
-	TP12	CN07	SRN07	10	10	10	8.5	8.5	8.5
-	TP12	CN09	SRN09	12	12	12	10	10	10
-	TP16	CN11	SRN11	16	16	16	13	13	13
TPB20	TP20	CN16	SRN16	20	20	20	17	17	17
TPB28	TP28	CN21	SRN21	25	25	25	22	22	22
TPB28	TP28	CN28	SRN28	28	28	28	23	23	23
TPB32		CN32	SRN29	32	32	32	29	29	29

*NOTE: order T-piece bodies, cap nuts and sealing bushes separately

Nominal dimensions

Part No. T-piece with bracket	Part No. T-piece no bracket	D	E	F	G	H
-	TP12	68	50	39	27	17
-	TP16	69	51	38	31	17
TPB20	TP20	80	58	43	35	20
TPB28	TP28	95	71	52	43	21
TPB32		109	84	61	51	27

*NOTE: dimensions are in mm and refer to an overall assembly

- IP67 Sealing bush**
Protects against ingress of water and dust
- Cap-nut retention ring**
Ensures integrity of assembly under extreme vibration (only NC32 size flange)
- Smooth contoured internal form**
Protects cables from damage during installation
- Optional mounting bracket**
Provides external fixing for larger T-pieces
- Removable IP67 inspection lid**
Provides easy access to cables during installation



X-Piece



Description

Symmetrical 4 junction compression type fitting providing a variety of conduit size configurations.

These fittings are designed for use with all types of unslit conduit thus maintaining maximum conduit bore.

See page 58 for details on reducing options which enable each straight fitting to accommodate a variety of conduit sizes.

Accessories

For extending the capability of sealed fittings, consult us for the following: clamping rings, end sleeves / end caps, grommet seals, locknuts, face sealing washers, thread reducers / enlargers.

Order X-piece bodies, cap nuts and sealing bushes separately.

X-piece configurations and dimensions

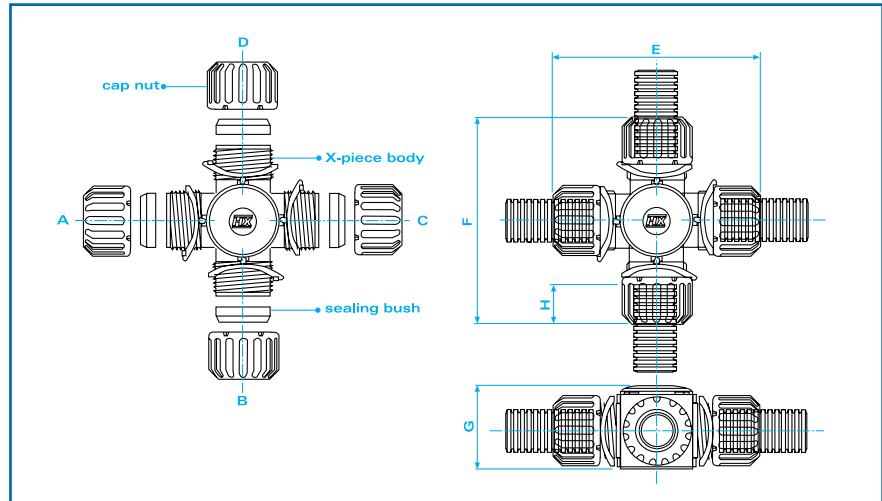

X-piece part numbers and dimensions

Part No.	Cap Nut	Sealing Bush	Conduit Sizes (NC)				Conduit Sizes (NW)			
			A	B	C	D	A	B	C	D
XP20	CN16	SRN16	20	20	20	20	17	17	17	17

*NOTE: order X-piece bodies, cap nuts and sealing bushes separately

Nominal dimensions

Part No.	E	F	G	H
XP20	80	80	35	20

*NOTE: dimensions are in mm



- 1 **IP67 Sealing bush**
Protects against the ingress of water and dust
- 2 **Cap-nut retention ring**
Ensures integrity of assembly under extreme vibration
- 3 **Smooth contoured internal form**
Protects cables from damage during installation
- 4 **Removable IP67 inspection lid**
Provides easy access to cables during installation
- **Full compatibility**
Suitable for use with all Harnessflex sealed fittings

Manifolds

Manifold configurations and dimensions

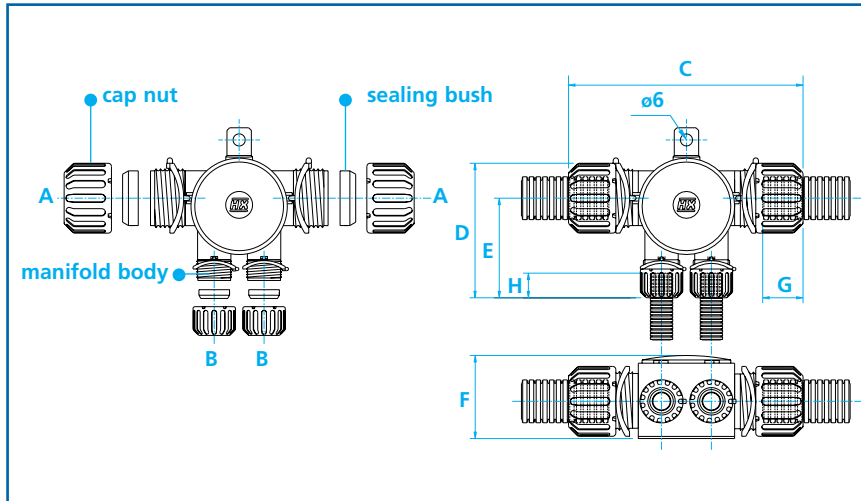

Description

Asymmetrical 4 junction compression fitting.

These fittings are designed for use with all types of unslit conduit thus maintaining maximum conduit bore.

Accessories

For extending the capability of sealed fittings, consult us for the following: clamping rings, end sleeves / end caps, grommet seals, locknuts, face sealing washers, thread reducers / enlargers.

Configurations/part numbers

Part No.	Cap Nut		Sealing Bush		Conduit Sizes (NC)		Conduit Sizes (NW)	
	A	B	A	B	A	B	A	B
TPM2512	CN21	CN07	SRN21	SRN07	25	10	22	8.5
TPM2512	CN21	CN09	SRN21	SRN09	25	12	22	10
TPM2512	CN28	CN07	SRN28	SRN07	28	10	23	8.5
TPM2512	CN28	CN09	SRN28	SRN09	28	12	23	10

*NOTE: order manifold bodies, cap nuts and sealing bushes separately

Nominal dimensions

Part No.	C	D	E	F	G	H
TPM2512	105	74	55	40	21	17

*NOTE: dimensions are in mm and refer to an overall assembly

Order manifold bodies, cap nuts and sealing bushes separately.

- 1 **IP67 Sealing bush**
Protects against the ingress of water and dust
- 2 **Cap-nut retention ring**
Ensures integrity of assembly under extreme vibration
- 3 **Smooth contoured internal form**
Protects cables from damage during installation
- 4 **Integral mounting bracket**
Provides secure external fixing point
- 5 **Removable IP67 inspection lid**
Provides easy access to cables during installation



Circular UNEF Connector Interfaces

Circular connector interface dimensions

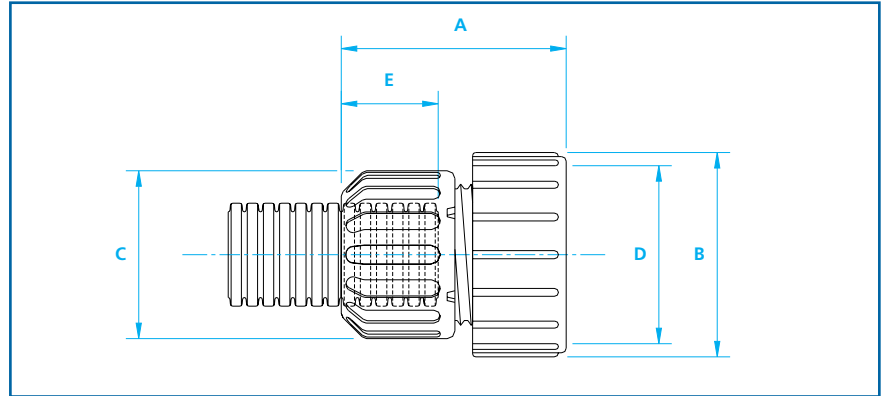

Description

Straight compression type fittings providing connection between military style circular connections and conduit systems.

These fittings are designed for use with all types of unslit conduit thus maintaining maximum conduit bore.

See page 58 for details on reducing options which enable each straight fitting to accommodate a variety of conduit sizes.

Accessories

For extending the capability of sealed fittings, consult us for the following: clamping rings, end sleeves/end caps, grommet seals, locknuts, face sealing washers, thread reducers/enlargers.

Order interface bodies, cap nuts and sealing bushes separately.

Specials available upon request, please contact our technical department for further details.

Configurations/part numbers

Part No.	Interface Body	Cap Nut	Sealing Bush	Face Sealing Washer	Conduit Sizes (NC)	Conduit Sizes (NW)	Thread Size
MPA01	CN07	SRN07	SWPG07	10	8.5	5/8"-24 UNEF	
MPA01	CN09	SRN09	SWPG07	12	10	5/8"-24 UNEF	
MPA03	CN16	SRN16	SWM20	20	17	1"-20 UNEF	
MPA04	CN16	SRN16	SWPG16	20	17	1 3/16"-18 UNEF	
MPA05	CN21	SRN21	SWM25	25	22	1 7/16"-18 UNEF	
MPA05	CN28	SRN28	SWM25	28	23	1 7/16"-18 UNEF	
MPA08	CN07	SRN07	SWPG09	10	8.5	3/4"-20 UNEF	
MPA08	CN09	SRN09	SWPG09	12	10	3/4"-20 UNEF	

**NOTE: order interface bodies, cap nuts, sealing bushes and sealing washers separately*

Nominal dimensions

Part No.	Interface Body	A	B	C	Thread Size	D	E
MPA01		30	24	23	5/8"-24 UNEF		17
MPA03		33	36	31	1"-20 UNEF		20
MPA04		32	37	31	1 3/16"-18 UNEF		20
MPA05		37	44	39	1 7/16"-18 UNEF		21
MPA08		30	32	23	3/4"-20 UNEF		17

**NOTE: dimensions are in mm and refer to overall assembly*

Solenoid Connector Interfaces

Solenoid interface dimensions

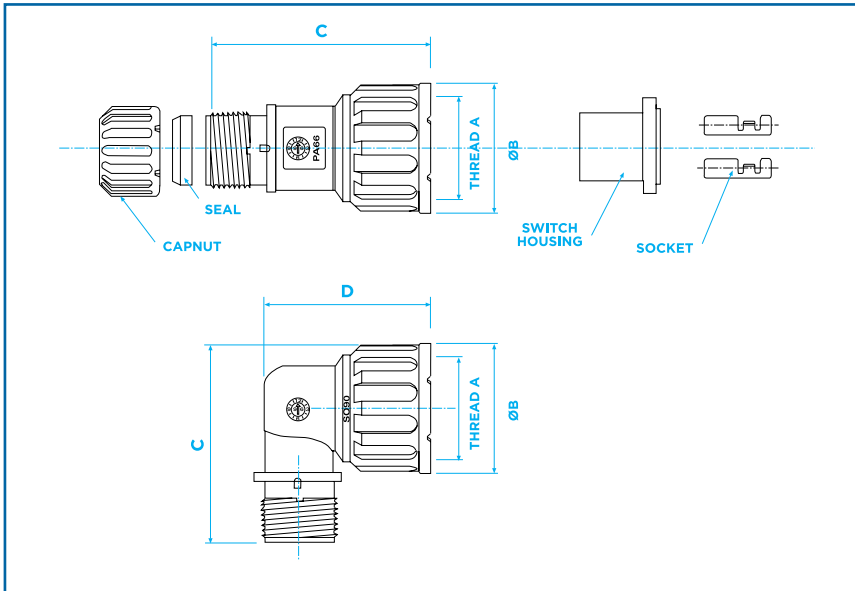

Description

Screw-thread straight and elbow connectable interfaces for circular solenoids, sensors and switches. These fittings are designed for use with all types of unslit conduit thus maintaining maximum conduit bore. See page 58 for details on reducing options which enable each straight fitting to accommodate a variety of conduit sizes.

Accessories

For extending the capability of sealed fittings, consult us for the following: clamping rings, end sleeves/end caps, grommet seals, locknuts, face sealing washers, thread reducers/enlargers.

Nominal dimensions

Part Number	Thread	Nominal Dimensions			Nut Colour
		A	B	C	
SC-M24-90	M24x1.0	31.3	8.5	40.5	Black
SC-M27-90	M27x1.0	34	40.4	0.5	Grey

*NOTE: dimensions are in mm

Part Number	Thread	Nominal Dimensions			Nut Colour
		A	B	C	
SC-M24-S	M24x1.0	31	53	-	Black
SC-M27-S	M27x1.0	34	54	-	Grey

*NOTE: dimensions are in mm

Part Number	Suitable for Connector Type	Number of Pins	Dimensions			
			A	B	C	D
RSG02	M27	2	25.0	3.5	18.7	23.0
RSG03	M27	3	25.3	3.5	18.0	21.0
RSG04	M27	4	25.3	3.5	18.7	23.0
RSG05	M24	2	22.5	3.5	18.0	23.0
RSG06	M24	3	22.3	3.5	18.0	21.0

*NOTE: dimensions are in mm

RSGP01 Socket Part No. (single) RSGP01 (chain form) RSGP01-C

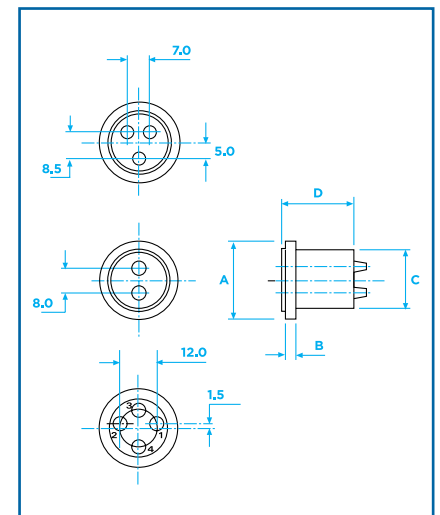
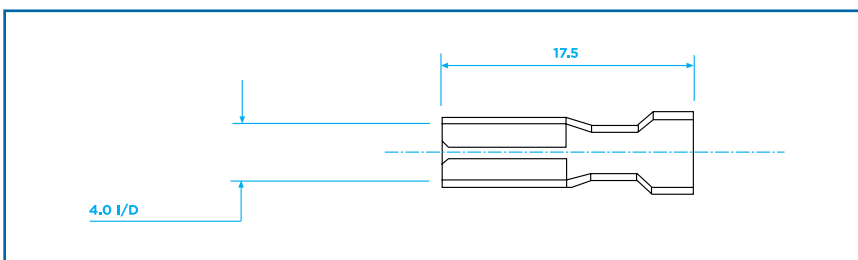

Reducing Bushes

Cap nut and reducing sealing bushes

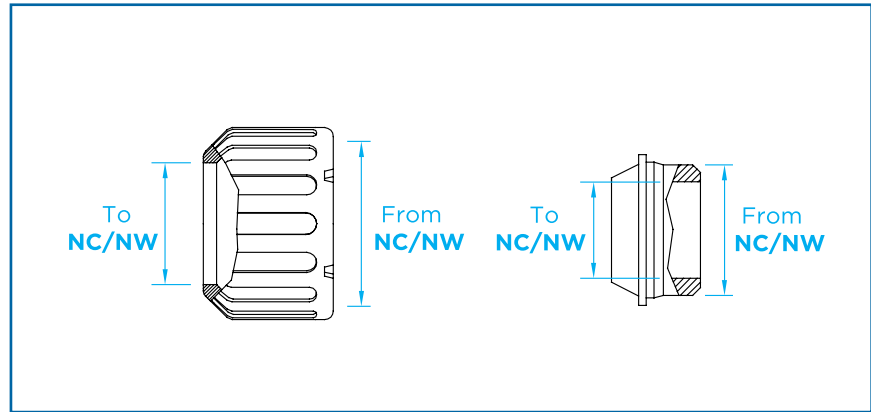

Configurations/nominal dimensions/part numbers

Part No.	Part No.	From Conduit Size		To Conduit Size	
		NC	NW	NC	NW
CN09-08	RSB12-08	12	10	08	7.5
CN11-08	RSB16-08	16	13	08	7.5
CN11-12	RSB16-12	16	13	12	10
CN16-08	RSB20-08	20	17	08	7.5
CN16-12	RSB20-12	20	17	12	10
CN16-16	RSB20-16	20	17	16	13
CN21-12	RSB25-12	25	22	12	10
CN21-16	RSB25-16	25	22	16	13
CN21-20	RSB25-20	25	22	20	17
CN21-12	RSB28-12	28	23	12	10
CN21-16	RSB28-16	28	23	16	13
CN21-20	RSB28-20	28	23	20	17
CN32-20	RSB32-20	32	29	20	17
CN32-25	RSB32-25	32	29	25	22
CN32-28	RSB32-28	32	29	28	23

*NOTE: dimensions are in mm

Cable Glands

Cable gland configurations

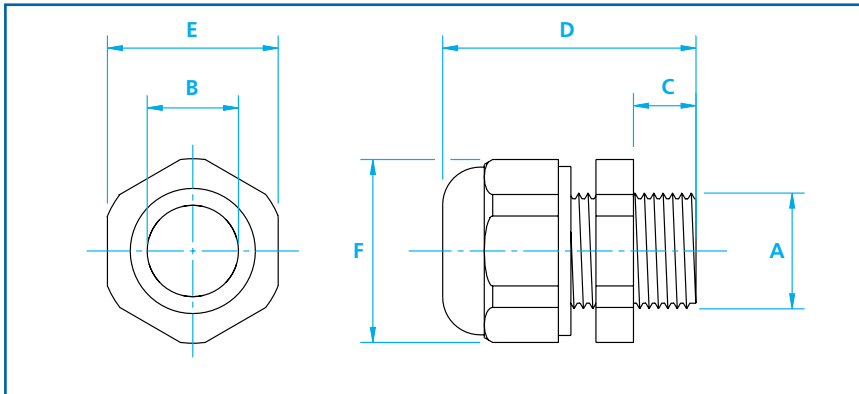

Configurations/nominal dimensions/part numbers (metric versions)

Part No.	Thread	Cable OD Range		A/F size		
	A	B	C	D	E	F
CGS-M16	M16x1.5	4.0 - 10.0	9	34.5	21	23.5
CGS-M20	M20x1.5	6.0 - 12.0	10	37	24	27
CGS-M25	M25x1.5	13.0 - 18.0	11	40	30	33
CGS-M32	M32x1.5	17.0 - 25.0	12	49	41	45.5
CGS-M40	M40x1.5	24.0 - 32.0	13	55	50	55.5
CGS-M50	M50x1.5	24.0 - 38.5	12	65	60	68
CGS-M63	M63x1.5	35.0 - 44.0	12	67	70	79

*NOTE: OD = outside diameter **NOTE: dimensions are in mm

Description

Straight compression type cable glands IP68 5 bar incorporating fixed male threads to provide secure cable connections through knockouts and threaded entries.

Accessories

For extending the capability of Harnessflex cable glands, see page 60 for locknuts, face sealing washers and blanking plugs for unused entries.

Configurations/nominal dimensions/part numbers (PG versions)

Part No.	PG Thread	Cable OD Range		A/F size		
	A	B	C	D	E	F
CGS-PG07	PG7	2.0 - 6.5	8	31	17	19
CGS-PG09	PG9	4.0 - 10.0	8	33.5	21	23.5
CGS-PG11	PG11	6.0 - 12.0	8	35	24	27
CGS-PG13	PG13.5	6.0 - 12.0	9	36	24	27
CGS-PG16	PG16	10.0 - 14.0	10	38.5	27	30
CGS-PG21	PG21	13.0 - 18.0	11	40	30	33
CGS-PG29	PG29	17.0 - 25.0	11	48	41	45.5
CGS-PG36	PG36	24.0 - 32.0	13	55	50	55.5

*NOTE: OD = outside diameter **NOTE: dimensions are in mm

Accessories



Locknut dimensions

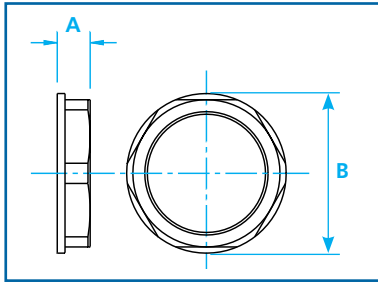

Part No.	Thread size	A	B (A/F)	Part No.	Thread size	A	B (A/F)
LNP-M16	M16x1.5	7	19	LNP-PG07	PG07	5	19
LNP-M20	M20x1.5	8	23	LNP-PG09	PG09	5	22
LNP-M25	M25x1.5	9	28	LNP-PG11	PG11	5	24
LNP-M32	M32x1.5	9	36	LNP-PG13	PG13.5	6	27
LNP-M40	M40x1.5	10	46	LNP-PG16	PG16	6	30
LNP-M50	M50x1.5	10	60	LNP-PG21	PG21	7	36
				LNP-PG29	PG29	7	46
				LNP-PG36	PG36	9	56
				LNP-PG48	PG48	9	59

Face sealing washer dimensions

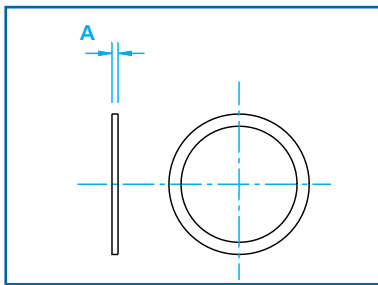

Part No.	Thread	A	Part No.	Thread size	A
SWM16	M16	1.5	SWPG07	PG07	1.2
SWM20	M20	1.5	SWPG09	PG09	1.2
SWM25	M25	1.5	SWPG11	PG11	1.2
SWM32	M32	1.5	SWPG13	PG13.5	1.2
SWM40	M40	1.5	SWPG16	PG16	1.2
SWM50	M50	1.5	SWPG21	PG21	1.2
			SWPG29	PG29	1.2
			SWPG36	PG36	1.2
			SWPG48	PG48	1.2

End sleeve configurations and dimensions

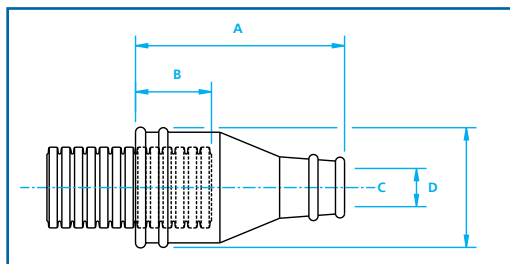

Part Number	Conduit Size		Outlet Dia Range	Nominal Dimensions		
	NC	NW		A	B	C
ESN12	12	10	4 - 8	28	17	19
ESN16	16	13	5 - 9	35	17	23
ESN20	20	17	7 - 14	42	20	28
ESN25	25	22	9 - 17	50	21	31
ESN28	28	23	14 - 22	50	21	34
ESN32	32	29	16 - 32	53	27	40
ESN40	40	36	16 - 30	56	35	50

End caps configurations and dimensions

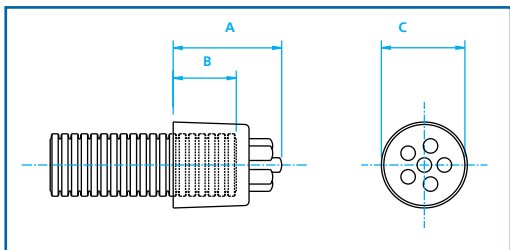

Part Number	Conduit Size		Outlet Dia Range	Nominal Dimensions		
	NC	NW		A	B	C
EK03-08	08	7.5	3	19	13	14
EK03-08	10	8.5	3	19	13	14
EK05	12	10	5	22	14	17

- Integral cable tie grooves**
With twin location points to assist fixing to conduit or connector
- Internal location lip**
Provides internal protection during cable installation
- Multiple cable carrying capacity**
Provides cable breakout facility in situations where sealing is not required
- Multi-function design**
Can be used as flexible conduit size coupler or electrical connector end cover



Accessories

Replaces SRN seal to provide a rotating joint.

Part Number	Conduit Size	
	NC	NW
SC16HX	16	13
SC20HX	20	17
SC28HX	28	23
SC32HX	32	29
SC40HX	40	36
SC50HX	50	48

Push in one piece fitting leaving a smooth exit from conduit when fittings not used.

Part Number	Conduit Size		Nominal Dimensions		
	NC	NW	A	B	C
CES12	12	10	8	15	16
CES16	16	13	9.5	15	18
CES20	20	17	13.5	18	25
CES28	28	23	20.5	20	32
CES32	32	29	25.7	20	38
CES40	40	36	32.3	25	46
CES50	50	48	43.7	25	58

One piece slit insert providing abrasion protection for cables passing through a hinged junction where conduit is not used.

Part Number	Conduit Size		A
	NC	NW	
SEG12	12	10	8
SEG20	20	17	16
GROM08	8	7.5	8
GROM12	12	10	12

*Smoothbore

Swivel C ring configurations and dimensions

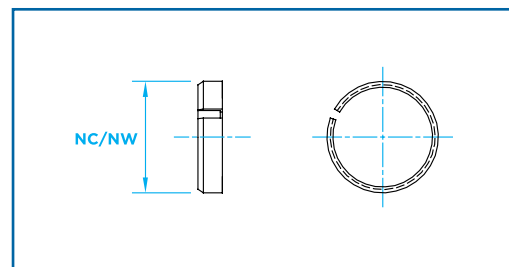

End cap configurations and dimensions

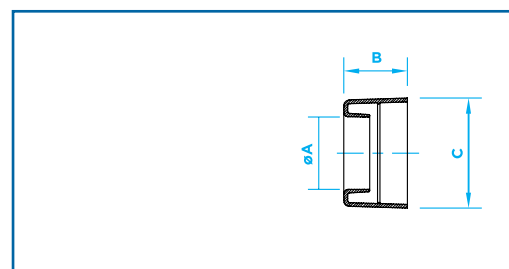

Smooth entry grommet configurations and dimensions

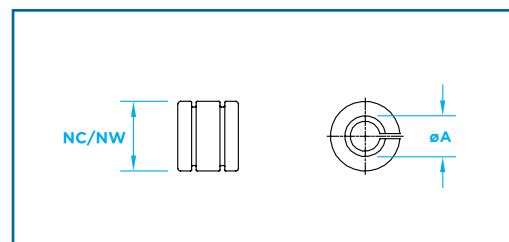

1 Swivel capability

Converts sealed fittings into freely rotating IP40 fittings for dynamic applications

2 High pull-off strength

Split C ring design sits tightly into conduit corrugations



Conduit Clips

Conduit with lid configurations and dimensions

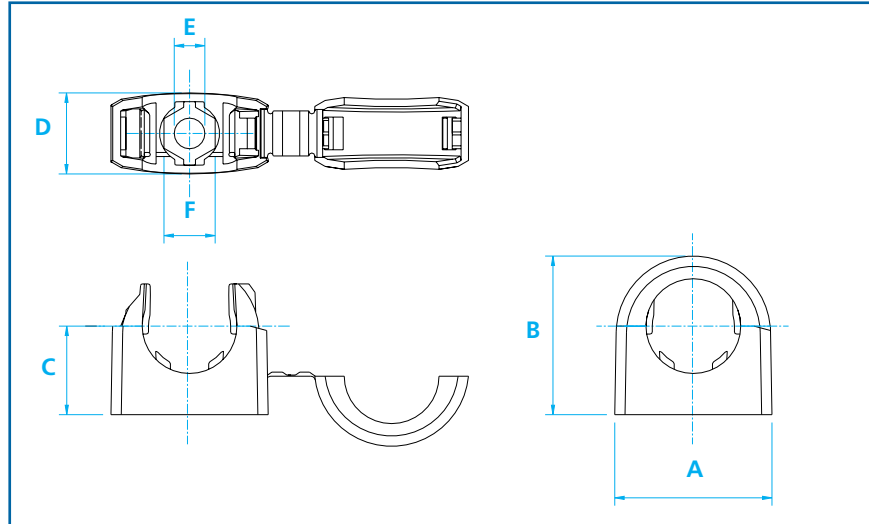

Description

One piece non-metallic conduit clips providing secure mounting points for conduit systems within a Harnessflex system.

These fittings are designed to snap together over all types of slit and unslit conduit thus maintaining maximum conduit bore.

Configuration/nominal dimensions/part numbers

Part No. Clip	Conduit Size		A	B	C	D	Fixing	A/F
	(NC)	(NW)					Hole Size	Counter-Bore Size
HCB08	08	7.5	23	23	13	12	4	8
HCB12	12	10	23	23	13	12	4	8
HCB16	16	13	27	27	15	14	5	9
HCB20	20	17	34	35	20	18	6	10
HCB28	28	23	44	44	23	21	6	10
HCB32	32	29	53	52	27	23	6	10
HCB40	40	36	65	63	32	27	6	10
HCB50	50	48	81	77	39	32	6	10

*NOTE: dimensions are in mm

1 One-piece design overcentre facility

Holds conduit securely in place during harness fabrication

2 Internal conduit location step

Prevents lateral movement of conduit even when lid is open

3 Integral hinged lid

Provides added security when closed and can be removed if not required

4 Integral fixing hole

Provides centre location point with hexagonal counter-bore for use with captive nuts



Conduit Clips

Metallic P-clip configurations and dimensions

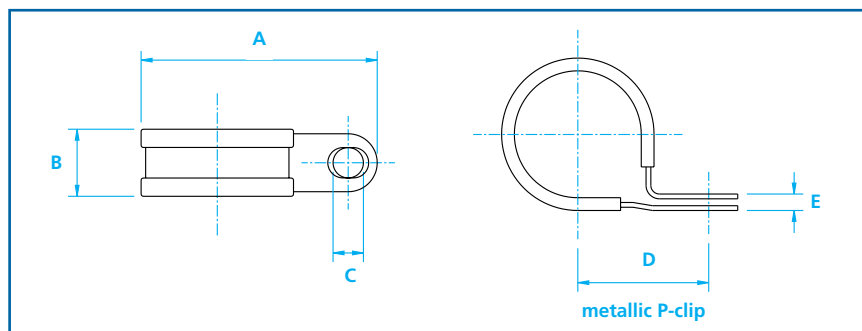

Description

One-piece, metallic P-clips providing secure mounting points for conduit systems within a harness installation.

These clips are designed to accommodate all Harnessflex slit and unslit conduits.

Configuration/nominal dimensions/part numbers

P-Clip	Conduit Size		Fixing Hole Size				
	(NC)	(NW)	A	B	C	D	E
PCS10	10	8.5	31	13	5	16	1.5
PCS12	12	10	33	13	5	17	1.5
PCS16	16	13	36	13	5	19	1.5
PCS20	20	17	41	13	5	21	1.5
PCS25	25	22	45	13	5	23	1.5
PCS32	32	29	53	13	5	27	1.5
PCS40	40	36	76	25	14	38	2.4
PCS50	50	48	86	25	14	43	2.4

*NOTE: dimensions are in mm

Description

One-piece, non metallic conduit clips providing secure mounting points for conduit systems within a harness installation.

Base unit provides a strong and secure location, while rotating conduit clip prevents detachment through vibration. These clips are designed to snap together and securely locate Harnessflex slit and unslit conduits.

Modular conduit clip

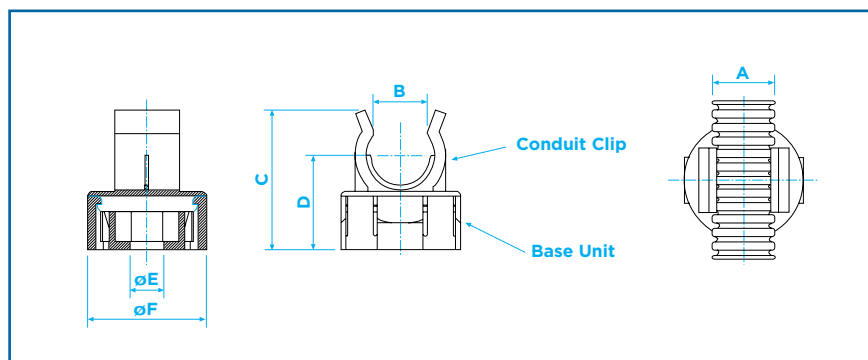

Nominal dimensions

Conduit Clip	Base Unit	A	B	C	D	E	F	Colour
MCS22-08	MCB22 NC08	NW7.5	7	22	16	6.2	22	Black
MCS22-12	MCB22 NC12	NW10	10	25	17.5	6.2	22	Grey

*NOTE: Order base unit and conduit clip separately **NOTE: dimensions are in mm

Storage Recommendation for Polyamide Products

Storage recommendation for polyamide products
Polyamide is widely and successfully used for products in the electrical and electronics industries. Thanks to its excellent mechanical and physical properties over a wide range of application temperatures and its very good weather resistance, polyamide can be used to make products for interior and external use that meet the most stringent of demands.

As a hygroscopic material, polyamide has the ability to absorb moisture in molecular form into the plastic matrix. As the moisture content goes up, product properties may change slightly. Absorbed water acts as a plasticiser reducing strengths and moduli and increasing the toughness of the polyamide.

Although at room temperature the stiffness and strength of PA6 is more reduced by the moisture uptake than those of PA66, this difference can be considered to be non-significant. PA6 absorbs more water than PA66, especially under high humidity conditions. But the resulting dimensional change is still of a similar order.

The following chart shows how the moisture content of polyamides comes into balance with the ambient air in a normal climate of 50% relative humidity and 23°C:

Material	In air (23°C / 50% rh)
Polyamide 6	3.0-3.5% by weight
Polyamide 66	2.5-3.0% by weight

To maintain balanced moisture content, Harnessflex recommends storing products under the following conditions:

Storage temp	Processing temp.	Rel. humidity
18°C to 30°C	>18°C	>30%

At lower processing temperatures and in particular when subjected to unnatural drying, corrugated pipes display increased flexural rigidity.

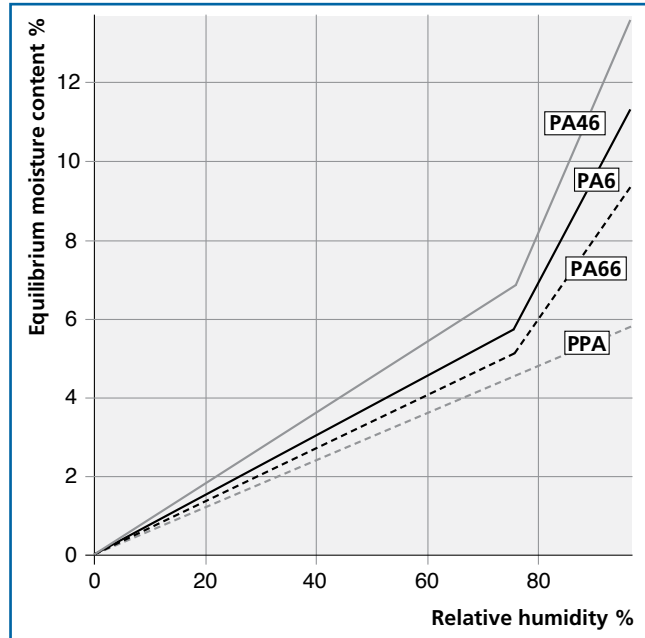

In the very dry winter months the moisture balance may go down slightly as the material releases moisture to the environment (owing to lower relative humidity). Compared to natural outdoor conditions* at around 0°C (40... 80% rh), the humidity in heated rooms may drop by half to below 20% rh if no humidification is present. (Even extremely dry regions such as the Sahara Desert record average humidity of 20% to 60% rh.) (*Central European climate.)

If products from an outside environment are brought into a heated processing area, the change in climate may suddenly cause temporary de-moisturisation around the edges. After one or two days in the processing area a natural balance will be restored.

Observing this storage recommendation ensures optimum processability and material properties

IP Classification

The first digit stands for protection against solid bodies



The second digit stands for protection against water



Index of Ingress Protection

IPxx suitability ratings are a system for classifying the degree of protection provided by enclosures of electrical equipment. The higher the number, the greater the degree of protection, in accordance with standards EN 60529 / DIN 40050-9.

Protection standards

- Protection against solid bodies
- Protection against liquids

Protection against Solid Bodies

	0	No protection
	1	Protected against solid bodies of 50mm and greater, (e.g. accidental contact with the hand)
	2	Protected against solid bodies of 12.5mm and greater, (e.g. accidental touch by fingers)
	3	Protected against solid bodies of 2.5mm and greater, (e.g. tools and wires)
	4	Protected against solid bodies of 1mm or greater, (e.g. thin tools and fine wires)
	5	Protected against dust - limited ingress (no harmful deposits)
	6	Totally protected against dust (Dust-tight)

Protection against Liquids

	0	No protection
	1	Protected against vertically falling drops of water (condensation)
	2	Protected against drops of water falling up to 15° from the vertical
	3	Protected against drops of water falling up to 60° from the vertical
	4	Protected against splashing water from all directions
	5	Protection against jets of water from all directions
	6	Protection against powerful jets of water from all directions
	7	Protected against the effects of temporary immersion in water
	8	Protected against the continuous effects of immersion in water having regard to specific conditions
	9	IP69k Automotive standard DIN40050 signifies resistance to high pressure jets (up to 80bar) from any angle

Nylon (PA) 6

Nylon (PA) 6 - Used on: All Harnessflex NC and CTPA nylon conduits

Properties	Test Method	Value	Unit
General			
Density	ISO 1183	1.13	g/cm ³
Melting Point	ISO 11357-1/-3	220	°C
Mechanical			
Tensile Strength	ISO 527	55 (con)	MPa
Elongation at break	ISO 527	>50 (con)	%
Youngs Modulus	ISO 527	3100 (Dry)	MPa
Charpy impact strength	ISO 179	DNB (Dry)	kJ/m ²
Charpy notched impact strength		11 (Dry)	kJ/m ²
IZOD impact strength	ISO 180C	DNB (Dry)	kJ/m ²
IZOD notched impact strength	ISO 180A	4 (Dry)	kJ/m ²
Thermal			
Heat Distortion Temperature-A	ISO 75	100	°C
Heat Distortion Temperature-B	ISO 75	>200	°C
Flammability			
Flammability	UL94	HB	N/A
Electrical			
Dielectric strength	IEC 243	14 (Dry)	MV/m
Surface Resistivity	IEC 93	15 (Dry)	log10Ω
Volume Resistivity	IEC 93	15 (Dry)	log10Ω
Comparative Tracking Index	IEC 112	>600	V

Notes

DNB = Did not break, Dry = Dry as moulded, Con = Conditioned 168hrs @ 23°C, 50 % RH.
All tests undertaken at 23°C where applicable.

Chemical resistance

Nylon 6 Harnessflex conduits are resistant to all underbonnet oils, greases, fuels, cleaning fluids and synthetic fluids.
Like all Nylons they are resistant to weak acids but not resistant to strong or oxidizing acids.

Peek (PolyEtheretherKetone)

PEEK (PolyEtheretherKetone) - Used on: PKC conduit

Properties	Test Method	Value	Unit
General			
Density	ISO 1183	1.32	g/cm ³
Melting Point	DEC	343	°C
Mechanical			
Tensile Strength	ISO 527	97	MPa
Elongation at break	ISO 527	<60	%
Youngs Modulus	ISO 527	3600	MPa
Charpy impact strength 2mm notch	ISO 179	35	kJ/m ²
Charpy impact 0.25mm notch	ISO 179	8.2	kJ/m ²
IZOD impact strength	ISO 180	DNB	kJ/m ²
IZOD impact strength 0.25mm notch	ISO 180	6.4	kJ/m ²
Thermal			
Heat Distortion Temperature-A	ISO 75	152	°C
Heat Distortion Temperature-B	ISO 75		°C
Flammability			
Flammability	UL94	V0	N/A

Electrical

Dielectric strength	IEC 243	190	kV/m-1
Surface Resistivity	IEC 93		
Volume Resistivity	IEC 93	4.9	10 ¹⁶ Ω cm
Comparative Tracking Index I	EC 112	150	V

Notes

DNB = Did not break. All tests undertaken at 23°C where applicable. This linear aromatic polymer is semi-crystalline and is widely regarded as the highest performance thermoplastic material currently available. A summary of key physical properties is as follows:

High Temperature Performance

PEEK polymer and compounds typically have a glass transition temperature of 143°C and a melting temperature of 343°C and a Continuous Use Temperature of 260°C (UL 746B).

Wear Resistance

PEEK polymer has excellent friction and wear properties exhibiting outstanding wear resistance over wide ranges of pressure, velocity, temperature and counterfacial roughness.

Chemical Resistance

PEEK polymer has excellent resistance to a wide range of chemical environments, even at elevated temperatures. The only common environment which dissolves PEEK polymer is concentrated sulphuric acid.

Fire, Smoke and Toxicity

PEEK polymer is highly stable and requires no flame-retardant additives to achieve a V-0 rating at 1.4mm thickness. The composition and inherent purity of the material results in extremely low smoke and toxic gas emission in fire situations.

Hydrolysis Resistance

PEEK polymer and compounds are not chemically attacked by water or pressurized steam. Components which are constructed from these materials retain a high level of mechanical properties when continuously conditioned in water at elevated temperatures and pressures.

Electrical Properties

The electrical properties of PEEK™ polymer are maintained over a wide frequency and temperature.

Nylon (PA) 66 - Heat Stabilised

Nylon (PA) 66 - Heat stabilised - Used on: All Harnessflex un-reinforced nylon fittings

Properties	Test Method	Value	Unit
General			
Density	ISO 1183	1.14	g/cm ³
Melting Point	ISO 1218	263	°C
Mechanical			
Tensile Strength	ISO 527	95 (Dry)	MPa
Elongation at break	ISO 527	23 (Dry)	%
Youngs Modulus	ISO 527	3400 (Dry)	MPa
Flexural Modulus	ISO 178	2850 (Dry)	MPa
Charpy impact strength	ISO 179	DNB (Dry)	kJ/m ²
Charpy notched impact strength		6 (Dry)	kJ/m ²
IZOD impact strength	ISO 180C	DNB (Dry)	kJ/m ²
IZOD notched impact strength	ISO 180A	5 (Dry)	kJ/m ²
Thermal			
Heat Distortion Temperature @1.8Mpa	ISO 75-2	85	°C
Heat Distortion Temperature @ 0.45MPa	ISO 75-2	230	°C
Flammability			
Flammability	UL94	V2	N/A
Glow wire flammability @ 1.5mm	IEC 695-2-1/2	850 (Con)	°C
Electrical			
Dielectric strength	IEC 243	60 (Dry)	MV/m
Surface Resistivity	IEC 60093	1E+15	Ω
Volume Resistivity	IEC 60093	1E+15	Ω.cm
Comparative Tracking Index	IEC 60112	600	V

Nylon (PA) 66 - 30% Glass Fibre Filled

Nylon (PA) 66 - 30% Glass Fibre Filled - Used on SC-M27 and SC-M24 swivel nuts

Properties	Test Method	Value	Unit
General			
Density	ISO 1183	1.36	g/cm ³
Moisture Absorption (1)	Sim to ISO 62	1.6	%
Mechanical (2)			
Tensile stress at yield/break (3)	ISO 527	195	N/mm ²
Elongation at break ISO 527 3 %			
Modulus of elasticity (4)	ISO 527	10000	N/mm ²
IZOD notched impact strength	ISO 180/1A	13	kJ/m ²
	@ +23°C		
	@ -30°C 10 kJ/m ²		
Thermal			
Heat deflection temperature (HDT) ISO 75/A 250 °C			
Ball pressure test IEC 60695-10-2 >200 °C			
Flammability			
Flammability (1.6mm thickness)	UL94	HB	
Oxygen index	ISO4589	24	%
Glow wire test extinguishing time (5)	IEC60695-2-1/1	<15	s
Hot wire ignition (HWI) (1.5mm thickness)	IEC60695-2-20	>15	s
High current arc ignition (HAI) (0.7mm thickness)	IEC60947	>120	No of arcs
Electrical (2)			
Dielectric strength	IEC 60243-1	>30	kV/mm
Specific surface resistivity	IEC 60093	10 ¹⁵	Ω
Specific volume resistivity	EC 60093	10 ¹⁵	Ω.cm
Dielectric constant	IEC60250	3.8	
	@ 100Hz		
	@ 1MHz 3.5		
Dissipation factor			
	@ 100Hz	90	x10 ⁻⁴
	@ 1MHz	160	x10 ⁻⁴
Comparative Tracking Index	IEC 60112	600	V
Electrolytic corrosion	IEC 60426	A1.2	-

Key

1. Moisture absorption, saturation at +23°C and 50% RH (ref. DIN53495).
2. Dry as moulded.
3. Test speed 5mm/min.
4. Test speed 1mm/min.
5. Glow wire applied during 30secs, temperature 750°C, thickness 1.6mm.

Notes

DNB = Did not break, Dry = Dry as moulded, Con = Conditioned 168hrs @ 23°C, 50 % RH.
All tests undertaken at 23°C where applicable.

Chemical resistance

Polyamide (Nylon) 66 Harnessflex fittings are resistant to all underbonnet oils, greases, fuels, cleaning and synthetic fluids. Like all Nylons they are resistant to weak acids but not resistant to strong or oxidizing acids.

Thermoplastic Elastomer TPV

Thermoplastic Elastomer TPV - Used on: sealing products

A polypropylene based elastomer designed primarily for demanding automotive applications. This material exhibits excellent compression set, flex fatigue and high and low temperature performance.



SRN



SWM



SEG



ESN



EK

Properties

General

Density
Hardness shore A (5 sec)
Brittleness temperature
Flammability
Stress/strain properties

Flow Direction

Tensile strength
Modulus 100%
Elongation at break
cross direction
Tensile strength
Modulus 100%
Elongation at break

Tear Strength (cross direction)

Trouser
Un-nicked angle
Compression set
72h/23°C
72h/70°C
72h/100°C

Hot Air Ageing

1000h/125°C
Change in hardness
Retention tensile strength
Retention - elongation at break
336h/150°C
Change in hardness
Retention tensile strength
Retention elongation at break

Volume swell

72h/100°C water
168h/100°C ASTM oil 1
168h/100°C ref fuel B

Test Method

ISO 1183
ISO 868
ISO 812
UL94
ISO 37 (II)

ISO 34 A
ISO 34 B (a)
ISO 815

ISO 188

ISO 1817

Value

0.96
56
-62
HB

3.8
2.7
280

5.1
1.9
470

7
22
22
26
34

2
90
96
0
90
87

+3
+43
+91

Unit

g/cm³
-
°C
-

MPa
MPa
%
MPa
MPa
%

kN/m
kN/m
%
%
%

pts
%
%
pts
%
%

%
%
%

Notes

Tests are conducted on injection moulded plaques. All tests undertaken at 23°C where applicable.

Chemical resistance

TPV fittings are resistant to:

Water, acids, ethanol, glycerol, methanol and propanol, hydraulic brake fluid and antifreeze.

Large volume swell (>60%) is experienced with certain oils and fuels.

Approvals

Individual parts are approved to different standards including NFR 13-903. Others are manufacturer specific or are new developments and may not be approved to certain standards. Please contact the technical office for specific enquiries.

Part No.	Page	Part No.	Page	Part No.	Page	Part No.	Page	Part No.	Page	Part No.	Page	Part No.	Page
TPS161612	19	TPS251225	19	TPS300830	19	TPS323225	19	YPS121210	21	YPS252012	21	YPS282828	21
TPS161616	19	TPS251620	19	TPS301230	19	TPS323232	19	YPS121212	21	YPS252016	21	YPS322032	21
TPS162012	19	TPS251625	19	TPS301625	19	TPS401232	19	YPS160812	21	YPS252020	21	YPS322516	21
TPS162016	19	TPS252020	19	TPS301630	19	TPS401240	19	YPS161010	21	YPS252508	21	YPS322520	21
TPS200816	19	TPS252025	19	TPS302016	19	TPS401632	19	YPS161208	21	YPS252510	21	YPS322525	21
TPS200820	19	TPS252520	19	TPS302020	19	TPS401640	19	YPS161210	21	YPS252512	21	YPS322532	21
TPS201016	19	TPS252525	19	TPS302025	19	TPS402040	19	YPS161212	21	YPS252516	21	YPS323216	21
TPS201020	19	TPS280820	19	TPS302030	19	TPS402540	19	YPS161608	21	YPS252520	21	YPS323220	21
TPS201216	19	TPS280828	19	TPS302525	19	TPS402840	19	YPS161610	21	YPS252525	21	YPS323225	21
TPS201220	19	TPS281020	19	TPS303025	19	TPS404032	19	YPS161612	21	YPS282012	21	YPS323232	21
TPS201612	19	TPS281028	19	TPS303030	19	TPS404040	19	YPS161608	21	YPS282016	21	YPS323220	21
TPS201616	19	TPS281220	19	TPS321632	19	XP20	54	YPS201208	21	YPS282020	21	YPS403212	21
TPS201620	19	TPS281225	19	TPS282528	19	XPS1208	23	YPS201210	21	YPS282512	21	YPS403225	21
TPS202012	19	TPS281228	19	TPS282828	19	YPS080808	21	YPS201212	21	YPS282516	21	YPS403228	21
TPS202016	19	TPS281620	19	TPS321625	19	YPS080812	21	YPS201608	21	YPS282520	21	YPS404012	21
TPS202020	19	TPS281625	19	TPS321632	19	YPS081208	21	YPS201612	21	YPS282525	21	YPS404016	21
TPS202516	19	TPS281628	19	TPS322025	19	YPS101010	21	YPS201616	21	YPS282808	21	YPS404025	21
TPS250820	19	TPS282020	19	TPS322028	19	YPS120808	21	YPS202008	21	YPS282812	21	YPS404028	21
TPS250825	19	TPS282025	19	TPS322032	19	YPS120810	21	YPS202010	21	YPS282816	21	YPS404032	21
TPS251025	19	TPS282028	19	TPS322525	19	YPS121010	21	YPS202012	21	YPS282820	21	YPS404040	21
TPS251220	19	TPS282525	19	TPS322532	19	YPS121208	21	YPS202016	21	YPS282825	21		

Part No.	Ref No.	Notes	Part No.	Ref No.	Notes	Part No.	Ref No.	Notes	Part No.	Ref No.	Notes
CI08-180-K2C			CI08-AS1	282079-2	●	CI12-90-AS1	282079-2	●	CI12-BC4	1 928 403 112	●
CI08-72585			CI08-AS2	282080-1	●	CI12-90-AS2	282080-1	●	CI12-DT2	DT06-2S	●
CI08-90-AM2	347887-3	●	CI08-AS3	282087-1	●	CI12-90-AS3	282087-1	●	CI12-DT3	DT06-3S	●
CI08-90-AM3	1-827578-1	●	CI08-AS4	282088-1	●	CI12-90-AS4	282088-1	●	CI12-DT4	DT06-4S	●
CI08-90-AM4	281804-1	●	CI08-AT2PL	776427-1	●	CI12-90-AT2LP	776427-1	●	CI12-DT6	DT06-6S	●
CI08-90-AS1	282079-2	●	CI08-AT3PL	776427-1	●	CI12-90-AT2LR		●	CI12-DT8	DT06-8SA	●
CI08-90-AS2	282080-1	●	CI08-AT4PL	776487-1	●	CI12-90-AT2PL	776427-1	●	CI12-FCI02		
CI08-90-AS3	282087-1	●	CI08-AT6PL	776433-1	●	CI12-90-AT3LP	776427-1	●	CI12-FCI03		
CI08-90-AS4	282088-1	●	CI08-BC2	1 928 403 137	●	CI12-90-AT3LR		●	CI12-FCI04		
CI08-90-AT2LP	776427-1	●	CI08-BC3	1 928 403 110	●	CI12-90-AT3PL	776427-1	●	CI12-FCI14		
CI08-90-AT2LR			CI08-BC4	1 928 403 112	●	CI12-90-AT4LP	776487-1	●	CI12-MF2		
CI08-90-AT2PL	776427-1	●	CI08-DE001	12078090		CI12-90-AT4LR		●	CI12-WP2		
CI08-90-AT3LP	776427-1	●	CI08-DT2	DT06-2S	●	CI12-90-AT4PL	776487-1	●	CI12-X01		
CI08-90-AT3LR			CI08-DT3	DT06-3S	●	CI12-90-AT6LP	776433-1	●	CI16-90-AT8PL	776494-1	●
CI08-90-AT3PL	776427-1	●	CI08-DT6	DT06-6S	●	CI12-90-AT6LR		●	CI16-90-DT12	DT06-12SA	●
CI08-90-AT4LP	776487-1	●	CI08-F2W			CI12-90-BC2	1 928 403 137	●	CI16-90-DT8	DT06-8SA	●
CI08-90-AT4LR			CI08-FCI02			CI12-90-BC3	1 928 403 110	●	CI16-90-FCI14		
CI08-90-AT4PL	776487-1	●	CI08-FCI03			CI12-90-BC4	1 928 403 112	●	CI16-AT12PL	776494-1	●
CI08-90-AT6LP	776433-1	●	CI08-FCI04			CI12-90-DT12	DT06-12SA	●	CI16-AT8PL	776494-1	●
CI08-90-AT6LR			CI08-GT153			CI12-90-DT2	DT06-2S	●	CI16-DT12 DT06-12SA		●
CI08-90-BC2	1 928 403 137	●	CI08-GT153-Z			CI12-90-DT3	DT06-3S	●	CI16-DT8 DT06-8SA		●
CI08-90-BC3	1 928 403 110	●	CI08-MF2			CI12-90-DT4	DT06-4S	●	CI16-FCI14		
CI08-90-BC4	1 928 403 112	●	CI08-MMP2			CI12-90-DT6	DT06-6S	●	CI16-LK20		
CI08-90-DE001			CI08-MP2			CI12-90-DT8	DT06-8SA	●	CI17-FCI10		
CI08-90-DT2	DT06-2S	●	CI08-MP3			CI12-90-DTP04			CI201220-DRC50		
CI08-90-DT2C			CI08-NV001			CI12-90-FCI02			CI202825-DRC50		
CI08-90-DT3	DT06-3S	●	CI08-PTD2			CI12-90-FCI03			CI20-A31		
CI08-90-DT4	DT06-4S	●	CI08-SU4			CI12-90-FCI04			CI20-AT12PL 776494-1		●
CI08-90-DT6	DT06-6S	●	CI08-TY002	184002-1	●	CI12-90-FCI14			CI251225-DRC50		
CI08-90-FCI02			CI08-WP2			CI12-90-GT153			CI252825-DRC50		
CI08-90-FCI03			CI08-WS2			CI12-90-K2C			CI25-A31		
CI08-90-FCI04			CI10-90			CI12-90-K3C			CI25-FCI50		
CI08-90-FCI14			CI10-90-AM2	347887-3	●	CI12-90-MMP2			CI28-90-25		
CI08-90-FCS02			CI10-90-AM3	1-827578-1	●	CI12-90-MP2			CI28-BC40		
CI08-90-GT153			CI10-90-AM4	281804-1	●	CI12-90-MP3			CI28-CCU138		
CI08-90-K2C			CI10-90-AS2	282080-1	●	CI12-90-WP2			CI32-A31		
CI08-90-K3C			CI10-90-AS3	282087-1	●	CI12-90-X01			CI-DT2C		
CI08-90-MMP2			CI10-90-AS4	282088-1	●	CI12-AM2	347887-3	●	CI-FCS02		
CI08-90-MP2			CI10-AM2	347887-3	●	CI12-AM3	1-827578-1	●	CI-K2C		
CI08-90-MP3			CI10-AM3	1-827578-1	●	CI12-AM4	281804-1	●	CI-K3C		
CI08-90-NV001			CI10-AM4	281804-1	●	CI12-AS1	282079-2	●	CI-MF-90		
CI08-90-PTD2			CI10-AS2	282080-1	●	CI12-AS2	282080-1	●	CIS-90		
CI08-90-S			CI10-AS3	282087-1	●	CI12-AS3	282087-1	●			
CI08-90-SU4			CI10-AS4	282088-1	●	CI12-AS4	282088-1	●			
CI08-90-WP2			CI10-MF2			CI12-AT12PL	776494-1	●			
CI08-AM2	347887-3	●	CI121212-DRC50			CI12-AT4PL	776487-1	●			
CI08-AM3	1-827578-1	●	CI122812-DRC50			CI12-AT6PL	776433-1	●			
CI08-AM4	281804-1	●	CI12-90-AM2	347887-3	●	CI12-AT8PL	776494-1	●			
			CI12-90-AM3	1-827578-1	●	CI12-BC2	1 928 403 137	●			
			CI12-90-AM4	281804-1	●	CI12-BC3	1 928 403 110	●			

● All Colour and Wire ● All Bosch Kompact ● All Colour ● All Colour and Key

Harnessflex was established in 1984 and is a leading designer and manufacturer of flexible conduit systems and connector interfaces, protecting critical electrical and electronic wiring assemblies in the automotive industry. Our cable protection systems are principally focussed on chassis and engine manufacturers within bus, truck, agricultural vehicle and heavy machinery markets.

Harnessflex
UK Head Office

英国Harnessflex Conduit Systems电缆护套管及
配件产品授权中国代理商

信德迈科技(北京)有限公司 CNMEC Technology Company

地址：北京市朝阳区望京SOHO-T1-C座2115室

邮编：100102

*Tel: 010-8428 2935 | * Fax: 010-8428 8762

*手机：139 1096 2635

*电子邮件：sales@cnmec.biz

主页：<http://www.cnmec.biz/tnb/harnessflex.htm>

The content of the Thomas & Betts catalogue has been carefully checked for accuracy at the time of print. However, Thomas & Betts doesn't give any warranty of any kind, express or implied, in this respect and shall not be liable for any loss or damage that may result from any use or as a consequence of any inaccuracies in or any omissions from the information which it may contain.

Copyright Thomas & Betts 2011. Copyright in these pages is owned by Thomas & Betts except where otherwise indicated. No part of this publication may be reproduced, copied or transmitted in any form or by any means, without our prior written permission. Images, trade marks, brands, designs and technology are also protected by other intellectual property rights and may not be reproduced or appropriated in any manner without written permission of their respective owners. Thomas & Betts reserves the right to change and improve any product specifications or other mentions in the catalogue at its own discretion and at any time. These conditions of use are governed by the laws of the Netherlands and the courts of Amsterdam shall have exclusive jurisdiction in any dispute.