

AMPSEAL AUTOMOTIVE INTERFACES

Description

A new range of straight fittings offering a compact and high integrity connection between the Ampseal automotive connectors and **Harnessflex conduit systems**.

These interfaces provide complete cable protection right up to the connector. They also provide strain relief and protection from high pressure washing, helping to maintain the sealing integrity of the connector.

These fittings are designed to snap together over all **Harnessflex slit and unslit conduits** including **NC, CTPA, MPP and DSPP**.

Compact 90°elbow interface version also available.

Specifications

Material: Nylon (Polyamide 6,6)
 Colour: Black
 IP rating: IP40
 Pull off: Nominally 120N

Operating temperature range

Static Applications -40 to 120°C

Dynamic:

Continuous: -5 to 120°C

Short term: -5 to 150°C

Complies with the end of life vehicle directive ELV/EU 2000/53/EC

other external hinged fittings & accessories.

Including 'Y' pieces, 'T' pieces, elbows, joiners, connector interfaces, customised manifolds, multi-way reducers and smooth end grommets

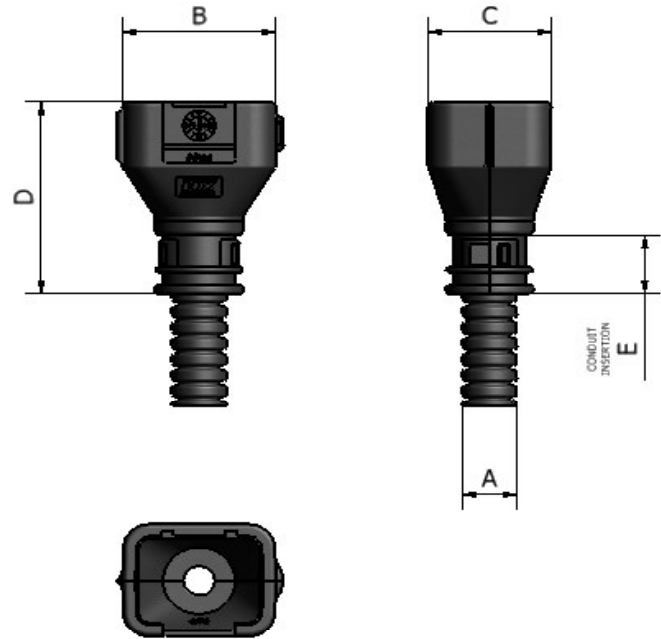

PART NUMBER	CONNECTOR	Conduit size A	Nominal Dimensions (mm)			
			B	C	D	E
CI08-AT2PL	2 Way	NC08	23	17	34	12
CI08-AT3PL	3 Way	NC08	28	17	34	12
CI08-AT4PL	4 Way	NC08	28	23	38	12
CI08-AT6PL	6 Way	NC08	28	23	38	12
CI12-AT4PL	4 Way	NC12	28	23	37	11
CI12-AT6PL	6 Way	NC12	28	23	37	11
CI12-AT8PL	8 Way	NC12	32	23	37	11
CI12-AT12PL	12 Way	NC12	41	23	37	11
CI16-AT8PL	8 Way	NC16	32	23	37	11
CI16-AT12PL	12 Way	NC16	41	23	37	11
CI20-AT20PL	20 Way	NC20	41	25	48	12



Contact details:

Harnessflex Limited.

PO Box 7690,

Birmingham.

B46 1HS, UK

tel: +44 (0)1675 468222

fax: +44 (0)1675 464930

e-mail: sales@harnessflex.co.uk