









Selector Chart For Fuseholders

Panel Mount					
Series / page	FPG / 74	FPG / 76	FPG / 77	FBS / 86	FEU / 80
Panel mount	•	•	• rear mount	•	•
Solder/quick terminals	•	•	•	•	•
Solder terminals					•
Holds 5x20mm fuse	•	•	•	•	
Holds 5x20mm or 1/4 x 1 1/4" fuse					•

Finger grip or slotted fuse carriers available for most styles – ordered separately. Watertight and medical grade versions available.

Panel and Pcb Mount					
Series / page	FIZ, FUL / 82	FPG / 84	FPG, FBS / 83	FAC / 85	FAU / 85
Panel mount	•				
Pcb mount		•	•	•	•
Quick terminals	•				
Holds 5x20mm fuse	•	•	•		
Holds 5x20mm or 1/4 x 1 1/4" fuse	•			•	•

Finger grip or slotted fuse carriers available for most styles – ordered separately. Watertight and medical grade versions available.

Pcb Mount Blocks and Clips					
Series / page	OMH / 87	OG, OGN, OGD / 88	UH, UHB, RSH / 89	OG / 91-92	FMS, FMR / 90
Surface mount	•	•			
Through-hole mount		•	•	•	•
Screw mount			•		
Holds SMT fuse	•				
Holds 5x20mm fuse		•	•	•	
Holds 5x20mm or 1/4 x 1 1/4" fuse		•	•	•	for series MSF 125V microfuse

About Shock Safety for Fuseholders and Power Entry Modules

Miniature Fuses

Miniature Fuses are protective devices for electrically powered apparatus, small motors, measuring instruments, semiconductors, or assembled circuits. They protect against damage and destruction as a result of unacceptable current loads and short circuits. According to VDE 0820 and IEC 257, miniature fuses consist of a fuseholder, a fuse, and possibly a bayonet-type cap (fuse carrier). A distinction is made between open and closed types. The particular advantage of the closed designs is that there is less risk of electrical shock both in normal use and while changing the fuse.

Extra-safe handling with Schurter power entry modules

Protection against contact with live parts is an important aspect when dealing with electrical connecting devices. Both your customers and your servicing engineers will appreciate the greatest possible protection against accidental contact with live parts—something which can easily happen as a result of inappropriate use, or during servicing or repair work. In particular, our "shock-safe," "extra-safe fuse-drawers" and "protective covers" precautions are effective ways of protecting against accidental contact when using the power entry modules.

Explanations, thermal requirements, selection criteria

1. Protection against electric shock (against direct contact with live parts) for fuseholders

The assessment of the protection against electric shock assumes that the fuseholder is properly assembled, installed and operated as in normal use, e.g., on the front panel of the equipment.

IEC 60127-6 and EN 60127-6 divides into three categories:

Category	Features
PC1	Fuseholders without integral protection against electric shock. They are only suitable for applications where corresponding additional means are provided to protect against electric shock.
PC2	Fuseholders with integral protection against electric shock Live part is not accessible: - when the fuseholder is closed - after the fuse carrier (incl. fuse) has been removed - either during insertion or removal of the fuse carrier (inc. fuse) Compliance is checked by using the standard test finger specified in IEC 60529.
PC3	Fuseholder with enhanced integral protection against electric shock The requirements for this category are the same as those for category PC2, with the exception that the testing is carried out with a rigid test wire of 1 mm diameter according to IEC 60529, table VI, instead of the standard test finger.

Remarks on PC2

a) Closed fuseholder

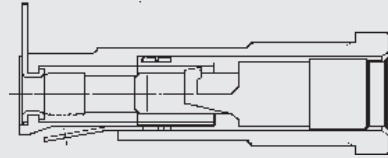

b) When the fuse carrier is removed, no live parts can be touched.

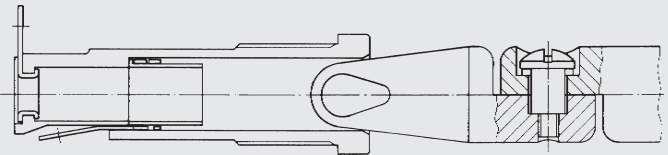

c) During insertion or removal of a fuse, no live parts can be touched, neither through the fuse nor the fuse carrier.

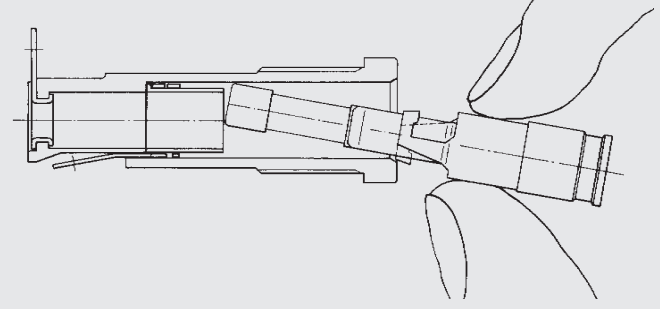

Remarks on PC3

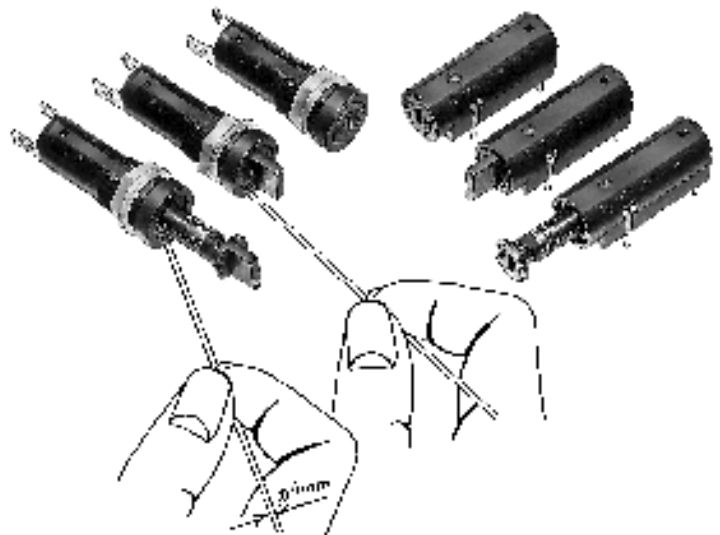

About Shock Safety For Power Entry Modules, continued

2. Thermal requirements of the fuseholder

2.1 Influencing factors

The design engineer of electrical equipment is responsible for its safety and functioning to humans, animals and real values. Above all, it is his task to make sure that the state of the art as well as the valid national and international standards and regulations be observed.

In view of the safety of electrical equipment the selection of the most suitable fuseholder is of great importance. Among other parameters, one has to make sure that the maximum admissible power acceptances and temperatures defined by the manufacturer are followed. Differing definitions and requirements in the most important standards for fuses and fuseholders are time and again origin for the incorrect selection of fuseholders.

To equate the rated current of a fuse with the rated current of the fuseholder, may, especially at higher currents, cause high, not admissible temperatures, when the influence of the power dissipation in the contacts of the fuseholder was not taken into consideration.

For a correct selection, the following influence factors, depending on the application and mounting method, have to be followed:

1. Rated power dissipation of the suitable fuse.
2. Admissible power acceptance, operating current and temperatures of the suitable fuseholder.
3. Differing ambient air temperatures outside and inside of the equipment.
4. Length and cross section of the connecting wire.
5. Head dissipation/cooling, ventilation. Heat influence of adjacent components.

2.2 Rated current of a fuseholder

The value of current assigned by the manufacturer of the fuseholder and to which the rated power acceptance is referred.

2.3 Rated power dissipation of the fuse

(power dissipation at rated current)
See product group "fuses," page 102.

2.4 Rated power acceptance and admissible temperatures of a fuseholder.

The rated power acceptance of a fuseholder is determined by a standardised testing procedure according to IEC 60127-6. It is intended to be the power dissipation caused by the inserted dummy fuse at the rated current of the fuseholder and at an ambient air temperature of $T_{A1} = T_{A2} = 23^\circ\text{C}$ (over a long period). During this test the following temperatures must not be exceeded on the surface of the fuseholder:

Fuseholder surface area	Maximum allowable temperature measuring points (see figure 1)	°C
1. Accessible parts ¹⁾	T_{S1}	85
2. Inaccessible parts ¹⁾ Insulating parts	T_{S2}	²⁾

NOTES:

- 1) When the fuseholder is properly assembled, installed and operated as in normal use, e.g., on the front panel of equipment.
- 2) The maximum allowable temperature of the used insulating materials corresponds to the Relative Temperature Index (RTI) according to IEC 60216-1 or UL 746 B.

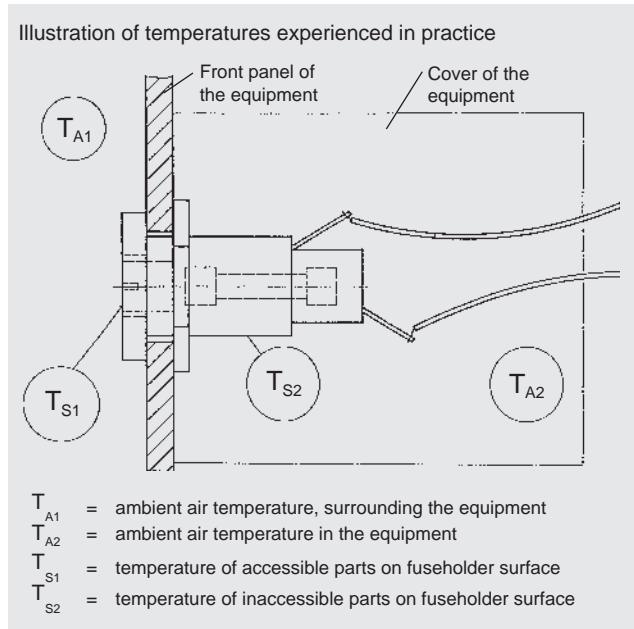

2.5 Correlation between operating current I , ambient air temperature T_{A1} and the power acceptance P_h of the fuseholder.

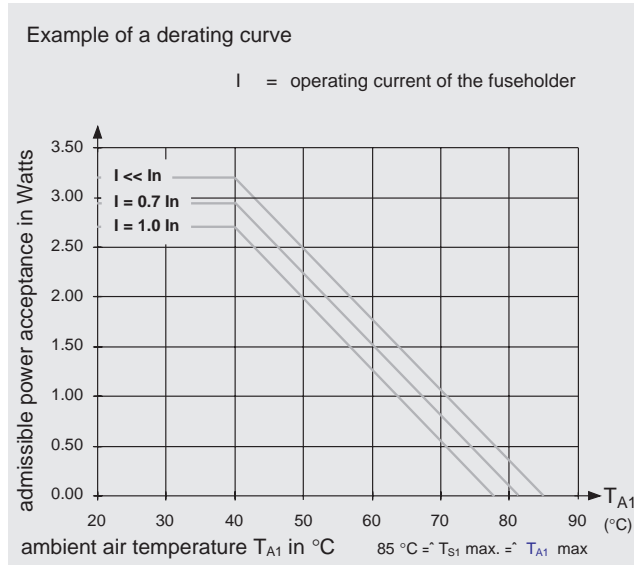

The derating curves demonstrate the admissible power acceptance of a fuseholder depending on the ambient air temperature T_{A1} for the following fuseholder operating currents: $I \ll I_n$, $I = 0,7 \cdot I_n$ and $I = 1,0 \cdot I_n$. This power acceptance corresponds to the max. admissible power dissipation of a fuse-link.

The corresponding values for other operating currents can be interpolated between the existing curves or calculated as follows:

$$P_h = P_o - P_c = P_o - (R_c \cdot I^2)$$

P_h = admissible power acceptance in watt of the fuseholder, depending on T_{A1}

About Shock Safety For Power Entry Modules, continued

- P_o = admissible power acceptance in watt of a fuseholder at $I \ll I_n$, depending on T_{A1} . The values can be taken from the derating curve $I \ll I_n$ of the corresponding fuseholder.
 P_c = power dissipation in watt in the fuseholder contacts at the operating current in ampere.
 I = operating current in ampere of the fuseholder.
 R_c = contact resistance in ohm between the fuseholder terminals according to SCHURTER's catalog.

3. Selection of a suitable fuseholder with respect to the power acceptance at the corresponding ambient air temperature.

Summary

The adherence to the limits, indicated by SCHURTER, in particular the power acceptance limits at the corresponding ambient air temperatures and mounting conditions of the fuseholder, is important for the safety of the product. It is therefore necessary to observe the following two steps:

Step 1

Selection of the fuseholder based on the power acceptance P_h at operating current I and maximum ambient air temperature T_{A1} .

$$P_f \leq P_h = P_o - P_c = P_o - (R_c \cdot I^2)$$

P_f = rated power dissipation in watt of the fuse-link, calculated from $(I_n \cdot \Delta U)$, whereas:

I_n = rated current in ampere of the fuse-link

ΔU = voltage drop in volt at I_n ; values according to SCHURTER's catalog.

P_h, P_o, P_c, R_c = see pos. 2.5

Step 2

The reduction of the power acceptance of the fuseholder (from step 1) based on the different conditions at the mounting place etc. have to be determined by the design engineer responsible.

Examples:

- ambient air temperature is considerably higher inside of an equipment than outside ($T_{A2} > T_{A1}$)
- cross-section of the conductor, unfavourable heat dissipation
- heat influence of adjacent components

Therefore, temperature measurements on the appliance under normal and faulty conditions are absolutely necessary.

4. Example

4.1 What's given?

- Fuse FSF 0034.1523, rated current $I_n = 5$ A.
Voltage drop ΔU at $I_n = 80$ mV, typ.
Rated power dissipation $P_f = (I_n \cdot \Delta U) = (5 \text{ A} \cdot 0,08 \text{ V}) = 0,4 \text{ W}$.
- Fuseholder FEF 0031.1081, rated current $I_n = 10$ A
Rated power acceptance at $T_{A1} 23^\circ\text{C} = 3,2 \text{ W}$.
- Ambient air temperature = 50°C .
Admissible power acceptance P_h at an ambient air temperature $T_{A1} 50^\circ\text{C}$ according to the derating curve:

$$P_h \text{ at } I \ll I_n = 2,5 \text{ W}$$

$$I = 0,7 \cdot I_n = 7 \text{ A} = 2,2 \text{ W}$$

$$I = 1,0 \cdot I_n = 10 \text{ A} = 2 \text{ W}$$
- Contact resistance $R_c = 5 \text{ m}\Omega$

4.2 What is the admissible power acceptance P_h of the fuseholder?

Solutions

4.2.1 The result of the interpolation for the rated current $I = 5$ A is a P_h of approx. 2,4 W.

4.2.2 The result of the calculation is
 $P_h = P_o - (R_c \cdot I^2) = 2,5 - (0,005 \cdot 5^2) = 2,37 \text{ W} \approx 2,4 \text{ W}$.

Derating curves of the fuseholder, type FEF, rated current $I_n = 10$ A

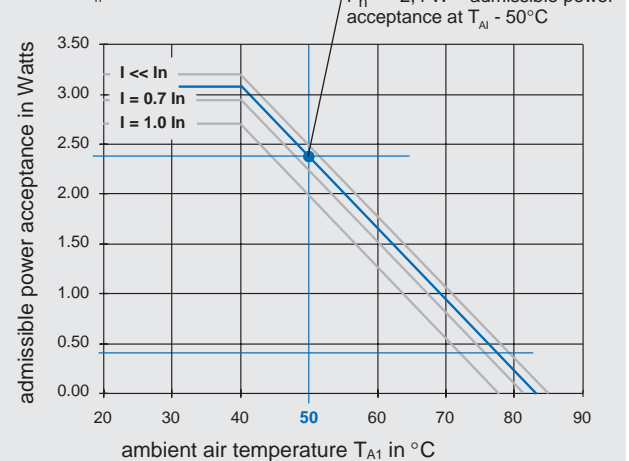

4.4 Verification of the thermal requirements

Step 1

The following condition must be fulfilled:

$P_f \leq P_h$ © this means: the rated power dissipation P_f of the fuse-link must be less/equal than the admissible power acceptance P_h of the fuseholder.

$$P_f = 0,4 \text{ W}; P_h = 2,4 \text{ W at } T_{A1} = 50^\circ\text{C}$$

Step 2

To consider the different conditions at the mounting place according to step 1, see illustration in section 2.4.

4.5 Conclusion (without consideration of step 2)

- The value P_f is less than P_h . The condition according to formula is fulfilled. It has been chosen a suitable fuseholder.
- If the value P_f were greater than P_h the condition wouldn't be fulfilled. In that case, do select another fuseholder with a higher power acceptance or change the thermal conditions at the fuseholder mounting place.

About Shock Safety For Power Entry Modules, continued

5. Standards for fuseholders

IEC	EN	NF	UL	CSA	Title
IEC 257	EN 60257				Fuseholders for miniature fuse-links. This standard has been replaced by the new standard IEC 60127-6.
IEC 60127-6	EN 60127-6				Fuseholders for miniature fuse-links. This standard replaces the IEC 257.
		NF C93-436			Fuseholders for professional purposes
			UL 512		Fuseholders
				CSA, C22.2-39	Fuseholder assemblies

IEC: International Electrotechnical Commission

EN: European Standard

NF: French Standard

UL: Underwriters Laboratories Inc. USA

CSA: Canadian Standards Association

6. Explanation to the main fuseholder standards

As mentioned in section 2, the most relevant standards define rated current and rated power acceptance differently. This led in the past often to confusion or even to a wrong fuseholder design-in.

For example the standard UL 512 does not define a maximum power acceptance value, but sets a certain value of temperature rise for the fuseholder. For this reason the marked amperage values on the fuseholder, defined by UL and CSA, are not suggested to be used except in special cases.

In order to eliminate such confusion, SCHURTER new decided to define the rated current and rated power acceptance values according to IEC 60127-6 and EN 60127-6.

The most important definitions are to be found in section 2.

Conclusion

- The high UL and CSA current ratings are replaced by more realistic rated currents defined by SCHURTER.
- Focused on the new fuseholder standard IEC 60127-6 and EN 60127-6, the power acceptance of several fuseholders had to be reduced.
- The design-in procedure and in particular to choose the correct fuseholder in terms of thermal requirements (refer to section 2-4) is now made much easier.

Your advantages:

- More security for your equipment
- Faster and much easier selection of the correct fuseholder

Extra-Safe Medical Fuse Drawers for Power Entry Modules

For added safety, extra-safe fuse drawers are available for the SCHURTER line of power entry modules (with and without mains filters). The drawer can only be removed with the aid of a tool (e.g. screwdriver) so that opening by hand is virtually impossible. With the KEA series, it is also necessary to pull out the mains outlet first. Only then can the drawer be removed from the socket. Extra-safe fuse drawers are able to satisfy the following standards and international specifications: Appliance standard IEC 601-1, BS 5724 part 1, and DIN/VDE 0750 part 1 (suitable for medical applications).

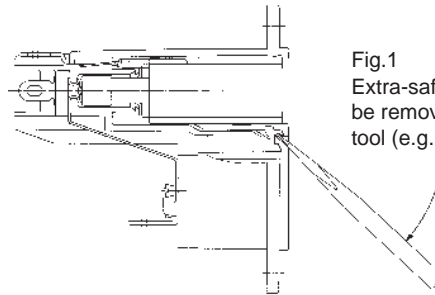

Fig.1
Extra-safe fusedrawer can only be removed with the aid of a tool (e.g. screwdriver)

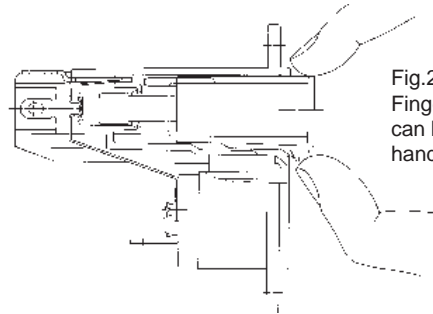

Fig.2
Finger-grip fusedrawer can be removed by hand

About Power Dissipation

Power dissipation is the product of voltage drop multiplied by rated current. Power dissipation generates heat. High in-rush and/or higher operating temperatures can become a problem. Too much heat may lead to melting of the plastic, contact problems, premature failure of the fuse, etc. Therefore, suitable fuseholders/power entry modules must be selected not only by desired function and application specific requirements, but also by the amount of power dissipation through the area holding the fuse.

Current ratings for fuseholders/power entry modules vary widely from agency to agency, due to different methods used for temperature rise testing. For the specifier, it is important to know that the temperature rise testing is performed at UL and CSA using dummy inserts in place of actual fuses. European test agencies, however, rely on IEC methods that reflect more realistic field conditions. Current ratings provided by the test agency should always be observed. However, it is imperative that attention also be given to the maximum permissible power dissipation values provided by the manufacturer when selecting a fuseholder/power entry module.

For further clarification, please refer to the following excerpt from IEC 257 amendment 2, as shown below:

- Depending upon the type of fuse-link applied in the holder and the possible prolonged overloads of this fuse-link, the contributions to the actual power dissipation in the holder produced by the contact resistances and the fuse-link may vary considerably.
- Certain types of miniature fuse-links, covered by IEC Publication 127-2, especially the quick-acting type with high breaking capacity, may sustain overloads at a level of 1.7 to 2.1 times rated current for a considerable period of time. The application of such fuse-links in closed fuseholders can under those circumstances result in temperature rises of the holder and its accessible parts, beyond the limits e.g. given in IEC Publication 65: Safety Requirements For Mains Operated Electronic and Related Apparatus For Household and Similar Use.

Attention should therefore be given to the possibility of a dangerous situation arising out of such overloads.

MAXIMUM POWER DISSIPATION VALUES

Ambient temperature +23°C (±0.1) according to IEC 127-6

Fuseholders

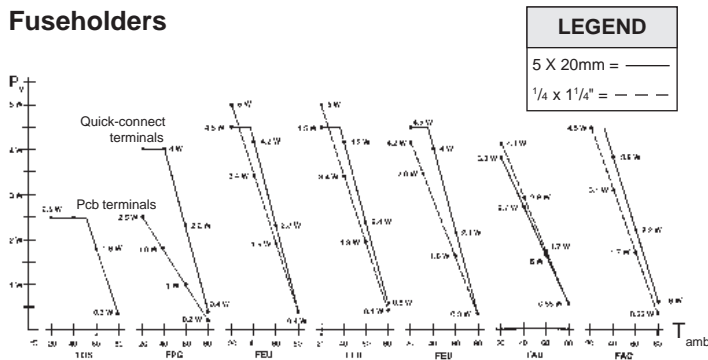

Values are determined at ambient temperatures ranging from +20°C to +80°C

Fuseholders

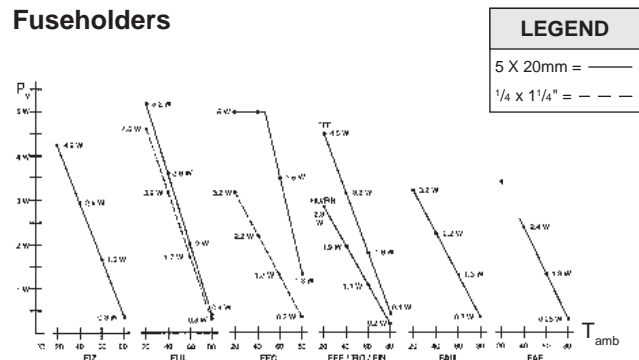

Values are determined at ambient temperatures ranging from +20°C to +80°C

Power Entry Modules

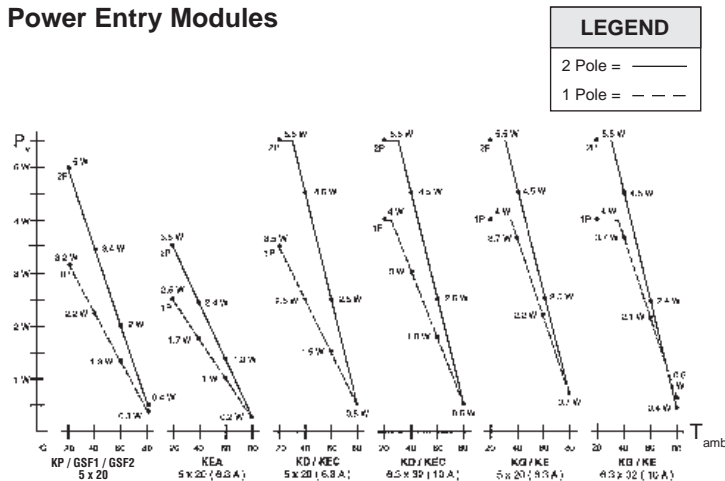

Values are determined at ambient temperatures ranging from +20°C to +80°C

Power Entry Modules

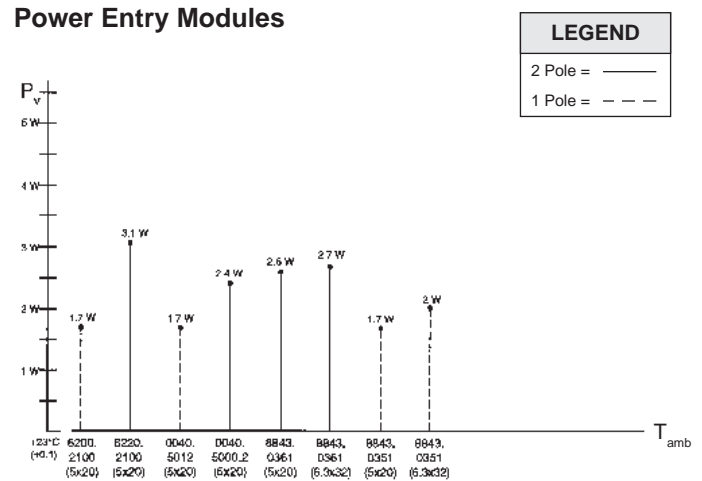

Values are determined at ambient temperature +23°C. Values at a higher ambient temperature on request.

FPG

“Press fit” Panel Mount Fuseholders for 5 x 20mm Fuses



NEW



FPG

- Rated voltage: 250 V
- New panel-mount, front side, press-fit mount, secured with potting compound on the rear side
- Shocksafe category PC2
- Rated voltage: 250 V
- Rated current: 10 A
- Rated power acceptance at ambient air temperature T_a 23 °C: 2.5 W
- Power acceptance at higher T_a : see derating curves
- Allowable ambient air temperatures T_a for accessible parts: -25 to +85 °C

Panel thickness max.

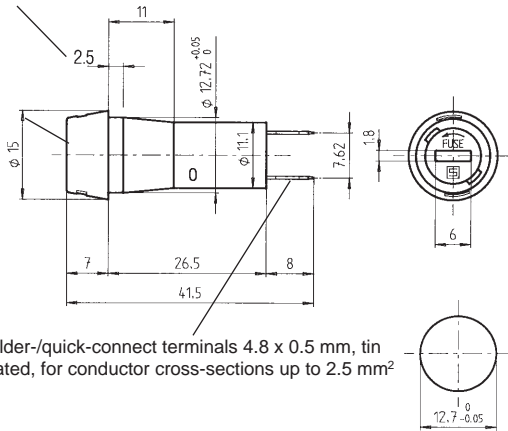

Important note

The potting compound may have an major influence on the thermal behavior of the fuseholder. It is therefore necessary to check the admissible temperatures surface.

Standards

IEC 60127-6 (formerly IEC 257),
EN 60127-6 (formerly EN 60257),
UL 512, CSA C22.2-39

Derating curve

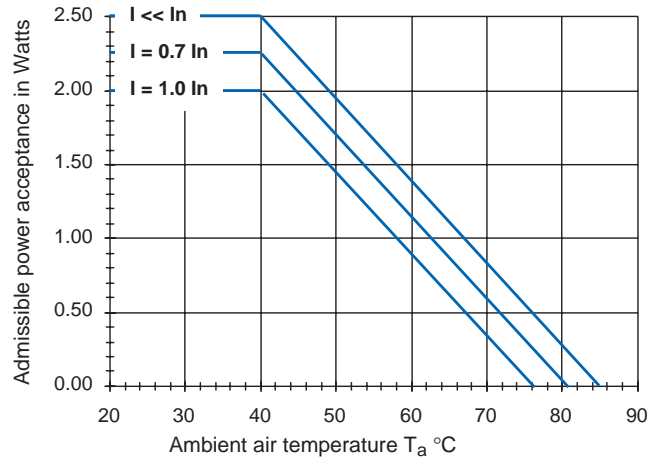

- bayonet type fuse carrier, slotted
- solder-/quick-connect terminals: 4.8 x 0.5 mm
- degree of protection IP40 from frontside according to IEC 60529
- sealed from the rear
- suitable for equipment with protection classes I and II according to IEC 60536

Approvals, Patents

UL recognition (16 A/250 V) File #E39328
 CSA certification (16 A/250 V) File #LR38467
 VDE approval (10 A/250 V) File #77570

Patents in U.S. (No. 4,453,794/4,536,054) and in further countries

Order Numbers (see page 102 for fuses)

FPG 3101.0060 Fuseholder complete with fuse carrier (slotted, IP 40), black

FPG / FEF Shocksafe Panel Mount Fuseholders for 5 x 20mm Fuses



General standards Built according to UL 512, CSA C22.2-39, DIN/VDE 0820, IEC 257 and 127-6, EN 60257 and 60127-6, SEMKO SS-EN 60257; SEV 3133(FEF)

Insulation resistance More than 10,000 meg-ohms at 500V DC/1 min.

Test voltage 50 Hz for 1 minute; 3 kV between contacts, 4 kV from contacts to panel

Contact Resistance Less than .005 ohm at 20 millivolts

Ambient temperatures T_{amb} -40° C to +85° C in function of P_v

Crossing frequency 60 Hz per IEC 68-2-6, test Fc

Vibration resistance 10-500 Hz; .03 inch (0.75mm) constant amplitude or 10 G constant acceleration

Environmental sealing protection IP 40 or 67 per IEC 529/DIN 40050

Body material FPG: temp. resistant thermoplastic (UL 94V-O)
FEF: thermoset (UL 94V-O)

Contact material Brass, tin-plated

Patents U.S.

Options FPG: white or grey body; fuseholder without hexnut

Sealed (IP 67) or unsealed; .187" easy access solder/quick-connect terminals



FPG

FPG

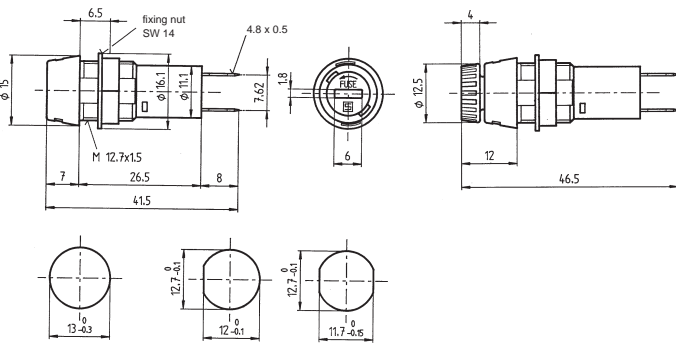

Solder terminals



FEF

FEF

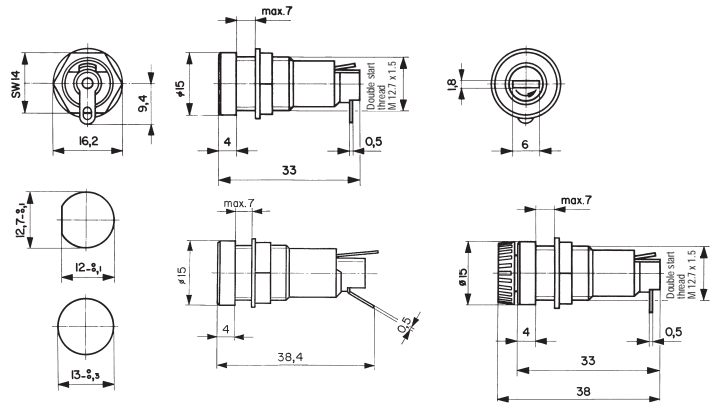

- bayonet fuse carrier – slotted or finger grip
- solder/quick-connect terminals .187 x .020" (4.8 x 0.5mm)
- anti-rotation protection (use "D" cut-out)
- **environmental sealing protection** IP 40 (sealed from the back) or 67 (sealed from the front and back) per IEC 529/DIN 40050
- max. power dissipation 4 watts, according to IEC 127-6. For additional values P_v in function of T_{amb} , see page 5.

- bayonet fuse carrier – slotted or finger grip
- solder terminals (end terminal 45° or 90°)
- anti-rotation protection (use "D" cut-out)
- **environmental sealing protection** IP 40 per IEC 529/DIN 40050
- max. power dissipation 4.5 watts, according to IEC 127-6. For additional values P_v in function of T_{amb} , see page 5.

UL recognition (16A/250V) File #E39328
 CSA certification (16A/250V) File #LR38456
 VDE approval (10A/250V) File #77570
 SEMKO approval (10A/250V) } File numbers on request
 SEV approval (10A/250V) }

UL recognition (10A/250V) File #E39328
 CSA certification (10A/250V) File #LR38456
 VDE approval (10A/250V) File #8596, expert report
 SEMKO approval (6.3A/250V) } File numbers on request
 SEV approval (10A/250V) }
 SETI approval (6.3A/250V) }
 CS certification (10A/250V) }

Order Numbers (see page 102 for fuses)

FPG 3101.0010 Complete fuseholder with fuse carrier (slotted)
FPG 3101.0015 Complete fuseholder with fuse carrier (finger grip)
 FPG 3101.7011 Fuse carrier – slotted (spare part only)
 FPG 3101.7511 Fuse carrier – finger grip (spare part only)

Sealed version – sealed from the front and back

FPG 3101.0110 Complete fuseholder with fuse carrier (slotted, IP 67)
FPG 3101.0115 Complete fuseholder with fuse carrier (finger grip, IP 67)
 FPG 3101.7021 Fuse carrier – slotted (IP 67, spare part only)
 FPG 3101.7521 Fuse carrier – finger grip (IP 67, spare part only)

Accessories: see page 93 for spare plastic or metal nut

FEF 0031.1081 Complete fuseholder with fuse carrier (slotted) solder terminals with 90° end terminal
FEF 0031.1085 Complete fuseholder with fuse carrier (slotted) solder terminals with 45° end terminal
FEF 0031.1907 Complete fuseholder with fuse carrier (finger grip) solder terminals with 90° end terminal
 FEK 0031.3555 Fuse carrier – slotted (spare part only)
 FEK 0031.3560 Fuse carrier – finger grip (spare part only)

Accessories: see page 93 for spare plastic or metal nut

FIO / FIN Shocksafe Panel Mount Fuseholders for 5 x 20mm Fuses



General standards Built according to UL 512, CSA C22.2-39, DIN/VDE 0820, IEC 257 and 127-6, EN 60257 and 60127-6, SEMKO SS-EN 60257; SEV 3133

Insulation resistance FIO: more than 100 meg-ohms at 500V DC
FIN: more than 10,000 meg-ohms at 500V DC

Test voltage 50 Hz for 1 minute; > 3 kV between contacts, > 4 kV from contacts to panel (6 mm)

Contact Resistance Less than .005 ohm at 20 millivolts

Ambient temperatures T_{amb} -25° C to +85° C in function of P_v

Vibration resistance FIO: 10-500 Hz; .03 inch (0.75mm) constant amplitude or 10 G constant acceleration
60 Hz per IEC 68-2-6, test Fc

Crossing frequency 60 Hz per IEC 68-2-6, test Fc

Environmental sealing protection IP 40/65/67 per IEC 529/DIN 40050

Body material Thermoset (UL 94V-O)

Contact material Brass, tin-plated

Sealed from the front (IP 65) or unsealed .110" solder/quick-connect terminals



FIO

Sealed from the front and back (IP 67) .110" solder/quick-connect terminals



FIN

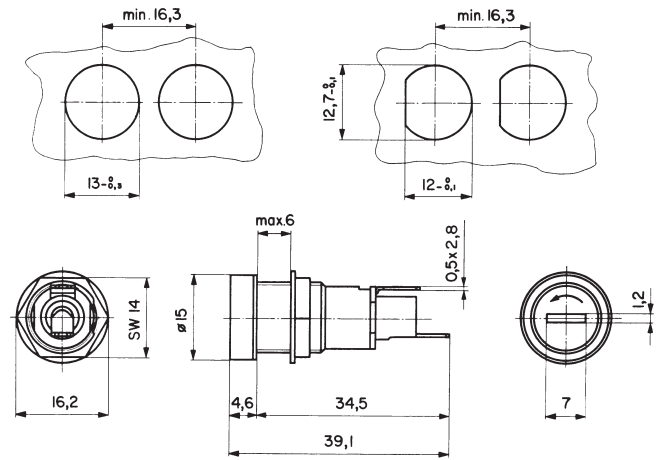
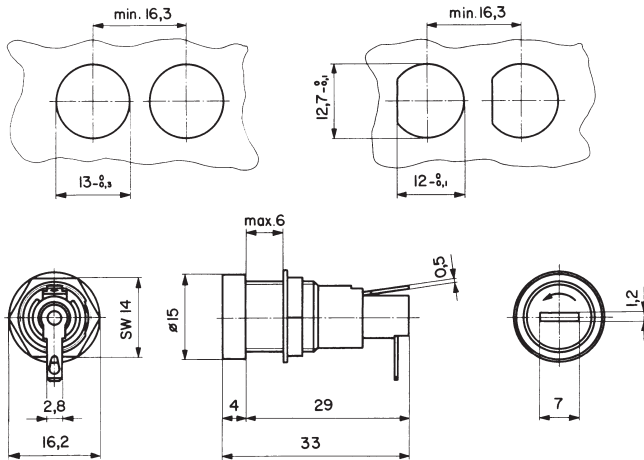

- screw type fuse carrier – slotted
- solder/quick-connect terminals .110 x .020" (2.8 x 0.5mm)
- anti-rotation protection (use "D" cut-out)
- **environmental sealing protection** IP 40 or 65 (sealed from the front), per IEC 529/DIN 40050
- max. power dissipation 2.8 watts, according to IEC 127-6. For additional values P_v in function of T_{amb} , see page 5.

UL	recognition	(10A/250V)	File #E39328
CSA	certification	(10A/250V)	File #LR38456
VDE	approval	(6.3A/250V)	File #1769, expert report
SEMKO	approval	(6.3A/250V)	} File numbers on request
SEV	approval	(6.3A/250V)	
SETI	approval	(6.3A/250V)	
CS	certification	(6.3A/250V)	

- screw type fuse carrier – slotted
- solder/quick-connect terminals .110 x .020" (2.8 x 0.5mm)
- anti-rotation protection (use "D" cut-out)
- **environmental sealing protection** IP 67 (sealed from the front and back), per IEC 529/DIN 40050
- max. power dissipation 2.8 watts, according to IEC 127-6. For additional values P_v in function of T_{amb} , see page 5.

UL	recognition	(10A/250V)	File #E39328
CSA	certification	(10A/250V)	File #LR38456
VDE	approval	(6.3A/250V)	File #1769, expert report
SEMKO	approval	(6.3A/250V)	} File numbers on request
SEV	approval	(6.3A/250V)	
SETI	approval	(6.3A/250V)	
CS	certification	(6.3A/250V)	

Order Numbers (see page 102 for fuses)

FIO 0031.1381 Complete IP40 fuseholder/carrier, end terminal 30°
FIO 0031.1383 Complete IP40 fuseholder/carrier, end terminal 90°
FEK 0031.1372 Fuse carrier (IP 40, spare part only)

Sealed version – sealed from the front

FIO 0031.1361 Complete IP65 fuseholder/carrier, end terminal 30°
FIO 0031.1363 Complete IP65 fuseholder/carrier, end terminal 90°
FEK 0031.1371 Fuse carrier (IP 65, spare part only)

Sealed from the front and back

FIN 0031.1351 Complete IP67 fuseholder/carrier, end terminal straight
FIN 0031.1353 Complete IP67 fuseholder/carrier, end terminal 90°
FEK 0031.1371 Fuse carrier (IP 67, spare part only)

Accessories: See page 93 for square flange, anti-rotation washer, spare plastic or metal nut, face plates

FPG / FEF Shocksafe Snap-in Mount Fuseholders for 5 x 20mm Fuses



General standards Built according to UL 512, CSA C22.2-39, DIN/VDE 0820, IEC 257 and 127-6, EN 60257 and 60127-6, SEMKO SS-EN 60257; SEV 3133(FEF)

Insulation resistance More than 10,000 meg-ohms at 500V DC/1 min.

Test voltage 50 Hz for 1 minute; 3 kV between contacts, 4 kV from contacts to panel

Contact Resistance Less than .005 ohm at 20 millivolts

Ambient temperatures T_{amb} -40° C to +85° C in function of P_v

Crossing frequency 60 Hz per IEC 68-2-6, test Fc

Vibration resistance 10-500 Hz; .03 inch (0.75mm) constant amplitude or 10 G constant acceleration

Environmental sealing protection IP 40 per IEC 529/DIN 40050

Body material FPG: temp. resistant thermoplastic (UL 94V-O)
FEF: Thermoset (UL 94V-O)

Contact material Brass, tin-plated

Patents U.S.

Options FPG: white body; fuseholder without hexnut

.187" easy access solder/quick-connect terminals



.110" solder/quick-connect or solder terminals

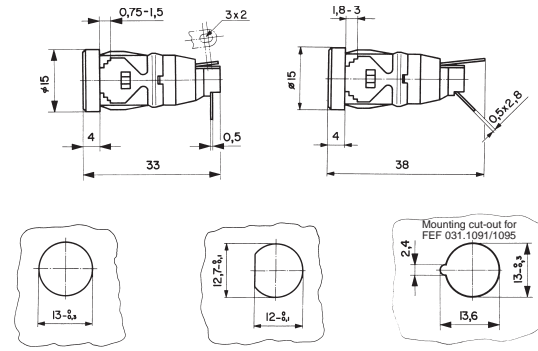
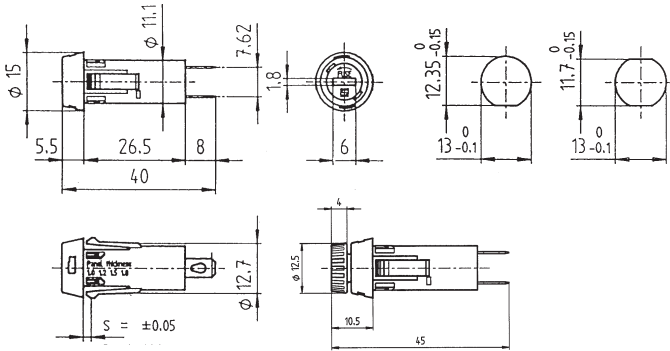

- for panel thickness 1.0 – 3.0mm
- bayonet fuse carrier – slotted or finger grip
- solder/quick-connect terminals .187 x .020" (4.8 x 0.5mm)
- anti-rotation protection (use "D" cut-out)
- environmental sealing protection IP 40 (sealed from the back) per IEC 529/DIN 40050
- max. power dissipation 4 watts, according to IEC 127-6. For additional values P_v in function of T_{amb} , see page 5.

- for panel thickness 0.75 – 3.0mm
- bayonet fuse carrier – slotted (for finger grip style fuse carrier, use FPG)
- solder (90° end terminal) or solder/quick-connect terminals .110 x .020" (2.8 x 0.5mm; end terminal 45° or 90°)
- anti-rotation protection (use "D" or "notched" cut-out)
- environmental sealing protection IP 40 per IEC 529/DIN 40050
- max. power dissipation 4.5 watts, according to IEC 127-6. For additional values P_v in function of T_{amb} , see page 5.

UL recognition (16A/250V) File #E39328
 CSA certification (16A/250V) File #LR38456
 VDE approval (10A/250V) File #77570
 SEMKO approval (10A/250V) } File numbers on request
 SEV approval (10A/250V) }

UL recognition (10A/250V) File #E39328
 CSA* certification (10A/250V) File #LR38456
 VDE approval (10A/250V) File #8596, expert report
 SEMKO approval (6.3A/250V) } File numbers on request
 SEV approval (10A/250V) }
 SETI** approval (6.3A/250V) }
 CS certification (10A/250V) }

* CSA data is only valid for panels made of insulating material
 ** excludes FEF 0031.1161 / 1165

Order Numbers (see page 102 for fuses)

Panel thickness 1.0 – 1.8 mm
FPG 3101.0030 Complete fuseholder with fuse carrier (slotted)
FPG 3101.0035 Complete fuseholder with fuse carrier (finger grip)

Panel thickness 2.0 – 3.0 mm
FPG 3101.0031 Complete fuseholder with fuse carrier (slotted)
FPG 3101.0036 Complete fuseholder with fuse carrier (finger grip)

FPG 3101.8011 Fuse carrier – slotted (spare part only)
 FPG 3101.8511 Fuse carrier – finger grip (spare part only)

Panel thickness 0.75 – 1.5 mm
FEF 0031.1091 Complete fuseholder with fuse carrier (slotted); solder terminals
FEF 0031.1161 Complete fuseholder with fuse carrier (slotted); solder/quick-connect terminals

Panel thickness 1.8 – 3.0 mm
FEF 0031.1095 Complete fuseholder with fuse carrier (slotted); solder terminals
FEF 0031.1165 Complete fuseholder with fuse carrier (slotted); solder/quick-connect terminals

FEK 0031.3555 Fuse carrier – slotted (spare part only)

FPG Shocksafe Rear Panel Mount Fuseholders For 5 x 20mm Fuses



General standards Built according to UL 512, CSA C22.2-39, DIN/VDE 0820, IEC 257 and 127-6, EN 60257 and 60127-6, SEMKO SS-EN 60257

Insulation resistance More than 10,000 meg-ohms at 500V DC/1 min.

Test voltage 50 Hz for 1 minute; 3 kV between contacts, 4 kV from contacts to 7mm panel

Contact Resistance Less than .005 ohm at 20 millivolts

Ambient temperatures T_{amb} -40° C to +85° C in function of P_v

Vibration resistance 10-500 Hz; .03 inch (0.75mm) constant amplitude or 10 G constant acceleration

Crossing frequency 60 Hz per IEC 68-2-6, test Fc

Environmental sealing protection IP 40 or 67 per IEC 529/DIN 40050

Body material Temperature resistant thermoplastic (UL 94V-O)

Contact material Brass, tin-plated

Patents U.S. and Worldwide

Options White body; fuseholder without hexnut

NEW

Speed assembly – pre-wire terminals before mounting

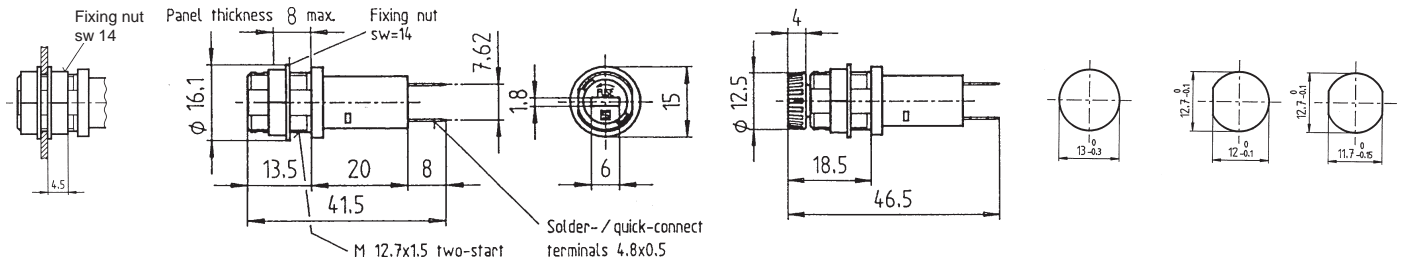
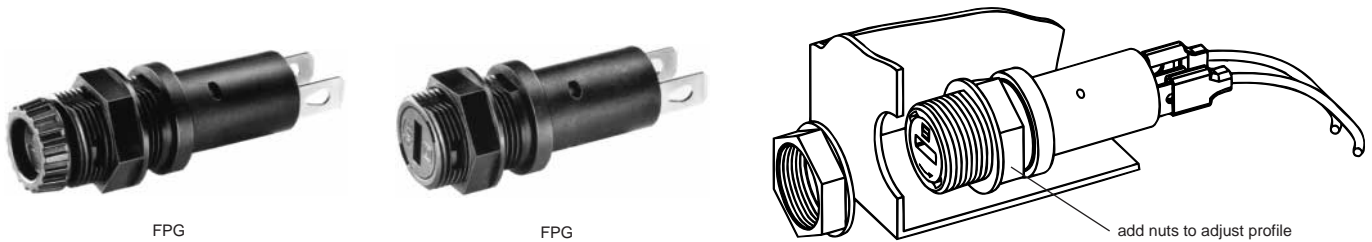

- rear panel, screw-on mounting
- pre-wire terminals before mounting for quicker assembly
- bayonet fuse carrier – slotted or finger grip
- solder/quick-connect terminals .187 x .020" (4.8 x 0.5mm)
- anti-rotation protection (use "D" cut-out)
- **environmental sealing protection** IP 40 (sealed from the back) or 67 (sealed from the front and back) per IEC 529/DIN 40050
- **max. power dissipation 4 watts, according to IEC 127-6. For additional values P_v in function of T_{amb} , see page 5.**

UL	recognition	(16A/250V)	File #E39328
CSA	certification	(16A/250V)	File #LR38456
VDE	approval	(10A/250V)	File #77570
SEMKO	approval	(10A/250V)	} File numbers on request
SEV	approval	(10A/250V)	

Order Numbers (see page 102 for fuses)

FPG 3101.0020 Complete fuseholder with fuse carrier (slotted)
FPG 3101.0025 Complete fuseholder with fuse carrier (finger grip)

FPG 3101.7011 Fuse carrier – slotted (spare part only)
 FPG 3101.7511 Fuse carrier – finger grip (spare part only)

Accessories: See page 93 for spare plastic or metal hexnut

Sealed version – sealed from the front and back
FPG 3101.0120 Complete fuseholder with fuse carrier (slotted, IP 67)
FPG 3101.0125 Complete fuseholder with fuse carrier (finger grip, IP 67)

FPG 3101.7021 Fuse carrier – slotted (IP 67, spare part only)
 FPG 3101.7521 Fuse carrier –finger grip (IP 67, spare part only)

Accessories: See page 93 for spare plastic or metal hexnut

FEU Shocksafe Panel Mount Fuseholders for 1/4 x 1 1/4" or 5 x 20mm Fuses



General standards Built according to UL 512, CSA C22.2-39, DIN/VDE 0820, IEC 257 and 127-6, EN 60257 and 60127-6, SEMKO SS-EN 60257, SEV 3133

Insulation resistance More than 10,000 meg-ohms at 500V DC / 1 min.

Test voltage 50 Hz for 1 minute; 3 kV between contacts, 4 kV from contacts to 7mm panel

Contact Resistance Less than .005 ohm at 20 millivolts

Ambient temperatures T_{amb} -40° C to +85° C in function of P_v

Vibration resistance 10-500 Hz; .03 inch (0.75mm) constant amplitude or 10 G constant acceleration

Crossing frequency 60 Hz per IEC 68-2-6, test Fc

Environmental sealing protection IP 40 per IEC 529/DIN 40050

Body material Temperature resistant thermoplastic (UL 94V-O)

Contact material Brass, tin-plated

Patents U.S.

.187" quick-connect terminals

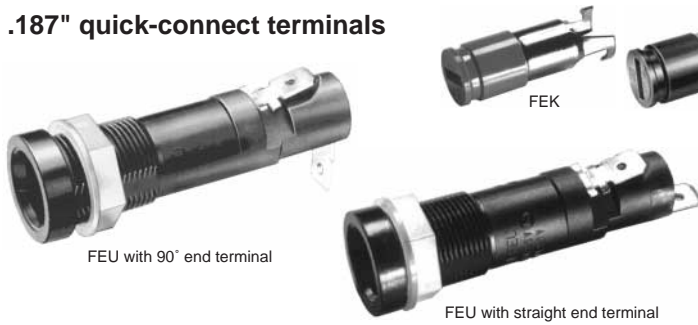

Solder terminals

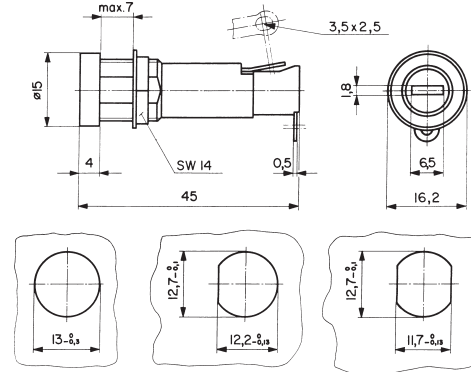
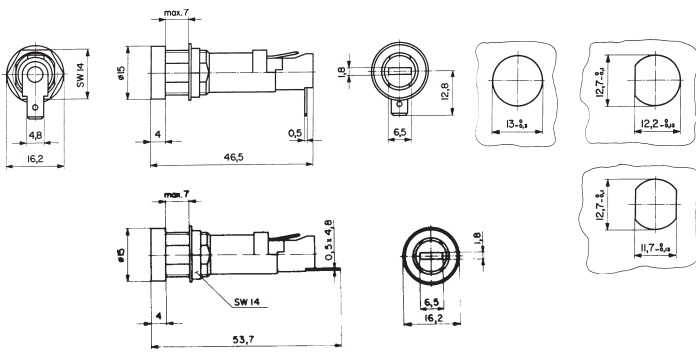

- low profile international fuseholder
- bayonet fuse carrier – finger grip or slotted
- quick-connect terminals .187 x .020" (4.8 x 0.5mm)
- anti-rotation protection (use "D" cut-out)
- mounting hole: 12.7 mm (0.5")
- max. power dissipation 5 watts (using 1/4 x 1 1/4" fuse); 4.5 watts (using 5x20mm fuse), according to IEC 127-6. For **additional values P_v** in function of T_{amb} , see page 5.

- low profile international fuseholder
- bayonet fuse carrier – finger grip or slotted
- solder terminals .138 x .10" (3.5 x 2.5mm)
- anti-rotation protection (use "D" cut-out)
- mounting hole 12.7 mm (0.5")
- max. power dissipation 5 watts (using 1/4 x 1 1/4" fuse); 4.5 watts (using 5x20mm fuse), according to IEC 127-6. For **additional values P_v** in function of T_{amb} , see page 5.

UL	recognition	(20A/250V)	File #E39328
CSA	certification	(16A/250V)	File #LR38456
VDE	approval	(10A/250V)	File #1691, expert report
SEMKO	approval	(10A/250V)	} File numbers on request
SEV	approval	(10A/250V)	
CS	certification	(10A/250V)	

UL	recognition	(20A/250V)	File #E 39328
CSA	certification	(16A/250V)	File #LR38456
VDE	approval	(10A/250V)	File #1691, expert report
SEMKO	approval	(10A/250V)	} File numbers on request
SEV	approval	(10A/250V)	
SETI	approval	(6.3A/250V)	
CS	certification	(10A/250V)	

Order Numbers (see page 102 for fuses)

Complete fuseholder with fuse carrier (slotted/grey for 1/4 x 1 1/4" fuse)

FEU 0031.1699 With 90° end terminal

FEU 0031.1764 With straight end terminal

Complete fuseholder with fuse carrier (slotted/black for 5x20mm fuse)

FEU 0031.1706 With 90° end terminal

FEU 0031.1754 With straight end terminal

Complete fuseholder with fuse carrier (finger grip/black for 1/4 x 1 1/4" fuse)

FEU 0031.1761 With 90° end terminal

FEU 0031.1765 With straight end terminal

FEU 0031.1693 Fuseholder body only – 90° end terminal

FEU 0031.1694 Fuseholder body only – straight end terminal

FEK 0031.1666 Fuse carrier only – slotted/grey for 1/4 x 1 1/4" fuse

FEK 0031.1663 Fuse carrier only – slotted/black for 5x20mm fuse

FEK 0031.1667 Fuse carrier only – finger grip/black for 1/4 x 1 1/4" fuse

FEU 0031.1680 Complete fuseholder with fuse carrier (slotted/grey for 1/4 x 1 1/4" fuse)

FEU 0031.1753 Complete fuseholder with fuse carrier (slotted/black for 5x20mm fuse)

FEU 0031.1755 Complete fuseholder with fuse carrier (finger grip/black for 1/4 x 1 1/4" fuse)

FEU 0031.1673 Fuseholder body only

FEK 0031.1666 Fuse carrier only – slotted/grey for 1/4 x 1 1/4" fuse

FEK 0031.1663 Fuse carrier only – slotted/black for 5x20mm fuse

FEK 0031.1667 Fuse carrier only – finger grip/black for 1/4 x 1 1/4" fuse

Accessories: see page 93 for square flange, anti-rotation washer, spare plastic or metal nut, face plates, insulation cover

FEU Shocksafe Panel Mount Fuseholders for 1/4 x 1 1/4" or 5 x 20mm Fuses

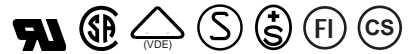

General standards Built according to UL 512, CSA C22.2-39, DIN/VDE 0820, IEC 257 and 127-6, EN 60257 and 60127-6, SEMKO SS-EN 60257, SEV 3133

Insulation resistance More than 10,000 meg-ohms at 500V DC / 1 min.

Test voltage 50 Hz for 1 minute; 3 kV between contacts, 4 kV from contacts to 7mm panel

Contact Resistance Less than .005 ohm at 20 millivolts

Ambient temperatures T_{amb} -40° C to +85° C in function of P_v

Vibration resistance 10-500 Hz; .03 inch (0.75mm) constant amplitude or 10 G constant acceleration

Crossing frequency 60 Hz per IEC 68-2-6, test Fc

Environmental sealing protection IP 40 per IEC 529/DIN 40050

Body material Temperature resistant thermoplastic (UL 94V-O)

Contact material Brass, tin-plated

Patents U.S.

.187" quick-connect terminals



Solder terminals

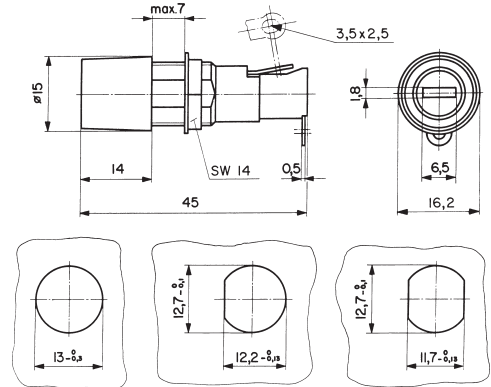
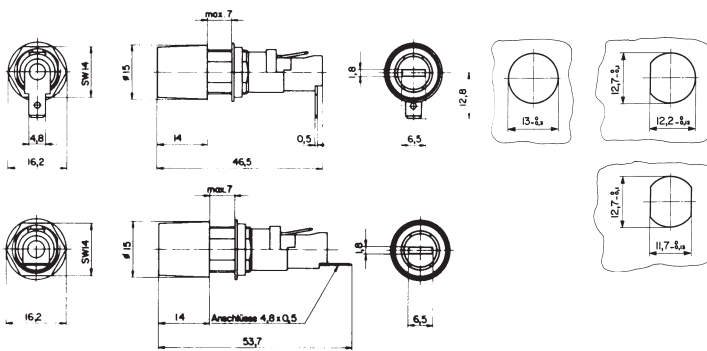

- high profile international fuseholder
- bayonet fuse carrier – slotted
- quick-connect terminals .187 x .020" (4.8 x 0.5mm)
- anti-rotation protection (use "D" cut-out)
- mounting hole: 12.7 mm (0.5")
- max. power dissipation 5 watts (using 1/4 x 1 1/4" fuse); 4.5 watts (using 5x20mm fuse), according to IEC 127-6. For **additional values P_v in function of T_{amb}**, see page 5.

- high profile international fuseholder
- bayonet fuse carrier – slotted
- solder terminals .138 x .10" (3.5 x 2.5mm)
- anti-rotation protection (use "D" cut-out)
- mounting hole 12.7 mm (0.5")
- max. power dissipation 5 watts (using 1/4 x 1 1/4" fuse); 4.5 watts (using 5x20mm fuse), according to IEC 127-6. For **additional values P_v in function of T_{amb}**, see page 5.

UL recognition (20A/250V) File #E 39328
 CSA certification (16A/250V) File #LR38456
 VDE approval (10A/250V) File #1691, expert report
 SEMKO approval (10A/250V) } File numbers on request
 SEV approval (10A/250V) }
 CS certification (10A/250V) }

UL recognition (20A/250V) File #E39328
 CSA certification (16A/250V) File #LR38456
 VDE approval (10A/250V) File #1691, expert report
 SEMKO approval (10A/250V) } File numbers on request
 SEV approval (10A/250V) }
 CS certification (10A/250V) }

Order Numbers (see page 102 for fuses)

Complete fuseholder with fuse carrier (slotted/grey for 1/4 x 1 1/4" fuse)
FEU 0031.1768 With 90° end terminal
FEU 0031.1752 With straight end terminal
Complete fuseholder with fuse carrier (slotted/black for 5x20mm fuse)
FEU 0031.1767 With 90° end terminal
FEU 0031.1769 With straight end terminal

FEU 0031.1695 Fuseholder body only – 90° end terminal
 FEU 0031.1696 Fuseholder body only – straight end terminal
 FEK 0031.1666 Fuse carrier only – slotted/grey for 1/4 x 1 1/4" fuse
 FEK 0031.1663 Fuse carrier only – slotted/black for 5x20mm fuse

FEU 0031.1659 Complete fuseholder with fuse carrier (slotted/grey for 1/4 x 1 1/4" fuse)
FEU 0031.1751 Complete fuseholder with fuse carrier (slotted/black for 5x20mm fuse)
 FEU 0031.1653 Fuseholder body only
 FEK 0031.1666 Fuse carrier only – slotted/grey for 1/4 x 1 1/4" fuse
 FEK 0031.1663 Fuse carrier only – slotted/black for 5x20mm fuse

Accessories: see page 93 for square flange, anti-rotation washer, spare plastic or metal nut, face plates, insulation cover

FEU Shocksafe Panel Mount Fuseholders for 1/4 x 1 1/4" or 5 x 20mm Fuses



General standards Built according to UL 512, CSA C22.2-39, DIN/VDE 0820, IEC 257 and 127-6, EN 60257 and 60127-6, SEMKO SS-EN 60257, SEV 3133

Medical standards (FEU 031.1681 only) Slotted fuse carrier meets tool-only accessibility requirements of medical equipment standards IEC 601-1, BS 5724 part 1, DIN/VDE 0750 part 1

Insulation resistance More than 10,000 meg-ohms at 500V DC / 1 min.

Test voltage 50 Hz for 1 minute; 3 kV between contacts, 4 kV from contacts to 7mm panel

Contact Resistance Less than .005 ohm at 20 millivolts

Ambient temperatures T_{amb} -40° C to +85° C in function of P_v

Vibration resistance 10-500 Hz; .03 inch (0.75mm) constant amplitude or 10 G constant acceleration 60 Hz per IEC 68-2-6, test Fc

Crossing frequency 60 Hz per IEC 68-2-6, test Fc

Environmental sealing protection IP 40 per IEC 529/DIN 40050

Body material Temperature resistant thermoplastic (UL 94V-O)

Contact material Brass, tin-plated

Patents U.S.

Recessed fuse carrier

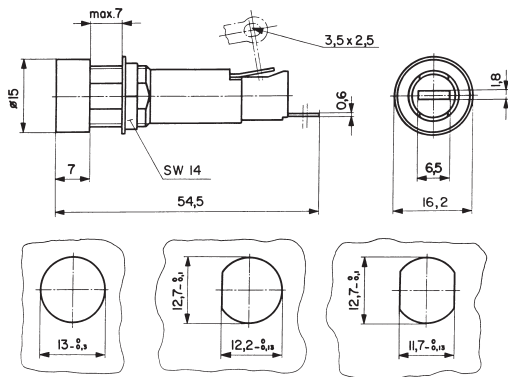
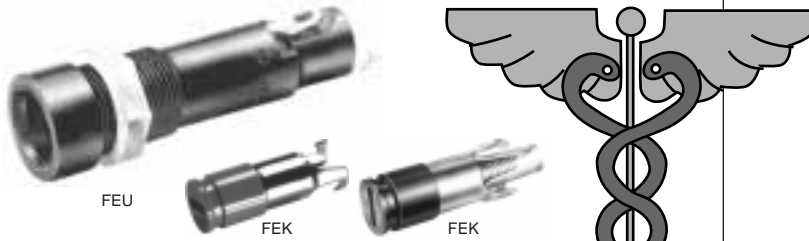

Finger grip fuse carrier

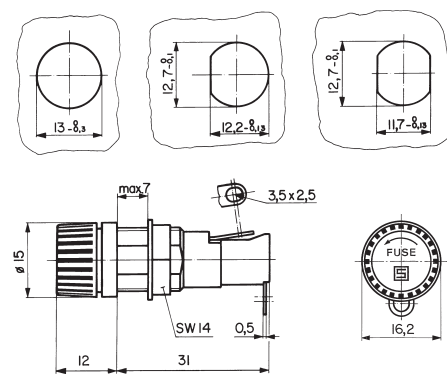

- low profile international fuseholder with recessed fuse carrier (for **medical grade fuseholder with captive fuse carrier**, see series FBS, page 86)
- bayonet fuse carrier – slotted
- solder terminals .138 x .10" (3.5 x 2.5mm)
- anti-rotation protection (use "D" cut-out)
- mounting hole 12.7 mm (0.5")
- max. power dissipation 5 watts (using 1/4 x 1 1/4" fuse); 4.5 watts (using 5x20mm fuse), according to IEC 127-6. For **additional values P_v in function of T_{amb}** , see page 4.

UL	recognition	(20A/250V)	File #E 39328
CSA	certification	(16A/250V)	File #LR38456
VDE	approval	(10A/250V)	File #1691, expert report
SEMKO	approval	(10A/250V)	} File numbers on request
SEV	approval	(10A/250V)	
CS	certification	(10A/250V)	

- low profile international fuseholder
- bayonet fuse carrier – finger grip
- solder terminals .138 x .10" (3.5 x 2.5mm)
- anti-rotation protection (use "D" cut-out)
- mounting hole: 12.7 mm (0.5")
- max. power dissipation 4.2 watts (using 1/4 x 1 1/4" fuse); 4.5 watts (using 5x20mm fuse), according to IEC 127-6. For **additional values P_v in function of T_{amb}** , see page 4.

UL	recognition	(20A/250V)	File #E39328
CSA	certification	(16A/250V)	File #LR38456
VDE	approval	(10A/250V)	File #1691, expert report
SEMKO	approval	(10A/250V)	} File numbers on request
SEV	approval	(10A/250V)	
CS	certification	(10A/250V)	

Order Numbers (see page 102 for fuses)

FEU 0031.1758 Complete fuseholder with fuse carrier (slotted/grey for 1/4 x 1 1/4" fuse)

FEU 0031.1757 Complete fuseholder with fuse carrier (slotted/black for 5x20mm fuse)

FAU 0031.1681 Fuseholder body only

FEK 0031.1666 Fuse carrier only – slotted/grey for 1/4 x 1 1/4" fuse

FEK 0031.1663 Fuse carrier only – slotted/black for 5x20mm fuse

FEU 0031.1803 Complete fuseholder with fuse carrier (finger grip/black for 5x20mm fuse)

FEU 0031.1804 Complete fuseholder with fuse carrier (finger grip/black for 1/4 x 1 1/4" fuse)

FEU 0031.1801 Fuseholder body only

FEU 0031.1811 Fuse carrier for 5x20mm fuses

FEU 0031.1812 Fuse carrier for 1/4 x 1 1/4" fuses

Accessories: see page 93 for square flange, anti-rotation washer, spare plastic or metal nut, face plates, insulation cover

FEC Shocksafe Panel Mount Fuseholders for 1/4 x 1 1/4" or 5 x 20mm Fuses



General standards Built according to UL 512, CSA C22.2-39, DIN/VDE 0820, IEC 257 and 127-6, EN 60257 and 60127-6, SEMKO SS-EN 60257, SEV 3133

Insulation resistance More than 10,000 meg-ohms at 500V DC/1 min.

Test voltage 50 Hz for 1 minute; 3 kV between contacts, 4 kV from contacts to panel (8 mm)

Contact Resistance Less than .005 ohm at 20 millivolts

Ambient temperatures T_{amb} -40° C to +85° C in function of P_v

Vibration resistance 10-500 Hz; .03 inch (0.75mm) constant amplitude or 10 G constant acceleration

Crossing frequency 60 Hz per IEC 68-2-6, test Fc

Environmental sealing protection IP 40 per IEC 529/DIN 40050

Body material Thermoset (UL 94V-O)

Contact material Brass, tin-plated

.250" solder/quick-connect terminals



FEC 031.1631



FEK 031.1611 / 031.1613



FEK 031.1616

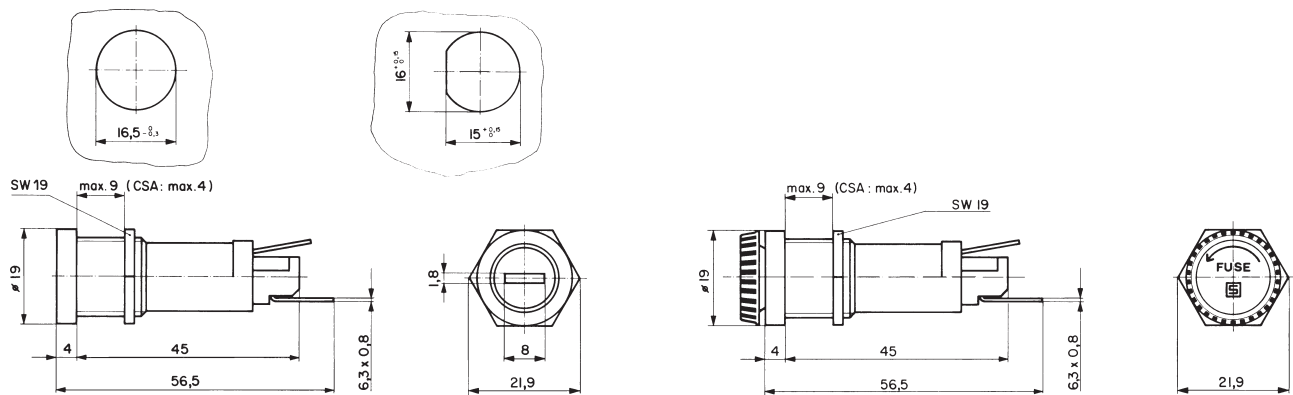

- bayonet fuse carrier – finger grip or slotted
- solder/quick-connect terminals .250 x .032" (6.3 x 0.8mm). Solder terminals available on request.
- anti-rotation protection (use "D" cut-out)
- **environmental sealing protection** IP 40 per IEC 529/DIN 40050
- metal nut M16 x 1.5, double pitch
- max. power dissipation 5 watts (using 5x20mm fuse); 3.2 watts (using 1/4 x 1 1/4" fuse), according to IEC 127-6. For **additional values P_v in function of T_{amb}** , see page 5.

UL	recognition	(20A/500V ¹⁾)	File #39328
CSA	certification	(12A/500V ¹⁾)	File #LR38456
VDE	approval	(10A/500V ¹⁾)	File #45269
SEMKO	approval	(10A/500V ¹⁾)	} File numbers on request
SEV	approval	(10A/500V ¹⁾)	
SETI	approval	(6.3A/250V)	
CS	certification	(10A/250V)	

¹⁾ Fuses according to 250V standards only

Order Numbers (see page 102 for fuses)

- FEC 0031.1631** Fuseholder body
- FEK 0031.1611** Fuse carrier (slotted) for 5 x 20mm fuses
- FEK 0031.1613** Fuse carrier (slotted) for 1/4 x 1 1/4" fuses
- FEK 0031.1616** Fuse carrier (finger grip) for 1/4 x 1 1/4" fuses

0098.0044 Spare metal nut (optional)

Accessories: See page 93 for screw adapters for quick-connect terminals

FIZ / FUL High Current, Shocksafe Panel Mount Fuseholders for 1/4 x 1 1/4" or 5 x 20mm Fuses



General standards Built according to UL 512, CSA C22.2-39, DIN/VDE 0820, IEC 257 and 127-6, EN 60257 and 60127-6, SEMKO SS-EN 60257, SEV 3133

Insulation resistance Test voltage More than 10,000 meg-ohms at 500V DC/1 min. 50 Hz for 1 minute; 3 kV between contacts, 4 kV from contacts to panel (8 mm)

Contact Resistance Less than .005 ohm at 20 millivolts

Ambient temperatures T_{amb} -40° C to +85° C in function of P_v

Vibration resistance 10-500 Hz; .03 inch (0.75mm) constant amplitude or 10 G constant acceleration

Crossing frequency 60 Hz per IEC 68-2-6, test Fc

Environmental sealing protection IP 40 or 67 per IEC 529/DIN 40040

Body material Thermoset (UL 94V-O)

Contact material Brass, tin-plated

Rated 16A / 30A – for 5 x 20mm fuses



FIZ

Rated 16A-30A – for 1/4 x 1 1/4" or 5 x 20mm fuses



FUL

FEK

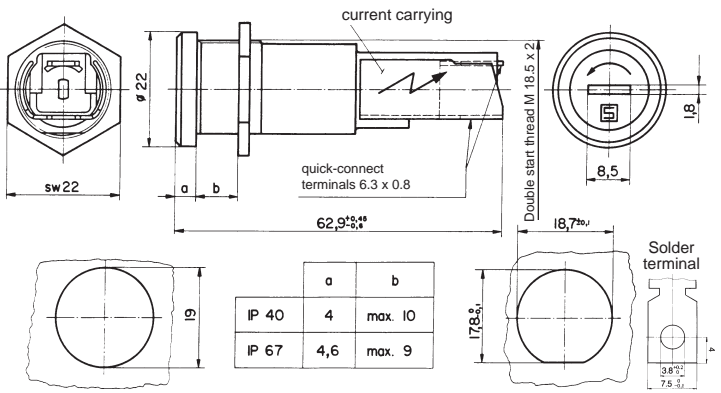
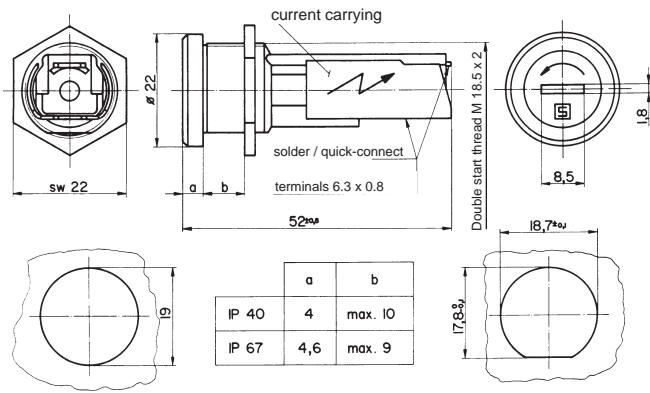

- screw type fuse carrier (slotted)
- solder / quick-connect terminals .250 x .032" (6.3 x 0.8mm) according to NEMA DC-2
- anti-rotation protection (use "D" cut-out)
- **environmental sealing protection** IP 40 or 67 (watertight from front side according to IEC 529)
- max. power dissipation 4.2 watts, according to IEC 127-6. For **additional values P_v in function of T_{amb}** , see page 5.

UL recognition (30A/250V) File #E 39328
 CSA certification (30A/250V) File #LR 38456
 VDE approval (16A/250V) File #41424
 SEMKO approval (16A/250V)
 SEV approval (16A/250V)
 SETI approval (6.3A/250V)
 CS certification (16A/250V)

} File numbers on request

- screw type fuse carrier (slotted)
- quick-connect terminals .250 x .032" (6.3 x 0.8mm) according to NEMA DC-2 (solder terminals optional)
- anti-rotation protection (use "D" cut-out)
- **environmental sealing protection** IP 40 or 67 (watertight from front side according to IEC 529)
- max. power dissipation 4.6 watts (using 1/4 x 1 1/4" fuse); 5.2 watts (using 5x20mm fuse), according to IEC 127-6. For **additional values P_v in function of T_{amb}** , see page 5.

UL recognition (30A/250V) File #E 39328
 CSA certification (30A/250V) File #LR 38456
 VDE approval (16A/250V) File #41424
 SEMKO approval (16A/250V)
 SEV approval (16A/250V)
 CS certification (16A/250V)

} File numbers on request

Order Numbers (see page 102 for fuses)

FIZ 0031.2201 Complete fuseholder with fuse carrier, IP 67 (watertight)
FIZ 0031.2203 Complete fuseholder with fuse carrier, IP 40

FEK 0031.2220 Fuse carrier, IP 67 watertight (spare part only)
FEK 0031.2221 Fuse carrier, IP 40 (spare part only)
 0583.0012 Spare metal nut (optional)

FUL 0031.2303 Fuseholder body only, IP 67 (watertight), solder terminals
FUL 0031.2304 Fuseholder body only, IP 67 (watertight), quick-connect terminals
FUL 0031.2307 Fuseholder body only, IP 40, solder terminals
FUL 0031.2308 Fuseholder body only, IP 40, quick-connect terminals
FEK 0031.2320 Fuse carrier for 1/4 x 1 1/4" fuses, IP 67 (watertight)
FEK 0031.2321 Fuse carrier for 1/4 x 1 1/4" fuses, IP 40
FEK 0031.2322 Fuse carrier for 5 x 20mm fuses, IP 67 (watertight)
FEK 0031.2323 Fuse carrier for 5 x 20mm fuses, IP 40
 0098.0042 Spare metal nut (optional)

Accessories: See page 93 for insulation cover and screw adapter for quick-connect terminals

FPG / FAB Shocksafe PCB Mount Fuseholders For 5 x 20mm Fuses

General standards Built according to UL 512, CSA C22.2-39, DIN/VDE 0820, IEC 257 and 127-6, EN 60257 and 60127-6, SEMKO SS-EN 60257; SEV 3133(FAB)

Insulation resistance More than 10,000 meg-ohms at 500V DC/1 min.

Test voltage 50 Hz for 1 minute; 3 kV between contacts, 4 kV from contacts to 7mm panel

Contact Resistance Less than .005 ohm at 20 millivolts

Ambient temperatures T_{amb} -40° C to +85° C in function of P_v

Crossing frequency 60 Hz per IEC 68-2-6, test Fc

Vibration resistance 10-500 Hz; .03 inch (0.75mm) constant amplitude or 10 G constant acceleration

Environmental sealing protection IP 40 per IEC 529/DIN 40050

Body material FAB: thermoset (UL 94V-O)
FPG: temp. resistant thermoplastic (UL 94V-O)

Contact material Brass, tin-plated

Patents U.S. and Worldwide

Options FPG: white body

Non-conductive center post adds stability

NEW



FPG

FPG

FAB

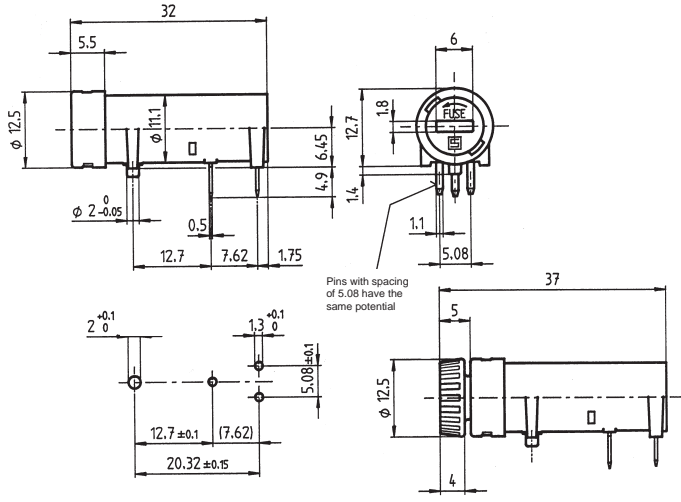

“Kicked” PCB terminals

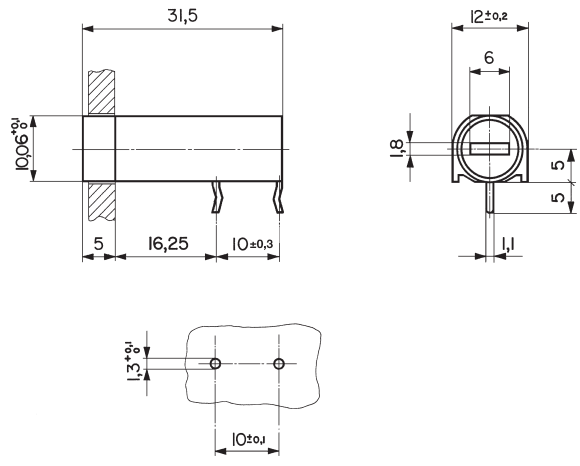

- bayonet fuse carrier – slotted or finger grip
- stand-offs for flux-proofing and ease of cleaning
- solderability: 235° C / 2 sec. (IEC 68-2-20 Test Ta, method 1)
- soldering resistance: 350° C / 5 sec. (IEC 68-2-20 Test Tb, method 1B)
- **environmental sealing protection** IP40 per IEC 529/DIN 40050
- wave solderable and washable in aqueous solutions (sealed from the bottom)
- max. power dissipation 2.5 watts, according to IEC 127-6. For additional values P_v in function of T_{amb} , see page 5.

- bayonet fuse carrier – slotted (for **finger grip style fuse carrier**, use FPG)
- body designed to protrude through panel opening
- stand-offs for flux-proofing and ease of cleaning
- solderability: 235° C / 2 sec. (IEC 68-2-20 Test Ta, method 1)
- soldering resistance: 350° C / 5 sec. (IEC 68-2-20 Test Tb, method 1B)
- **environmental sealing protection** IP40 per IEC 529/DIN 40050
- wave solderable and washable in aqueous solutions
- max. power dissipation 3.2 watts, according to IEC 127-6. For additional values P_v in function of T_{amb} , see page 5.

UL recognition (16A/250V) File #E39328
 CSA certification (16A/250V) File #LR38456
 VDE approval (10A/250V) File #77570
 SEMKO approval (10A/250V) } File numbers on request
 SEV approval (10A/250V) }

UL recognition (12A/250V) File #E39328
 CSA certification (10A/250V) File #LR38456
 VDE approval (6.3A/250V) File #1686, expert report
 SEMKO approval (6.3A/250V) } File numbers on request
 SEV approval (6.3A/250V) }
 SETI approval (6.3A/250V) }
 CS certification (6.3A/250V) }

Order Numbers (see page 102 for fuses)

FPG 3101.0050 Complete fuseholder with fuse carrier (slotted)
FPG 3101.0055 Complete fuseholder with fuse carrier (finger grip)
FPG 3101.8011 Fuse carrier – slotted (spare part only)
FPG 3101.8511 Fuse carrier – finger grip (spare part only)

FAB 0031.3558 Complete fuseholder with fuse carrier
FEK 0031.3555 Fuse carrier (spare part only)

FPG / FAF Shocksafe PCB Mount Fuseholders For 5 x 20mm Fuses

General standards Built according to UL 512, CSA C22.2-39, DIN/VDE 0820, IEC 257 and 127-6, EN 60257 and 60127-6, SEMKO SS-EN 60257; SEV 3133(FAF)

Insulation resistance Test voltage More than 10,000 meg-ohms at 500V DC/1 min. 50 Hz for 1 minute; 3 kV between contacts, 4 kV from contacts to 7mm panel

Contact Resistance Less than .005 ohm at 20 millivolts

Ambient temperatures T_{amb} -40° C to +85° C in function of P_v

Vibration resistance 10-500 Hz; .03 inch (0.75mm) constant amplitude or 10 G constant acceleration

Crossing frequency 60 Hz per IEC 68-2-6, test Fc

Environmental sealing protection IP 40 or 54 per IEC 529/DIN 40050

Body material temperature resistant thermoplastic (UL 94V-O)

Contact material Brass, tin-plated

Patents U.S. and Worldwide

Options FPG: white body

Extra PCB terminals add stability



NEW

Front seal (IP 54) or unsealed

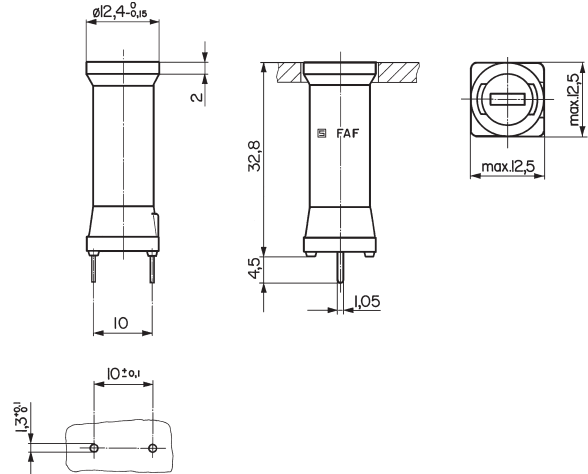
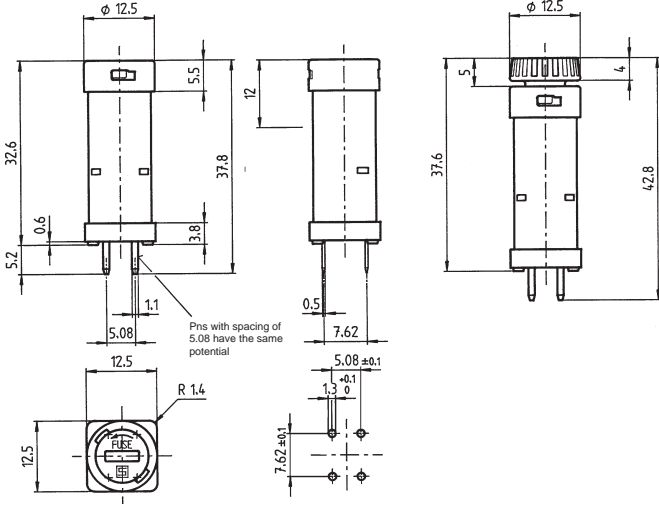

- bayonet fuse carrier – slotted or finger grip
- body designed to protrude through panel opening
- stand-offs for flux-proofing and ease of cleaning
- solderability: 235° C / 2 sec. (IEC 68-2-20 Test Ta, method 1)
- soldering resistance: 350° C / 5 sec. (IEC 68-2-20 Test Tb, method 1B)
- **environmental sealing protection** IP40 per IEC 529/DIN 40050
- wave solderable and washable in aqueous solutions (sealed from the bottom)
- max. power dissipation 2.5 watts, according to IEC 127-6. For **additional values P_v in function of T_{amb}** , see page 5.

- bayonet fuse carrier – slotted (for **finger grip style fuse carrier**, use FPG)
- body designed to protrude through panel opening
- stand-offs for flux-proofing and ease of cleaning
- solderability: 235° C / 2 sec. (IEC 68-2-20 Test Ta, method 1)
- soldering resistance: 350° C / 5 sec. (IEC 68-2-20 Test Tb, method 1B)
- **environmental sealing protection** IP40 / 54 per IEC 529/DIN 40050
- wave solderable and washable in aqueous solutions
- max. power dissipation 3.4 watts, according to IEC 127-6. For **additional values P_v in function of T_{amb}** , see page 5.

UL recognition (16A/250V) File #E39328
 CSA certification (16A/250V) File #LR38456
 VDE approval (10A/250V) File #77570
 SEMKO approval (10A/250V) } File numbers on request
 SEV approval (10A/250V) }

UL recognition (12A/250V) File #E39328
 CSA certification (10A/250V) File #LR38456
 VDE approval (6.3A/250V) File #1698, expert report
 SEMKO approval (6.3A/250V) } File numbers on request
 SEV approval (6.3A/250V) }
 SETI approval (6.3A/250V) }
 CS certification (6.3A/250V) }

Order Numbers (see page 102 for fuses)

FPG 3101.0040 Complete fuseholder with fuse carrier (slotted)
FPG 3101.0045 Complete fuseholder with fuse carrier (finger grip)

FPG 3101.8011 Fuse carrier – slotted (spare part only)
 FPG 3101.8511 Fuse carrier – finger grip (spare part only)

FAF 0031.3751 Complete fuseholder with fuse carrier, IP 40

Sealed version – sealed from the front
FAF 0031.3753 Complete fuseholder with fuse carrier, IP 54

FEK 0031.3555 Fuse carrier, IP 40 (spare part only)
 FEK 0031.3562 Fuse carrier, IP 54 (spare part only)

FAU / FAC Shocksafe PCB Mount Fuseholders for 1/4 x 1 1/4" or 5 x 20mm Fuses



General standards Built according to UL 512, CSA C22.2-39, DIN/VDE 0820, IEC 257 and 127-6, EN 60257 and 60127-6, SEMKO SS-EN 60257, SEV 3133

Insulation resistance More than 10,000 meg-ohms at 500V DC/1 min.

Test voltage 50 Hz for 1 minute; 3 kV between contacts, 4 kV from contacts to panel (5mm FAU, 24mm FAC)

Contact Resistance Less than .005 ohm at 20 millivolts

Ambient temperatures T_{amb} -40° C to +85° C in function of P_v

Vibration resistance 10-500 Hz; .014 inch (0.35mm) constant amplitude or 5 G constant acceleration

Crossing frequency 60 Hz per IEC 68-2-6, test Fc

Environmental sealing protection IP 40 per IEC 529/DIN 40050

Body material Temperature resistant thermoplastic (UL 94V-O)

Contact material Brass, tin-plated

Patents U.S.

"Kicked" PCB terminals

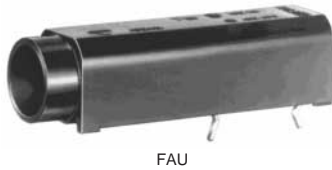

FAU



FEK

FEK

"Kicked" PCB terminals



FAC

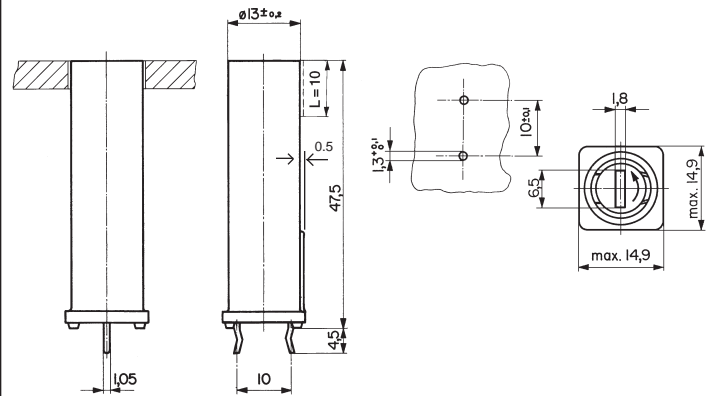
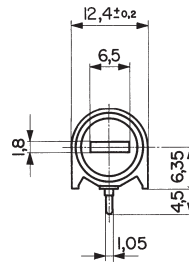
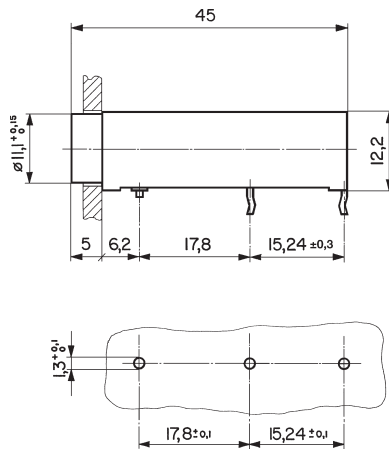

- bayonet fuse carrier – slotted or finger grip
- sleeve designed to protrude through panel opening
- stand-offs for flux-proofing and ease of cleaning
- solderability: 235°C / 2 sec. (IEC 68-2-20 Test Ta, method 1)
- soldering resistance: 350°C / 5 sec. (IEC 68-2-20 Test Tb, method 1B)
- wave solderable and washable in aqueous solutions
- max. power dissipation 4.1 watts (using 1/4 x 1 1/4" fuse); 3.8 watts (using 5x20mm fuse), according to IEC 127-6. For **additional values P_v in function of T_{amb}** , see page 5.

- bayonet fuse carrier – slotted or finger grip
- round body designed to protrude through panel opening
- stand-offs for flux-proofing and ease of cleaning
- solderability: 235°C / 2 sec. (IEC 68-2-20 Test Ta, method 1)
- soldering resistance: 350°C / 5 sec. (IEC 68-2-20 Test Tb, method 1B)
- wave solderable and washable in aqueous solutions
- max. power dissipation 4.5 watts, according to IEC 127-6. For **additional values P_v in function of T_{amb}** , see page 5.

UL recognition (16A/250V) File #E 39328
 CSA certification (16A/250V) File #LR 38456
 VDE approval (10A/250V) File #1688, expert report
 SEMKO approval (6.3A/250V)
 SEV approval (6.3A/250V) } File numbers on request
 SETI approval (6.3A/250V)
 CS certification (6.3A/250V)

UL recognition (16A/250V) File #E 39328
 CSA certification (16A/250V) File #LR 38456
 VDE approval (10A/250V) File #1690, expert report
 SEMKO approval (6.3A/250V)
 SEV approval (6.3A/250V) } File numbers on request
 SETI approval (6.3A/250V)
 CS certification (6.3A/250V)

Order Numbers (see page 102 for fuses)

FAU 0031.3581	Complete fuseholder with fuse carrier (slotted/grey for 1/4 x 1 1/4" fuse)	FAC 0031.3822	Complete fuseholder with fuse carrier (slotted/grey for 1/4 x 1 1/4" fuse)
FAU 0031.3571	Complete fuseholder with fuse carrier (slotted/black for 5x20mm fuse)	FAC 0031.3821	Complete fuseholder with fuse carrier (slotted/black for 5x20mm fuse)
FAU 0031.3583	Complete fuseholder with fuse carrier (finger grip/black for 1/4 x 1 1/4" fuse)	FAC 0031.3823	Complete fuseholder with fuse carrier (finger grip/black for 1/4 x 1 1/4" fuse)
FAU 0031.3577	Fuseholder body only	FAC 0031.3804	Fuseholder body only
FEK 0031.1666	Fuse carrier only – slotted/grey for 1/4 x 1 1/4" fuse	FEK 0031.1666	Fuse carrier only – slotted/grey for 1/4 x 1 1/4" fuse
FEK 0031.1663	Fuse carrier only – slotted/black for 5x20mm fuse	FEK 0031.1663	Fuse carrier only – slotted/black for 5x20mm fuse
FEK 0031.1667	Fuse carrier only – finger grip/black for 1/4 x 1 1/4" fuse	FEK 0031.1667	Fuse carrier only – finger grip/black for 1/4 x 1 1/4" fuse

Accessories: see page 93 for square flange, anti-rotation washer, face plates

FBS Medical Grade, Shockproof Fuseholders for 5 x 20mm Fuses



General standards Built according to UL 512, CSA C22.2-39, DIN/VDE 0820, IEC 257 and 127-6, EN 60257 and 60127-6, SEMKO SS-EN 60257

Medical standards Slotted fuse carrier meets tool-only accessibility requirements of medical equipment standards IEC 601-1, BS 5724 part 1, DIN/VDE 0750 part 1

Test voltage 50 Hz / 1 min.; 3 kV between contacts, 4 kV from contacts to 7mm panel

Ambient temperatures Storage: -25° C to +85° C
Operating: +40° C for touchable surfaces, +85° C for untouchable surfaces

Insulation resistance More than 10,000 meg-ohms at 500VDC / 1 min.

Contact Resistance Less than .005 ohm at 20 millivolts

Vibration resistance 10-500 Hz; .014 inch (0.35mm) constant amplitude or 5 G constant acceleration

Crossing frequency 60 Hz per IEC 68-2-6, test Fc

Environmental sealing protection IP 40 per IEC 529/DIN 40050

Body material Temperature resistant thermoplastic (UL 94V-O)

Contact material Brass, tin-plated

Patents US and Worldwide

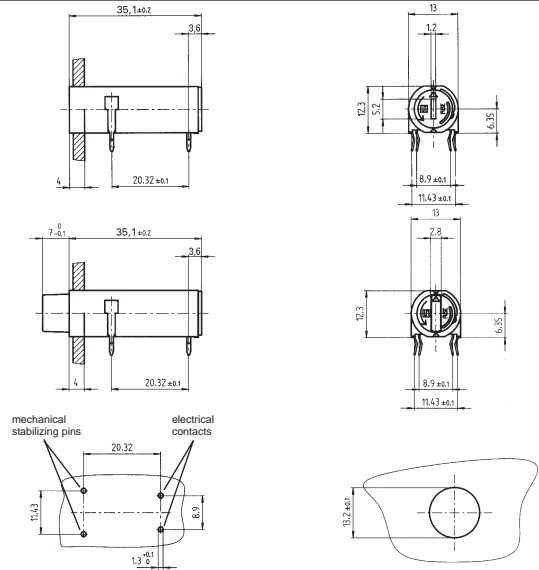
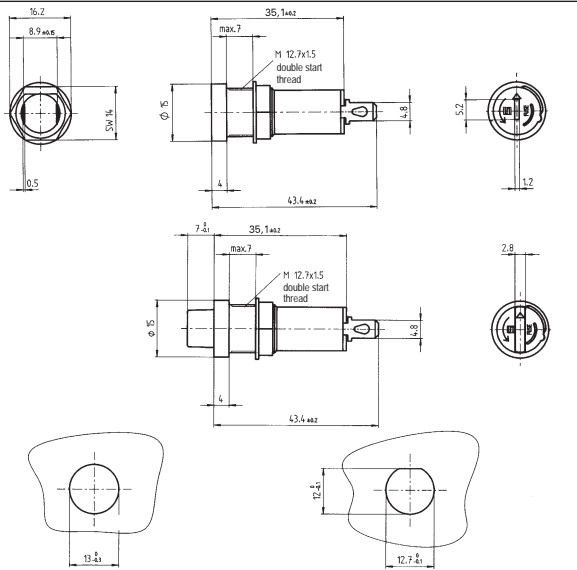
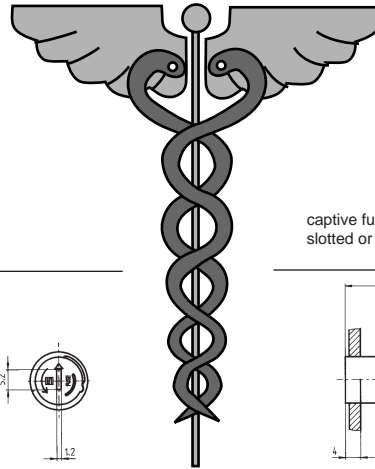

- panel mount for 5 x 20mm fuses
- captive bayonet fuse carrier – finger grip or slotted
- shockproof according to IEC 529 test probe; live parts are completely inaccessible to a probe measuring 1mm in diameter and 100mm in length (see page 3 for **more information about shock safety**)
- solder/quick-connect terminals .187 x .020" (4.8 x 0.5mm)
- anti-rotation protection (use "D" cutout)
- mounting hole: 12.7 mm (0.5")
- max. power dissipation 2.5 watts, according to IEC 127-6. For **additional values P_v in function of T_{amb}**, see page 5.

UL	recognition	(10A/250V)	File #E 39328
CSA	certification	(10A/250V)	File #LR 38456
VDE	approval	(10A/250V)	File #62305
SEMKO	approval	(10A/250V)	} File numbers on request
SEV	approval	(10A/250V)	
CS	certification	(10A/250V)	

- pcb mount for 5 x 20mm fuses:
- captive bayonet fuse carrier – finger grip or slotted
- shockproof according to IEC 529 test probe; live parts are completely inaccessible to a probe measuring 1mm in diameter and 100mm in length (see page 3 for **more information about shock safety**)
- body designed to protrude through panel opening
- stand-offs for flux-proofing and ease of cleaning
- solderability: 350°C/2 sec. (IEC 68-2-20 Test Ta, method 2)
- soldering resistance: 350°C/10 sec. (IEC 68-2-20 Test Tb, method 2)
- max. power dissipation 2.5 watts, according to IEC 127-6. For **additional values P_v in function of T_{amb}**, see page 5.

UL	recognition	(10A/250V)	File #E 39328
CSA	certification	(10A/250V)	File #LR 38456
VDE	approval	(10A/250V)	File #62305
SEMKO	approval	(10A/250V)	} File numbers on request
SEV	approval	(10A/250V)	
CS	certification	(10A/250V)	









Order Numbers (see page 102 for fuses)

FBS 0031.3911 Complete fuseholder with fuse carrier (finger grip)
FBS 0031.3901 Complete fuseholder with fuse carrier (slotted)

FBS 0031.3991 Complete fuseholder with fuse carrier (finger grip)
FBS 0031.3981 Complete fuseholder with fuse carrier (slotted)

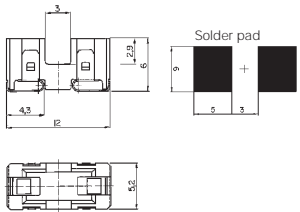
Accessories: See page 93 for square flange, anti-rotation washer, spare plastic or metal nut, face plates, insulation cover

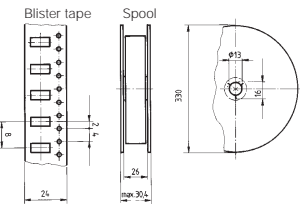
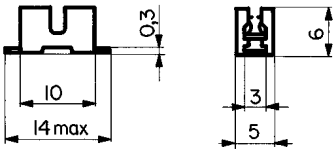
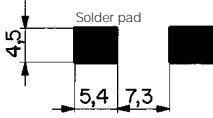
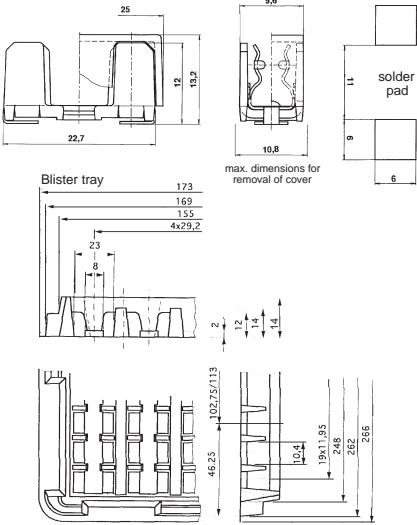





Board Mount Fuse Blocks – Surface Mount

 <p>OMH 125V accepts 7.4 x 3.1mm SMT fuse</p>	 <p>7090 accepts 7 x 2mm Melf SMT fuse</p>	 <p>OGN accepts 5 x 20mm fuse</p> <p><i>Blister tray package</i></p> 
  	 	
<ul style="list-style-type: none"> max. ambient temp. -40° C to +85° C vibration resistance: frequency range 10-500 Hz (1000Hz) amplitude, 0.75mm resp. accel. 100m/s²(10g), IEC 68-2-6, test Tc shock resistance: 981m/s²(100g), 11ms (IEC 68-2-27) climatic category: HPF (DIN 40040) reflow and vapor phase soldering power dissipation: 1.186 watts/ 136.4°C; 0.724 watts/94°C; 0.532 watts/75.9°C body: temp. resistant thermoplastic (UL 94V-O); contacts: tin plated copper alloy <p>3.5A max. recommended RMS current at 63V. 5A RMS current at 12V requires a minimum 10mm wide pcb trace.</p> <p>Standards: UL 512; CSA C22.2-39</p> <p>UL recognition (5A/125V) file #E39328 CSA certification (5A/125V) file #LR38456</p> <p>See pages 130-133 for the OMF 63V and 125V surface mount fuses</p> 	<ul style="list-style-type: none"> max. ambient temp. -55°C to +85°C suitable for reflow and vapor phase soldering power dissipation: max. 0.9 watts body: temperature resistant thermoplastic (UL 94V-O); contacts: bronze, tin plated <p><i>When used with fuses other than the Schurter Melf shown below, the suitability of these fuse blocks should be evaluated in the end use application.</i></p> <p>Standards: UL 512; CSA C22.2-39</p> <p>UL recognition (7A/125V) file #E41738 CSA certification (7A/125V) file # LR 23151-12</p> <p>See page 136 for the MELF 125V surface mount fuse</p> 	<ul style="list-style-type: none"> low profile fuse block with insulation walls, for 5 x 20mm fuse J-bend SMT terminals max. power dissipation 4 watts contact resistance: < .005 ohm at 20 mV (IEC 127-6) vibration resistance: frequency range 10-500 Hz, cross over frequency 60 Hz; < 60 Hz constant amplitude of 0.75mm, > 60 Hz constant acceleration 10g dielectric strength: >3kV, 50 Hz/1 min. max. ambient temp. -25°C to +85°C solderability: 235° C/2s (IEC 68-2-20/Ta); reflow and vapor phase soldering heat resistance: 350° C/5s (IEC 68-2-20/Tb) body: temperature resistant thermoplastic PETP (UL 94V-O); contacts: copper-alloy, tin-plated oxygen index rating: 33% for optional cover, see page 93 <p>Standards: UL 512, CSA C22.2-39, DIN/VDE 0820, IEC 257, EN 60257</p> <p>UL recognition (10A/250V) file #E39328 CSA certification (10A/250V) file #LR38456 VDE approval (10A/250V) file #70428 SEMKO approval (10A/250V) SEV approval (10A/250V)</p>

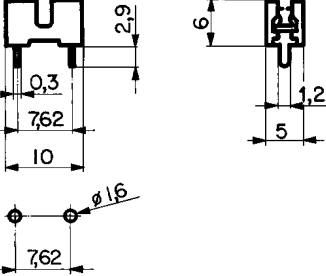
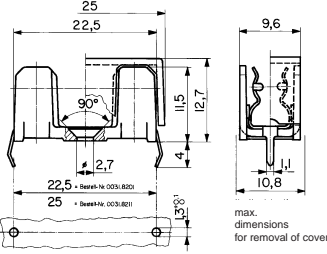
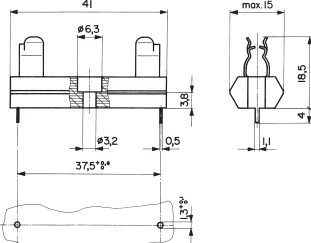
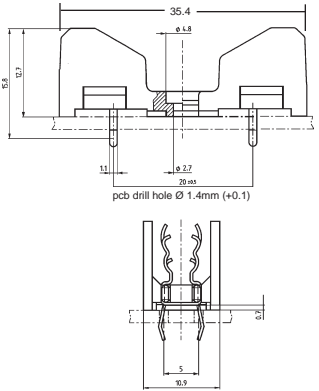

Order Numbers (see page 102 for fuses)

<p>0031.7701.11 packaged loose 0031.7701.22 750 pieces on tape & reel 0031.7701.23 1500 pieces on tape and reel</p>	<p>7090.9010.03 packaged loose (231786) 7090.9010.55 500 pieces on tape and reel (231786)</p>	<p>0031.8221 packaged loose 0031.8222 500 pieces – tray package for auto insertion</p>
--	---	--

Board Mount Fuse Blocks – Through-hole

 <p>7090 accepts 7 x 2mm Melf SMT fuse</p>	 <p>OGN accepts 5 x 20mm fuse</p>	 <p>OG accepts 1/4 x 1 1/4" fuse</p>	 <p>OGD accepts 5 x 20mm or 1/4 x 1 1/4" fuse</p>
			
<ul style="list-style-type: none"> max. ambient temp. T_{amb} -55°C to +85°C suitable for reflow and vapor phase soldering power dissipation max. 0.9 watts body: temperature resistant thermoplastic (UL 94V-O); contacts: bronze, tin plated <p>When used with fuses other than the Schurter Melf shown below, the suitability of these fuse blocks should be evaluated in the end use application.</p> <p>Standards: UL 512; CSA C22.2-39</p> <p>UL recognition (7A/125V) file #E41738 CSA certification (7A/125V) file # LR 23151-12</p> <p>See page 136 for the MELF 125V surface mount fuse </p>	<ul style="list-style-type: none"> low profile fuse block with insulation walls, for 5 x 20mm fuse "kicked" pcb terminals max. power dissipation 4 watts requires M 2.5 mounting screw (according to ISO 7046; not supplied) contact resistance: < .005 ohm at 20 mV (IEC 127-6) vibration resistance: frequency range 10-500 Hz, cross over frequency 60 Hz; < 60 Hz constant amplitude of 0.75mm, > 60 Hz constant acceleration 10g dielectric strength: >3kV, 50 Hz/1 min. Max. ambient temp. -25°C to +85°C solderability: 235°C/2s (IEC 68-2-20) soldering heat resistance: 350°C/5s (IEC 68-2-20/Tb) body: temp. resistant thermoplastic PETP (UL 94V-O) oxygen index rating: 33% contacts: brass, tin-plated for optional cover, see page 93 <p>Standards: UL 512, CSA C22.2-39, DIN/VDE 0820, IEC 257, EN 60257</p> <p>UL recognition (10A/250V) file #E39328 CSA certification (10A/250V) file #LR38456 VDE approval (10A/250V) file #70428 SEMKO approval (10A/250V) SEV approval (10A/250V)</p>	<ul style="list-style-type: none"> printed circuit board mountable for 1/4 x 1 1/4" fuse test voltage: 4 kV, 50 Hz/1min. -25°C to +85°C ambient temp. insulation resistance: > 10,000 meg-ohms at 500V DC contact resistance: < .004 ohm at 20 mV body: thermoset (UL 94V-O) max. power dissipation 4 watts contacts: German silver <p>Standards: UL 512, CSA C22.2-39, IEC 257, EN 60257</p> <p>UL recognition (16A/500V¹) file # E39328 CSA certification (10A/250V) file #LR38456 CS certification (10A/250V) ¹ Fuses according to 250V standards only</p>	<ul style="list-style-type: none"> international fuse block, accepts 1/4 x 1 1/4" fuse in upper or 5 x 20 mm fuse in lower portion impossible to have two fuses installed at the same time insulation walls reduce the risk of electric shock "kicked" pcb terminals clip ends prevent axial fuse movement max. power dissipation 4 watts contact resistance: < .005 ohm at 20 mV (IEC 127-6) vibration resistance: freq. range 10-500 Hz, cross over freq. 60 Hz; < 60 Hz constant amplitude of 0.75mm, > 60 Hz constant acceleration 10g Max. ambient temp. -25°C to +85°C solderability: 235°C/2s (IEC 68-2-20) soldering heat resistance: 350°C/10s (IEC 68-2-20/Tb) body: temperature resistant thermoplastic PBTP (UL 94V-0); contacts: brass, tin-plated U.S. and worldwide patents <p>Standards: UL 512, CSA C22.2-39, DIN/VDE0820, IEC257, EN60257</p> <p>UL recognition (16A/500V¹) file #E39328 CSA certification (16A/250V) file #LR38456 VDE approval (10A/250V) file #70428 SEMKO approval (10A/250V) SEV approval (10A/250V) ¹ Fuses according to 250V standards only</p>
Order Numbers (see page 102 for fuses)			
<p>7090.9020.03 packaged loose (231787)</p> <p>7090.9020.55 500 pieces on tape & reel (231787)</p>	<p>OGN 0031.8201 22.5 mm pin spacing</p> <p>OGN 0031.8211 25.0 mm pin spacing</p> <p>replacements for OG 031.8001/OGB 031.8101</p>	<p>OG 0031.8002</p>	<p>OGD 0031.8231</p>

Board Mount Fuse Blocks – Screw Mount

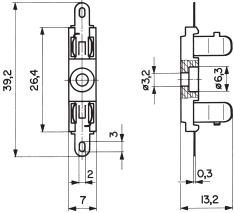
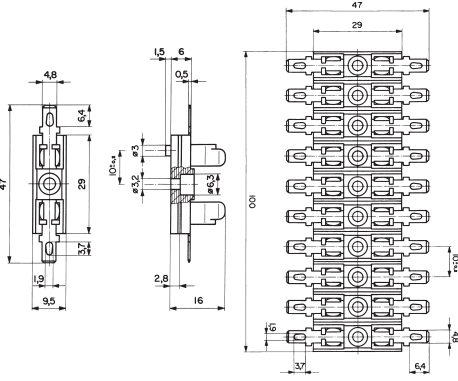
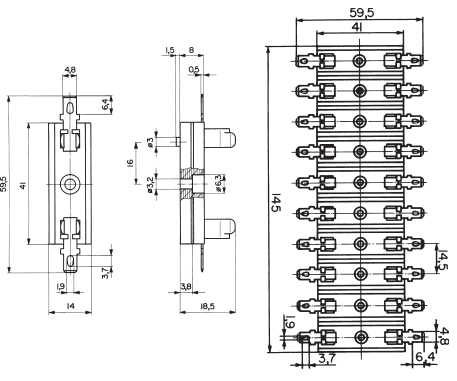
 <p>UHB accepts 5 x 20mm fuse</p>	 <p>UH accepts 5 x 20mm fuse</p>	 <p>RSH accepts 1/4 x 1 1/4" fuse</p>
		
<ul style="list-style-type: none"> • fuse block for 5 x 20mm fuse • solder terminals • test voltage: 50 Hz/1min.; > 3 kV between metal front plate and terminals • insulation resistance: > 10,000 meg-ohms at 500V DC • contact resistance: < .005 ohm at 20 mV • soldering heat resistance: max. 350°C/5sec. • body material: fiberglass-reinforced polycarbonate • contacts: brass, tin-plated • requires M3 mounting screw (not supplied) • power dissipation on request • for optional cover, see page 93 <p>Standards: UL 512, CSA C22.2-39, IEC 257</p> <p>UL recognition (6.3A/250V) file #E39328 CSA certification (6.3A/250V) file #LR38456</p>	<ul style="list-style-type: none"> • fuse block for 5 x 20mm fuse • single units or break-off strips of ten unit • solder/quick-connect terminals .187 x .020" (4.8 x 0.5mm) • test voltage: 3 kV, 50 Hz/1 min. • -25°C to +85°C ambient temp. • body: thermoset (UL 94V-O) • contacts: nickel silver • requires M3 mounting screw (not supplied) • power dissipation on request <p>Standards: UL 512, CSA C22.2-39, IEC 257</p> <p>UL recognition (10A/250V) file #E39328 CSA certification (10A/250V) file #LR38456 CS certification (10A/250V)</p>	<ul style="list-style-type: none"> • fuse block for 1/4 x 1 1/4" fuse • single units or break-off strips of ten units • solder/quick-connect terminals .187 x .020" (4.8 x 0.5mm) • test voltage: 3 kV, 50 Hz/1 min. • -25°C to +85°C ambient temp. • insulation resistance: > 10,000 meg-ohms at 500V DC • contact resistance: < .004 ohm at 20 mV • body: thermoset (UL 94V-O) • contacts: nickel silver • requires M3 mounting screw (not supplied) • max. power dissipation 4 watts <p>Standards: UL 512, CSA C22.2-39, IEC 257, EN 60257</p> <p>UL recognition (16A/500V¹⁾ file # E39328 CSA certification (10A/250V) file #LR38456 CS certification (10A/250V)</p> <p>¹⁾ Fuses according to 250V standards only</p>

Order Numbers (see page 102 for fuses)

UHB 0031.5101











UH 0031.5001 single unit

RSH 0031.6001 single unit

UH 0031.5010 strip of ten units

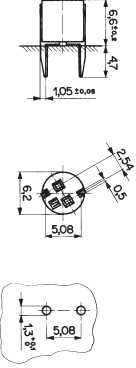
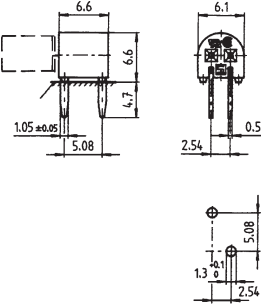
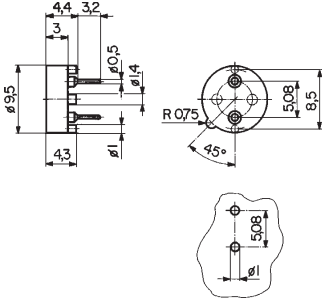
RSH 0031.6010 strip of ten units

Board Mount Holders for Microfuses

  <p>FMS 125V accepts 125V microfuse – vertical mount</p>	   <p>FMR 125V accepts 125V microfuse – horizontal mount</p>	 <p>FMS 250V accepts 250V microfuse</p>
		
<ul style="list-style-type: none"> through-hole mount fuseholder for vertical mounting of MSF 125V microfuse body: temp. resistant thermoplastic (UL 94V-O); contacts: brass, silver-plated <p>Standards: UL 512, CSA C22.2-39</p> <p>UL recognition (5A/125V) file #E39397 CSA certification (5A/125V) file #LR38456 CS certification (5A/125V)</p> <p>See page 139 for the MSF 125V microfuse</p> 	<ul style="list-style-type: none"> through-hole mount fuseholder for horizontal mounting of MSF 125V microfuse body: temp. resistant thermoplastic (UL 94V-O); contacts: brass, silver-plated <p>Standards: UL 512, CSA C22.2-39</p> <p>UL recognition (5A/125V) file #E39328 CSA certification (5A/125V) file #LR38456</p> <p>See page 139 for the MSF 125V microfuse</p> 	<ul style="list-style-type: none"> through-hole mount fuseholder accepts MSF, MST or MXT 250V microfuses rated 5A/250V body: temp. resistant thermoplastic (UL 94V-O); contacts: brass, tin-plated outside; 1 – 1.5µ gold inside <p>Standards: UL 512, CSA C22.2-39</p> <p>See pages 140-142 for the MSF/ MST / MXT 250V microfuses</p> 





Order Numbers (see page 102 for fuses)

FMS 0031.7501 for vertical mount microfuse

FMR 0031.7505 for horizontal mount microfuse

FMS 0031.7601



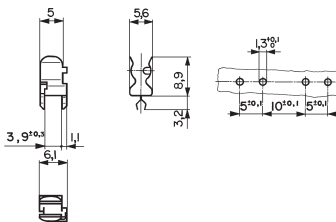
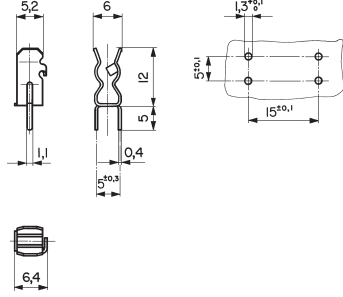
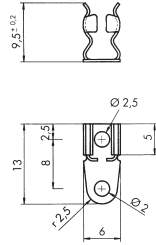
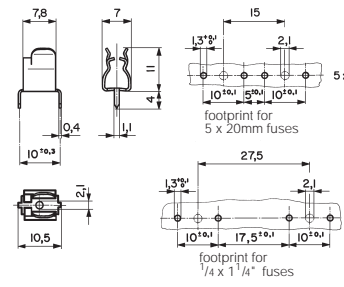

Board Mount Fuse Clips

 <p>OG accepts 5 x 20mm fuse</p>	 <p>OG accepts 5 x 20mm fuse</p>	 <p>7170 accepts 5 x 20mm fuse</p>	 <p>OG accepts 1/4 x 1 1/4" or 5 x 20mm fuses</p>
			
<ul style="list-style-type: none"> • fuse clip for 5 x 20 mm fuse • “kicked” terminals for optimum wave-soldering • current rating: 10A/250V • contacts: brass, tin-plated <p>Standards: UL 512 and IEC 257</p>	<ul style="list-style-type: none"> • fuse clip for 5 x 20 mm fuse • contacts: OG 0751.0052: bronze, tin-plated OG 0751.0062: brass, tin-plated • for optional cover, see page 93 <p>Standards: UL 512 and IEC 257</p> <p>UL recognition¹⁾ (6.3A/250V) file # E39328</p> <p>¹⁾ part number 0751.0052 only</p>	<ul style="list-style-type: none"> • fuse clip for 5 x 20mm fuse • screw-on pcb mount • solder terminals • contacts: bronze 	<ul style="list-style-type: none"> • international fuse clip, built to accept 1/4 x 1 1/4" or 5 x 20mm fuses • change in footprint needed for different fuse size • contacts: bronze, tin-plated <p>Standards: UL 512 and IEC 257</p> <p>UL recognition (10A/500V¹⁾ file # E39328</p> <p>¹⁾ Fuses according to 250V standards only</p>

Order Numbers (see page 102 for fuses)

<p>OG 0751.0110</p>	<p>OG 0751.0052 OG 0751.0062</p>	<p>7170.0430 (231014)</p>	<p>OG 0751.0056</p>
----------------------------	--	--------------------------------------	----------------------------



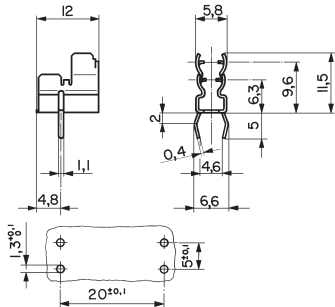
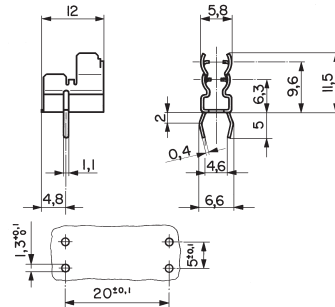
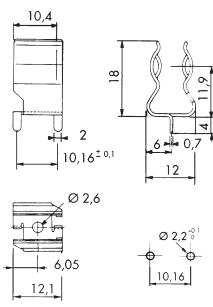
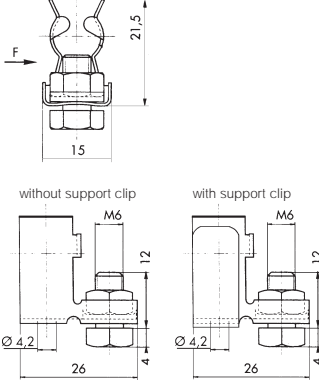







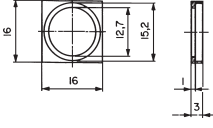

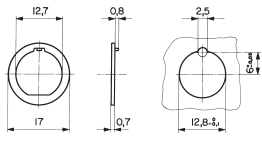
Board Mount Fuse Clips

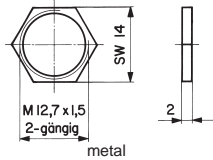

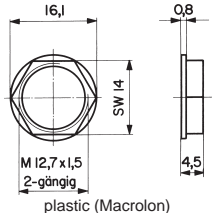

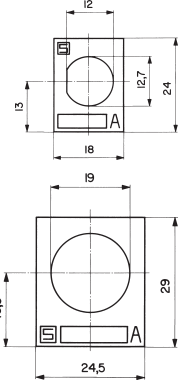

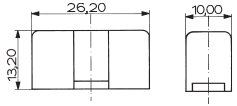
 <p>OG accepts 1/4 x 1 1/4" or 5 x 20mm fuses</p>	 <p>OG accepts 1/4 x 1 1/4" or 5 x 20mm fuses</p>	 <p>7170 accepts 10.3 x 38mm fuse</p>	 <p>7170 accepts 10.3 x 38mm fuse</p>
			
<ul style="list-style-type: none"> international fuse clip, accepts 1/4 x 1 1/4" fuse in upper or 5 x 20 mm fuse in lower portion impossible to have two fuses installed at the same time clip ends prevent axial movement of the fuse OG clip built in accordance with IEC 65, subclause 14.5.2, VDE 0860 IEC 257, UL 512 no change in footprint needed for different fuse size U.S. patented <p>Standards: UL 512 and IEC 257</p> <p>UL recognition (16A/500V¹⁾ file #E39328</p> <p>¹⁾ Fuses according to 250V standards only</p>	<ul style="list-style-type: none"> international fuse clip, accepts 1/4 x 1 1/4" fuse in upper or 5 x 20 mm fuse in lower portion impossible to have two fuses installed at the same time clip ends prevent axial movement of the fuse OG clip built in accordance with IEC 65, subclause 14.5.2, VDE 0860 IEC 257, UL 512 no change in footprint needed for different fuse size U.S. patented <p>Standards: UL 512 and IEC 257</p>	<ul style="list-style-type: none"> fuse clip accepts 10.3 x 38mm fuse for printed circuit board mounting hole for optional securing screw contacts: bronze, electroplated for 10.3 x 38mm quick-acting fuse see series A3BK, page 155 <p>UL recognition (20A) file # E41738 (Max. voltage depends on end use application)</p>	<ul style="list-style-type: none"> fuse clip accepts 10.3 x 38mm fuse screw-on pcb mount screw, plate and nut included support clip recommended, part number 7170.0130 (ordered separately) for 10.3 x 38mm quick-acting fuse see series A3BK, page 155

Order Numbers (see page 102 for fuses)

<p>OG 0751.0099 fuse clip, tin-plated bronze</p>	<p>OG 0751.0100 fuse clip, tin-plated brass</p>	<p>7170.0470 (231660)</p>	<p>7170.0520 (23634)</p>
---	--	--------------------------------------	-------------------------------------

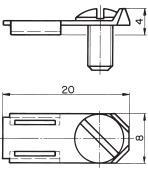
Accessories For Fuseholders / Fuse Blocks / Fuse Clips

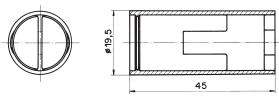
 <p>Square flange</p> <p>Can be used with all fuseholders with a 0.5" mounting hole</p> 	 <p>Anti-rotation washer</p> <p>For securing fuseholders with a 0.5" mounting hole without having to punch a complicated "D" cut-out</p> 	 <p>Metal nut made from nickel-plated brass. Thread: M 12.7 x 1.5 double pitch</p>   <p>Plastic nut, fiberglass reinforced polycarbonate. Thread: M12.7 x 1.5, double pitch. <i>Fuseholders may be supplied with clear or black plastic nut. Conversion to black nut in progress.</i></p> 	 <p>Fuseholder faceplate with self adhesive backing for fuseholders with a 0.5" mounting hole</p>   <p>Fuseholder faceplate with self adhesive backing for fuseholders with a 5/8" or 3/4" mounting hole</p> 	 <p>Cover for fuse block UHB 0031.5101 and fuse clips OG 0751.0052/0062</p> <p>OGH 0853.9561: Macrolon (UL94 V-O), max. 1.6 Watts power dissipation</p> <p>OGH 0853.9562: Vitrex (UL94 V-O), max. 3.15 Watts power dissipation</p>
Order Numbers				
QF 0853.0066	VSI 0696.0033	0098.0026 Metal 0098.0093 Plastic	0880.0001 0.5" 0880.0002 5/8" or 3/4"	shown above with photos

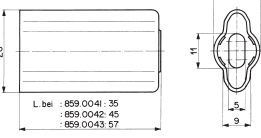
 <p>Cover for fuse blocks OGN 0031.8201/8211/8221</p> <p>Macrolon (UL 94V-O), max. 1.6 Watts power dissipation</p>	 <p>Screw-adapter for quick-connect terminals .250 x .032", straight (6.3 x 0.8mm)</p> 	 <p>Insulation boot for fuseholders FEU and FBS panel mount. Made of flexible plastic (UL 94V-O)</p>	 <p>Insulation boot for fuseholders FIZ/FUL. Made from UL recognized component plastic (UL file #E41871)</p> 	 <p>Insulation boot for fuseholders FEU. Made from UL recognized component plastic (UL file #E41871)</p> 
Order Numbers				
OGH 0853.0551	0750.0141	0859.0081	0859.0046	0859.0041 for FEU 031.1653 0859.0042 for FEU 031.1673 0859.0042 for FEU 031.1681 0859.0043 for FEU 031.1694