

### 1. Wiring for 4783

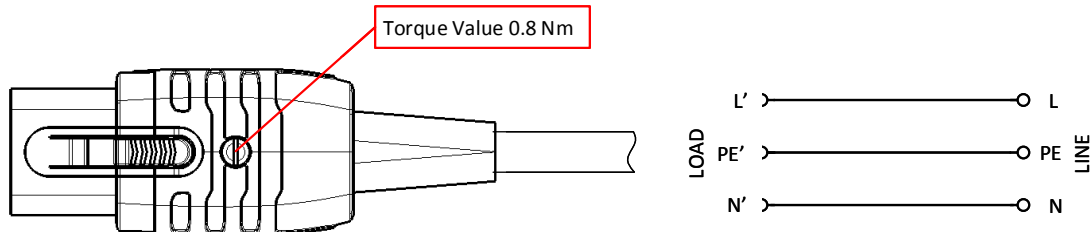
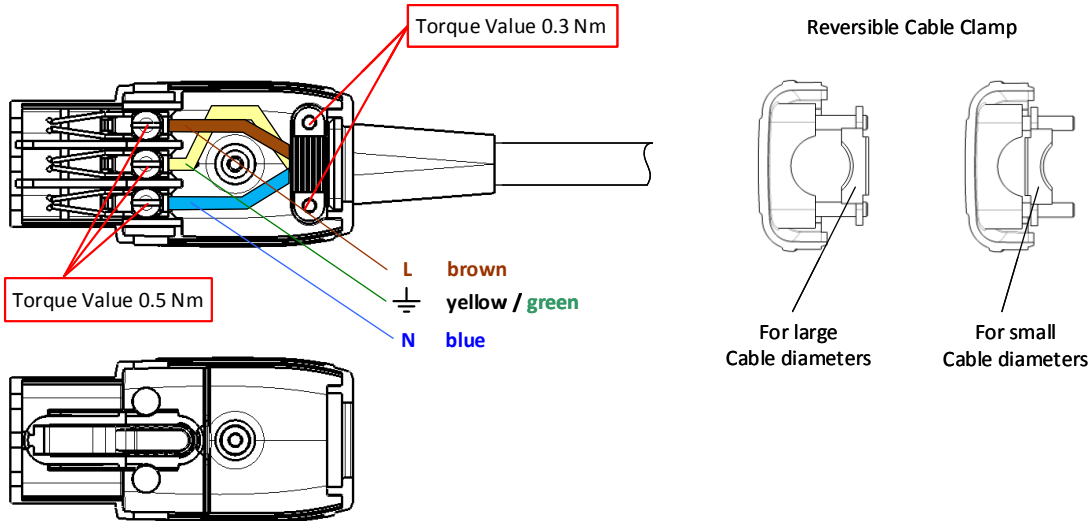
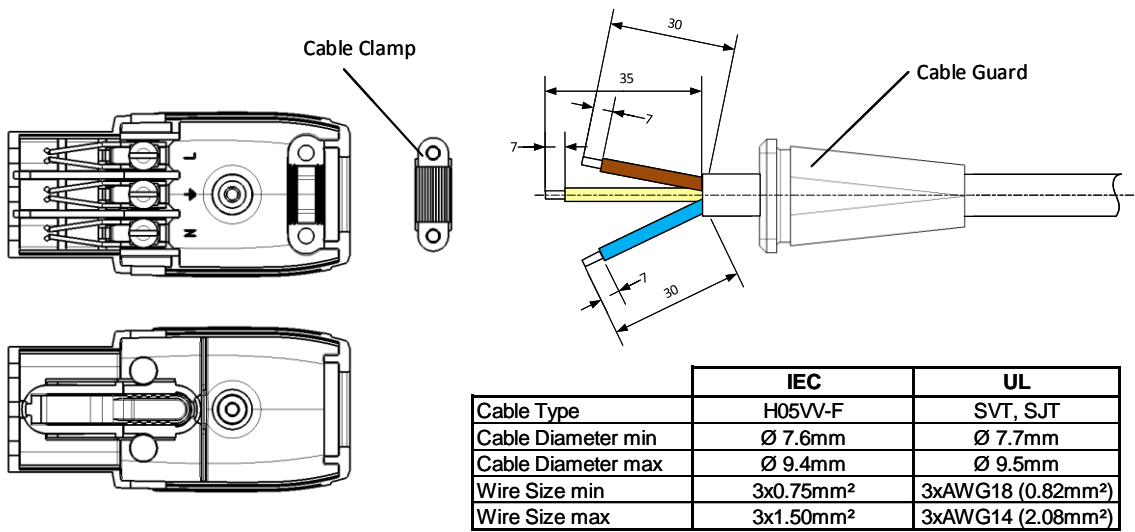

## 2. Assembly Instruction

### Disconnect power before wiring!

Keep removed piece parts at a safe place to have them ready for reassembling.

1. Loosen cover screw and remove cover.
2. Loosen cable clamp screws and remove cable guard.
3. Insert cord into cable guard.
4. Remove outer jacket on cord 35 mm. Make sure not to hurt insulation of single conductors.
5. Reduce the length of the "neutral" and "line" wire to 30 mm.
6. Strip the insulation from the wires at a length of 7 mm.
7. Loosen terminal screws but do not remove screws.
8. Connect green or green/yellow (ground) wire to center clamp marked with ground symbol.
9. Connect blue (white or light grey) wire to clamp marked „N“ (neutral).
10. Connect brown (black / "hot") wire to clamp marked „L“ (line).
11. Tighten all wire clamp screws with a torque of 0.5 Nm.
12. Insert shoulder of cable guard into cutout of base unit.
13. Assemble cable clamp over cut-off end of outer jacket of the cord and tighten cable clamp screws with a torque of 0.3 Nm. (Turn the cable clamp for small cable diameters)
14. Assemble cover unit and tighten cover screw with a torque of 0.8 Nm.

### Warning:

**Failure to wire as instructed may cause personal injury or damage to device or equipment.  
To be installed or checked by an qualified person only.  
For factory assembly only.**

Operation Manual					Wiring for 4783	
owner	creation date	release date	released by	change order no	rev	page
huberth	29.07.2019	29.07.2019	huberth	2018100	B	2 of 2
						D10-024-540