



»» Features

- 20A miniature PCB Power Relay.
- 1 form A contact configuration with quick terminal type.
- 5KV dielectric strength, 10K surge voltage between coils to contact.
- Ideal for high rating Home Appliances of heating element control.
- RoHS Compliant.

»» Type List

◆ Standard Type

Terminal style	Contact form	UL Insulation system approval	Designation (provided with)
			Flux tight
P (PCB terminal)	1A (SPNO)	-----	302P-1AB-C
		-----	302P-1AH-C
		-----	302P-1AC-C
		F	302P-1AB-F-C
		F	302P-1AH-F-C
		F	302P-1AC-F-C
WP (PCB terminal & Quick terminal)	1A (SPNO)	-----	302WP-1AB-C
		-----	302WP-1AH-C
		-----	302WP-1AC-C
		F	302WP-1AB-F-C
		F	302WP-1AH-F-C
		F	302WP-1AC-F-C
WP1 PCB terminals (2 coil terminals & 1 NO terminal) & Quick terminals	1A (SPNO)	-----	302WP1-1AB-C
		-----	302WP1-1AH-C
		-----	302WP1-1AC-C
		F	302WP1-1AB-F-C
		F	302WP1-1AH-F-C
		F	302WP1-1AC-F-C
WP2 PCB terminals (2 coil terminals & 2 stationary support terminals) & Quick terminals	1A (SPNO)	-----	302WP2-1AB-C
		-----	302WP2-1AH-C
		-----	302WP2-1AC-C
		F	302WP2-1AB-F-C
		F	302WP2-1AH-F-C
		F	302WP2-1AC-F-C

◆ High Sensitivity Type

P (PCB terminal)	1A (SPNO)	-----	302NP-1AB-C
		-----	302NP-1AH-C
		-----	302NP-1AC-C
		F	302NP-1AB-F-C
		F	302NP-1AH-F-C
		F	302NP-1AC-F-C
WP (PCB terminal & Quick terminal)	1A (SPNO)	-----	302NWP-1AB-C
		-----	302NWP-1AH-C
		-----	302NWP-1AC-C
		F	302NWP-1AB-F-C
		F	302NWP-1AH-F-C
		F	302NWP-1AC-F-C
WP1 PCB terminals (2 coil terminals & 1 NO terminal) & Quick terminals	1A (SPNO)	-----	302NWP1-1AB-C
		-----	302NWP1-1AH-C
		-----	302NWP1-1AC-C
		F	302NWP1-1AB-F-C
		F	302NWP1-1AH-F-C
		F	302NWP1-1AC-F-C
WP2 PCB terminals (2 coil terminals & 2 stationary support terminals) & Quick terminals	1A (SPNO)	-----	302NWP2-1AB-C
		-----	302NWP2-1AH-C
		-----	302NWP2-1AC-C
		F	302NWP2-1AB-F-C
		F	302NWP2-1AH-F-C
		F	302NWP2-1AC-F-C

»» Ordering Information

302 WP - 1A H - - C
 1 2 3 4 5 6 7 8 9

- | | |
|--|---|
| 1. 302 -- Basic series designation | 5. B -- Contact material AgCdO |
| 2. Blank -- Standard type | C -- Contact material AgNi |
| N -- High sensitivity type | H -- Contact material AgSnO |
| 3. P -- PCB terminals | 6. Blank -- Standard type |
| WP -- PCB terminals and Quick terminals | F -- Class F |
| WP1 -- PCB terminals (2 coil terminals and 1 NO terminal) and Quick terminals | 7. C -- Flux tight |
| WP2 -- PCB terminals (2 coil terminals and 2 stationary support terminals) and Quick terminals | 8. Blank -- Standard type |
| 4. 1A -- Single pole normally open | E1 -- Comply with IEC 60335-1 |
| | 9. <input type="checkbox"/> -- Coil voltage (please refer to the coil rating data for the availability) |

»» Contact Rating

Resistive load	17A 240VAC
Max. switching current	20A
Max. switching voltage	277VAC
Max. switching capacity	4080VA

»» Coil Rating (DC)

◆Standard Type

Rated voltage (V)	Rated current ±10 % at 23°C (mA)	Coil resistance ±10 % at 23°C (Ω)	Max. continuous voltage at 85°C	Pick up voltage(Max.) at 23°C	Drop out voltage(Min.) at 23°C	Power consumption at rated voltage
3	176	17	160 % of rated voltage	75 % of rated voltage	10 % of rated voltage	approx. 0.53W
5	106	47				
6	88	68				
9	59	153				
12	44	272				
15	35	425				
18	29	611				
21	25	832				
24	22	1,087				
36	15	2,445				
48	11	4,347				
60	8.8	6,792				
100	5.3	18,868				
110	4.8	22,830				

◆High Sensitivity Type

Rated voltage (V)	Rated current ±10 % at 23°C (mA)	Coil resistance ±10 % at 23°C (Ω)	Max. continuous voltage at 85°C	Pick up voltage(Max.) at 23°C	Drop out voltage(Min.) at 23°C	Power consumption at rated voltage
3	133	22.5	160 % of rated voltage	75 % of rated voltage	10 % of rated voltage	approx. 0.4W
5	80	62.5				
6	67	90				
9	44	202.5				
12	33	360				
15	27	563				
18	22	810				
21	19	1,103				
24	17	1,440				

◆ High Sensitivity Type

Rated voltage (V)	Rated current ±10 % at 23°C (mA)	Coil resistance ±10 % at 23°C (Ω)	Max. continuous voltage at 85°C	Pick up voltage(Max.) at 23°C	Drop out voltage(Min.) at 23°C	Power consumption at rated voltage
36	11	3,240	160 % of rated voltage	75 % of rated voltage	10 % of rated voltage	approx. 0.4W
48	8.3	5,760				
60	6.7	9,000				
100	4.0	25,000				
110	3.6	30,250				

»» Specification

Contact material	AgSnO / AgNi / AgCdO alloy	
Contact resistance ⁽¹⁾	50mΩ Max. (at 1A/6VDC by 4-wire resistance measurement)	
Operate time ⁽¹⁾	20ms Max.	
Release time ⁽¹⁾	10ms Max.	
Vibration resistance	Operating extremes	10~55Hz , amplitude 1.5 mm
	Damage limits	10~55Hz , amplitude 1.5 mm
Shock resistance	Operating extremes	10G
	Damage limits	100G
Life expectancy	Mechanical	10,000,000 ops. (frequency 18,000 ops./hr)
	Electrical	100,000 ops. (frequency 1,800 ops./hr)
Operating ambient temperature	-40~+85°C (no freezing)	
Weight	Approx. 17 g	

Note : (1) Initial value. Operate and release time excluding contact bounce.

(2) Unless otherwise specified, all tests are under room temperature and humidity.

(3) Consider the heat of PCB is necessary, please check the actual condition of PCB.

(4) Applying no diode to this relay. The life expectancy will be lower when a diode is used. To use a varistor (ZNR) could absorb the coil surge of relay that is recommended.

(5) Do not use the relay exceeding the coil rating, contact rating and life expectancy, or this may cause the risk of overheating.

(6) To assure optimum performance, avoid the relay from dropping, hitting, or other unnecessary shocks.

(7) Use suitable harnesses and bus bars according to the current as below :

17A type : Min. 3.0 mm²

(8) Usage, transport and storage conditions

- 1. Temperature: -40~+85°C
- 2. Humidity: 5 to 85% R.H.
- 3. Pressure: 86 to 106 kPa
- Furthermore, the humidity range varies with the temperature. So, use relays within the range indicated in the graph below.

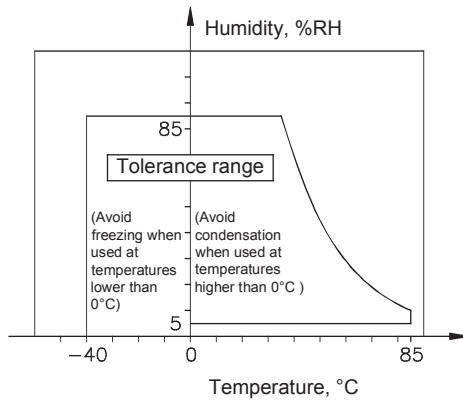

(9) Please contact Song Chuan for the detailed information.

»» Insulation Data

Insulation resistance ⁽¹⁾	1000 MΩ Min. (DC 500V)
Dielectric strength ⁽¹⁾	Between open contact : AC 1000V , 50/60Hz 1 min.
	Between contact and coil : AC 5000V, 50/60Hz 1 min.
Insulation of IEC 61810-1	
Clearance / creepage distances	Between coil to contact : Reinforce, ≥ 6.0mm / ≥ 8.0mm
	Between open contact : Functional
Rated insulation voltage	250V
Rated impulse withstand voltage	4000V
Pollution degree	3
Rated voltage	230 / 400V
Overtoltage category	II

Note : (1) Initial value.

»» Safety Approval

Certified	UL / CUL	TUV
File No.	E88991	R 50025929

»» Safety Approval Rating

UL / CUL		TUV
B · BA / C · CA	H · HA	
20A 277VAC	20A 277VAC	17A 250VAC
1 1/2HP 250VAC	1 1/2HP 250VAC	20A 250VAC
1HP 125VAC	8A 120VAC Tungsten	12A 250VAC cos φ 0.4

»» Outline Dimensions

◆ 302P

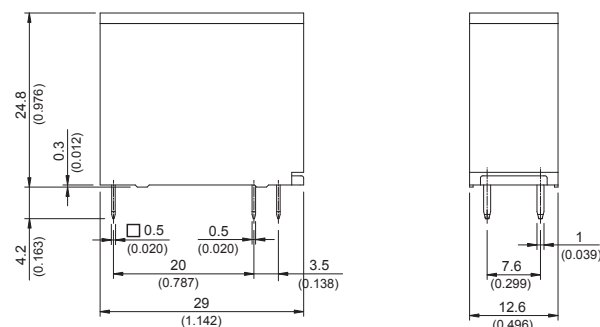

302

◆ 302WP

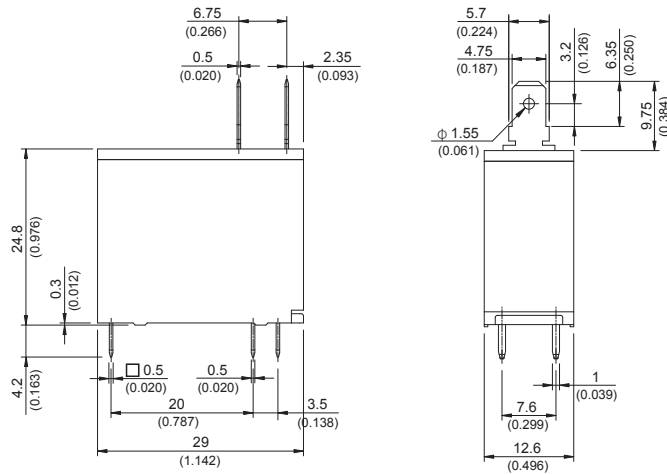

◆ 302WP1

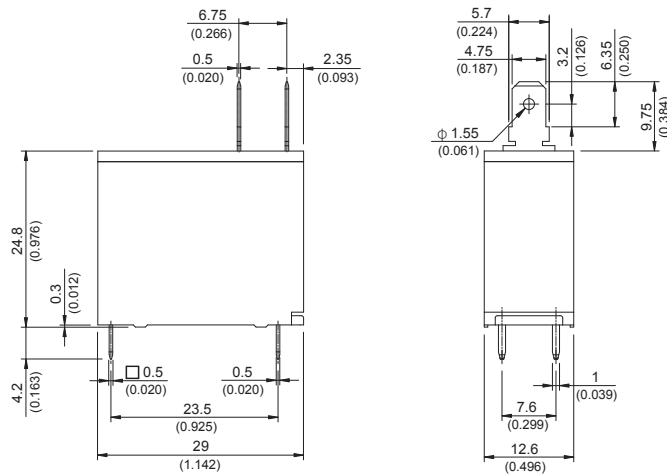

◆ 302WP2

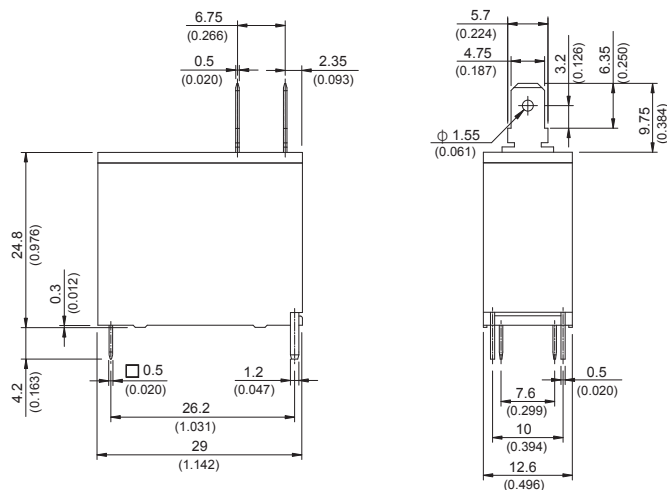

TOLERANCE:
 LESS THAN: 1(0.039) ±0.1(0.004)
 5(0.197) ±0.3(0.012)
 20(0.787) ±0.5(0.020)
 MORE THAN: 20(0.787) ±1(0.039)

»» Wiring Diagram
 BOTTOM VIEW



»» PC Board Layout BOTTOM VIEW

◆ 302P, 302WP

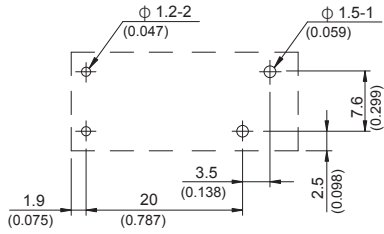

◆ 302WP1

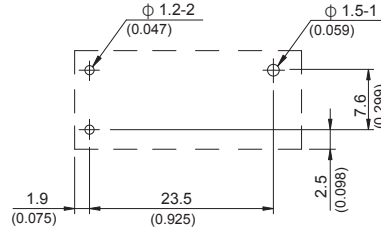

◆ 302WP2

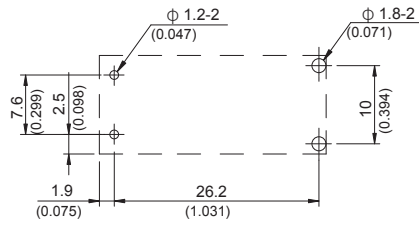

»» Engineering Data

