

PROTECTION PRODUCTS - MicroClamp™

Description

The μ Clamp™ series of TVS arrays are designed to protect sensitive electronics from damage or latch-up due to ESD, lightning, and other voltage-induced transient events. Each device will protect up to four lines operating at **3.3 volts**.

The μ Clamp™3324P is a solid-state device designed specifically for transient suppression. It is constructed using Semtech's proprietary EPD process technology. The EPD process provides low standoff voltages with significant reductions in leakage currents and capacitance over traditional pn junction processes. They offer desirable characteristics for board level protection including fast response time, low clamping voltage and no device degradation.

The μ Clamp3324P may be used to meet the immunity requirements of IEC 61000-4-2, level 4 (± 15 kV air, ± 8 kV contact discharge). The "flow-thru" design of the device results in enhanced ESD performance due to reduced board trace inductance. The result is lower clamping voltage and a higher level of protection when compared to conventional TVS devices.

The μ Clamp3324P is in an 8-pin, RoHs compliant, SLP2116P8 package. It measures 2.1 x 1.6 x 0.58mm. The leads are spaced at a pitch of 0.5mm and are finished with lead-free NiPd. The small package makes it ideal for use in portable electronics such as cell phones, digital still cameras, and notebook computers.

Circuit Diagram

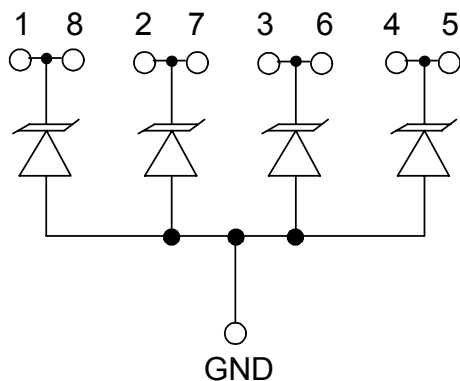

Device Schematic

Features

- ◆ Transient protection for data lines to **IEC 61000-4-2 (ESD) ± 15 kV (air), ± 8 kV (contact)**
IEC 61000-4-4 (EFT) 40A (tp = 5/50ns)
- ◆ Small package for use in portable electronics
- ◆ Protects four I/O
- ◆ Working voltage: 3.3V
- ◆ Flow thru design for easy layout
- ◆ Low leakage current
- ◆ Low operating and clamping voltages
- ◆ Solid-state silicon-avalanche technology

Mechanical Characteristics

- ◆ SLP2116P8 package
- ◆ RoHs Compliant
- ◆ Nominal Dimensions: 2.1 x 1.6 x 0.58 mm
- ◆ Lead Pitch: 0.5mm
- ◆ Lead Finish: NiPd
- ◆ Marking : Orientation Mark and Marking Code
- ◆ Packaging : Tape and Reel per EIA 481

Applications

- ◆ Cellular Handsets & Accessories
- ◆ Personal Digital Assistants (PDA's)
- ◆ Notebooks & Handhelds
- ◆ Portable Instrumentation
- ◆ Digital Cameras
- ◆ Peripherals
- ◆ MP3 Players

Package

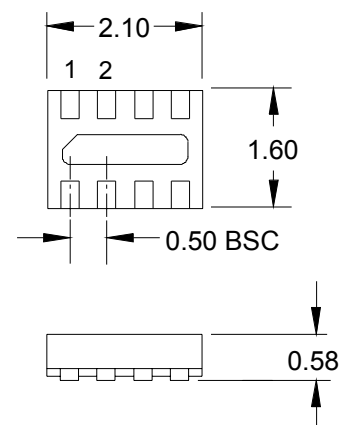

8 Pin SLP package (Bottom Side View)
2.1 x 1.6 x 0.58mm (Nominal)

PROTECTION PRODUCTS

Absolute Maximum Rating

Rating	Symbol	Value	Units
Peak Pulse Power (tp = 8/20μs)	P_{pk}	40	Watts
Maximum Peak Pulse Current (tp = 8/20μs)	I_{pp}	5	Amps
ESD per IEC 61000-4-2 (Air) ESD per IEC 61000-4-2 (Contact)	V_{pp}	+/- 20 +/- 15	kV
Operating Temperature	T_J	-55 to +125	°C
Storage Temperature	T_{STG}	-55 to +150	°C

Electrical Characteristics (T=25°C)

Parameter	Symbol	Conditions	Minimum	Typical	Maximum	Units
Reverse Stand-Off Voltage	V_{RWM}				3.3	V
Punch-Through Voltage	V_{PT}	$I_{PT} = 2\mu A$	3.5			V
Snap-Back Voltage	V_{SB}	$I_{SB} = 50mA$	2.8			V
Reverse Leakage Current	I_R	$V_{RWM} = 3.3V$		0.05	0.5	μA
Clamping Voltage	V_C	$I_{pp} = 1A$, tp = 8/20μs Any I/O to Gnd			5.5	V
Clamping Voltage	V_C	$I_{pp} = 5A$, tp = 8/20μs Any I/O to Gnd			8.0	V
Reverse Clamping Voltage	V_{CR}	$I_{pp} = 1A$, tp = 8/20μs Any I/O to Gnd			2.4	V
Junction Capacitance	C_J	I/O pin to Gnd $V_R = 0V$, f = 1MHz		25	30	pF
		I/O pin to Gnd $V_R = 3.3V$, f = 1MHz		14		pF

PROTECTION PRODUCTS

Typical Characteristics

Non-Repetitive Peak Pulse Power vs. Pulse Time

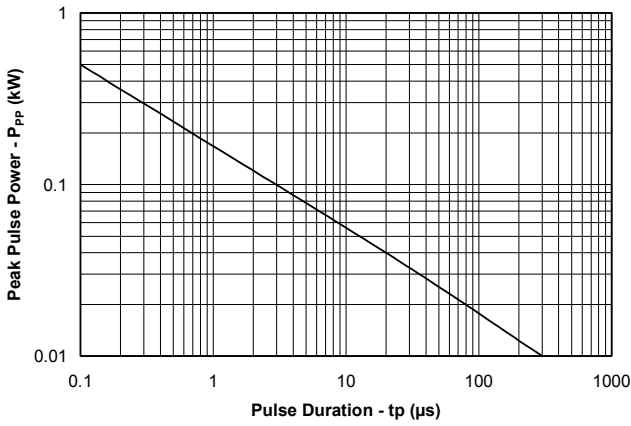

Power Derating Curve

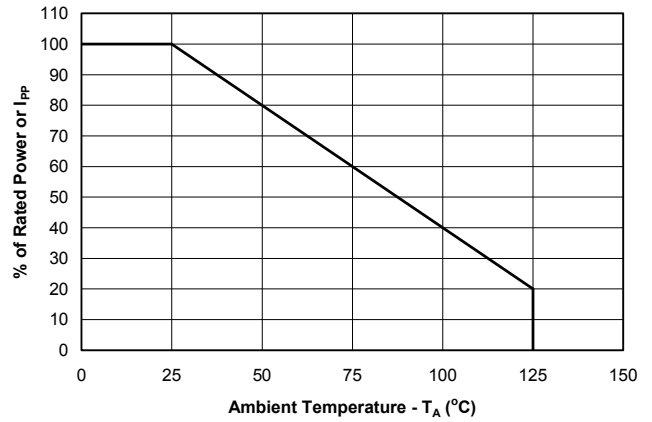

Clamping Voltage vs. Peak Pulse Current

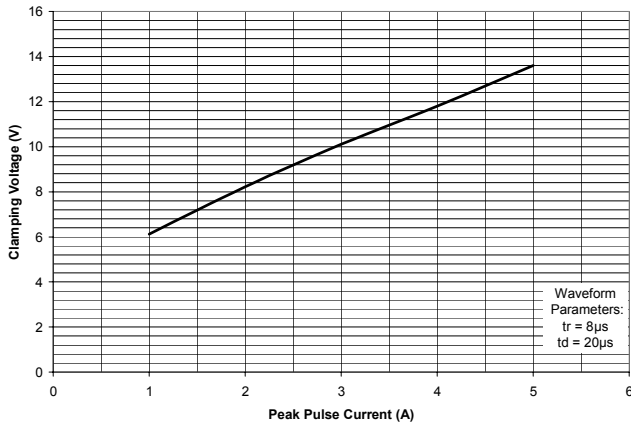

Forward Voltage vs. Forward Current

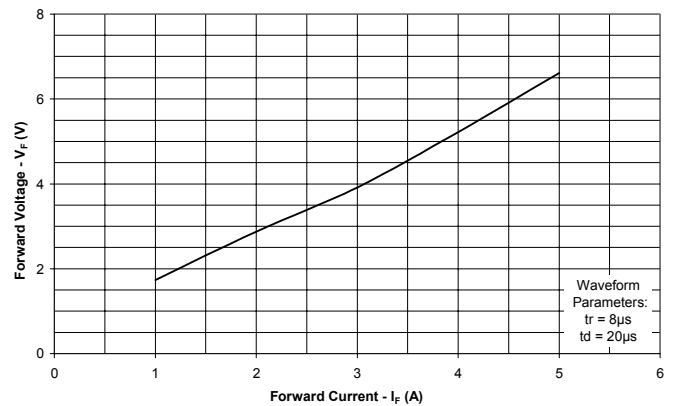

Junction Capacitance vs. Reverse Voltage

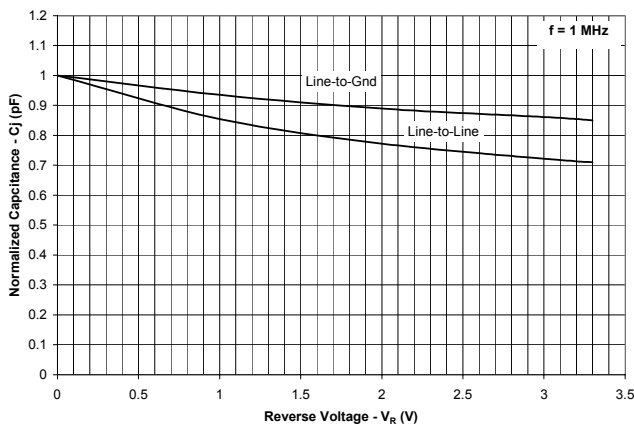

ESD Clamping (8kV Contact per IEC 61000-4-2)

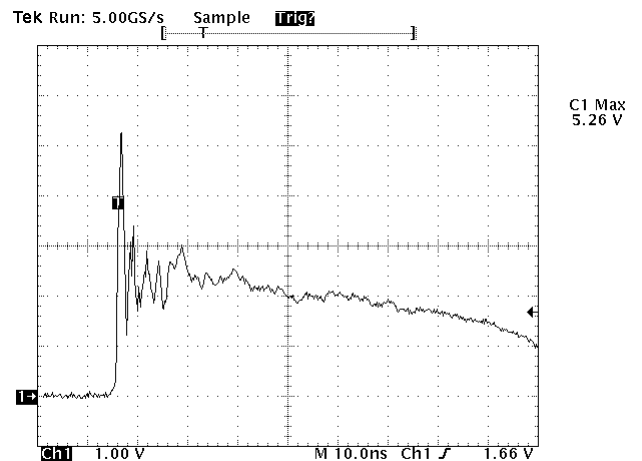

PROTECTION PRODUCTS

Applications Information

Device Connection Options

The μ Clamp3324P is designed to protect four lines. It will present a high impedance to the protected line up to 3.3 volts. It will “turn on” when the line voltage exceeds 3.5 volts. The device is unidirectional and may be used on lines where the signal polarity is above ground.

Flow Thru Layout

The μ Clamp3324P is designed for ease of PCB layout by allowing the traces to enter one side of the device and exit the other side. Figure 2 shows the recommended way to design the PCB board traces in order to use the flow through layout. The solid line represents the PCB trace. Note that the PCB traces enter at the input pin and exit from the opposite pin. (pin 1 to pin 8, pin 2 to pin 9, pin 3 to pin 6, pin 4 to pin 5). For example, line 1 enters at pin 1 and exits at Pin 8. The bottom tab is connected to ground. This connection should be made directly to a ground plane on the board for best results. The path length is kept as short as possible to minimize parasitic inductance.

EPD TVS Characteristics

These devices are constructed using Semtech’s proprietary EPD technology. The structure of the EPD TVS is vastly different from the traditional pn-junction devices. At voltages below 5V, high leakage current and junction capacitance render conventional avalanche technology impractical for most applications. However, by utilizing the EPD technology, these devices can effectively operate at 3.3V while maintaining excellent electrical characteristics.

The EPD TVS employs a complex npnp structure in contrast to the pn structure normally found in traditional silicon-avalanche TVS diodes. The EPD mechanism is achieved by engineering the center region of the device such that the reverse biased junction does not avalanche, but will “punch-through” to a conducting state. This structure results in a device with superior DC electrical parameters at low voltages while maintaining the capability to absorb high transient currents.

Figure 1 - Circuit Diagram

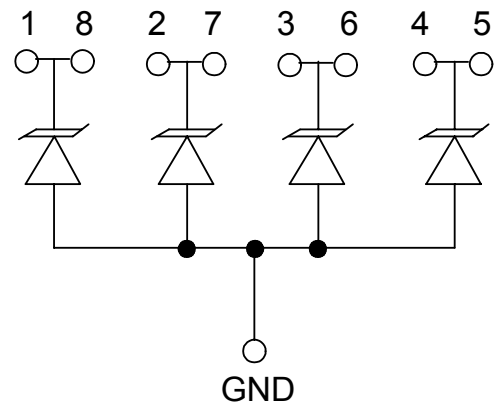

Figure 2 - Layout Example

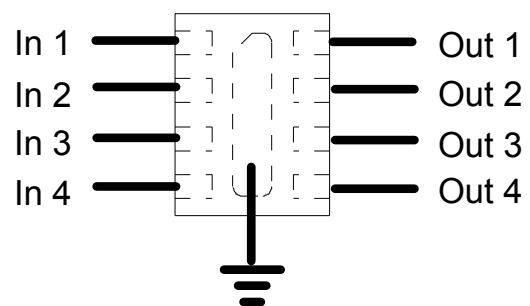
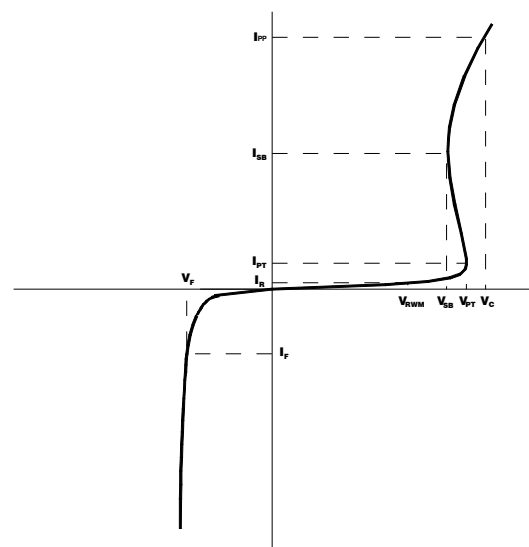
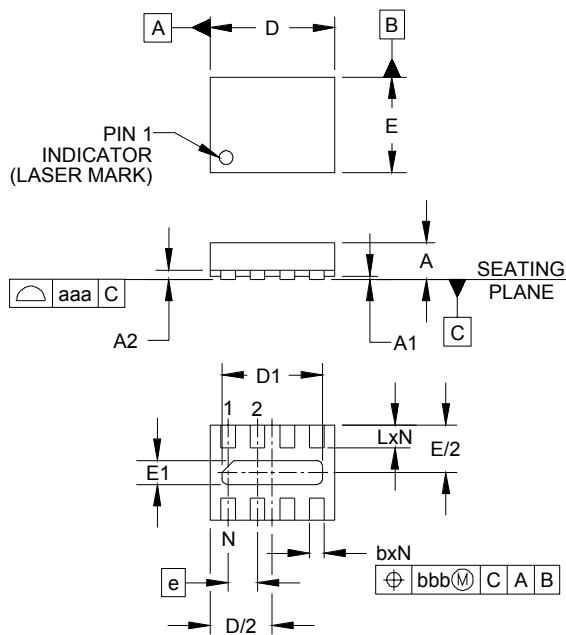

Figure 3 - EPD TVS IV Characteristic Curve



PROTECTION PRODUCTS

Outline Drawing - SLP2116P8



DIM	INCHES			MILLIMETERS		
	MIN	NOM	MAX	MIN	NOM	MAX
A	.020	.023	.026	0.50	0.58	0.65
A1	-	.001	.002	0.00	.003	0.05
A2	-	(.006)		(0.15)		
b	.007	.010	.012	0.20	0.25	0.30
D	.079	.083	.087	2.00	2.10	2.20
D1	.061	.067	.071	1.55	1.70	1.80
E	.059	.063	.067	1.50	1.60	1.70
E1	.010	.016	.020	0.25	0.40	0.50
e	.020 BSC		0.50 BSC			
L	.011	.013	.015	0.28	0.33	0.38
N	6			6		
aaa	.003			0.08		
bbb	.004			0.10		

NOTES:

1. CONTROLLING DIMENSIONS ARE IN MILLIMETERS (ANGLES IN DEGREES).
2. COPLANARITY APPLIES TO THE EXPOSED PAD AS WELL AS THE TERMINALS.

Land Pattern - SLP2116P8

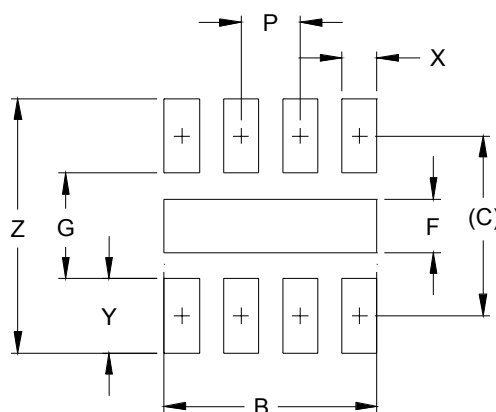

DIM	DIMENSIONS	
	INCHES	MILLIMETERS
B	.071	1.80
C	.060	1.52
F	.018	0.45
G	.035	0.89
P	.020	0.50
X	.012	0.30
Y	.025	0.63
Z	.085	2.15

NOTES:

1. THIS LAND PATTERN IS FOR REFERENCE PURPOSES ONLY. CONSULT YOUR MANUFACTURING GROUP TO ENSURE YOUR COMPANY'S MANUFACTURING GUIDELINES ARE MET.

PROTECTION PRODUCTS

Marking

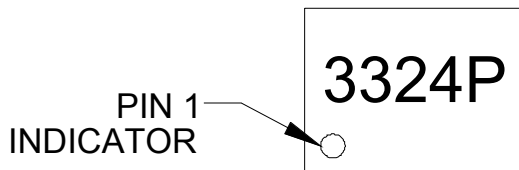

Ordering Information

Part Number	Working Voltage	Device Marking	Qty per Reel	Reel Size
uClamp3324P.TCT	3.3V	3324P	3,000	7 Inch

MicroClamp, uClamp and μ Clamp are marks of Semtech Corporation

Tape and Reel Specification

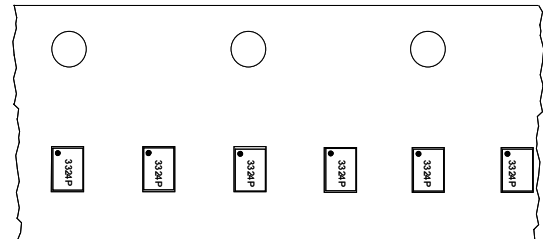
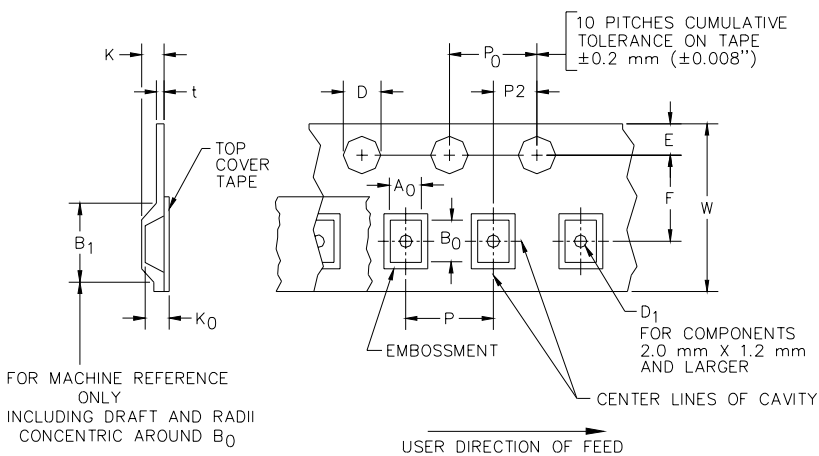

Device Orientation in Tape

A0	B0	K0
1.96 +/-0.05 mm	2.31 +/-0.05 mm	0.74 +/-0.05 mm

Tape Width	B, (Max)	D	D1	E	F	K (MAX)	P	P0	P2	T(MAX)	W
8 mm	4.2 mm (.165)	1.5 + 0.1 mm - 0.0 mm (0.59 +.005 -.000)	0.8 mm ± 0.05 (.031)	1.750 \pm 0.10 mm (.069 \pm .004)	3.5 \pm 0.05 mm (.138 \pm .002)	2.4 mm (.094)	4.0 \pm 0.1 mm (.157 \pm .00-4)	4.0 \pm 0.1 mm (.157 \pm .00-4)	2.0 \pm 0.05 mm (.079 \pm .002)	0.4 mm (.016)	8.0 mm + 0.3 mm - 0.1 mm (.312 \pm .012)

Contact Information for Semtech International AG

Taiwan Branch	Tel: 886-2-2748-3380 Fax: 886-2-2748-3390	Semtech Switzerland GmbH Japan Branch	Tel: 81-3-6408-0950 Fax: 81-3-6408-0951
Korea Branch	Tel: 82-2-527-4377 Fax: 82-2-527-4376	Semtech Limited (U.K.)	Tel: 44-1794-527-600 Fax: 44-1794-527-601
Shanghai Office	Tel: 86-21-6391-0830 Fax: 86-21-6391-0831	Semtech France SARL	Tel: 33-(0)169-28-22-00 Fax: 33-(0)169-28-12-98
Semtech International AG is a wholly-owned subsidiary of Semtech Corporation, which has its headquarters in the U.S.A.		Semtech Germany GmbH	Tel: 49-(0)8161-140-123 Fax: 49-(0)8161-140-124