

MATERIALS: □ Nickel Plated Brass / Aluminum
-40°F to 212°F

PART NUMBER	MATERIAL	TYPE	MALE THREAD A	FEMALE THREAD B	WRENCHING FLATS W	HEIGHT H	THREAD LENGTH T
AT-1032-BR AT-1216-BR	BRASS	B	1" NPT 1/2" NPT	M32 x 1,5 M16 x 1,5	1.50 (38) .98 (25)	1.61 (41) 1.18 (30)	.98 (25) .79 (20)
AT-1220-BR AT-1225-BR	BRASS	B	1/2" NPT 1/2" NPT	M20 x 1,5 M25 x 1,5	.98 (25) 1.26 (32)	1.18 (30) 1.18 (30)	.79 (20) .79 (20)
AT-3425-BR AT-5432-BR	BRASS	B	3/4" NPT 1-1/4" NPT	M25 x 1,5 M32 x 1,5	1.24 (31.6) 1.67 (42.5)	1.18 (30) 1.30 (33)	0.75 (19) .59 (15)
AN-1407-BR AN-1209-BR	BRASS	A	1/4" NPT 1/2" NPT	PG 7 PG 9	.75 (19) .98 (25)	.98 (25) 1.18 (30)	.59 (15) .79 (20)
AN-1211-BR AN-1213-BR	BRASS	A	1/2" NPT 1/2" NPT	PG 11 PG 13	.98 (25) .98 (25)	1.18 (30) 1.18 (30)	.79 (20) .79 (20)
AN-1221-BR AN-3421-BR	BRASS	A	1/2" NPT 3/4" NPT	PG 21 PG 21	1.30 (33) 1.30 (33)	1.26 (32) 1.22 (31)	.79 (20) .67 (17)
AN-1029-BR AN-5429-BR	BRASS	A	1" NPT 1-1/4" NPT	PG 29 PG 29	1.61 (41) 1.69 (43)	1.38 (35) 1.34 (34)	.98 (25) .94 (24)
AG-0912-BR	BRASS	A	PG 9	1/2" NPT	.94 (24)	.94 (24)	.24 (6)

TYPE - B

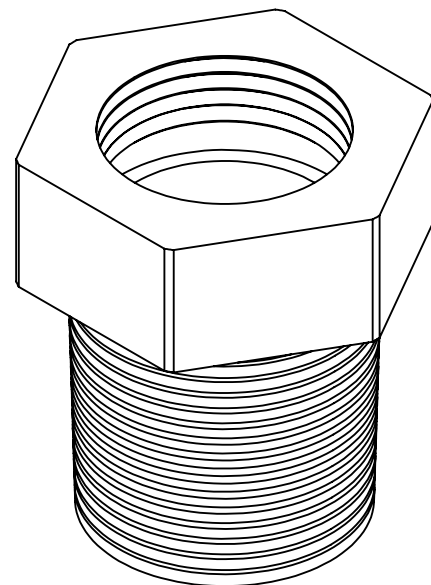

TYPE - A

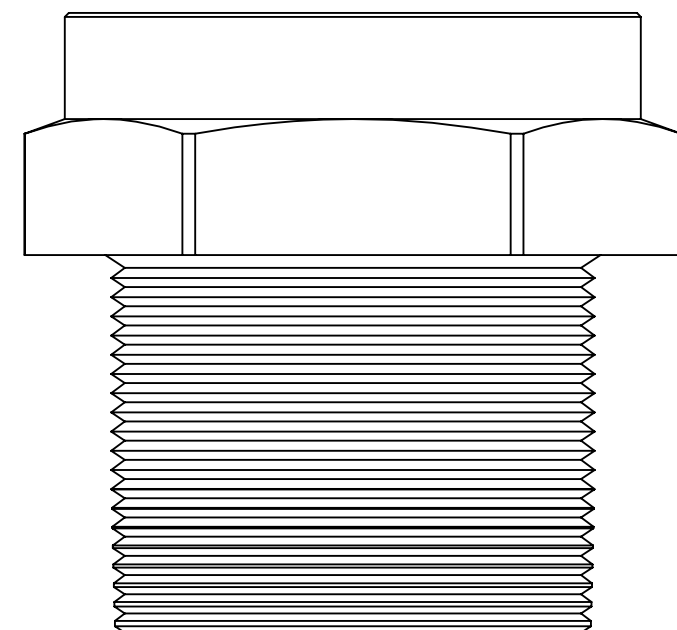

NOTES:

- 1) GENERAL DIMENSIONS DRAWINGS.
- 2) DIMENSIONS [] ARE IN MILLIMETER.
- 3) DIMENSIONS NOTED ARE FOR REFERENCE ONLY.

Third angle projection

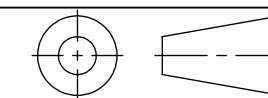

14853 E HINDSDALE AVE, SUITE D
CENTENNIAL, CO 80112-4240, USA
TEL: +1-303-699-1135
TOLL FREE: +1-800-456-9012
E MAIL: info@sealconusa.com,
WEBSITE: www.sealconusa.com

