

*Setting Standards*

## Circular Connectors



# 2010



Setting Standards

[www.hummel.com](http://www.hummel.com)

# HUMMEL AG



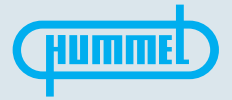

The Products

## Product Range

- Liquid tight strain relief and conduit fittings
- Circular Connectors
- Industrial Enclosures
- Sensing and Control Devices
- Precision turned parts
- Radiator Valves and Fittings
- Installation Enclosures

To request catalog:  
[info@hummel.com](mailto:info@hummel.com)

### Cable Glands



### Industrial Enclosures



## M 23 Fast Ethernet PoE

- + Data transfer up to Gigabit rate, Multibus II capability
- + Hybrid connectors for combined data and power transmission
- + Five separate shield potentials available
- + Rugged, safe, compact: ideal for use in rough industrial environments



# TWINTUS

The new Low-Cost-Standard for Drives

- + Minimized Size
- + Free choice of Signal and Power Inserts
- + Flange 20x20 and 25x25



Colour coded inserts  
(DESINA colour code)



IP 67 (NEMA 4x) self sealing,  
even for threaded bores



Optional EMC-sheet for separating  
signal and power areas

**CONNECTOR  
4 SMALL DRIVES**

**TWINTUS**

## User friendly assembly

- + Clear and modular structure of all connector series
- + Patented modular strain relief insert and contact insert
- + One step cable assembly and shielding
- + Simple, quick and reliable assembly into the connector housing



Colour coding of spacers for male and female inserts



Cable assembly and shielding is possible in a single operation.



Strain relief insert with four fingers, secured in a recess, prevents cable rotation.



Flexible EMC-O-ring guarantees reliable EMC-protection for light and heavy braided shields.

# Robust – simple & small!



Design allows for terminated patch cable



Integrated coupler accommodates off-the-shelf RJ45 patch cables.



Integrated cable strain relief warrants an IP 67 / IP 69 K rating making the M23 based RJ45 Connector an ideal solution for robust applications.



A standard RJ45 connection is suitable as service and programmable interface.

# SLS-Technology

The new, high performance type of contacts – HUMMEL SLS-Technology (Spring Loaded Socket)

- + Integrated spring mates with the pin contact and encompasses it radially
- + Exceptional electrical performance with ultimate contact reliability
- + Tinned solder contacts assure easy and quick assembly

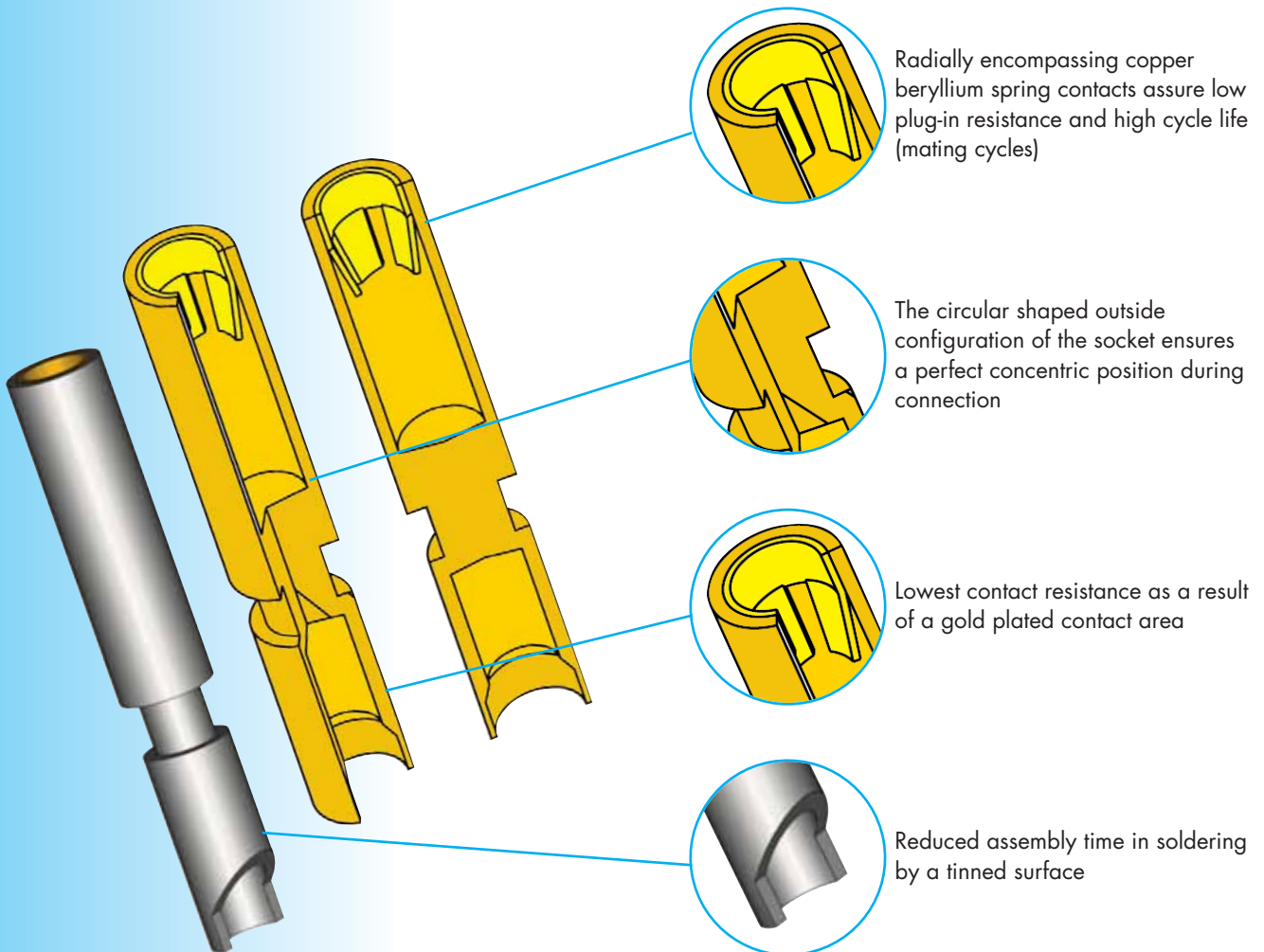



# Euro-Lock-System<sup>®</sup>

Euro-Lock-System<sup>®</sup> – the patented locking system

- + The integrated locking clip secures the contacts in the insert
- + Easy assembly and disassembly of the contacts
- + No special tools required

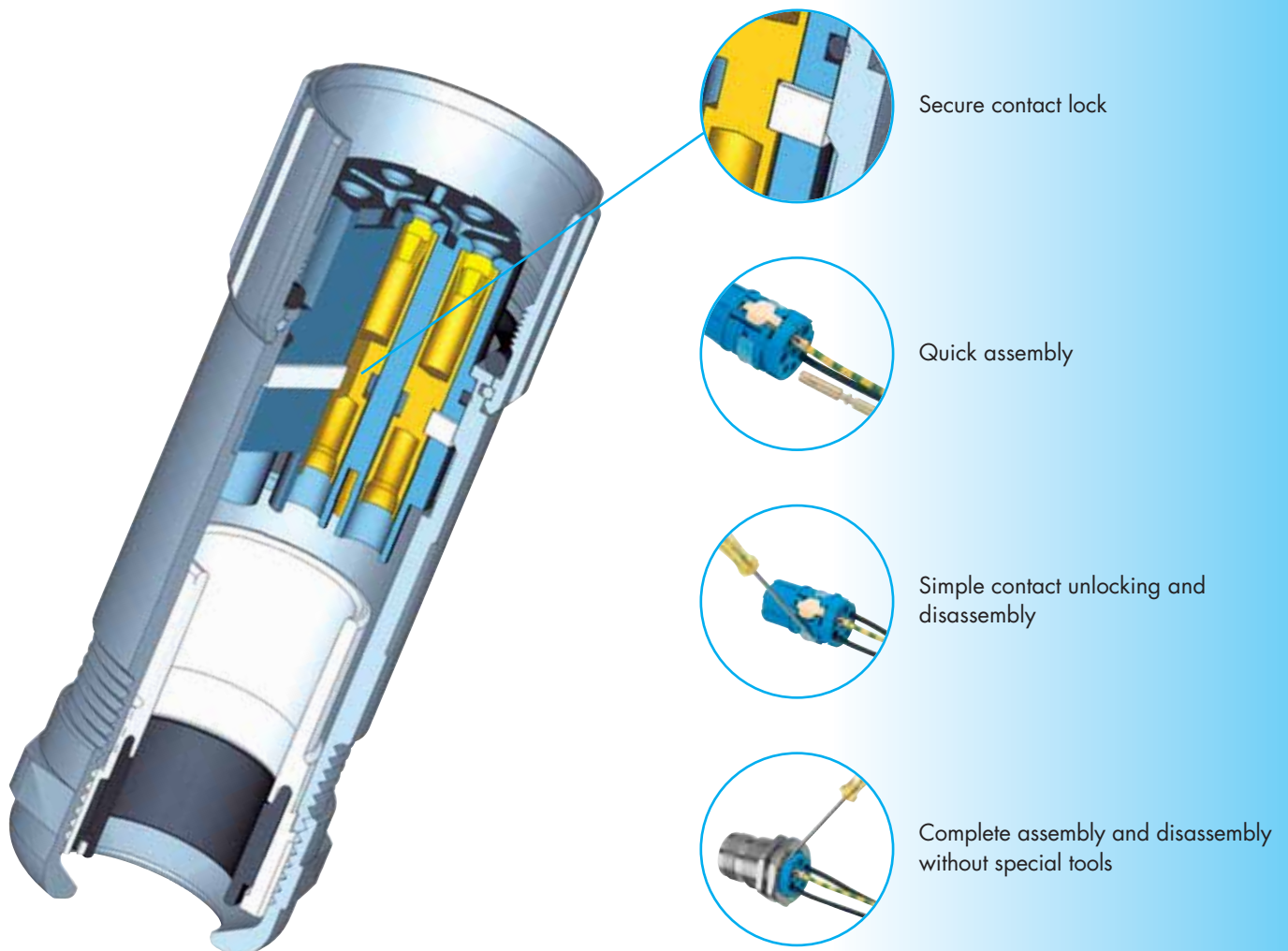

# Push-Pull Technology

- + One for all: Standard male connectors accept HUMMEL Push-Pull as well as screw connection
- + EMC proof due to metal sleeve
- + Optional safety ring

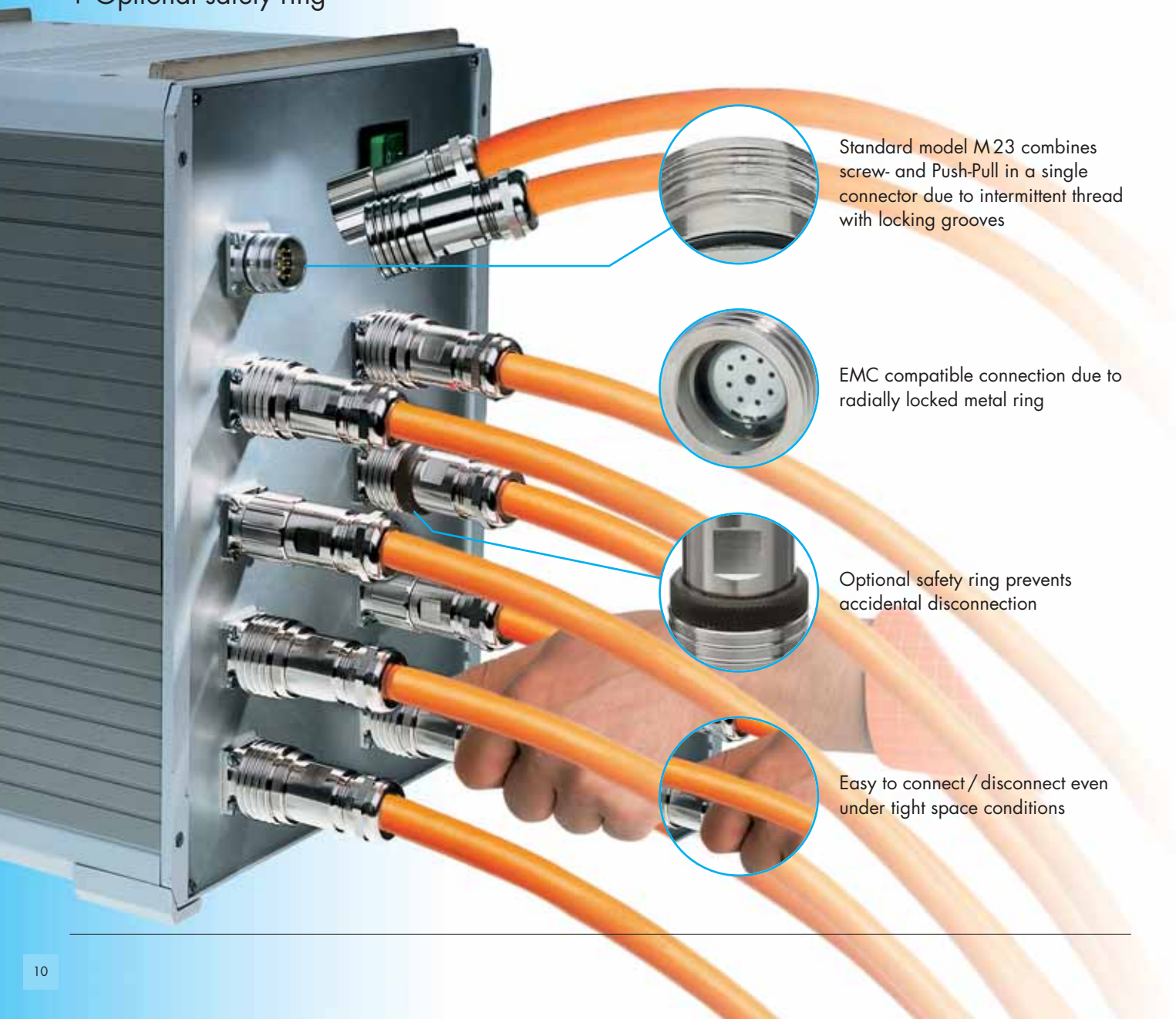

Standard model M23 combines screw- and Push-Pull in a single connector due to intermittent thread with locking grooves

EMC compatible connection due to radially locked metal ring

Optional safety ring prevents accidental disconnection

Easy to connect / disconnect even under tight space conditions

# Unique Benefits

- + Interchangeability of pin or socket inserts in every style connector housing
- + HUMMEL's patented integrated HSK Liquid Tight Strain Relief Fitting
- + Internationally certified exceptional quality



File-No. E 213337



Germanischer Lloyd

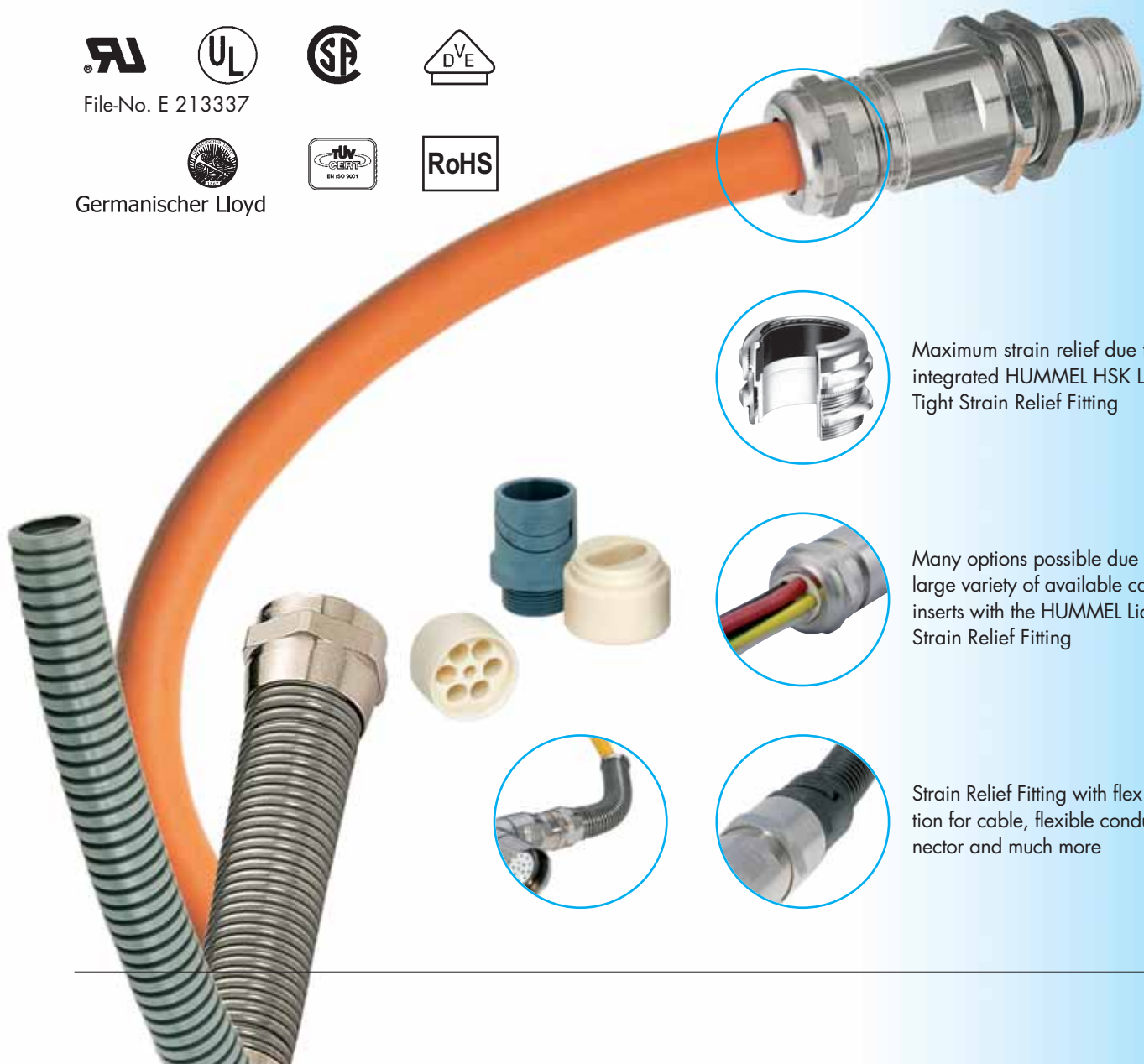

Maximum strain relief due to the integrated HUMMEL HSK Liquid Tight Strain Relief Fitting



Many options possible due to the large variety of available cable seal inserts with the HUMMEL Liquid Tight Strain Relief Fitting







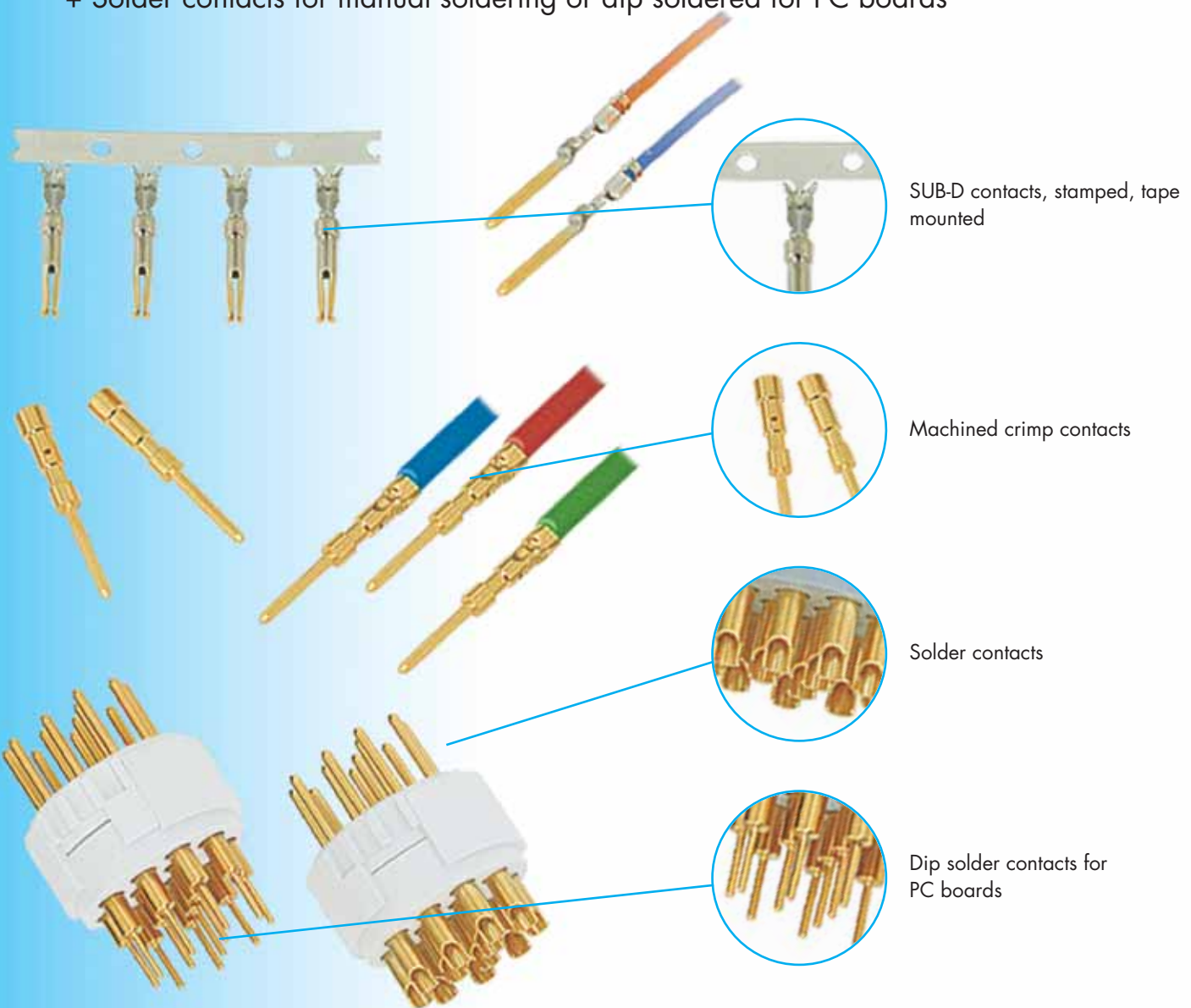

Strain Relief Fitting with flex protection for cable, flexible conduit connector and much more

# The Insert – One for all

- + Insert can be used for all types of contacts
- + Crimp contacts machined or on tape
- + Solder contacts for manual soldering or dip soldered for PC boards



<b>Setting the Standards</b>	page 4
<b>Technical Information</b>	page 14
<b>Connectors M 16</b>	
page 15	
<b>Connectors M 23 Fast Ethernet PoE</b>	
page 41	
<b>Connectors M 23 RJ45</b>	
page 53	
<b>Connectors Signal Size 1 M 23</b>	
page 63	
<b>Connectors Signal Size 1 M 27</b>	
page 95	
<b>Connectors Power Size 1 M 23</b>	
page 105	

<b>Connectors Power Size 1,5 M 40</b>	
page 129	
<b>Connectors Push-Pull Technology</b>	
page 149	
<b>Connectors Stainless Steel (INOX)</b>	
page 159	
<b>Moulded Cordsets M 23</b>	
page 167	

<b>Custom Solutions</b>	page 172
<b>Page Finder</b>	page 178
<b>HUMMEL International</b>	page 179

### Technical Information

**Nominal Current**

Allowable current (Amp), that can be transmitted by each contact continuously and simultaneously.

**Nominal Voltage**

Allowable voltage (Volt), that can be applied to each contact continuously and simultaneously.

**Test Voltage**

Voltage which, under certain conditions, a connector can be exposed to without breakdown.

**Degree of Protection**

Potential dirt accumulation of a disconnected connector in a certain environment.

**Degree of Protection 2**

No permanent conductive dirt accumulation will occur. Temporary conductive dirt accumulation, such as condensation, is possible. Typical for households, offices, laboratories and test labs.

**Degree of Protection 3**

Conductive, as well as dry non-conductive dirt accumulation can occur. It can be temporarily conductive due to condensation. Typical for industrial and factory environments.

**Additional remarks (pollution level)**

If connectors being defined for pollution degree 1 and overvoltage category 1 are applied for other conditions (higher pollution degree and higher overvoltage category) voltages level reduce correspondingly. But the connectors can be used without any problems at reduced maximum voltages.

**Mating cycles**

Mating cycles are the number of insertion and extraction cycles a connector can withstand before the electrical or mechanical failure in relationship to the connector's design specification.

**Air gap**

The minimum gap of air between two conducting surfaces permissible at given voltage.

**Creep distance**

The minimum dimension along the surface of an insulating material between two conducting surfaces.

**PE**

The PE-Contact is a ground contact for security reasons.

---

**Safety Guidelines**

When Hummel connectors are used for voltages greater than 50 Volts with conductive shell components they must be used in accordance with the safety regulations DIN VDE Part 410; IEC 60364-4-41. This regulation basically dictates that the power source should be turned off before mating and unmating connector. This regulation does not provide protection against electrical shock when mating and unmating connectors in the field.

---



Don't connect or disconnect HUMMEL Connectors under load.

## Connectors M 16

**T**WINTUS  
inclusive



Housings

page 18



Inserts

page 22

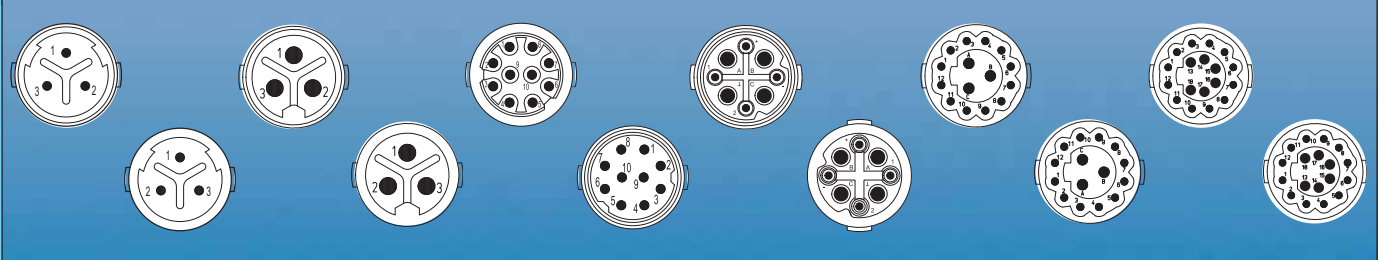

Accessories

page 29





## M 16 Control Signal Connectors

Mechanical Data	Materials and Technical Data
Housing	Copper-Zinc alloy Die Casting Aluminium alloy
Housing surface	Nickel plated other surface upon request
Inserts (for contacts)	Thermoplastic Polyamid PA 6 (Nylon 6/6), PBT    Fire protection class V-0
Contacts	Brass Alloy
Contact surface at point of contact	Nickel and gold plated (0,25µm Au)
Minimum mating cycles	> 1000
Seals / O-Rings	Buna-N standard, optional Viton® (Viton is a registered trademark of DuPont)
Temperature range	-40° C – 125° C (-40 °F – 257 °F)
Type of contacts	Crimp, solder, dip-solder (PCB)
Protection	IP 67 / IP 69K per EN 60 529 (connected), NEMA 4x
Cable diameter range	2 – 11 mm (.08 – .43")

Electrical Data					
Number of positions	3 (3 x 1 mm)	3 (3 x 2 mm)	4 + 3 + PE / 320V		4 + 3 + PE / 630V <sup>5)</sup>
Number of contacts	3	3	4	4	4    4
ContactØ [mm]	1	2	0,8	1,6	0,8    1,25
AWG [mm <sup>2</sup> ]	0,14 – 1	0,5 – 2,5	0,08 – 0,34	0,34 – 1,5	0,08 – 0,34    0,34 – 1,5
Nominal current <sup>1)</sup> [A]	8	20	5	16	5    16
Nominal voltage <sup>2)</sup> [V~] degree of protection 2 <sup>4)</sup>	630	630	320	630	300    800
Nominal voltage <sup>2)</sup> [V~] degree of protection 3 <sup>4)</sup>	400	400	160	320	300    630
Test voltage (Breakdown voltage) <sup>3)</sup> [V~]	2500	2500	1500	2500	1500    2500
Insulation resistance [MΩ]	> 10 <sup>10</sup>	> 10 <sup>10</sup>	> 10 <sup>10</sup>		> 10 <sup>10</sup>
Max. contact resistance [mΩ]	3	3	3		3    3
Number of positions		10	12 + 3		18
Number of contacts		10	12	3	18
ContactØ [mm]		1	0,8	1,25	0,8
AWG [mm <sup>2</sup> ]		0,14 – 0,75	0,08 – 0,34	0,5 – 1,5	0,08 – 0,34
Nominal current <sup>1)</sup> [A]		8	3	10	3
Nominal voltage <sup>2)</sup> [V~] degree of protection 2 <sup>4)</sup>		230	60	160	60
Nominal voltage <sup>2)</sup> [V~] degree of protection 3 <sup>4)</sup>		160	24	60	24
Test voltage (Breakdown voltage) <sup>3)</sup> [V~]		1500	1500	2500	1500
Insulation resistance [MΩ]		> 10 <sup>6</sup>	> 10 <sup>10</sup>		> 10 <sup>10</sup>
Max. contact resistance [mΩ]		3	3	3	3

<sup>1)</sup>, <sup>2)</sup>, <sup>3)</sup>, <sup>4)</sup> See Technical Information page 14    <sup>5)</sup> Under development

## Connectors M 16 / Housing

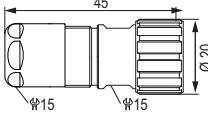
Straight Connector, Female Thread		Cable-Ø	Part Number
		2 – 7 mm (.08 – .28").....	7.810.300.000
		5 – 9 mm (.20 – .35").....	7.810.400.000
		Contacts and inserts page 22 • Assembly instructions page 34 / 35	

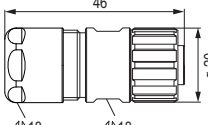
Straight Connector, Female Thread		Cable-Ø	Part Number
		8 – 11 mm (.31 – .43").....7.810.5000.00	
		Contacts and inserts page 22 • Assembly instructions page 34 / 35	

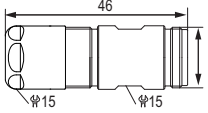
Straight Connector, Male Thread		Cable-Ø	Part Number
		2 – 7 mm (.08 – .28").....	7.820.300.000
		5 – 9 mm (.20 – .35").....	7.820.400.000
		Contacts and inserts page 22 • Assembly instructions page 34 / 35	

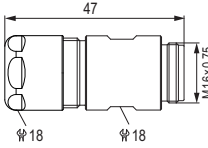
Straight Connector, Male Thread		Cable-Ø	Part Number
		8 – 11 mm (.31 – .43").....7.820.5000.00	
		Contacts and inserts page 22 • Assembly instructions page 34 / 35	

Cable-Ø	Part Number	Right Angle Connector, Female Thread
2 – 7 mm (.08 – .28")	7.830.300.000	
5 – 9 mm (.20 – .35")	7.830.400.000	

Contacts and inserts page 22 • Assembly instructions page 36



Assembly tool 7.010.900.125 is required

Cable-Ø	Part Number	Right Angle Connector with positioning
2 – 7 mm (.08 – .28")	7.831.300.000	
5 – 9 mm (.20 – .35")	7.831.400.000	
8 – 11 mm (.31 – .43")	7.831.500.000	

Contacts and inserts page 22 • Assembly instructions page 37



Cable-Ø	Part Number	Panel Connector with built in Cable Strain Relief
<b>Rear mounting, single hole mounted</b>		
2 – 7 mm (.08 – .28")	7.852.300.000	
5 – 9 mm (.20 – .35")	7.852.400.000	

Including jam nut PG 11

Contacts and inserts page 22 • Assembly instructions page 34 / 35



Cable-Ø	Part Number	Panel Connector with built in Cable Strain Relief
<b>Rear mounting, M2,5 x 4 single hole mounted</b>		
2 – 7 mm (.08 – .28")	7.847.300.000	
5 – 9 mm (.20 – .35")	7.847.400.000	

Contacts and inserts page 22 • Assembly instructions page 34 / 35



## Connectors M 16 / Housing

Panel Connector, Male Thread, Front Mounting	Type	Part Number
	4 x holes $\varnothing$ 2,7 mm (.11") ..7.840.000.000 Flange 20 x 20 mm	
	4 x holes $\varnothing$ 2,7 mm.....7.840.100.000 Flange 25 x 25 mm	
Contacts and inserts page 22 • Assembly instructions page 38		

Panel Connector, Male Thread, Front Mounting	Type	Part Number
	<b>Short version</b> 4 x holes $\varnothing$ 2,7 mm (.11") ..7.840.200.000 Flange 20 x 20 mm	
	Contacts and inserts page 22 • Assembly instructions page 38	

Right Angle Panel Connector, Male Thread	Type	Part Number
	<b>300° rotating, locking screw at flange</b> 4 x holes $\varnothing$ 2,7 mm (.11") ..7.843.000.000 Flange 20 x 20 mm	
	4 x holes $\varnothing$ 2,7 mm.....7.843.100.000 Flange 25 x 25 mm	
Contacts and inserts page 22 • Assembly instructions page 39		

Panel Connector, Male Thread	Type	Part Number
	<b>Front mounting, single hole mounted</b> Thread M 16 x 1,5 .....7.842.000.000	
	Contacts and inserts page 22 • Assembly instructions page 38	



Type	Part Number	Panel Connector, Male Thread	
<b>Rear mounting, single hole mounted</b> Including jam nut.....	7.850.000.000		
Contacts and inserts page 22 • Assembly instructions page 38			



Type	Part Number	Panel Connector, Male Thread	
<b>Rear mounting, 4 x thread M 2,5</b> Flange 20 x 20 mm .....	7.845.000.000		
Contacts and inserts page 22 • Assembly instructions page 38			

Type	Part Number	TWINTUS	
Flange 20 x 20 mm Surface blank .....	7.848.000.000		
Surface nickel plated .....	7.848.000.001		
Surface black conductive.....	7.848.000.00B		
Contacts and inserts page 22 • Assembly instructions page 33			

Type	Part Number	TWINTUS	
Flange 25 x 25 mm Surface blank .....	7.848.100.000		
Surface nickel plated .....	7.848.100.001		
Surface black conductive.....	7.848.100.00B		
Contacts and inserts page 22 • Assembly instructions page 33			

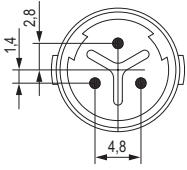
## Connectors M 16 / Inserts / Pinouts

Inserts 3-pole (3 x 1 mm)		Type	Part Number	Part Number
			Pins	Sockets
 <p>Insert pin mating view</p>	Insert			
	without contacts .....	7.003.903.101 .....	7.003.903.102	
	Insert with dip solder contacts			
	Length 10 mm .....	7.001.903.127 .....	7.001.903.108	
	Insert with dip solder contacts			
	Length 17 mm .....	7.001.903.137 .....	7.001.903.118	
 <p>Insert socket mating view</p>	<b>Required Contacts</b>			
	3 x 1 mm .....	7.010.901.001 .....	7.010.901.002 / 7.010.901.012	
	Contacts page 26-28			

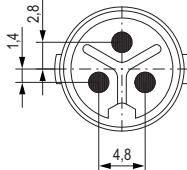
Inserts 3-pole (3 x 2 mm)		Type	Part Number	Part Number
			Pins	Sockets
 <p>Insert pin mating view</p>	Insert			
	without contacts .....	7.003.983.101 .....	7.003.983.102	
	Insert with dip solder contacts			
	Length 10 mm .....	7.001.983.127 .....	7.001.983.108	
	Insert with dip solder contacts			
	Length 17 mm .....	7.001.983.137 .....	7.001.983.118	
 <p>Insert socket mating view</p>	<b>Required Contacts</b>			
	3 x 2 mm .....	7.010.982.001 .....	7.010.982.002	
	Contacts page 26-28			

Type	Part Number	Part Number	Inserts 4+3+PE
	<b>Pins</b>	<b>Sockets</b>	
Insert without contacts .....	7.003.943.101 .....	7.003.943.102	<p>Insert pin mating view</p>
Insert RAL 2003 (DESINA orange) without contacts .....	7.053.943.101 .....	7.053.943.102	
Insert with dip solder contacts Length 10 mm .....	7.001.943.127 .....	7.001.943.108	<p>Insert socket mating view</p>
Insert with dip solder contacts Length 17 mm .....	7.001.943.137 .....	7.001.943.118	
<b>Required Contacts</b>			
4 x 0,8 mm .....	7.010.980.801 .....	7.010.980.802	
4 x 1,6 mm .....	7.010.981.601 .....	7.010.981.602	
Contacts page 26-28			

Type	Part Number	Part Number	Inserts 4+3+PE 630 V <sup>1)</sup>
	<b>Pins</b>	<b>Sockets</b>	
Insert without contacts <sup>1)</sup> .....	7.003.908.101 .....	7.003.908.102	<p>Insert pin mating view</p>
Insert RAL 2003 (DESINA orange) without contacts <sup>1)</sup> .....	7.053.908.101 .....	7.053.908.102	
Insert with dip solder contacts Length 10 mm <sup>1)</sup> .....	7.003.908.127 .....	7.003.908.108	<p>Insert socket mating view</p>
Insert with dip solder contacts Length 17 mm <sup>1)</sup> .....	7.003.908.137 .....	7.003.908.118	
<b>Required Contacts</b>			
4 x 0,8 mm .....	7.010.980.901 .....	7.010.980.802	
4 x 1,25 mm .....	7.010.981.211 .....	7.010.981.212	
Contacts page 26-28			

<sup>1)</sup> Under development

## Connectors M 16 / Inserts / Pinouts

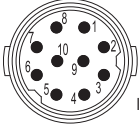
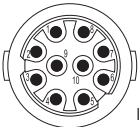
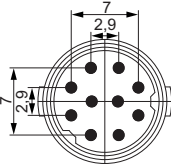
Inserts 10-pole	Type	Part Number	Part Number
		Pins	Sockets
 <p>Insert pin mating view</p>	Insert		
	without contacts .....	7.003.910.101	7.003.910.102
 <p>Insert socket mating view</p>	Insert RAL 6018 (DESINA green)		
	without contacts .....	7.053.910.101	7.053.910.102
	Insert with dip solder contacts		
	Length 10 mm .....	7.001.910.127	7.001.910.108
	Insert with dip solder contacts		
	Length 17 mm <sup>1)</sup> .....	7.001.910.137	7.001.910.118
	<b>Required Contacts</b>		
	10 x 1 mm .....	7.010.981.001	7.010.981.002

Contacts page 26-28

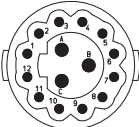
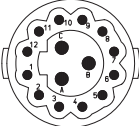
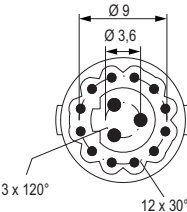
Inserts 12+3-pole	Type	Part Number	Part Number
		Pins	Sockets
 <p>Insert pin mating view</p>	Insert		
	without contacts .....	7.003.985.101	7.003.985.102
 <p>Insert socket mating view</p>	Insert with dip solder contacts		
	Length 10 mm .....	7.001.985.127	7.001.985.108
	Insert with dip solder contacts		
	Length 17 mm .....	7.001.985.137	7.001.985.118

Contacts page 26-28



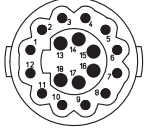
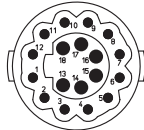

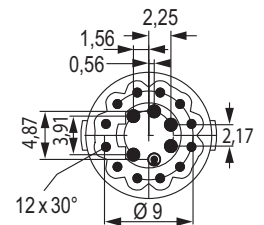



Type	Part Number	Part Number	Inserts 18-pole
	<b>Pins</b>	<b>Sockets</b>	
Insert without contacts .....	7.003.988.101 .....	7.003.988.102	 <p>Insert pin mating view</p>
Insert RAL 6018 (DESINA green) without contacts .....	7.053.988.101 .....	7.053.988.102	
Insert with dip solder contacts Length 10 mm .....	7.001.988.127 .....	7.001.988.108	 <p>Insert socket mating view</p>
Insert with dip solder contacts Length 17 mm .....	7.001.988.137 .....	7.001.988.118	

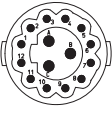

Contacts page 26-28

## Connectors M 16 / Required Contacts

Contact Arrangement	Number of Poles	Required Contacts	Type	Part Number
	3 (3 x 1)	3 x 1 mm	Pins Sockets	7.010.901.001 7.010.901.002
	3 (3 x 2)	3 x 2 mm	Pins Sockets	7.010.982.001 7.010.982.002
	4 + 3 + PE	4 x 0,8 mm 4 x 1,6 mm	Pins Sockets Pins Sockets	7.010.980.801 7.010.980.802 7.010.981.601 7.010.981.602
	4 + 3 + PE 630 V	4 x 0,8 mm 4 x 1,25 mm	Pins Sockets Pins Sockets	7.010.980.801 7.010.980.802 7.010.981.211 7.010.981.212
	10	10 x 1 mm	Pins Sockets	7.010.981.001 7.010.981.002
	15 (12 + 3)	12 x 0,8 mm 3 x 1,25 mm	Pins Sockets Pins Sockets	7.010.980.801 7.010.980.802 7.010.981.201 7.010.981.202
	18	18 x 0,8 mm	Pins Sockets	7.010.980.801 7.010.980.802

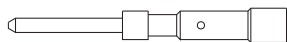
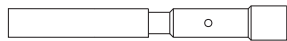
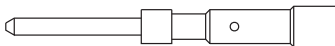
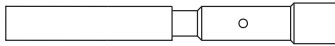
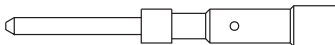
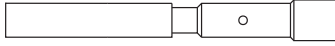
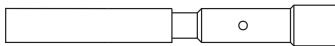
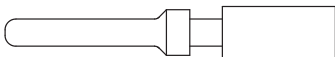
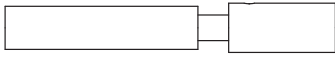
Type	Crimp Range	Part Number	Contacts
Crimp pin 0,8 mm, machined.....	0,08 – 0,34 mm <sup>2</sup> (AWG 28 – 22)	7.010.980.801	
Crimp socket 0,8 mm, machined.....	0,08 – 0,34 mm <sup>2</sup> (AWG 28 – 22)	7.010.980.802	
Crimp pin 1 mm, machined.....	0,08 – 0,75 mm <sup>2</sup> (AWG 28 – 18)	7.010.981.001	
Crimp socket 1 mm, machined.....	0,08 – 0,75 mm <sup>2</sup> (AWG 28 – 18)	7.010.981.002	
Crimp pin 1 mm, machined.....	0,14 – 1 mm <sup>2</sup> (AWG 26 – 17)	7.010.901.001	
Crimp socket 1 mm, machined.....	0,08 – 0,56 mm <sup>2</sup> (AWG 28 – 20)	7.010.901.012	
Crimp socket 1 mm, machined.....	0,34 – 1 mm <sup>2</sup> (AWG 22 – 17)	7.010.901.002	
Crimp pin 1,25 mm, machined.....	0,5 – 1,5 mm <sup>2</sup>	7.010.981.201	
Crimp socket 1,25 mm, machined.....	0,5 – 1,5 mm <sup>2</sup>	7.010.981.202	

Please see assembly instructions on page 40

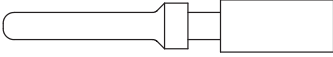
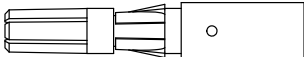
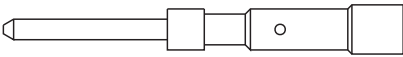
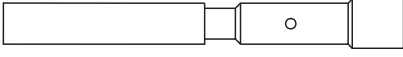
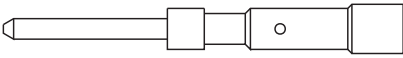
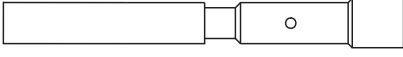
Contacts	Type	Crimp Range	Part Number
	Crimp pin 1,25 mm, machined.....	0,5 – 1,5 mm <sup>2</sup> .....	7.010.981.211
	Crimp socket 1,25 mm, machined.....	0,5 – 1,5 mm <sup>2</sup> .....	7.010.981.212
	Crimp pin 1,6 mm, machined.....	0,34 – 1,5 mm <sup>2</sup> (AWG 22 – 16) ..	7.010.981.601
	Crimp socket 1,6 mm, machined.....	0,34 – 1,5 mm <sup>2</sup> (AWG 22 – 16) ....	7.010.981.602
	Crimp pin 2 mm, machined.....	1,0 – 2,5 mm <sup>2</sup> .....	7.010.982.001
	Crimp socket 2 mm, machined.....	1,0 – 2,5 mm <sup>2</sup> .....	7.010.982.002

Crimp Tool Settings see page 31 / 32  
Please see assembly instructions on page 40

Type	Part Number	Accessories
Plastic protective cap for connectors with male thread .....7.000.980.161 for connectors with female thread.....7.000.980.162		
Brass protective cap for connectors with female thread.....7.010.900.163		
Brass protective cap for connectors with male thread .....7.010.900.162		
Brass protective cap with chain for connectors with female thread .....Length 70 mm .....7.010.9S0.705		
Brass protective cap with chain for connectors with male thread .....Length 70 mm .....7.010.9S0.704		
Assembly tool for Right Angle Connector M 16 .....7.010.900.125		

## Connectors M 16 / Accessories

Accessories	Type	Part Number
	Crimp tool for manual crimping of machined crimp contacts for signal connectors M 16 and M 23 .....	7.000.900.904
See page 84 for crimp tool instructions		
	Adaptor flange for Straight Connectors .....	7.010.900.135
	Conduit adaptor	DN 10 .....7.010.900.200 Snapflex 16.....7.010.900.201 DN 12 .....7.010.900.202 Snapflex 16.....7.010.900.203
	EMC-sheet for TWINTUS Flange 20 x 20 ..... for TWINTUS Flange 25 x 25 .....	7.040.848.101 7.040.848.102

Please see assembly instructions on page 34

## Crimp Tool for Connectors M 16

### Crimp Tool Setting for HUMMEL Crimp Contacts (Crimp Tool 7.000.900.904)

Part Number	Crimp Contact	Cross Section (mm <sup>2</sup> )	AWG	Crimp Tool Setting mm	Locator Setting
7.010.980.801	Crimp pin 0,8 mm	0,08	AWG 28	0,57	10
		0,14	AWG 26	0,60	
		0,25	AWG 24	0,64	
		0,34	AWG 22	0,73	
7.010.980.802	Crimp socket 0,8 mm	0,08	AWG 28	0,57	10
		0,14	AWG 26	0,60	
		0,25	AWG 24	0,64	
		0,34	AWG 22	0,73	
7.010.981.001	Crimp pin 1 mm	0,08	AWG 28	0,60	7
		0,14	AWG 26	0,65	
		0,25	AWG 24	0,67	
		0,34	AWG 22	0,71	
		0,56	AWG 20	0,75	
		0,75	AWG 18	0,82	
7.010.981.002	Crimp socket 1 mm	0,08	AWG 28	0,60	8
		0,14	AWG 26	0,63	
		0,25	AWG 24	0,66	
		0,34	AWG 22	0,69	
		0,56	AWG 20	0,75	
		0,75	AWG 18	0,83	
7.010.901.001	Crimp pin 1 mm	0,14	AWG 26	0,70	1
		0,25	AWG 24	0,76	
		0,34	AWG 22	0,82	
		0,50	AWG 20	0,90	
		0,75	AWG 18	1,00	
		1,0	AWG 17	1,10	
7.010.901.012	Crimp socket 1 mm (0,08-0,56 mm <sup>2</sup> )	0,08	AWG 28	0,75	2
		0,14	AWG 26	0,78	
		0,25	AWG 24	0,82	
		0,34	AWG 22	0,86	
		0,56	AWG 20	0,90	
7.010.901.002	Crimp socket 1 mm (0,34 – 1 mm <sup>2</sup> )	0,34	AWG 22	0,77	2
		0,56	AWG 20	0,82	
		0,75	AWG 18	0,88	
		1,0	AWG 17	0,95	

These values are only guidelines and actual conductor cross sections depend on manufacturer tolerances.

See page 40 for crimp tool instructions

## Crimp Tool for Connectors M 16

### Crimp Tool Setting for HUMMEL Crimp Contacts (Crimp Tool 7.000.900.904)

Part Number	Crimp Contact	Cross Section (mm <sup>2</sup> )	AWG	Crimp Tool Setting mm	Locator Setting
7.010.981.201	Crimp pin 1,25 mm	0,5	AWG 20	0,70	2
		0,75	AWG 18	0,73	
		1,0	AWG 17	0,79	
		1,5	AWG 16	0,88	
7.010.981.202	Crimp socket 1,25 mm	0,5	AWG 20	0,70	2
		0,75	AWG 18	0,73	
		1,0	AWG 17	0,79	
		1,5	AWG 16	0,88	
7.010.981.601	Crimp pin 1,6 mm	0,34	AWG 22	0,80	6
		0,56	AWG 20	0,84	
		0,75	AWG 18	0,90	
		1,0	AWG 17	1,00	
		1,5	AWG 16	1,10	
7.010.981.602	Crimp socket 1,6 mm	0,34	AWG 22	0,83	9
		0,56	AWG 20	0,90	
		0,75	AWG 18	0,97	
		1,0	AWG 17	1,02	
		1,5	AWG 16	1,10	
7.010.982.002	Crimp socket 2 mm	1,0	AWG 17	1,35	4
		1,5	AWG 16	1,45	
		2,5	AWG 14	1,60	
7.010.982.001	Crimp pin 2 mm	1,0	AWG 17	1,35	5
		1,5	AWG 16	1,45	
		2,5	AWG 14	1,60	

These values are only guidelines and actual conductor cross sections depend on manufacturer tolerances.

See page 40 for crimp tool instructions



TWINTUS

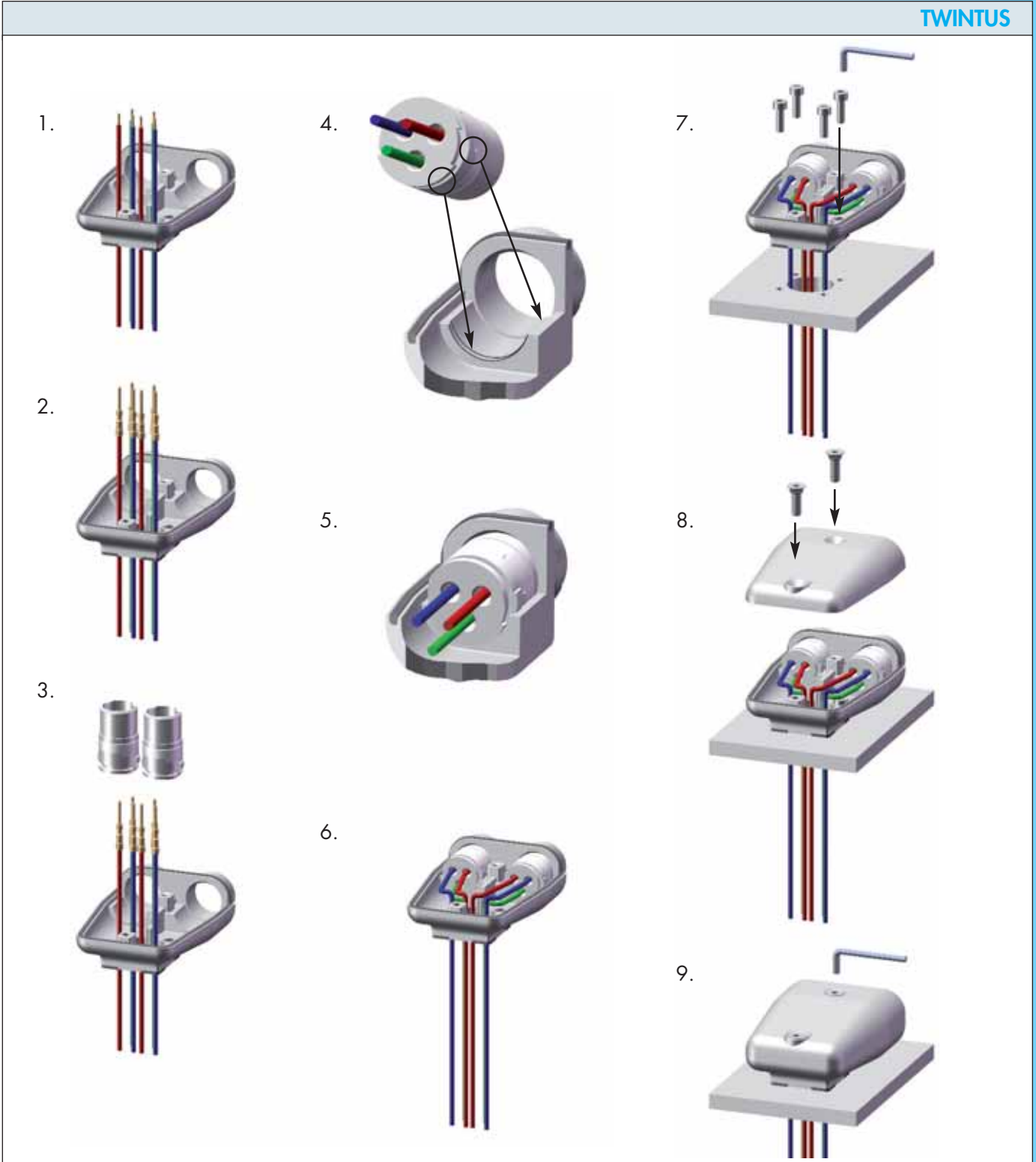

# Connectors M 16 / Assembly Instructions

## Female Threaded Connector / Male Threaded Connector

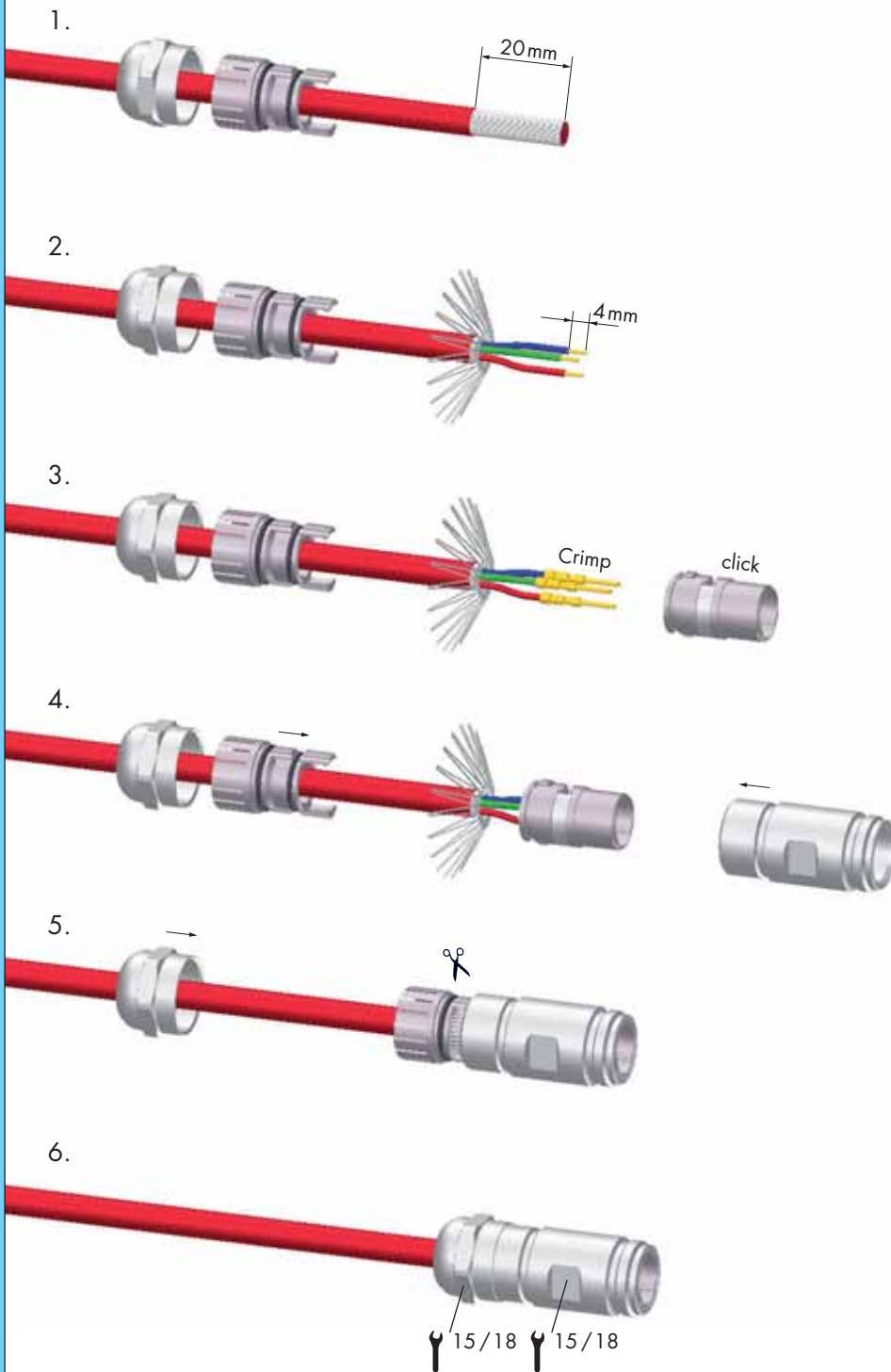

## Female Threaded Connector / Male Threaded Connector 12+3

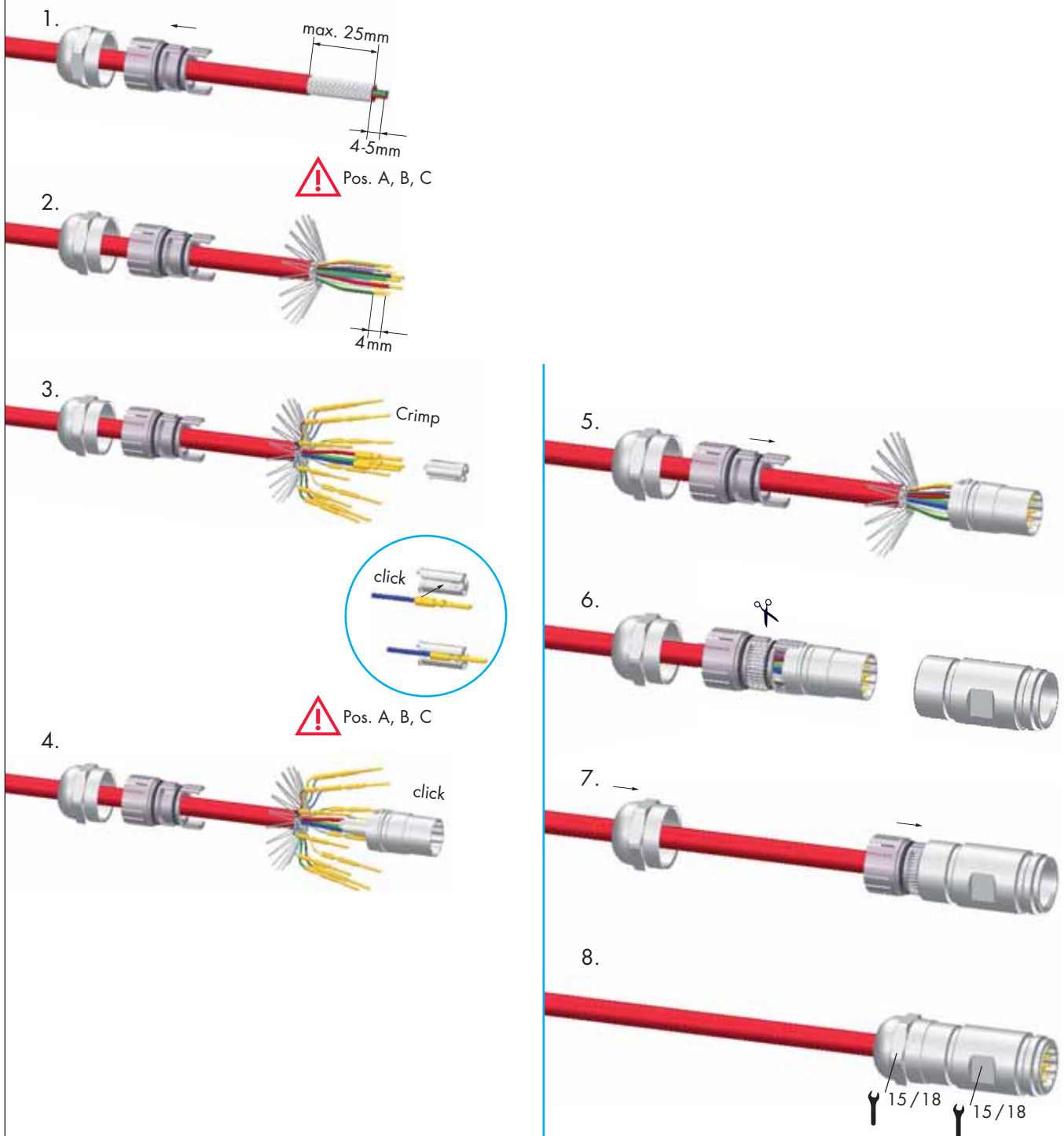

## Right Angle Connectors

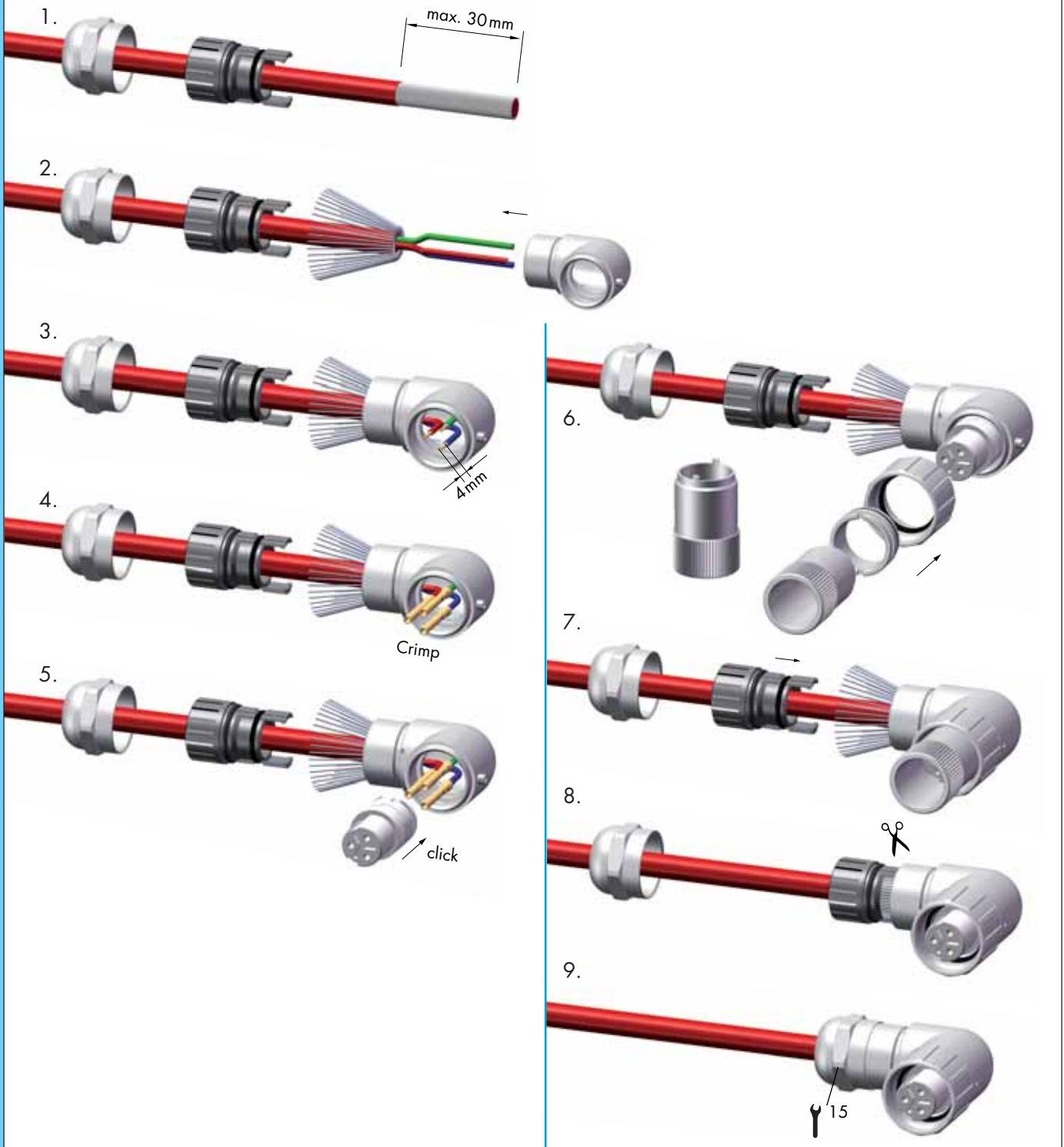

# Connectors M 16 / Assembly Instructions

## Right angle connector with positioning

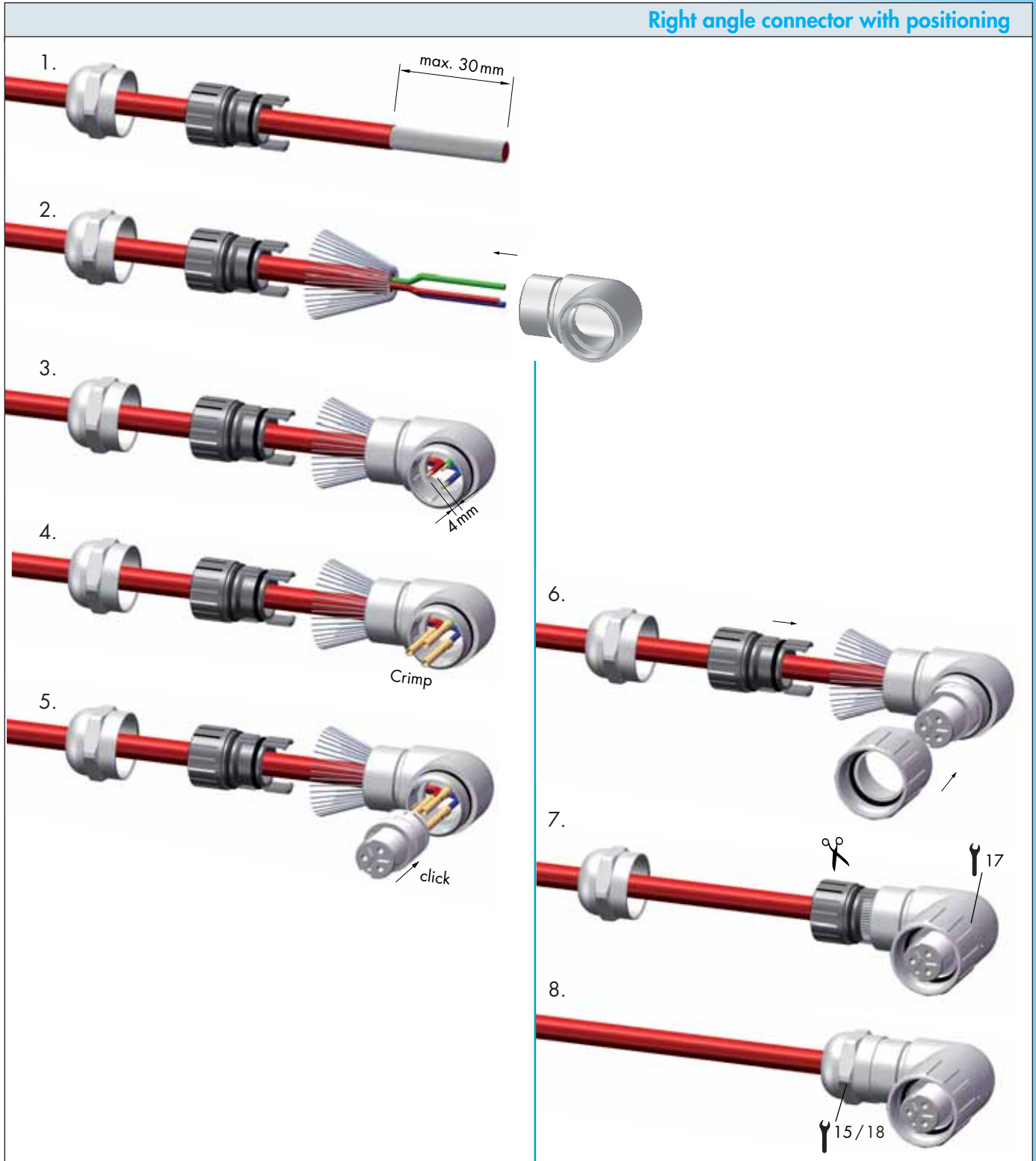

# Connectors M 16 / Assembly Instructions

## Panel Connector

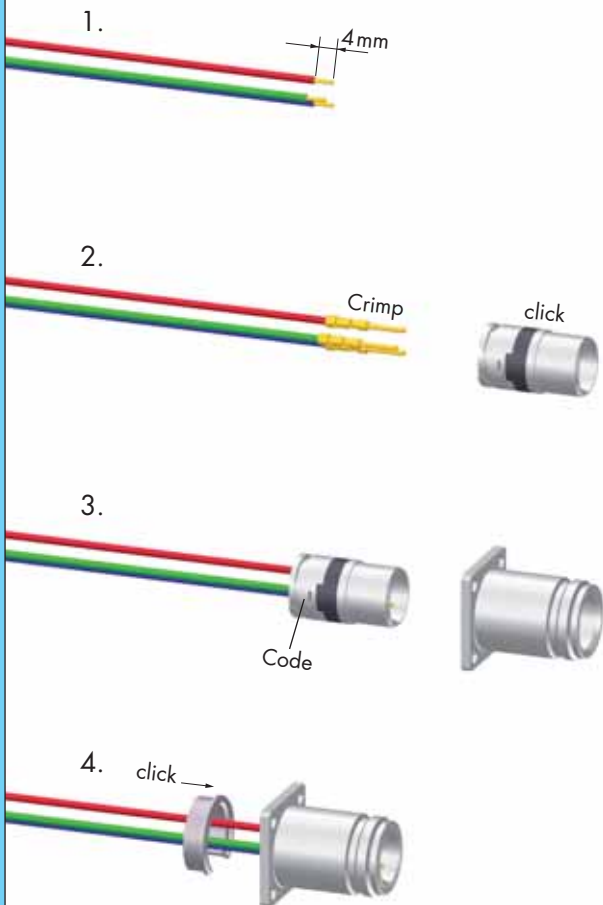

## Right Angle Panel Connector

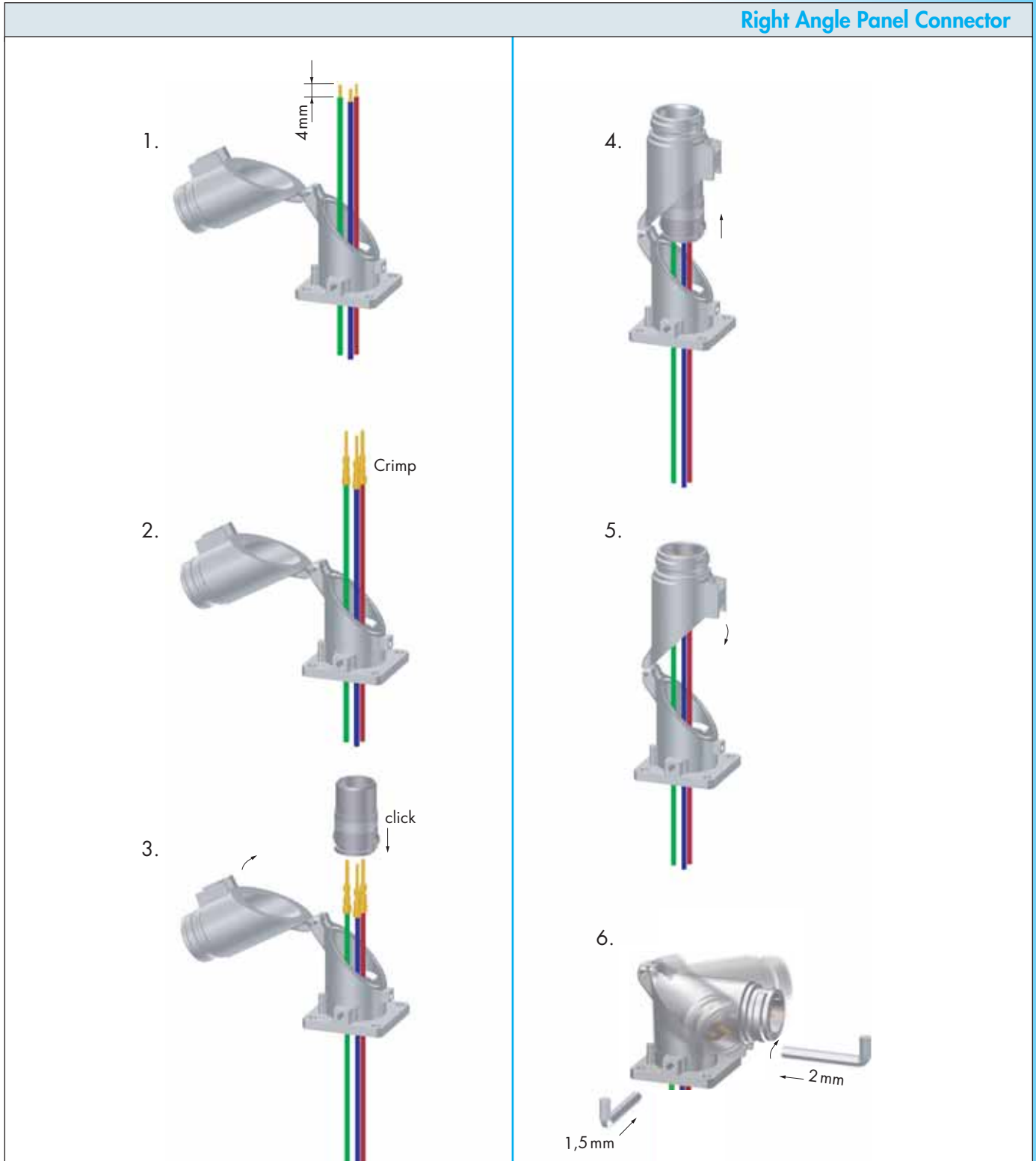

## Crimping, Assembly and Disassembly of Contacts

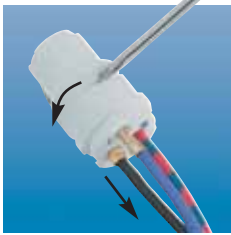

### Crimping

- Remove conductor insulation 4 mm (.16") max.
- Select appropriate Crimp tool setting (see page 31 - 32)
- Push crimp contact into opening of crimping tool
- Insert stripped wire into the funnel shaped end of the crimp contact
- Squeeze handles of crimping tool together connect contact to wire

### Assembly

- Remove crimped assembly and pull on wire to test connection
- Push into desired position of insert

### Disassembly of Contacts from Insert

A small screwdriver is needed to remove the contacts from the insert.

- Release the white ring by a screwdriver out of the insert
- Move the misplaced contacts out of the insert
- Enter the ring back into the insert
- Push the contacts back into insert

### Shielding

- Assemble strain relief insert with insert
- Fold stranding of the shield back over the first O-Ring of the strain relief insert
- Cut back the overextending braid

 The stranding of the shield is not allowed to touch the second O-Ring. Otherwise the assembly may not be proof.



## M 23 Fast Ethernet PoE



Housings

page 44



Inserts

page 46



Accessories

page 51



## M 23 Fast Ethernet PoE Connectors

Mechanical Data	Materials and Technical Data
Housing	Copper-Zinc alloy Die Casting
Housing surface	Nickel plated
Inserts (for contacts)	PBT UL-94 V0, PA6
Contacts	Brass Alloy
Contact surface at point of contact	Nickel and gold plated (0,25µm Au)
Minimum mating cycles	> 1000
Seals / O-Rings	Perbunan NBR (Standard)
Temperature range	-40° C – 125° C (-40 °F – 257 °F)
Type of contacts	Crimp, dip-solder (PCB)
Protection	IP 67 per EN 60 529 (connected), NEMA 4x
Cable diameter range	11 – 17 mm (.43" – .67")

Electrical Data		
Number of positions	20 (4x2 + 12)	
Number of contacts	4x2	12
ContactØ [mm]	0,6	1
AWG [mm <sup>2</sup> ]	0,08 – 0,34	0,14 – 1 / 1,5
Nominal current <sup>1)</sup> [A]	2	8 <sup>1)</sup>
Nominal voltage <sup>2)</sup> [V~] degree of protection 2 <sup>4)</sup>	160	320
Nominal voltage <sup>2)</sup> [V~] degree of protection 3 <sup>4)</sup>	60	160
Test voltage (Breakdown voltage) <sup>3)</sup> [V~]	500	1500
Insulation resistance [MΩ]	> 10 <sup>6</sup>	> 10 <sup>6</sup>
Max. contact resistance [mΩ]	3	3
Impedance [Ω] (at 100MHz)	100	-

<sup>1), 2), 3), 4)</sup> See Technical Information page 14 <sup>1)</sup> for single contacts even 10 A possible

## M23 Fast Ethernet PoE Connectors / Housing



Straight Female Connector	Cable-Ø	Part Number
	11-17 mm (.43 – .67")	.....7.108.600.000
	Inserts page 46 • Assembly instructions page 48	

Straight Connector, Male Thread	Cable-Ø	Part Number
	11-17 mm (.43 – .67")	.....7.208.600.000
	Inserts page 46 • Assembly instructions page 48	

Right Angle Connector, Female Thread	Type	Part Number
	11-17 mm (.43 – .67")	.....7.308.600.000
	Inserts page 46 • Assembly instructions page 50	



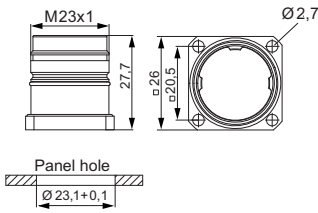

Panel Connector, Male Thread, Front Mounting	Type	Part Number
	4 x holes Ø 2,7 mm (.11") Flange 26 x 26 mm	...7.408.000.000
	Inserts page 46 • Assembly instructions page 49	

## M 23 Fast Ethernet PoE Connectors / Housing

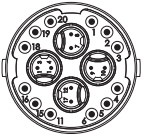
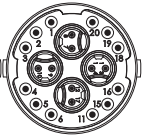
Type	Part Number	Panel Connector, Rear Mounting
4 x holes $\varnothing$ 2,7 mm (.11") ..7.468.000.000 Flange 26 x 26 mm	 <p>Panel hole  <math>\varnothing</math> 23,1+0,1</p>	
Inserts page 46 • Assembly instructions page 49		

## M23 Fast Ethernet PoE Connectors / Inserts / Pinouts / Contacts

Inserts (4 x 2) + 12	Type	Part Number	Part Number
 <p>Insert pin mating view</p>		<b>Pins</b>	<b>Sockets</b>
	Insert		
	without contacts .....	7.003.920.101 .....	7.003.920.102
	Insert with dip solder contacts ....	7.001.920.107 .....	7.001.920.108
 <p>Insert socket mating view</p>	<b>Required Contacts</b>		
	8 x 0,6 .....	7.010.980.641 .....	7.010.980.602
	12 x 1 .....	7.010.901.045 .....	7.010.901.002
		7.010.901.049	7.010.901.012
			7.010.901.022
			7.010.901.046

Contacts	Type	Part Number	Part Number
	Crimp pin 0,6 mm, machined....	0,08 – 0,34 mm <sup>2</sup> .....	7.010.980.641
	Crimp socket 0,6 mm, machined....	0,08 – 0,34 mm <sup>2</sup> .....	7.010.980.602
	Crimp pin 1 mm, machined.....	0,14 – 1 mm <sup>2</sup> .....	7.010.901.049
		0,75 – 1,5 mm <sup>2</sup> .....	7.010.901.045
	Crimp socket 1 mm, machined...	0,08 – 0,56 mm <sup>2</sup> .....	7.010.901.012
		0,34 – 1 mm <sup>2</sup> .....	7.010.901.002
		0,75 – 1,5 mm <sup>2</sup> .....	7.010.901.022
		1 – 1,75 mm <sup>2</sup> .....	7.010.901.046

Please see assembly instructions on page 47

## Crimp Tool Settings for crimp contacts M23 Fast Ethernet PoE

### Crimp Tool Settings for HUMMEL Crimp Contacts (Crimp Tool 7.000.900.907)

Part Number	Crimp Contact	Cross Section (mm <sup>2</sup> )	AWG	Crimp Tool Setting mm	Locator Setting
7.010.980.641	Crimp pin 0,6 mm (0,08 – 0,34 mm <sup>2</sup> )	0,08	AWG 28	0,57	B 1
		0,14	AWG 26	0,60	
		0,25	AWG 24	0,64	
		0,34	AWG 22	0,73	
7.010.980.602	Crimp socket 0,6 mm (0,08 – 0,34 mm <sup>2</sup> )	0,08	AWG 28	0,57	B 2
		0,14	AWG 26	0,60	
		0,25	AWG 24	0,64	
		0,34	AWG 22	0,73	
7.010.901.049	Crimp pin 1 mm (0,14 – 1,0 mm <sup>2</sup> )	0,14	AWG 26	0,70	B 3
		0,25	AWG 24	0,76	
		0,34	AWG 22	0,82	
		0,56	AWG 20	0,90	
		0,75	AWG 18	1,00	
		1,00	AWG 17	1,10	
7.010.901.045	Crimp pin 1 mm (0,75 – 1,5 mm <sup>2</sup> )	0,75	AWG 18	0,80	B 3
		1,00	AWG 17	0,85	
		1,50	AWG 16	0,95	
7.010.901.012	Crimp socket 1 mm (0,08 – 0,56 mm <sup>2</sup> )	0,08	AWG 28	0,75	B 4
		0,14	AWG 26	0,78	
		0,25	AWG 24	0,82	
		0,34	AWG 22	0,88	
		0,56	AWG 20	0,90	
7.010.901.002	Crimp socket 1 mm (0,34– 1,0 mm <sup>2</sup> )	0,34	AWG 22	0,77	B 4
		0,56	AWG 20	0,82	
		0,75	AWG 18	0,88	
		1,00	AWG 17	0,95	
7.010.901.022	Crimp socket 1 mm (0,75 – 1,5 mm <sup>2</sup> )	0,75	AWG 18	0,80	B 4
		1,00	AWG 17	0,86	
		1,50	AWG 16	0,95	
7.010.901.046	Crimp socket 1 mm (1 – 1,75 mm <sup>2</sup> )	1,00	AWG 17	0,85	B 4
		1,50	AWG 16	0,95	
		1,75	AWG 15	1,00	

These values are only guidelines and actual conductor cross sections depend on manufacturer tolerances.

# M23 Fast Ethernet PoE Connectors / Assembly Instructions

## Straight Connector Male / Female Thread

**1.** Pins = 41 mm  
Sockets = 37 mm

**2.** Pins = 7 mm  
Sockets = 0 mm

**3.** Pins = 10 mm  
Sockets = 7 mm

**4.** Crimp

**5.** Crimp

**6.** Crimp

**7.** click

**8.** click

**9.** Crimp

7.000.900.906

**10.** Code + Position

**11.** Code

**12.** click

**13.** click

**14.** Code

**15.**

**16.** 27 24



# M 23 Fast Ethernet PoE Connectors / Assembly Instructions

## Panel Connector

1.  $x$  Pins = 10 mm  
Sockets = 7 mm  
max. 4,5mm

2. max. 4mm

3. Crimp

4. Crimp

5. click

6. click  
Code

7. Crimp  
7.000.900.906

8. Code + Position

9. Code

10. click

11. click  
Code

12.

Code  
Position

# M23 Fast Ethernet PoE Connectors / Assembly Instructions

## Right Angle Connector

1.

2.

3. 

x	Pins = 7 mm Sockets = 0 mm
y	Pins = 10 mm Sockets = 7 mm

4.

5. Crimp

6. Crimp

7. click

8. click

9. Crimp  
7.000.900.906

10. Code + Position

11. Code

12. Code

13. click

14. Code

15. 27

16. 27

17. 27 24

**Diagram 1:** Shows a circular connector with 8 pins. The pins are labeled with positions: 1, 2, 3, 4, 5, 6, 7, 8. The positions are also labeled as Code and Position.

## M 23 Fast Ethernet PoE Connectors / Accessories

Type	Part Number	Accessories
Plastic protective cap for connectors with male thread .....	.....7.000.900.101 for connectors with female thread .....7.000.900.102	
Brass protective cap for connectors with female thread .....	.....7.010.900.183	
Brass protective cap with chain for connectors with female thread	.....Length 70 mm .....7.010.9S0.783 .....Length 100 mm .....7.010.9S1.083	
Brass protective cap for connectors with male thread .....	.....7.010.900.102	
Brass protective cap with chain for connectors with male thread	.....Length 70 mm .....7.010.9S0.702 .....Length 100 mm .....7.010.9S1.002	
Conduit adaptor	Snapflex 16 .....7.010.900.204 DN 12 .....7.010.900.205 Snapflex 20 .....7.010.900.206 DN 14 .....7.010.900.207 Snapflex 25 .....7.010.900.208 DN 17 .....7.010.900.209	
Adaptor flange for Straight Connectors .....	.....7.010.900.128	

## M23 Fast Ethernet PoE Connectors / Accessories

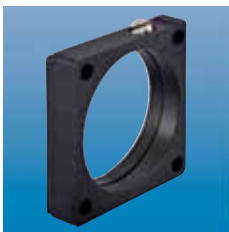
Accessories	Type	Part Number
	Adapter flange for moulded connectors .....	7.010.900.139
	Multi-Bus adapter wired through I:I (excentric)	
	Multi-Bus I, Female Thread, Sockets 17pole	
	Multi-Bus II, Male Thread, Pins .....	7.010.900.143
	Multi-Bus I, Female Thread, Pins, 17pole	
	Multi-Bus II, Male Thread, Sockets .....	7.010.900.144
	Control Cabinet adapter for Multibus II - AIDA	
	Rear Mounting, central locking .....	7.010.900.145
	I/O adapter module to scan or feed signals	
	Rear Mounting, central locking .....	7.010.900.146
	Manual Crimp tool for EMC sleeves M23 Fast Ethernet PoE ...	7.000.900.906
	Manual Crimp tool for turned contacts	
	M23 Fast Ethernet PoE .....	7.000.900.907

## Connectors M 23 RJ 45



Housings

page 56



Accessories

page 59





## M 23 RJ45 Control Signal Connectors

Technical Data	Materials and Technical Data
Housing	Brass Alloy, Die Cast
Housing Surface	Nickel Plated
Inserts (for contacts)	PBT UL-94 V0, PA 6
Contacts	Brass Alloy
Contact Surface at point of contact	Depends on RJ 45 type used
Seals / O-Rings	NBR / FKM (Viton)
Temperature Range	Depends on RJ 45 type used
Degree of Protection	IP 67 / IP 69K per EN 60529 (mated)
Cable diameter range	3 - 7 / 7 - 12 / 11 - 17mm
Number of Positions	4 / 6 / 8 poles, optional 4 + 2 / 6 + 2 / 8 + 2
Nominal Current <sup>1)</sup> [A]	Depends on RJ 45 type used
Nominal Voltage <sup>2)</sup> [V~]	Depends on RJ 45 type used
Test Voltage [V~]	Depends on RJ 45 type used
Insulation Resistance [MΩ]	Depends on RJ 45 type used
Max. Crossover Resistance [mΩ]	Depends on RJ 45 type used
Max. Data Rate	Depends on RJ 45 type used

<sup>1), 2)</sup> See Technical Information page 14

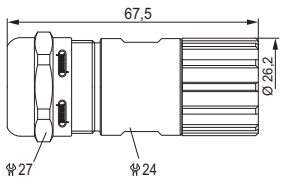
## Connectors M 23RJ45 / Housing

Straight Connector Female Thread		Cable-Ø	Part Number
		3 – 7 mm (.12 - .28") .....	7.R10.400.000
		Connector with insert for patch cable	
		Suitable patch cable can be recommended	
Assembly instructions page 61			

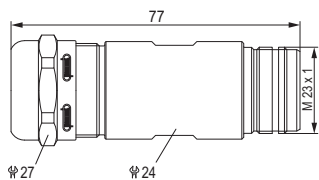
Straight Connector Male Thread		Cable-Ø	Part Number
		3 – 7 mm (.12 - .28") .....	7.R20.408.000
		Incl. 8 poles coupler, fully occupied	
Assembly instructions page 62			

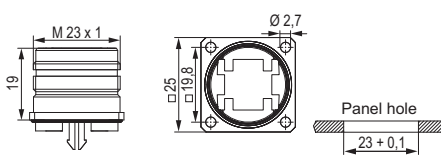
Panel Connector Front Mount, dip solder insert		Type	Part Number
		4 holes 2.7 mm, Flange .....	7.R40.008.000
		Incl. 8 poles dip solder insert	
		4 holes 2.7 mm, Flange .....	7.R40.082.000
		Incl. 8 + 2 poles dip solder insert	

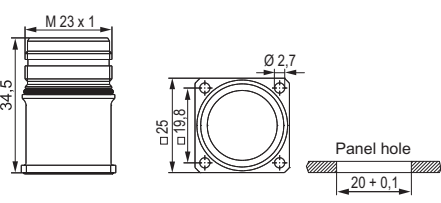
Panel Connector, Front Mount		Type	Part Number
		<b>with vibration protection</b>	
		4 holes 2.7 mm, Flange .....	7.R41.008.000
		Incl. 8 poles coupler, fully occupied	



## Connectors M 23 RJ 45 / Housing

Type	Part Number	Single Hole Panel Connector
<b>Front Mount</b> M20 x 1,5 thread .....7.R42.008.000 Incl. 8 poles coupler, fully occupied  <b>Optional:</b> Gasket M20 x 1,5, Locking Nut		

Type	Part Number	Single Hole Panel Connector
<b>Rear Mount</b> M25 x 1,5 thread .....7.R50.008.000 Incl. 8 poles coupler, fully occupied  M25 x 1,5 Locking Nut included		

Type	Part Number	Right Angle Panel Connector, Male Thread
300° rotating, locking screw at flange 4 holes 2.7 mm, Flange .....7.R43.008.000 Incl. 8 poles coupler, fully occupied  <b>Optional:</b> Gasket  Simple installation with M2.5 screws		

Type	Part Number	Panel Connector Rear Mount, dip solder insert
<b>with vibration protection</b> 4x M3 thread, Flange .....7.R45.008.000 Incl. 8 poles dip solder insert  4x M3 thread, Flange .....7.R45.082.000 Incl. 8 + 2 poles dip solder insert		

## Connectors M 23RJ45 / Housing

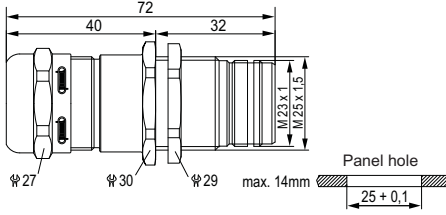
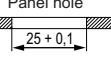
Single Hole Panel Connector with strain relief		Type	Part Number
		<b>Single Hole, RearMount , M25 x 1,5 thread</b> 3 – 7 mm (.12 - .28") .....7.R52.408.000 Incl. 8 poles coupler, fully occupied  M25 x 1,5 Locking Nut included	
			

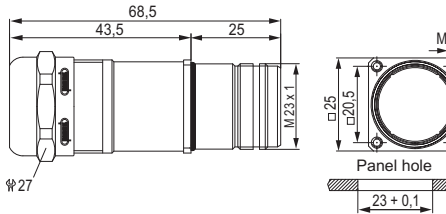
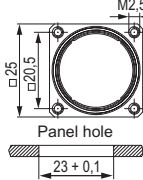
Panel Connector with strain relief		Type	Part Number
		<b>4x M2,5 thread, Flange, Rear Mount</b> 3 – 7 mm (.12 - .28") .....7.R47.408.000 Incl. 8 poles coupler, fully occupied	
			

Type	Part Number	Accessories
Plastic protective cap for connectors with male thread .....7.000.900.101 for connectors with female thread .....7.000.900.102		
Brass protective cap for connectors with female thread .....7.010.900.183		
Brass protective cap for connectors with male thread .....7.010.900.102		
Brass protective cap with chain for connectors with female thread .....Length 70 mm .....7.010.9S0.783 .....Length 100 mm .....7.010.9S1.083		
Brass protective cap with chain for connectors with male thread .....Length 70 mm .....7.010.9S0.702 .....Length 100 mm .....7.010.9S1.002		
Adapter flange for straight connectors .....7.010.900.128		

## Connectors M 23 RJ 45 / Accessories

Accessories	Type	Part Number
	Adapter for Conduit Fittings	Snapflex 16..... 7.010.900.204 DN 12 ..... 7.010.900.205 Snapflex 20..... 7.010.900.206 DN 14 ..... 7.010.900.207 Snapflex 25..... 7.010.900.208 DN 17 ..... 7.010.900.209
	Suitable patch cable .....on request	
	Field attachable RJ45 Connector and Plugs .....on request	

# Connectors M23RJ45 / Assembly Instructions

## Straight Connector, Female Thread

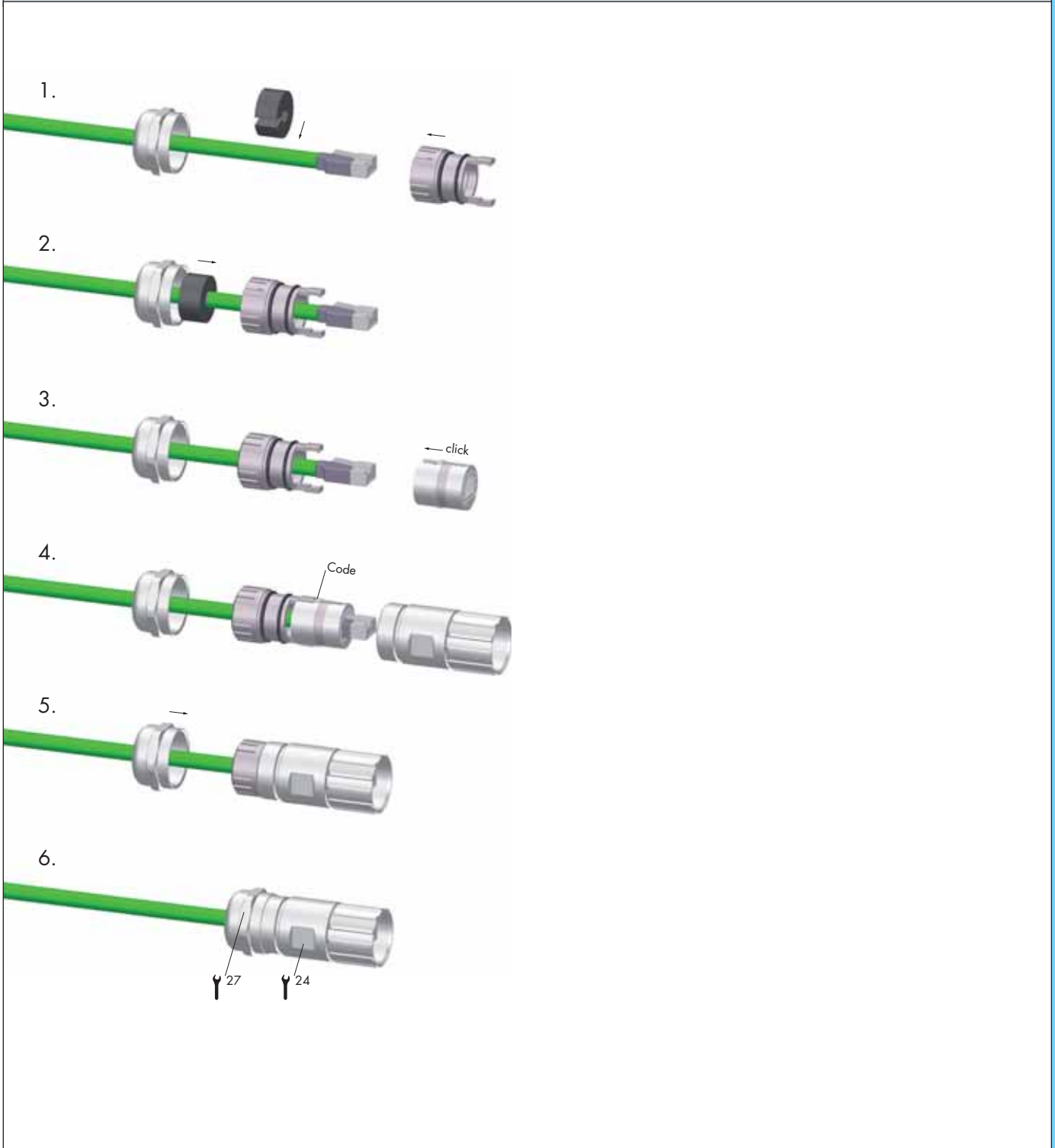

## Male Threaded Connector

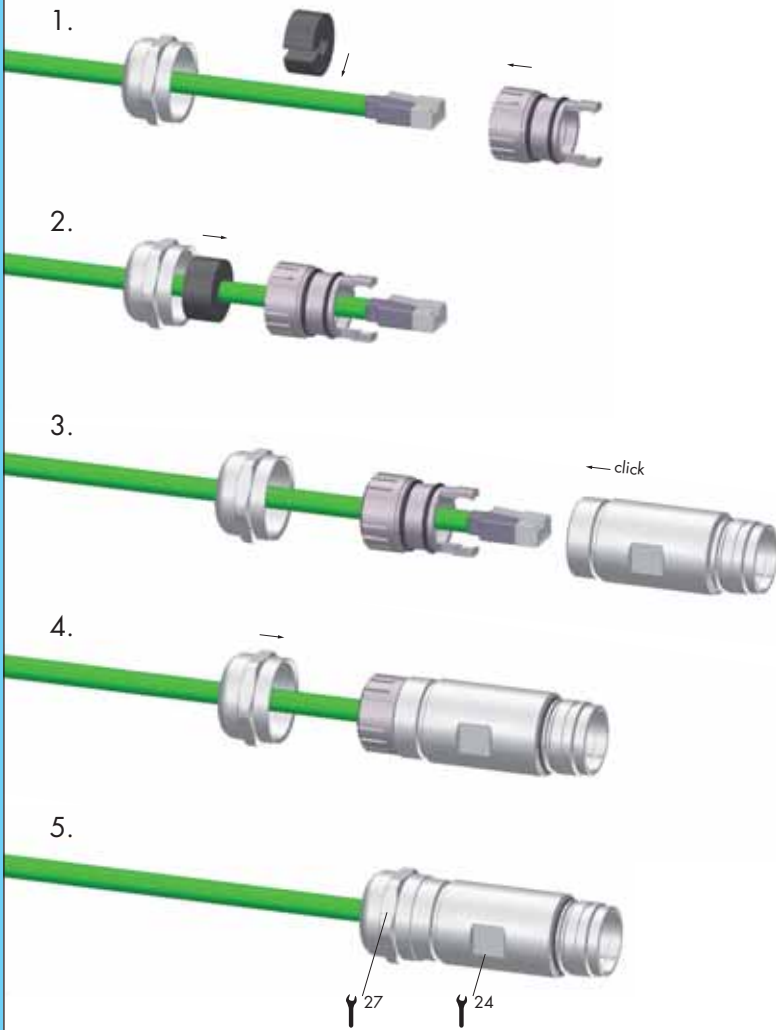

## Signal Connectors M 23



Housings

page 66



Inserts

page 74

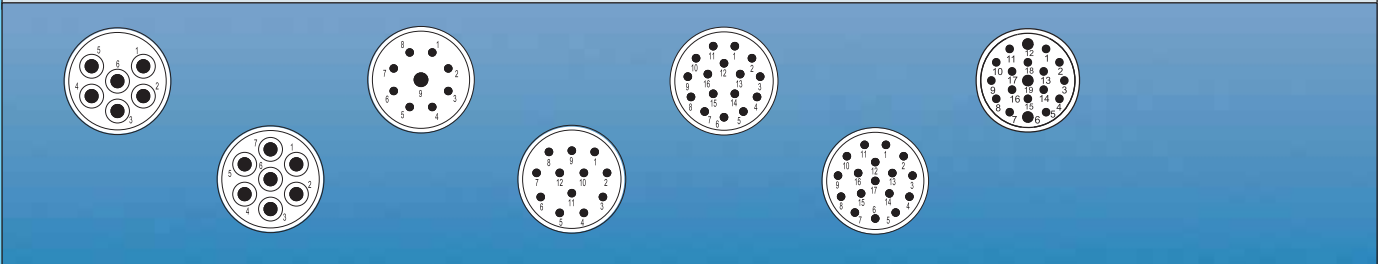

Accessories

page 82

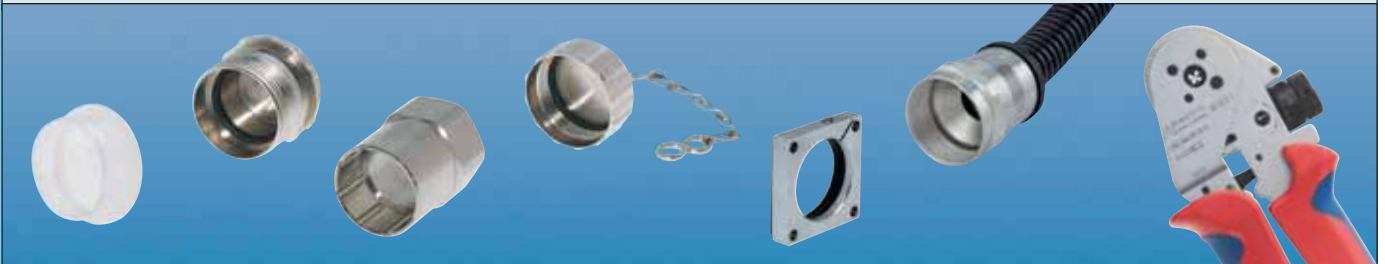



## M 23 Signal Connectors

Mechanical Data	Materials and Technical Data
Housing	Copper-Zinc alloy Die Casting
Housing surface	Nickel plated other surface upon request
Inserts (for contacts)	Thermoplastic Polyamid PA 6 (Nylon 6/6), PBT Fire protection class V-0
Contacts	Brass Alloy
Contact surface at point of contact	Nickel and gold plated (0,25µm Au)
Minimum mating cycles	> 1000
Seals / O-Rings	Buna-N standard optional Viton® (Viton is a registered trademark of DuPont)
Temperature range	-40° C – 125° C (-40 °F – 257 °F)
Type of contacts	Crimp, solder, dip-solder (PCB)
Protection	IP 67 / IP 69K per EN 60 529 (connected), NEMA 4x
Cable diameter range	3 – 17 mm (.12 – .55")

Electrical Data							
Number of positions	6	7	9 (8+1)	12	16	17	19 (16+3)
Number of contacts	6	7	8 1	12	16	17	16 3
ContactØ [mm]	2	2	1 2	1	1	1	1 1,5
Nominal current <sup>1)</sup> [A]	20	20	8 20	8	8	8	8 10
Nominal voltage <sup>2)</sup> [V~] Degree of Protection 2 <sup>3)</sup>	630	630	500	500	400	400	320
Nominal voltage <sup>2)</sup> [V~] Degree of Protection 3 <sup>3)</sup>	300	300	200	200	160	160	100
Test voltage (Breakdown voltage) <sup>4)</sup> [V~]	2500	2500	2500	2500	1500	1500	1500
Insulation resistance [mΩ]	> 10 <sup>10</sup>	> 10 <sup>10</sup>	> 10 <sup>10</sup>	> 10 <sup>10</sup>	> 10 <sup>6</sup>	> 10 <sup>6</sup>	> 10 <sup>6</sup>
Max. contact resistance [mΩ]	3	3	3	3	3	3	3

<sup>1), 2), 3), 4)</sup> See Technical Informations page 14

## Signal Connectors M 23 / Housing

### Straight Connector, Female Thread

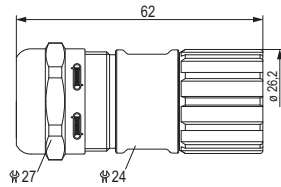

#### Cable-Ø

#### Part Number

3 – 7 mm (.12 – .28")	7.106.400.000
7 – 12 mm (.28 – .47")	7.106.500.000
11 – 17 mm (.44 – .67")	7.106.600.000

Contacts and inserts page 74 • Assembly instructions page 87

### Straight Connector, Male Thread

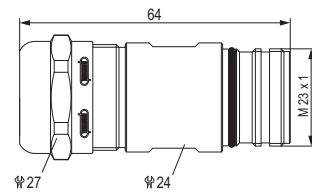

#### Cable-Ø

#### Part Number

3 – 7 mm (.12 – .28")	7.206.400.000
7 – 12 mm (.28 – .47")	7.206.500.000
11 – 17 mm (.44 – .67")	7.206.600.000

Contacts and inserts page 74 • Assembly instructions page 87

### Panel Connector, Male Thread, with Strain Relief

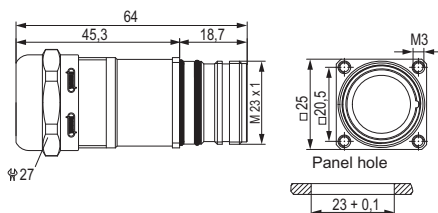

#### Cable-Ø

#### Part Number

<b>4 threads M 3, rear mounting</b>	
3 – 7 mm (.12 – .28")	7.476.400.000
7 – 12 mm (.28 – .47")	7.476.500.000
11 – 17 mm (.44 – .67")	7.476.600.000

**Optional:** Flat gasket

Contacts and inserts page 74 • Assembly instructions page 87

### Panel Connector, Male Thread, with Strain Relief

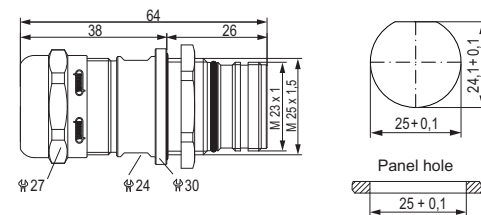

#### Cable-Ø

#### Part Number

<b>Rear mounting, M 25 x 1,5 single hole mounted</b>	
3 – 7 mm (.12 – .28")	7.486.400.000
7 – 12 mm (.28 – .47")	7.486.500.000
11 – 17 mm (.44 – .67")	7.486.600.000

Including jam nut M 25 x 1,5

Contacts and inserts page 74 • Assembly instructions page 87

## Signal Connectors M 23 / Housing

Cable-Ø	Part Number	Right Angle Connector, Female Thread
3 – 7 mm (.12 – .28")	7.300.300.000	
5 – 10 mm (.20 – .39")	7.300.400.000	
7 – 12 mm (.28 – .47")	7.300.500.000	
10 – 14 mm (.39 – .55")	7.300.600.000	
Contacts and inserts page 74 • Assembly instructions page 88		

Cable-Ø	Part Number	Right Angle Connector, Female Thread, EMC
7 – 12 mm (.28 – .47")	7.301.500.000	
10 – 14 mm (.39 – .55")	7.301.600.000	
Contacts and inserts page 74 • Assembly instructions page 88		

Cable-Ø	Part Number	Right Angle Connector with positioning, EMC
7 – 12 mm (.28 – .47")	7.306.500.000	
11 – 17 mm (.43 – .67")	7.306.600.000	
Contacts and inserts page 74 • Assembly instructions page 89		

Cable-Ø	Part Number	Right Angle Connector, Male Thread
3 – 7 mm (.12 – .28")	7.350.300.000	
5 – 10 mm (.20 – .39")	7.350.400.000	
7 – 12 mm (.28 – .47")	7.350.500.000	
10 – 14 mm (.39 – .55")	7.350.600.000	
Contacts and inserts page 74 • Assembly instructions page 88		

## Signal Connectors M 23 / Housing

Panel Connector, Male Thread, Front Mounting		Type	Part Number
		4 holes $\varnothing$ 3,2 mm (.13")	7.400.000.000
		4 threads M 3	7.402.000.000
		4 holes $\varnothing$ 2,7 mm (.11")	7.404.000.000
		4 threads M 2,5	7.406.000.000
		<b>Optional:</b> Flat gasket	
Contacts and inserts page 74 • Assembly instructions page 91 / 92			

Panel Connector, Male Thread, Front Mounting		Type	Part Number
		<b>With anti-vibration O-Ring</b>	
		4 holes $\varnothing$ 3,2 mm (.13")	7.410.000.000
		4 threads M 3	7.412.000.000
		4 holes $\varnothing$ 2,7 mm (.11")	7.414.000.000
		4 threads M 2,5	7.416.000.000
		<b>Optional:</b> Flat gasket	
Contacts and inserts page 74 • Assembly instructions page 91 / 92			

Panel Connector, Female Thread, with knurled Nut		Type	Part Number
		<b>Without coding option</b>	
		4 holes $\varnothing$ 3,2 mm (.13")	7.440.000.000
		4 holes $\varnothing$ 2,7 mm (.11")	7.444.000.000
		<b>Optional:</b> Flat gasket	
Contacts and inserts page 74 • Assembly instructions page 90			

Panel Connector, Female Thread, with knurled Nut		Type	Part Number
		<b>With coding option (8 x 45°)</b>	
		4 holes $\varnothing$ 3,2 mm (.13")	7.448.000.000
		4 holes $\varnothing$ 2,7 mm (.11")	7.449.000.000
		<b>Optional:</b> Flat gasket	
Contacts and inserts page 74 • Assembly instructions page 90			

## Signal Connectors M 23/Housing

Type	Part Number	Panel Connector, Male Thread, Single Hole Mounted	
<b>Front mounting for male inserts</b> Thread M 20 x 1,5 .....7.420.000.000 Thread PG 13,5 .....7.422.000.000  <b>Optional:</b> Flat gasket, jam nut M 20 x 1,5 / PG 13,5			
Contacts and inserts page 74 • Assembly instructions page 91			

Type	Part Number	Panel Connector, Male Thread, Single Hole Mounted	
<b>Front mounting for female inserts</b> Thread M 20 x 1,5 .....7.421.000.000 Thread PG 13,5 .....7.423.000.000  <b>Optional:</b> Flat gasket, jam nut M 20 x 1,5 / PG 13,5			
Contacts and inserts page 74 • Assembly instructions page 92			

Type	Part Number	Panel Connector, Male Thread, Single Hole Mounted	
<b>For insert with pins / sockets</b> Thread M 25 x 1,5 .....7.425.000.000  <b>Optional:</b> Flat gasket, jam nut M 25 x 1,5			
Contacts and inserts page 74 • Assembly instructions page 91 / 92			

Right Angle Panel Connector, Male Thread		Type	Part Number
		4 holes 2,7 mm (.11").....	7.435.000.000
		<b>Optional:</b> Flat gasket  Easy fixation with M2,5 screws  Contacts and inserts page 74 • Assembly instructions page 93	

Right Angle Panel Connector, Male Thread, rotatable		Type	Part Number
		<b>335° rotating, hole mounted</b>	Thread M 20 x 1,5 .....
		7.431.000.000  Contacts and inserts page 74 • Assembly instructions page 93	

Right Angle Panel Connector, Male Thread, rotatable		Type	Part Number
		<b>335° rotating, hole mounted</b>	Thread PG 13,5 .....
		7.432.000.000  Contacts and inserts page 74 • Assembly instructions page 93	

Right Angle Panel Connector, Male Thread, rotatable		Type	Part Number
		<b>300° rotating, 1,5 mm locking screw at flange</b>	4 x holes Ø 2,7 mm (.11") ..
		7.433.000.000 Flange 25 x 25 mm  4 x holes Ø 3,2 mm..... 7.433.100.000 Flange 28 x 28 mm  Contacts and inserts page 74 • Assembly instructions page 93	

## Signal Connectors M 23 / Housing

Type	Part Number	Panel Connector, Male Thread, Rear Mounting	
4 holes $\varnothing$ 3,2 mm (.13")	.....7.450.000.000		
4 threads M 3	.....7.452.000.000		
4 holes $\varnothing$ 2,7 mm (.11")	.....7.454.000.000		
4 threads M 2,5	.....7.456.000.000		
<b>Optional:</b> Flat gasket			
Contacts and inserts page 74 • Assembly instructions page 91 / 92			

Type	Part Number	Panel Connector, Male Thread, Rear Mounting	
<b>With anti-vibration O-Ring</b>			
4 holes $\varnothing$ 3,2 mm (.13")	.....7.460.000.000		
4 threads M 3	.....7.462.000.000		
4 holes $\varnothing$ 2,7 mm (.11")	.....7.464.000.000		
4 threads M 2,5	.....7.466.000.000		
<b>Optional:</b> Flat gasket			
Contacts and inserts page 74 • Assembly instructions page 91 / 92			

Type	Part Number	Panel Connector, Male Thread, Single Hole Mounted	
<b>Rear mounting</b>			
Thread M 25 x 1,5	.....7.458.000.000		
Including jam nut M 25 x 1,5			
Contacts and inserts page 74 • Assembly instructions page 91 / 92			

Type	Part Number	Panel Connector, Female Thread, Rear Mounting	
<b>With knurled nut, rear mounting</b>			
4 threads M 3	.....7.459.000.000		
Contacts and inserts page 74 • Assembly instructions page 90			

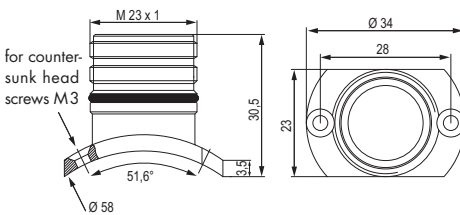
Panel Connector with Radius Flange		Type	Part Number
	 <p>for counter-sunk head screws M3</p>	<b>With anti-vibration O-Ring and flat body gasket</b> Ø 58 mm (2.28") .....7.490.000.000	
		Contacts and inserts page 74 • Assembly instructions page 91 / 92	

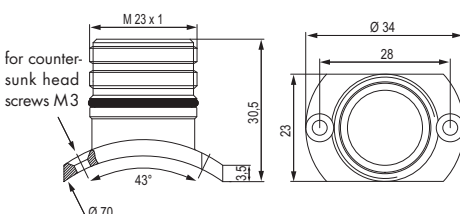
Panel Connector with Radius Flange		Type	Part Number
	 <p>for counter-sunk head screws M3</p>	<b>With anti-vibration O-Ring and flat body gasket</b> Ø 70 mm (2.76") .....7.491.000.000	
		Contacts and inserts page 74 • Assembly instructions page 91 / 92	

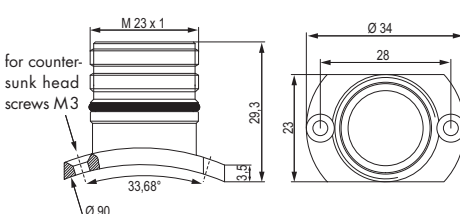
Panel Connector with Radius Flange		Type	Part Number
	 <p>for counter-sunk head screws M3</p>	<b>With anti-vibration O-Ring and flat body gasket</b> Ø 90 mm (3.54") .....7.492.000.000	
		Contacts and inserts page 74 • Assembly instructions page 91 / 92	

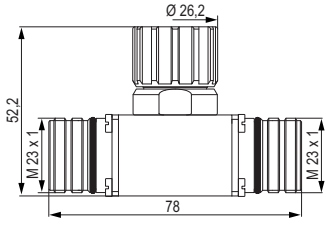

## Signal Connectors M 23 / Housing

Type	Part Number	Signal Distribution
T 01	7.T01	
<p>Contacts and inserts page 74</p> 		

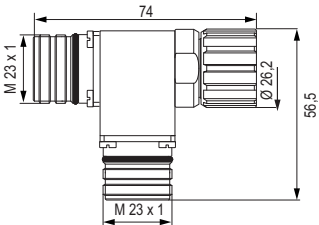
Type	Part Number	Signal Distribution
T 02	7.T02	
<p>Contacts and inserts page 74</p> 		

Signal Distribution
<p>In case of so called Flying Connections it is often required to distribute, cross or combine signals. Depending on the requirements of the application, the connections can be supplied either as male or female connector, or they can be configured with strain relief fittings. There are many possible combinations, including the internal wiring, independent of their style, as T-, Y-, H-, or other special configurations.</p> 

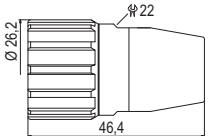
Type	Part Number	Bus End Connector
Closed type	7.105.000.000	
<p>Used to cap an open male connector in bus-systems</p> 		
<p>Contacts and inserts page 74</p>		

## Signal Connectors M 23 / Inserts / Pinouts

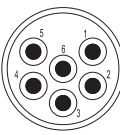
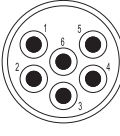
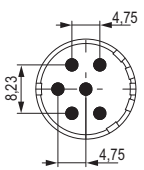
Inserts 6-pole	Type	Part Number	Part Number
 <p>Insert pin mating view (Part E)</p>  <p>Insert socket mating view (Part P)</p> 	<b>Pinout clockwise</b>	<b>Pins</b>	<b>Sockets</b>
	Insert with solder contacts .....	7.001.906.103 .....	7.001.906.104
	Insert without contacts .....	7.003.906.101 .....	7.003.906.102
	Insert with dip solder contacts		
	Length 3,5 mm .....	7.001.906.107	
	Insert with dip solder contacts		
	Length 10 mm .....	7.001.906.127 .....	7.001.906.108
	Insert with dip solder contacts		
	Length 17 mm .....	7.001.906.137 .....	7.001.906.118
	<b>The correct dimension of a connector with dip solder contacts depends on the particular type of housing.</b>		
Contacts page 80 • Coding possibilities N, S, H, X and Y (see page 79)			

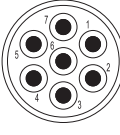
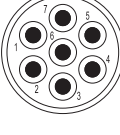
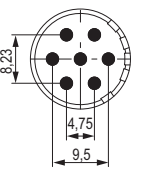
Inserts 7-pole	Type	Part Number	Part Number
 <p>Insert pin mating view (Part E)</p>  <p>Insert socket mating view (Part P)</p> 	<b>Pinout clockwise</b>	<b>Pins</b>	<b>Sockets</b>
	Insert with solder contacts .....	7.001.907.103 .....	7.001.907.104
	Insert without contacts .....	7.003.907.101 .....	7.003.907.102
	Insert with dip solder contacts		
	Length 3,5 mm .....	7.001.907.107	
	Insert with dip solder contacts		
	Length 10 mm .....	7.001.907.127 .....	7.001.907.108
	Insert with dip solder contacts		
	Length 17 mm .....	7.001.907.137 .....	7.001.907.118
	<b>The correct dimension of a connector with dip solder contacts depends on the particular type of housing.</b>		
Contacts page 80 • Coding possibilities N, S, H, X and Y (see page 79)			

## Signal Connectors M 23 / Inserts / Pinouts

Type	Part Number	Part Number	Inserts 9-pole (8 + 1)
<b>Pinout clockwise</b>	<b>Pins</b>	<b>Sockets</b>	
Insert with solder contacts .....	7.001.981.103 .....	7.001.981.104 .....	<p>Insert pin mating view (Part E)</p>
Insert without contacts .....	7.003.981.101 .....	7.003.981.102 .....	
Insert with dip solder contacts Length 3,5 mm .....	7.001.981.107 .....		<p>Insert socket mating view (Part P)</p>
Insert with dip solder contacts Length 10 mm .....	7.001.981.127 .....	7.001.981.108 .....	
Insert with dip solder contacts Length 17 mm .....	7.001.981.137 .....	7.001.981.118 .....	
<p><b>The correct dimension of a connector with dip solder contacts depends on the particular type of housing.</b></p>			
<p>Contacts page 80 • Coding possibilities N, S, H, X and Y (see page 79)</p>			

Type	Part Number	Part Number	Inserts 9-pole (8 + 1)
<b>Pinout counter-clockwise</b>	<b>Pins</b>	<b>Sockets</b>	
Insert with solder contacts .....	7.002.981.103 .....	7.002.981.104 .....	<p>Insert pin mating view (Part P)</p>
Insert without contacts .....	7.004.981.101 .....	7.004.981.102 .....	
Insert with dip solder contacts Length 3,5 mm .....	7.002.981.107 .....		<p>Insert socket mating view (Part E)</p>
Insert with dip solder contacts Length 10 mm .....	7.002.981.127 .....	7.002.981.108 .....	
Insert with dip solder contacts Length 17 mm .....	7.002.981.137 .....	7.002.981.118 .....	
<p><b>The correct dimension of a connector with dip solder contacts depends on the particular type of housing.</b></p>			
<p>Contacts page 80 • Coding possibilities N, S, H, X and Y (see page 79)</p>			

# Signal Connectors M 23 / Inserts / Pinouts

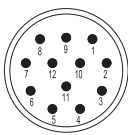
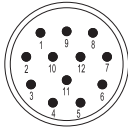
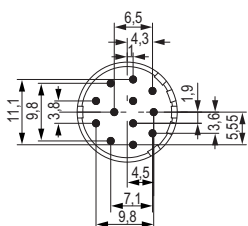
Inserts 12-pole	Type	Part Number	Part Number	
 <p>Insert pin mating view (Part E)</p>  <p>Insert socket mating view (Part P)</p> 	<b>Pinout clockwise</b>	<b>Pins</b>	<b>Sockets</b>	
	Insert with solder contacts	7.001.912.103	7.001.912.104	
	Insert with solder contacts +PE (Pos.9)	7.001.912.113	7.001.912.114	
	Insert without contacts	7.003.912.101	7.003.912.102	
	Insert without contacts +PE (Pos.9)	7.003.912.111	7.003.912.112	
	Insert with dip solder contacts Length 3,5 mm	7.001.912.107		
	Insert with dip solder contacts Length 10 mm	7.001.912.127	7.001.912.108	
	Insert with dip solder contacts Length 17 mm	7.001.912.137	7.001.912.118	
	<b>The correct dimension of a connector with dip solder contacts depends on the particular type of housing.</b>			
	Contacts page 80 • Coding possibilities N, S, H, X and Y (see page 79)			

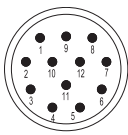
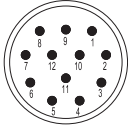
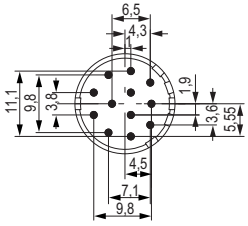
Inserts 12-pole	Type	Part Number	Part Number	
 <p>Insert pin mating view (Part E)</p>  <p>Insert socket mating view (Part P)</p> 	<b>Pinout counter-clockwise</b>	<b>Pins</b>	<b>Sockets</b>	
	Insert with solder contacts	7.002.912.103	7.002.912.104	
	Insert with solder contacts +PE (Pos.9)	7.002.912.113	7.002.912.114	
	Insert without contacts	7.004.912.101	7.004.912.102	
	Insert without contacts +PE (Pos.9)	7.004.912.111	7.004.912.112	
	Insert with dip solder contacts Length 3,5 mm	7.002.912.107		
	Insert with dip solder contacts Length 10 mm	7.002.912.127	7.002.912.108	
	Insert with dip solder contacts Length 17 mm	7.002.912.137	7.002.912.118	
	<b>The correct dimension of a connector with dip solder contacts depends on the particular type of housing.</b>			
	Contacts page 80 • Coding possibilities N, S, H, X and Y (see page 79)			

## Signal Connectors M 23 / Inserts / Pinouts

Type	Part Number	Part Number	Inserts 16-pole
<b>Pinout clockwise</b>	<b>Pins</b>	<b>Sockets</b>	
Insert with solder contacts .....	7.001.916.103 .....	7.001.916.104 .....	<p>Insert pin mating view (Part E)</p>
Insert without contacts .....	7.003.916.101 .....	7.003.916.102 .....	
Insert with dip solder contacts Length 3,5 mm .....	7.001.916.107 .....		<p>Insert socket mating view (Part P)</p>
Insert with dip solder contacts Length 10 mm .....	7.001.916.127 .....	7.001.916.108 .....	
Insert with dip solder contacts Length 17 mm .....	7.001.916.137 .....	7.001.916.118 .....	
<p><b>The correct dimension of a connector with dip solder contacts depends on the particular type of housing.</b></p>			
<p>Contacts page 80 • Coding possibilities N, S, H, X and Y (see page 79)</p>			

Type	Part Number	Part Number	Inserts 17-pole
<b>Pinout clockwise</b>	<b>Pins</b>	<b>Sockets</b>	
Insert with solder contacts .....	7.001.917.103 .....	7.001.917.104 .....	<p>Insert pin mating view (Part E)</p>
Insert without contacts .....	7.003.917.101 .....	7.003.917.102 .....	
Insert with dip solder contacts Length 3,5 mm .....	7.001.917.107 .....		<p>Insert socket mating view (Part P)</p>
Insert with dip solder contacts Length 10 mm .....	7.001.917.127 .....	7.001.917.108 .....	
Insert with dip solder contacts Length 17 mm .....	7.001.917.137 .....	7.001.917.118 .....	
<p><b>The correct dimension of a connector with dip solder contacts depends on the particular type of housing.</b></p>			
<p>Contacts page 80 • Coding possibilities N, S, H, X and Y (see page 79)</p>			

# Signal Connectors M 23 / Inserts / Pinouts

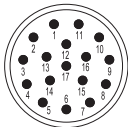
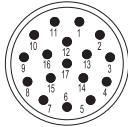
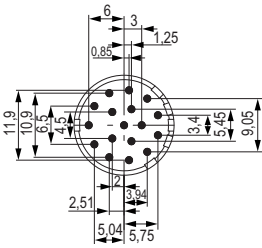
Inserts 17-pole	Type	Part Number	Part Number
 <p>Insert pin mating view (Part P)</p>  <p>Insert socket mating view (Part E)</p> 	<b>Pinout counter-clockwise</b>	<b>Pins</b>	<b>Sockets</b>
	Insert with solder contacts .....	7.002.917.103 .....	7.002.917.104
	Insert without contacts .....	7.004.917.101 .....	7.004.917.102
	Insert with dip solder contacts Length 3,5 mm .....	7.002.917.107	
	Insert with dip solder contacts Length 10 mm .....	7.002.917.127 .....	7.002.917.108
	Insert with dip solder contacts Length 17 mm .....	7.002.917.137 .....	7.002.917.118
	<b>The correct dimension of a connector with dip solder contacts depends on the particular type of housing.</b>		
	Contacts page 80 • Coding possibilities N, S, H, X and Y (see page 79)		

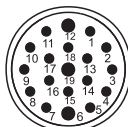
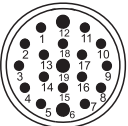
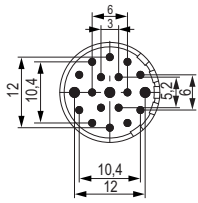
Inserts 19-pole	Type	Part Number	Part Number
 <p>Insert pin mating view (Part E)</p>  <p>Insert socket mating view (Part P)</p> 	<b>Pinout clockwise</b>	<b>Pins</b>	<b>Sockets</b>
	Insert with solder contacts .....	7.001.919.103 .....	7.001.919.104
	Insert with solder contacts +PE (Pos. 12) .....	7.001.919.113 .....	7.001.919.114
	Insert with solder contacts + PE (Pos. 12) 1,5 mm elongated .....	7.001.919.123	
	Insert without contacts .....	7.003.919.101 .....	7.003.919.102
	Insert without contacts +PE (Pos. 12) .....	7.003.919.111 .....	7.003.919.112
	Insert with dip solder contacts Length 3,5 mm .....	7.001.919.107	
	Insert with dip solder contacts Length 10 mm .....	7.001.919.127 .....	7.001.919.108
	Insert with dip solder contacts Length 17 mm .....	7.001.919.137 .....	7.001.919.118
	<b>The correct dimension of a connector with dip solder contacts depends on the particular type of housing.</b>		
Contacts page 80 • Coding possibilities N, S, H, X and Y (see page 79)			

## Signal Connectors M 23 / Required Contacts

Number of Poles	Required Contacts	Contact Arrangement
6 .....	6 x 2 mm	
7 .....	7 x 2 mm	
9 (8 + 1) .....	8 x 1 mm 1 x 2 mm	
12 .....	12 x 1 mm	
16 .....	16 x 1 mm	
17 .....	17 x 1 mm	
19 .....	16 x 1 mm 3 x 1,5 mm	

Crimp contacts page 80

Number of Poles	Coding Possibilities	Coding
6-pole .....	N, S, H, X, Y and Z	<p>Female Inserts mating view</p>
7-pole .....	N, S, H, X and Y	
9-pole .....	N, S, H, X and Y	<p>Male Inserts mating view</p>
12-pole .....	N, S, H, X, Y and Z	
16-pole .....	N, S, H, X, Y and Z	
17-pole .....	N, S, H, X, Y and Z	
19-pole .....	N, S, H, X and Y	

As standard, coding groove N is opened. To use other codings, please remove the coding barrier.

## Signal Connectors M23 / Contacts

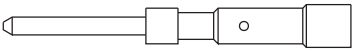
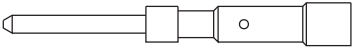
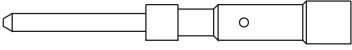
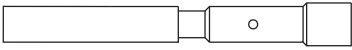
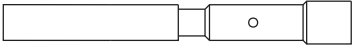
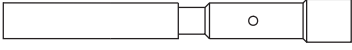
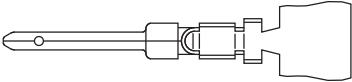
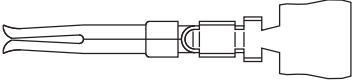
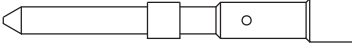

Contacts	Type	Crimp Range	Part Number
	Crimp pin 1 mm, machined	.....0,08 – 0,56 mm <sup>2</sup> (AWG 28 – 20)	7.010.901.031
	Crimp pin 1 mm, machined	.....0,14 – 1 mm <sup>2</sup> (AWG 26 – 17)	.....7.010.901.001
	Crimppin 1 mm, machined	.....1 – 1,5 mm <sup>2</sup> (AWG 17 – 16)	.....7.010.901.021
	Crimp socket 1 mm, machined	...0,08 – 0,56 mm <sup>2</sup> (AWG 28 – 20)	..7.010.901.012
	Crimp socket 1 mm, machined	...0,34 – 1 mm <sup>2</sup> (AWG 22 – 17)	.....7.010.901.002
	Crimp socket 1 mm, machined	...1 – 1,5 mm <sup>2</sup> (AWG 17 – 16)	.....7.010.901.022
	Crimp pin 1 mm, stamped	.....0,14 – 0,56 mm <sup>2</sup> (AWG 26 – 20)	...upon request
	Crimp socket 1 mm, stamped	.....0,14 – 0,56 mm <sup>2</sup> (AWG 26 – 20)	...upon request
	Crimp pin 1,5 mm, machined	...0,14 – 1 mm <sup>2</sup> (AWG 26 – 17)	.....7.010.901.501

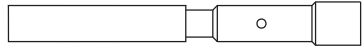
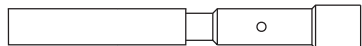
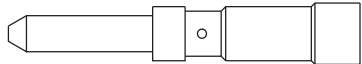
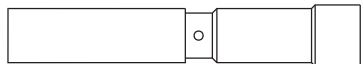

Type	Crimp Range	Part Number	Contacts
Crimp socket 1,5 mm, machined	0,14 – 0,56 mm <sup>2</sup> (AWG 26 – 20)	7.010.901.512	
Crimp socket 1,5 mm, machined	0,56 – 1 mm <sup>2</sup> (AWG 20 – 17)	7.010.901.502	
Crimp pin 2 mm, machined	0,75 – 2,5 mm <sup>2</sup> (AWG 18 – 14)	7.010.902.001	
Crimp socket 2 mm, machined	0,75 – 2,5 mm <sup>2</sup> (AWG 18 – 14)	7.010.902.002	

Crimp Tool Settings see page 86

Accessories	Type	Part Number
	Plastic protective cap for connectors with male thread .....7.000.900.101 for connectors with female thread.....7.000.900.102	
	Brass protective cap for connectors with female thread.....7.010.900.103	
	Brass protective cap for connectors with male thread .....7.010.900.102	
	Brass protective cap with chain for connectors with female thread .....Length 70 mm .....7.010.9S0.703 Length 100 mm .....7.010.9S1.003	
	Brass protective cap with chain for connectors with male thread.....Length 70 mm .....7.010.9S0.702 Length 100 mm .....7.010.9S1.002	
	Assembly tool .....7.010.900.101	

Type	Part Number	Accessories
Crimp tool for manual crimping of machined crimp contacts for signal connectors .....	7.000.900.904	
Operating instructions on page 84 - 86, 94		
Adaptor flange for Straight Connectors .....	7.010.900.128	
Adapter for Conduit Fittings	Snapflex 16.....7.010.900.204 DN 12 .....7.010.900.205 Snapflex 20.....7.010.900.206 DN 14 .....7.010.900.207 Snapflex 25.....7.010.900.208 DN 17 .....7.010.900.209	

Type	Part Number	for HUMMEL Contact	Locator
Locator for Crimp Tool DMC M22520 with positioner ....	7.000.9DM.C03 .....	7.010.901.001, 7.010.901.501, 7.010.902.001	
Locator for Crimp Tool DMC M22520 with positioner ....	7.000.9DM.C04 .....	7.010.901.012, 7.010.901.002, 7.010.901.512, 7.010.901.502, 7.010.902.002	

# Crimp Tool for Signal Connectors M23 / M16

Crimp Tool	Type	Part Number	
	Crimp tool.....	7.000.900.904 / 7.000.900.907	
	<b>Application</b>	The four indent crimp tool 7.000.900.904 / 7.000.900.907 has been developed for optimal crimping of machined contacts with diameters from 0.08 to 2.5 mm <sup>2</sup> (28 through 14 AWG).	
	<b>How to Crimp</b>	The reference table indicates the correct locator position to be selected and the crimp depth to be adjusted for the contact to be crimped. The contact is then inserted through the access hole of the tool on the opposite side of the locator. The contact is held in place by closing the handles to the first lock-in position thus preventing the contact from falling out of the tool and facilitating insertion of the wire into the contact. The precision ratchet assures consistently accurate crimping every time by forcing the tool to be closed all the way completing the crimping cycle before the tool can be opened again.	
	<b>Exchange of the Locator</b>	The locator can be exchanged by removing the socket head cap screw with a socket wrench. It can then be disassembled from the hex head screw by turning it counter-clockwise.	
	Scale indicating 0.2 mm increments  Physical stop		Crimp jaws  Adjusting screw with 0.01 mm increments

## Crimp Tool

### Adjustment of Crimp Depth

Crimp depth can be adjusted as follows:

Turn the adjusting screw clockwise for reducing the crimp depth and counter-clockwise for increasing the crimp depth.

### Adjustment Increments:

- 1 space on the adjusting screw  $\hat{=}$  adjustment by 0.01 mm
- 1 full rotation of adjusting screw  $\hat{=}$  adjustment by 0.2 mm (indication on the screw as well as on the rough scale)
- 5 rotations of the adjusting screw  $\hat{=}$  adjustment by 1 mm (indication on the scale)

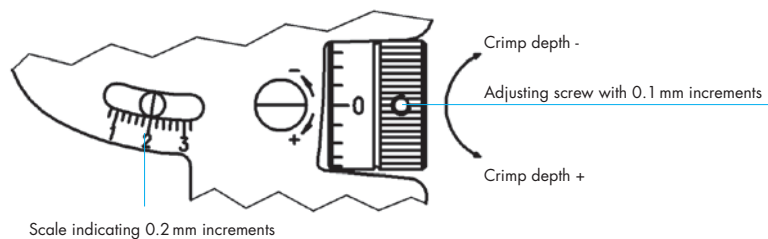

### Control of Crimp Depth

Crimp tool adjustment is done at the factory, but with frequent use, periodic calibration is recommended to insure accuracy. This is easily accomplished with a 1.0 mm  $\varnothing$  wire gauge as follows.

A crimp depth of 1.0 mm is set by means of the adjusting screw (scale mark at „1“, screw mark at „0“ as shown in the fig. above) and the tool in the closed position. After insertion of the gauge, there must be just enough space for moving the gauge inside the entry hole. If the opening is too small or too large to exactly match the gauge, the deviation (+/-) can be checked by the precision setting of the screw. Please contact the factory in case the deviation exceeds the tolerances specified by the contract manufacturer.

### Maintenance and Repair

Keep the tool clean and properly stored when not in service. All pivot points need to be oiled regularly and the spring clips securing the bolts have to always be in place. For repair please send the tool back to the factory.

## Crimp Tool for Signal Connectors M23

### Crimp Tool Setting for HUMMEL Crimp Contacts (Crimp Tool 7.000.900.904)

Part Number	Crimp Contact	Cross Section (mm <sup>2</sup> )	AWG	Crimp Tool Setting mm	Locator Setting
7.010.901.001	Crimp pin 1 mm	0,14	AWG 26	0,70	1
		0,25	AWG 24	0,76	
		0,34	AWG 22	0,82	
		0,50	AWG 20	0,90	
		0,75	AWG 18	1,00	
		1,00	AWG 17	1,10	
7.010.901.012	Crimp socket 1 mm (0,08 – 0,56 mm <sup>2</sup> )	0,08	AWG 28	0,75	2
		0,14	AWG 26	0,78	
		0,25	AWG 24	0,82	
		0,34	AWG 22	0,86	
		0,56	AWG 20	0,90	
7.010.901.002	Crimp socket 1 mm (0,34 – 1 mm <sup>2</sup> )	0,34	AWG 22	0,77	2
		0,56	AWG 20	0,82	
		0,75	AWG 18	0,88	
		1,00	AWG 17	0,95	
7.010.901.501	Crimp pin 1,5 mm	0,14	AWG 26	0,65	3
		0,25	AWG 24	0,68	
		0,34	AWG 22	0,72	
		0,56	AWG 20	0,81	
		0,75	AWG 18	0,95	
		1,00	AWG 17	1,07	
7.010.901.512	Crimp socket 1,5 mm (0,14 – 0,75 mm <sup>2</sup> )	0,14	AWG 26	0,70	2
		0,25	AWG 24	0,73	
		0,34	AWG 22	0,77	
		0,56	AWG 20	0,85	
		0,75	AWG 18	1,05	
7.010.901.502	Crimp socket 1,5 mm (0,34 – 1 mm <sup>2</sup> )	0,34	AWG 22	0,88	2
		0,56	AWG 20	0,95	
		0,75	AWG 18	1,05	
		1,0	AWG 17	1,13	
7.010.902.001	Crimp pin 2 mm	0,75	AWG 18	1,20	4
		1,0	AWG 17	1,35	
		1,5	AWG 16	1,45	
		2,5	AWG 14	1,60	
7.010.902.002	Crimp socket 2 mm	0,75	AWG 18	1,25	5
		1,0	AWG 17	1,35	
		1,5	AWG 16	1,45	
		2,5	AWG 14	1,60	

Assembly information see page 94

# Signal Connectors M23 / Assembly Instructions

## Straight Connector, Male / Female Thread

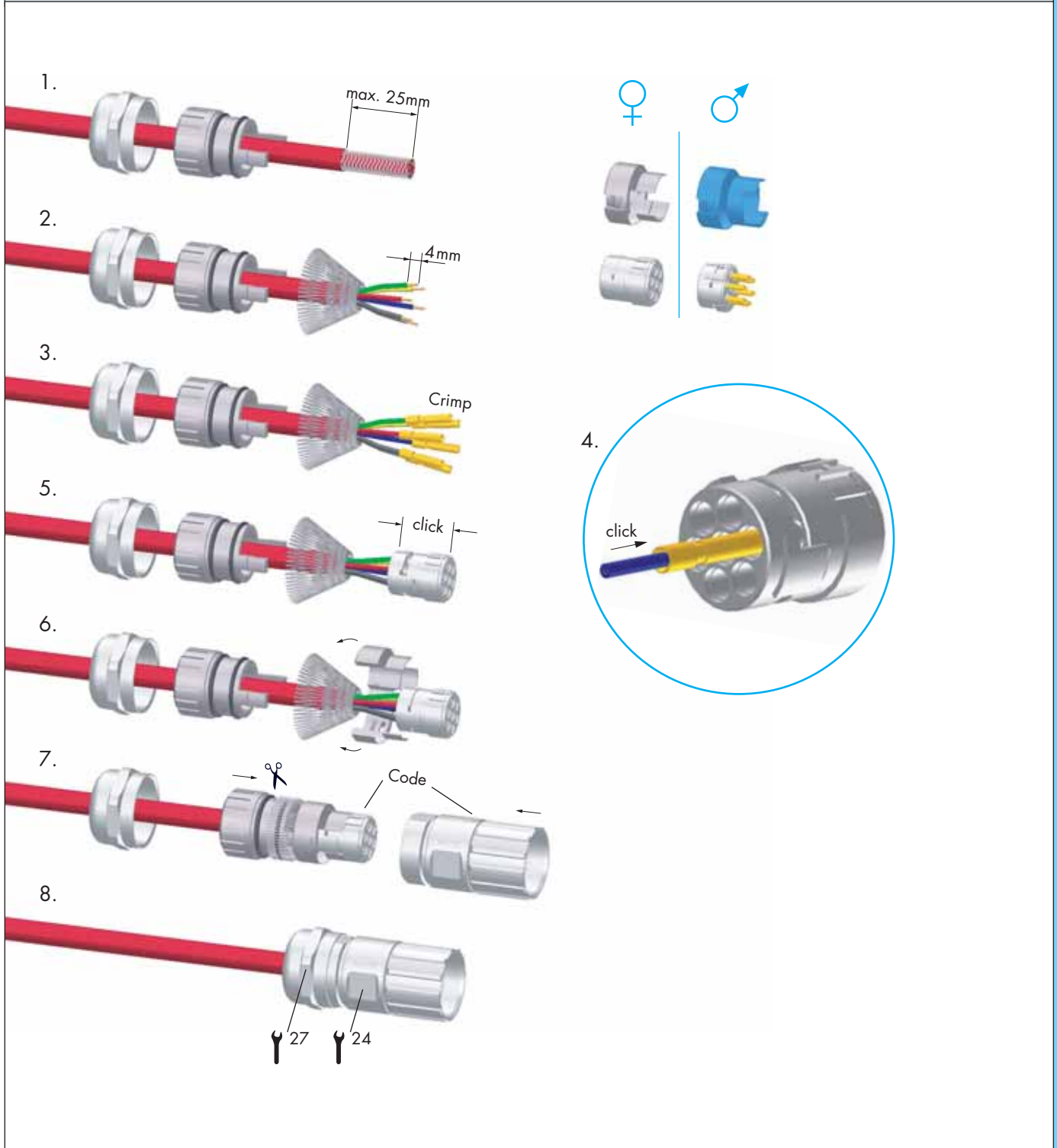

# Signal Connectors M23 / Assembly Instructions

## Right Angle Connectors, EMC

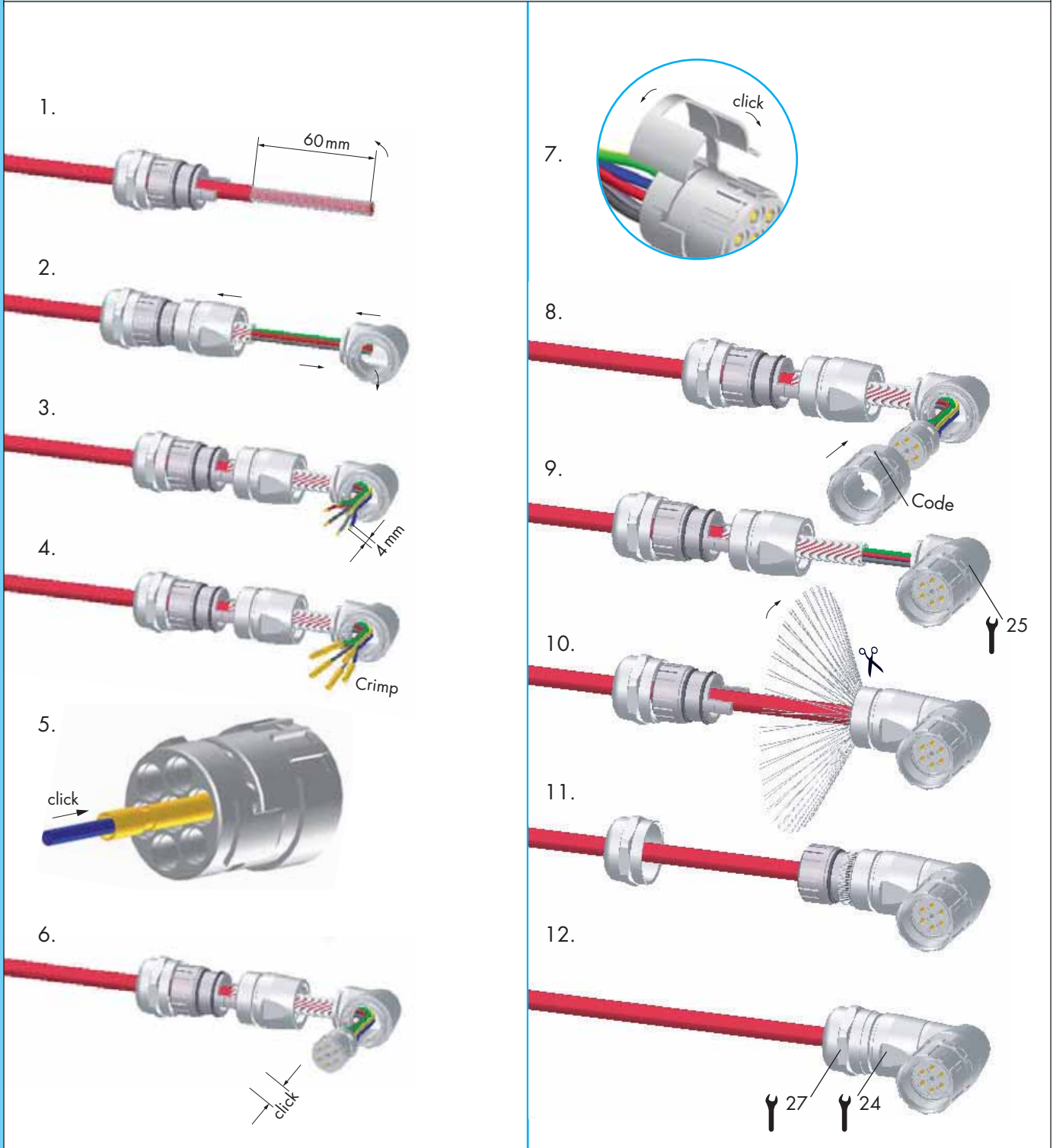







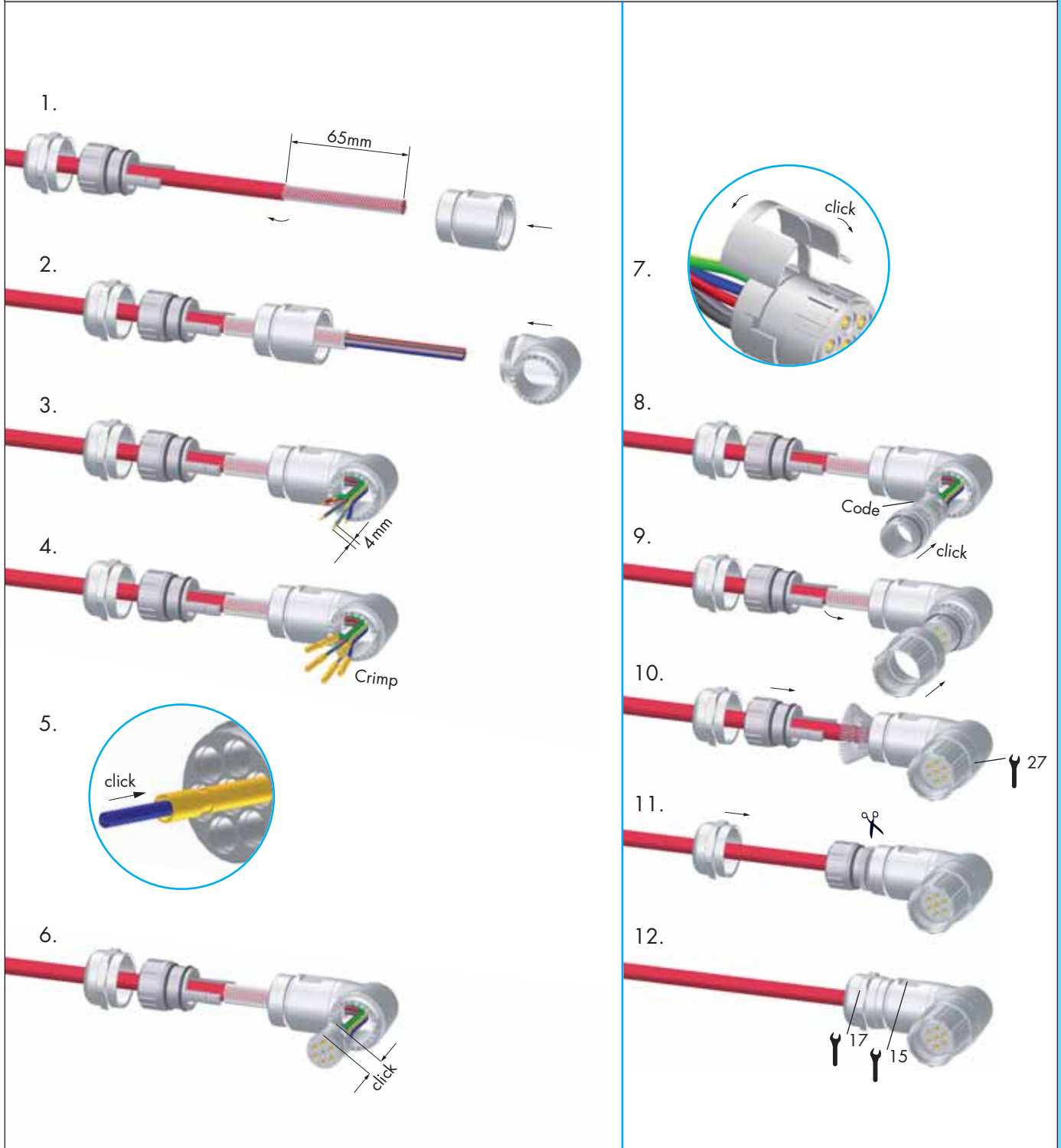

# Signal Connectors M23 / Assembly Instructions

## Right Angle Connector with positioning, EMC

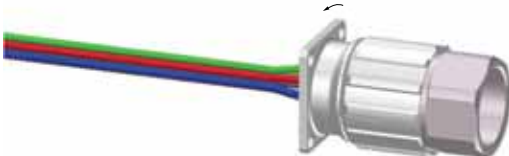

Panel Connector with knurled Nut

1.  4mm
2.  Crimp
3.  click
5.  click
6.  Code
7. 
8. 



7.010.900.101

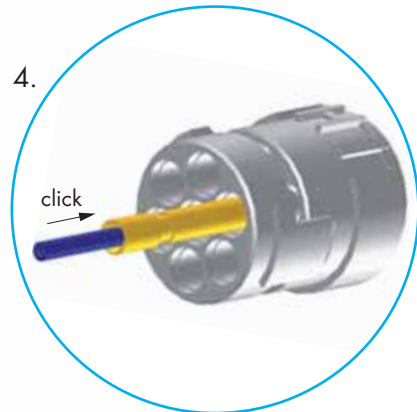

## Panel Connectors, Male Inserts

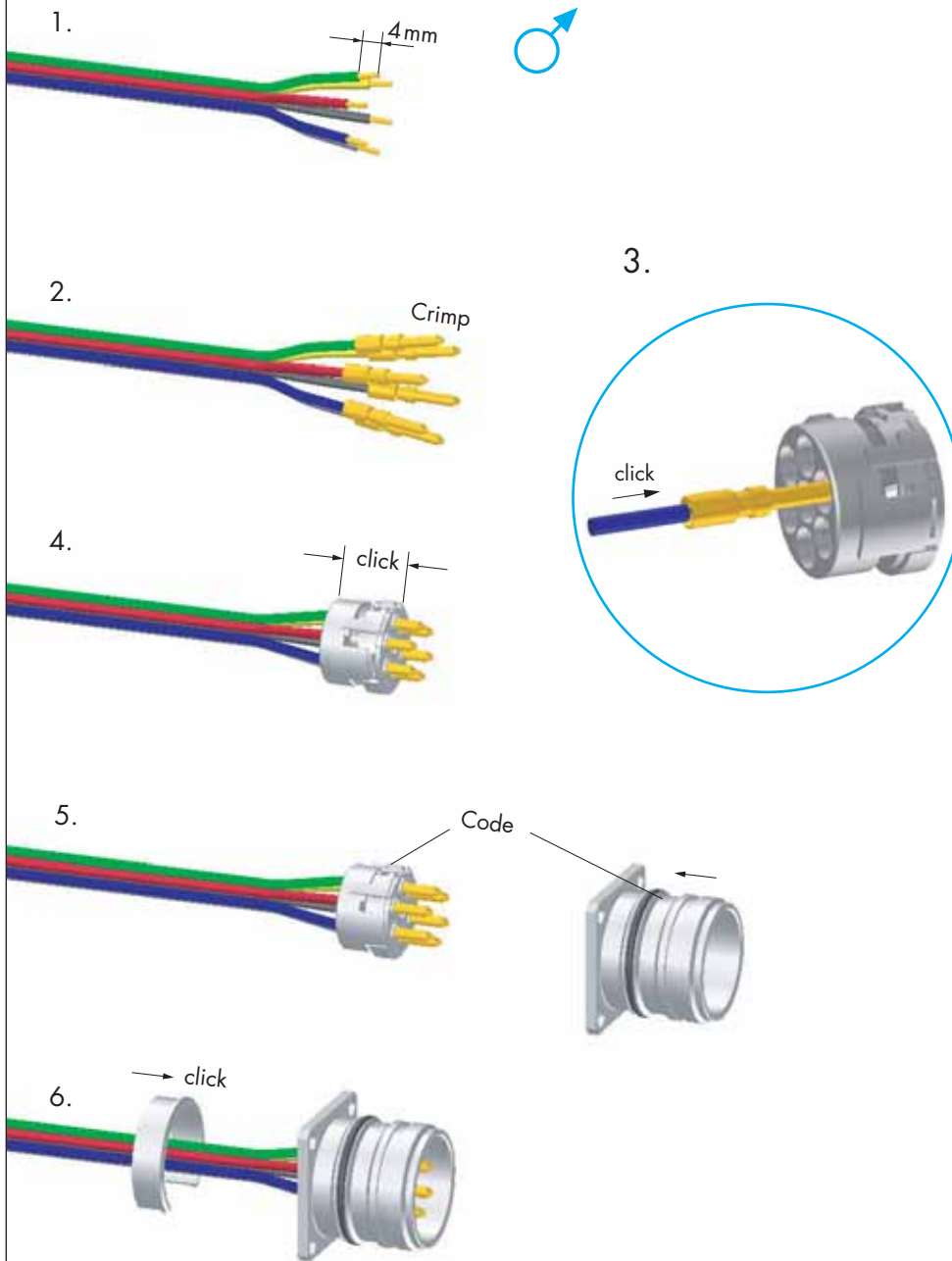

## Panel Connectors, Female Inserts

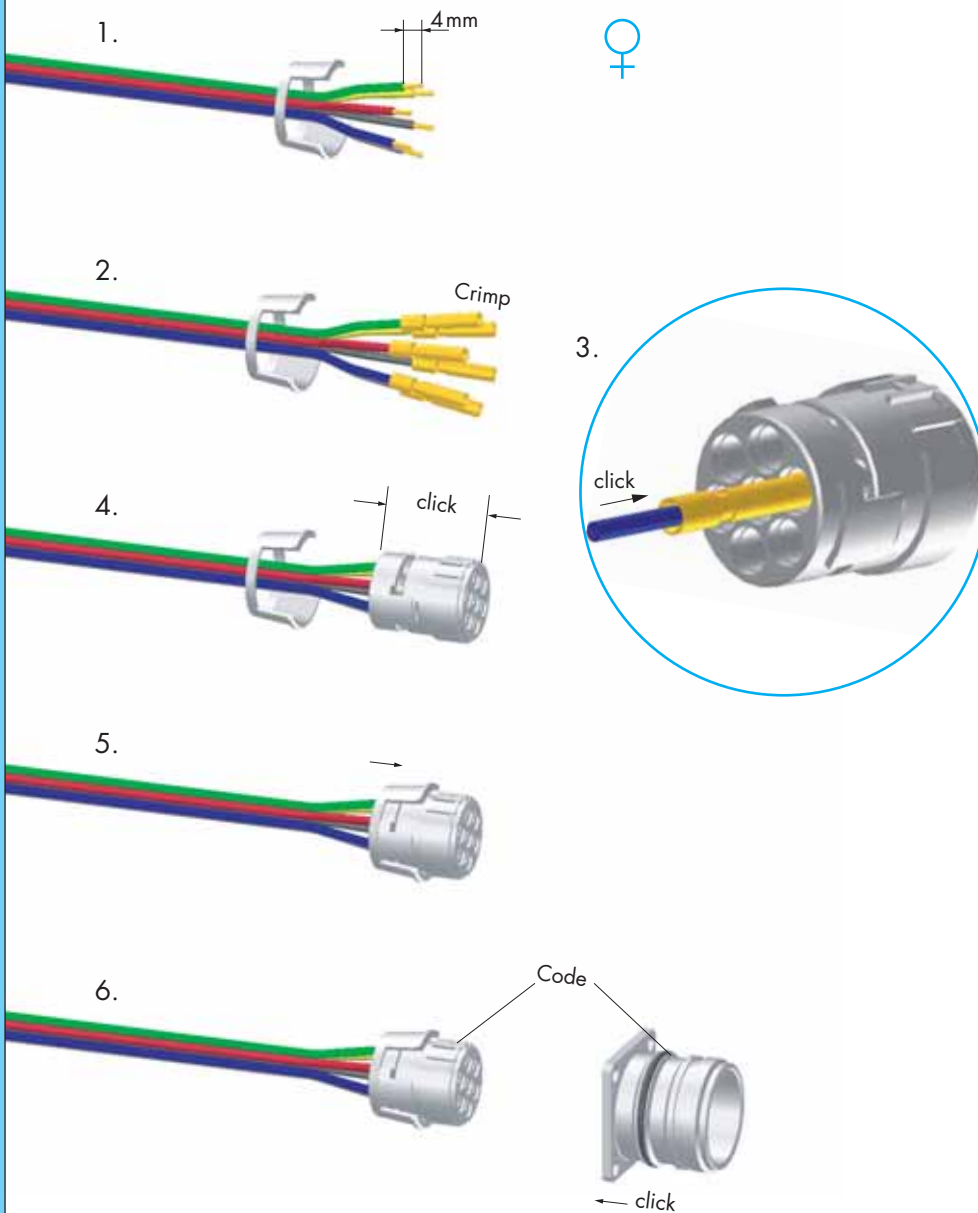

# Signal Connectors M23 / Assembly Instructions

## Right Angle Panel Connector

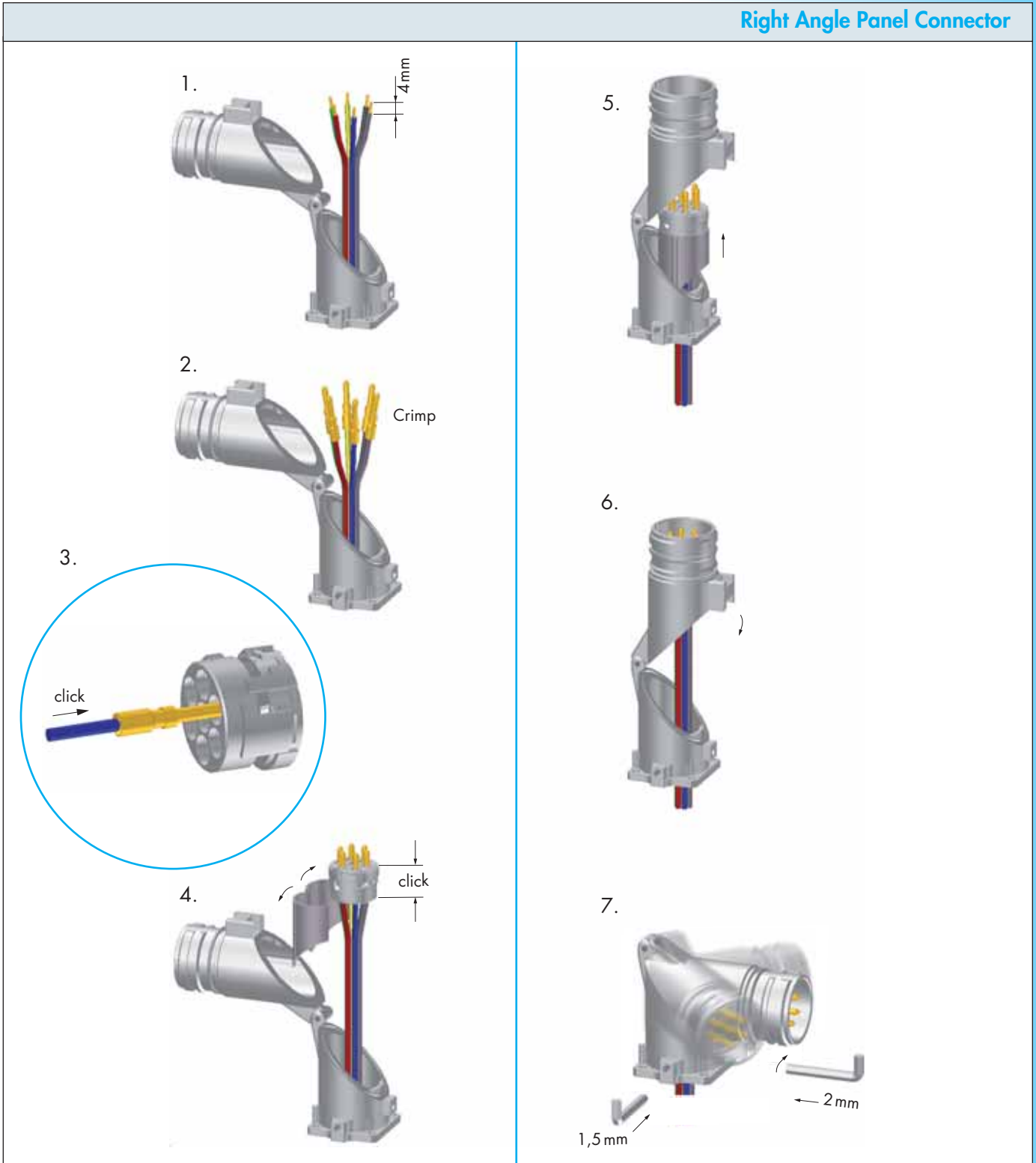

## Crimping, Assembly and Disassembly of Contacts

### Crimping, Assembly and Disassembly of Contacts

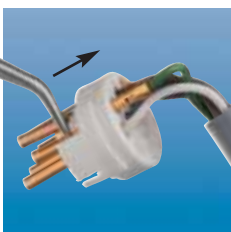
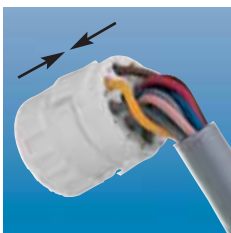
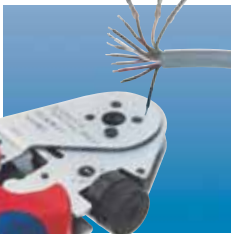

#### Crimping

- Remove conductor insulation 4 mm (.16") max.
- Select appropriate Crimp tool setting (see page 86)
- Insert Crimp contact into the positioner of the tool
- Insert stripped end of conductor into the crimp opening of the contact
- Squeeze handles of crimp tool together

#### Assembly

- Open crimping jaws and remove contact
- Pry open upper and lower insert approx. 3 mm (1/8") apart as shown
- Insert the contact and conductor assembly into the desired location
- Press upper and lower insert parts together

#### Disassembly

No special tools are needed to remove the crimp contacts from the insert.

- Remove upper part of insert
- With a pair of needle nose pliers, wiggle the contact and push it back through the lower part of insert
- Insert contacts into new location and push until it snaps in position
- Align the nose and groove of the upper and lower part of insert and press together

#### Shielding

- Assemble strain relief insert with insert
- Fold stranding of the shield back over the first O-Ring of the strain relief insert
- Cut back the overextending braid

The stranding of the shield is not allowed to touch the second O-Ring. Otherwise the assembly may not be proof.

## Connectors M 27



Housings

page 98



Inserts

page 99

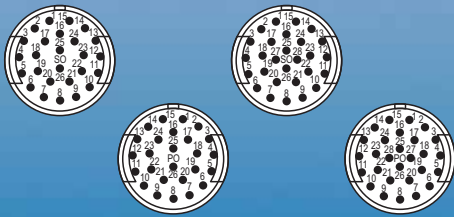

Accessories

page 101





## M 27 Signal Connectors

Mechanical Data	Materials and Technical Data
Housing	Copper-Zinc alloy Die Casting
Housing surface	Nickel plated other surface upon request
Inserts (for contacts)	Thermoplastic Polyamid PA 6 (Nylon 6/6), PBT    Fire protection class V-0
Contacts	Brass Alloy
Contact surface at point of contact	Nickel and gold plated (0,25µm Au)
Minimum mating cycles	> 1000
Seals / O-Rings	Buna-N standard optional Viton® (Viton is a registered trademark of DuPont)
Temperature range	-40°C – 125°C (-40°F – 257°F)
Type of contacts	Crimp, solder, dip-solder (PCB)
Protection	IP 67 / IP 69 K per EN 60529 (connected), NEMA 4x
Cable diameter range	7 – 17 mm (.28 – .55")

Electrical Data			
Number of positions		26	28
Number of contacts		26	28
Contact-Ø [mm]		1	1
Nominal current <sup>1)</sup> [A]		8	8
Nominal voltage <sup>2)</sup> [V~]		150	150
Test voltage (Breakdown voltage) <sup>3)</sup> [V~]		1500	1500
Insulation resistance [MΩ]		> 10 <sup>12</sup>	> 10 <sup>12</sup>
Max. contact resistance [mΩ]		3	3
Degree of Protection <sup>4)</sup>		3	3

<sup>1)</sup>, <sup>2)</sup>, <sup>3)</sup>, <sup>4)</sup> See Technical Informations page 14

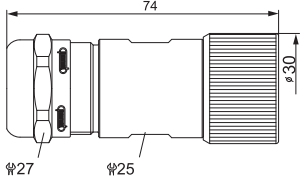

## Signal Connectors M27 / Housing

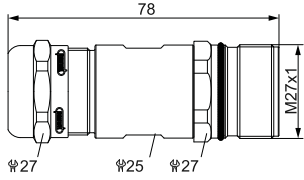
Straight Connector, Female Thread		Cable-Ø	Part Number
		7 – 12 mm (.28 - .47")	7.110.500.000
		11 – 17 mm (.43 - .67")	7.110.600.000
Contacts and inserts page 99 • Assembly instructions page 103			

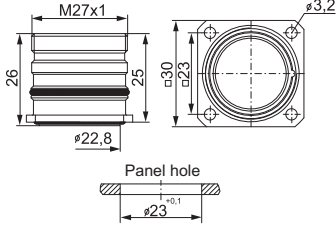
Straight Connector, Male Thread		Cable-Ø	Part Number
		7 – 12 mm (.28 - .47")	7.210.500.000
		11 – 17 mm (.43 - .67")	7.210.600.000
Contacts and inserts page 99 • Assembly instructions page 103			

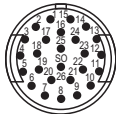
Panel Connector, Male Thread, front mounting		Type	Part Number
		4 x holes 3,2 mm	7.410.700.000
		Contacts and inserts page 99 • Assembly instructions page 104	

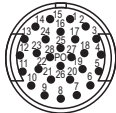
Type	Part Number	Part Number	Inserts 26-pole
<b>Pinout clockwise</b>	<b>Pins</b>	<b>Sockets</b>	
Insert with solder contacts .....	7.001.926.103 .....	7.001.926.104 .....	 Insert pin mating view
Insert without contacts .....	7.003.926.101 .....	7.003.926.102 .....	
Insert with dip solder contacts Length 3,5 mm .....	7.001.926.107 .....		 Insert socket mating view
Insert with dip solder contacts Length 10 mm .....	7.001.926.127 .....		
<p><b>The correct dimension of a connector with dip solder contacts depends on the particular type of housing.</b></p>			
Contacts page 100			

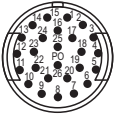
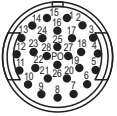

Type	Part Number	Part Number	Inserts 28-pole
<b>Pinout clockwise</b>	<b>Pins</b>	<b>Sockets</b>	
Insert with solder contacts .....	7.001.928.103 .....	7.001.928.104 .....	 Insert pin mating view
Insert with dip solder contacts Length 3,5 mm .....	7.001.928.107 .....		
Insert with dip solder contacts Length 10 mm .....	7.001.928.127 .....		 Insert socket mating view
<p><b>The correct dimension of a connector with dip solder contacts depends on the particular type of housing.</b></p>			
Contacts page 100			

## Signal Connectors M 27 / required contacts

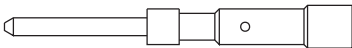
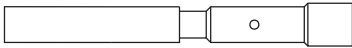
Contact Arrangement	Number of Poles	Required Contacts
	26 .....	26 x 1 mm
	28 .....	28 x 1 mm

Contacts	Type	Crimp Range	Part Number
	Crimp pin 1 mm, machined .....	0,14 – 1 mm <sup>2</sup> (AWG 26 – 17) .....	7.010.971.001
	Crimp socket 1 mm, machined ...	0,14 – 1 mm <sup>2</sup> (AWG 26 – 17) .....	7.010.971.002

Crimp Tool Settings see page 102

Type	Part Number	Accessories
Plastic protective cap for connectors with male thread .....7.000.980.167 for connectors with female thread .....7.000.980.168		
Brass protective cap for connectors with female thread .....7.010.900.169  Brass protective cap with chain for connectors with female thread .....Length 70 mm .....7.010.9S0.707		
Brass protective cap for connectors with male thread .....7.010.900.170 Brass protective cap with chain for connectors with male thread .....Length 70 mm .....7.010.9S0.708		
Crimp tool for manual crimping of machined crimp contacts. Works with contacts for power or signal M27. ....7.000.900.901  See page 118/119 for crimp tool instructions and page 102 proper setting		
Assembly tool .....7.010.900.110		

## Crimp Tool for Signal Connectors M27

### Crimp Tool Setting for HUMMEL Crimp Contacts (Crimp Tool 7.000.900.901)

Part Number	Crimp Contact	Cross Section mm <sup>2</sup>	AWG	Crimp Tool Setting mm	Locator Setting
7.010.971.001	Crimp pin (signal) 1 mm	0,14	26	0,70	1
		0,25	24	0,80	1
		0,34	22	0,88	1
		0,50	20	0,95	1
		0,75	18	1	1
		1	17	1,03	1
7.010.971.002	Crimp socket (signal) 1 mm	0,14	26	0,70	4
		0,25	24	0,80	4
		0,34	22	0,88	4
		0,50	20	0,95	4
		0,75	18	1	4
		1	17	1,03	4

# Signal Connectors M27 / Assembly Instructions

## Straight Connector, Female Thread

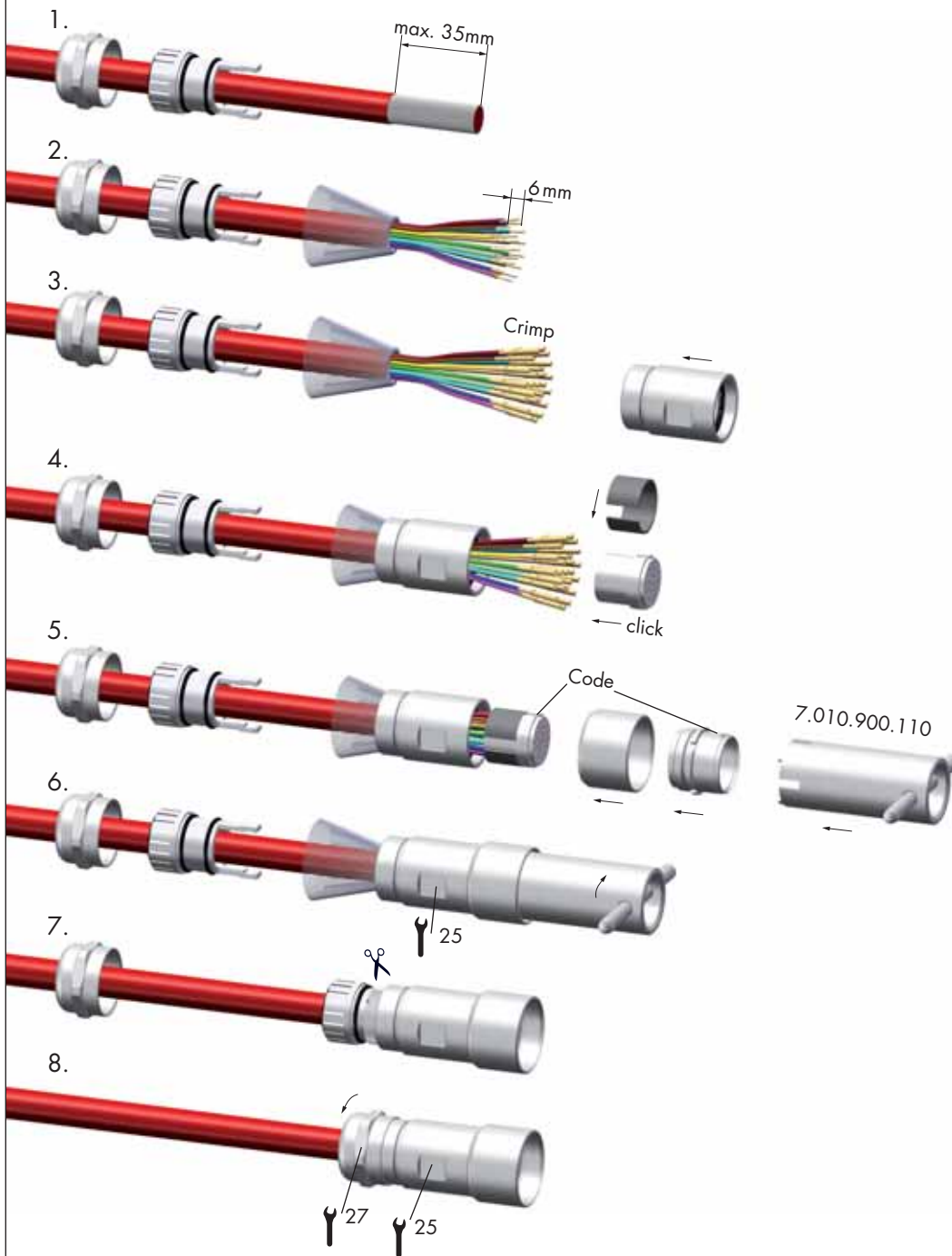

## Panel Connector

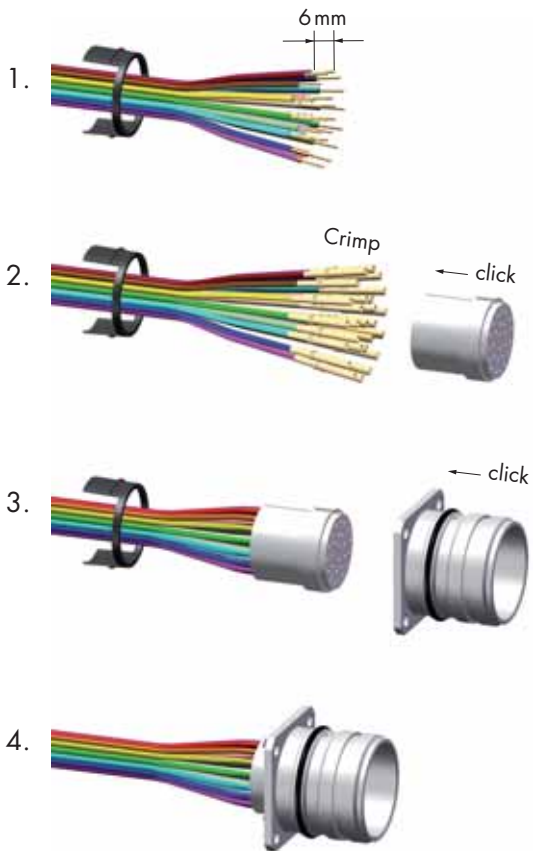



## Power Connectors M 23



Housings

page 108



Inserts

page 114

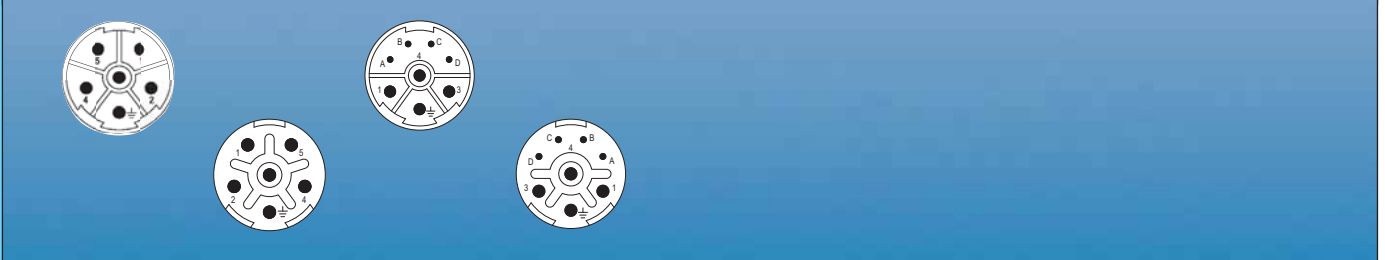

Accessories

page 116



## Power Connectors M23

Mechanical Data	Materials and Technical Data
Housing	Copper-Zinc alloy Die Casting
Housing surface	Nickel plated other surface upon request
Inserts (for contacts)	Thermoplastic Polyamid PA 6 (Nylon 6/6), PBT    Fire protection class V-0
Contacts	Brass Alloy
Contact surface at point of contact	Nickel and gold plated (0,25 µm Au)
Minimum mating cycles	> 1000
Seals / O-Rings	Buna-N standard optional Viton® (Viton is a registered trademark of DuPont)
Temperature range	-40° C – 125° C (-40 °F – 257 °F)
Type of contacts	Crimp
Protection	IP 67 / IP 69 K per EN 60 529 (connected), NEMA 4x
Cable diameter range	7 – 17 mm (.28 – .55")

Electrical Data	5 + PE	4 + 3 + PE	
Number of positions	6	4	4
Number of contacts	6	4	4
Contact-Ø [mm]	2	1	2
Nominal current <sup>1)</sup> [A]	28	8	28
Nominal voltage <sup>2)</sup> [V~] Degree of Protection 2 <sup>3)</sup>	800	300	800
Nominal voltage <sup>2)</sup> [V~] Degree of Protection 3 <sup>3)</sup>	600	300	600
Test voltage (Breakdown voltage) <sup>4)</sup> [V~]	4000	2500	4000
Insulation resistance [mΩ]	> 10 <sup>13</sup>	> 10 <sup>13</sup>	
Max. contact resistance [mΩ]	3	3	

<sup>1)</sup>, <sup>2)</sup>, <sup>3)</sup>, <sup>4)</sup> See Technical Informations page 14

## Power Connectors M 23 / Housing

### Straight Connector, Female Thread

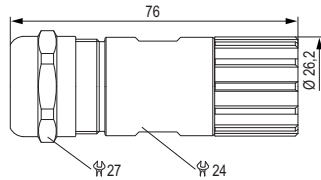

#### Cable-Ø

#### Part number

7 – 12 mm (.24 – .47").....7.550.500.000  
 11 – 17 mm (.43 – .67").....7.550.600.000

Contacts and inserts page 114 • Assembly instructions page 122

### Straight Connector, Female Thread, MZ

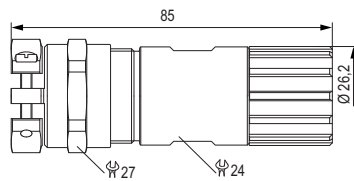

#### Cable-Ø

#### Part Number

10 – 12 mm (.39 – .47").....7.559.500.000  
 11 – 17 mm (.43 – .67").....7.559.600.000

Contacts and inserts page 114 • Assembly instructions page 122

### Straight Connector, Male Thread

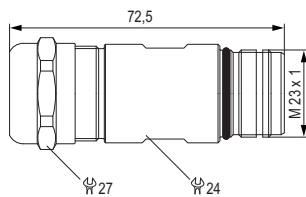

#### Cable-Ø

#### Part Number

7 – 12 mm (.24 – .47").....7.560.500.000  
 11 – 17 mm (.43 – .67").....7.560.600.000

Contacts and inserts page 114 • Assembly instructions page 122

### Straight Connector, Male Thread, MZ

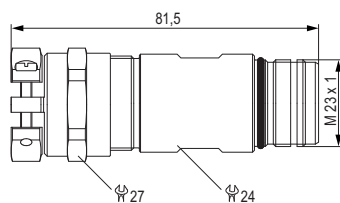



#### Cable-Ø



#### Part Number

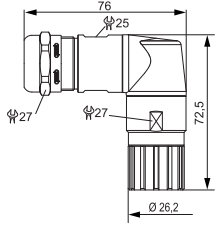

10 – 12 mm (.39 – .47").....7.569.500.000  
 11 – 17 mm (.43 – .67").....7.569.600.000

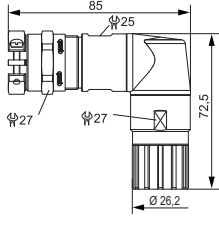

Contacts and inserts page 114 • Assembly instructions page 122

## Power Connectors M 23 / Housing

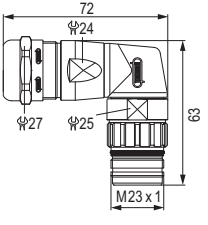
Cable-Ø	Part Number	Right Angle Connector with positioning, Female Thread
7 – 12 mm (.24 – .47").....	7.576.500.000	 
11 – 17 mm (.43 – .67").....	7.576.600.000	
Contacts and inserts page 114 • Assembly instructions page 124		

Cable-Ø	Part Number	Right Angle Connector with positioning, Female Thread, MZ
9 – 12 mm (.35 – .47").....	7.579.500.000	 
10 – 14 mm (.39 – .55").....	7.579.600.000	
Contacts and inserts page 114 • Assembly instructions page 124		

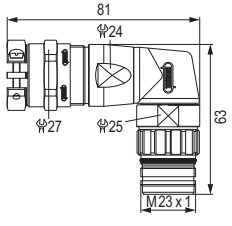
Cable-Ø	Part Number	Right Angle Connector, Male Thread
7 – 12 mm (.24 – .47").....	7.580.500.000	 
10 – 14 mm (.39 – .55").....	7.580.600.000	
Contacts and inserts page 114 • Assembly instructions page 124		

Cable-Ø	Part Number	Right Angle Connector, Male Thread, MZ
9 – 12 mm (.35 – .47").....	7.589.500.000	 
10 – 14 mm (.39 – .55").....	7.589.600.000	
Contacts and inserts page 114 • Assembly instructions page 124		

## Power Connectors M 23 / Housing

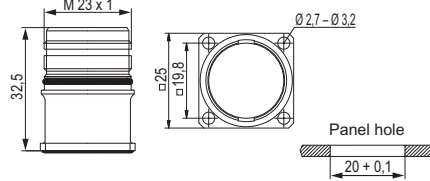
Panel Connectors, Male Thread, Front Mounting		Type	Part Number
		4 holes $\varnothing$ 3,2 mm (.13").....	7.601.000.000
		4 holes $\varnothing$ 2,7 mm (.11").....	7.605.000.000
		<b>Optional:</b> Flat gasket	
		Contacts and inserts page 114 • Assembly instructions page 125	

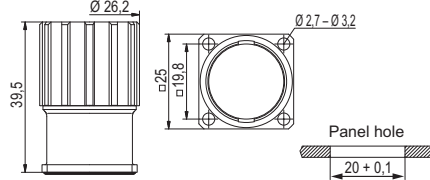
Panel Connector with knurled Nut, Front Mounting		Type	Part Number
		4 holes $\varnothing$ 3,2 mm (.13").....	7.641.000.000
		4 holes $\varnothing$ 2,7 mm (.11").....	7.645.000.000
		<b>Optional:</b> Flat gasket	
		Contacts and inserts page 114 • Assembly instructions page 125	

## Power Connectors M 23 / Housing

Type	Part Number	Panel Connector, Male Thread, Single Hole Mounted	
<b>Front mounting</b> Thread M 20 x 1,5 .....7.621.000.000			
<b>Options:</b> Flat gasket, jam nut M 20 x 1,5			
Contacts and inserts page 114 • Assembly instructions page 126			



Type	Part Number	Panel Connector, Male Thread, Single Hole Mounted	
<b>Front mounting</b> Thread PG 13,5 .....7.623.000.000			
<b>Options:</b> Flat gasket, jam nut PG 13,5			
Contacts and inserts page 114 • Assembly instructions page 126			



Type	Part Number	Panel Connector, Male Thread, Single Hole Mounted	
<b>Front mounting</b> Thread M 25 x 1,5 .....7.626.000.000			
<b>Options:</b> Flat gasket, jam nut M 25 x 1,5			
Contacts and inserts page 114 • Assembly instructions page 126			



Type	Part Number	Panel Connector, Male Thread, Single Hole Mounted	
<b>Rear mounting</b> Thread M 25 x 1,5 .....7.651.000.000			
Including jam nut M 25 x 1,5			
Contacts and inserts page 114 • Assembly instructions page 126			



## Power Connectors M 23 / Housing

Right Angle Panel Connector, Male Thread		Type	Part Number
		4 holes $\varnothing$ 2,7 mm (.11") .....7.635.000.000	
		<b>Options:</b> Flat gasket  Easy fastening with M2,5 x 10 mm or #4 x .39" long screws	
		Contacts and inserts page 114 • Assembly instructions page 127	

Right Angle Panel Connector, Male Thread, rotatable		Type	Part Number
		<b>335° rotatable, single hole mounted</b>	
		Thread M 20 x 1,5 .....7.636.000.000	
		Contacts and inserts page 114 • Assembly instructions page 127	

Right Angle Panel Connector, Male Thread, rotatable		Type	Part Number
		<b>335° rotatable, single hole mounted</b>	
		Thread PG 13,5 .....7.637.000.000	
		Contacts and inserts page 114 • Assembly instructions page 127	

Rotating Panel Elbow Connector, rotatable		Type	Part Number
		<b>300° rotating, locking screw at flange</b>	
		4 x holes $\varnothing$ 2,7 mm (.11") ..7.638.000.000 Flange 25 x 25 mm  4 x holes $\varnothing$ 3,2 mm (.13") ..7.638.100.000 Flange 28 x 28 mm	
		Contacts and inserts page 114 • Assembly instructions page 127	



## Power Connectors M 23 / Housing

Type	Part Number	Panel Connector, Male Thread, Rear Mounting
<b>With anti-vibration O-Ring</b> 4 holes $\varnothing 3,2$ mm (.13") .....7.661.000.000		
Contacts and inserts page 114 • Assembly instructions page 123		





Cable- $\varnothing$	Part Number	Panel Connector, Male Thread, with Strain Relief
<b>Single hole mounted, rear mounting, thread M 25 x 1,5</b> 7 – 12 mm (.27 – .47") .....7.653.500.000 11 – 17 mm (.43 – .67") .....7.653.600.000		
Including jam nut M25 x 1,5		
Contacts and inserts page 114 • Assembly instructions page 122		

Cable- $\varnothing$	Part Number	Panel Connector, Female Thread, with Strain Relief
<b>4 holes <math>\varnothing 3,2</math> mm (.13"), front or rear mounting</b> 7 – 12 mm (.27 – .47") .....7.681.500.000 11 – 17 mm (.43 – .67") .....7.681.600.000		
Contacts and inserts page 114 • Assembly instructions page 122		

Cable- $\varnothing$	Part Number	Panel Connector, Male Thread, with Strain Relief
<b>4 holes <math>\varnothing 3,2</math> mm (.13"), front or rear mounting</b> 7 – 12 mm (.27 – .47") .....7.683.500.000 11 – 17 mm (.43 – .67") .....7.683.600.000		
Contacts and inserts page 114 • Assembly instructions page 122		

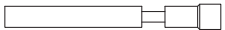
## Power Connectors M 23 / Inserts

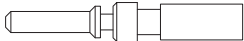
Contact Arrangement, Mating View	Type of Contact	Part Number
	6 x crimp pins 2 mm	7.084.951.101
	6 x crimp sockets 2 mm	7.084.951.102
	4 x crimp pins 1 mm 4 x crimp pins 2 mm	7.084.943.101
	4 x crimp sockets 1 mm 4 x crimp sockets 2 mm	7.084.943.102

Type of Contact	Crimp Range	Part Number	Contacts
Crimp pin 1 mm, machined	0,25 – 1 mm <sup>2</sup> ..... (AWG 24 – 17)	7.010.941.001	
Crimp socket 1 mm, machined	0,25 – 1 mm <sup>2</sup> ..... (AWG 24 – 17)	7.010.941.002	
Crimp pin 2 mm, machined	0,75 – 2,5 mm <sup>2</sup> ..... (AWG 18 – 14)	7.010.942.001	
Crimp pin 2 mm, machined	2,5 – 4 mm <sup>2</sup> ..... (AWG 14 – 12)	7.010.942.011	
Crimp socket 2 mm, machined	0,75 – 2,5 mm <sup>2</sup> ..... (AWG 18 – 14)	7.010.942.002	
Crimp socket 2 mm, machined	2,5 – 4 mm <sup>2</sup> ..... (AWG 14 – 12)	7.010.942.012	

See page 128 for crimp tool instructions and proper setting

## Power Connectors M 23 / Accessories

Accessories	Type	Part Number
	Plastic protective cap	
	for connectors with male thread .....	7.000.900.101
	for connectors with female thread .....	7.000.900.102
	Brass protective cap	
	for connectors	
	with female thread .....	7.010.900.183
	Brass protective cap	
	for connectors	
	with male thread .....	7.010.900.102
	Brass protective cap	
	with chain for connectors	
	with female thread .....	Length 70 mm .....7.010.9S0.783
		Length 100 mm .....7.010.9S1.083
	Brass protective cap	
	with chain for connectors	
	with male thread .....	Length 70 mm .....7.010.9S0.702
		Length 100 mm .....7.010.9S1.002

Type	Part Number	Accessories
<p>Crimp tool for manual crimping of machined crimp contacts. Works with contacts for power or signal.....</p> <p>Operating instructions on page 118</p>	7.000.900.901	
<p>Adaptor flange for Straight Connectors .....</p>	7.010.900.128	
<p>Adapter for Conduit Fittings</p> <p>Snapflex 16.....</p> <p>DN 12 .....</p> <p>Snapflex 20.....</p> <p>DN 14 .....</p> <p>Snapflex 25.....</p> <p>DN 17 .....</p>	<p>7.010.900.204</p> <p>7.010.900.205</p> <p>7.010.900.206</p> <p>7.010.900.207</p> <p>7.010.900.208</p> <p>7.010.900.209</p>	

Type	Part Number	for HUMMEL Contact	Locator
<p>Locator for Crimp Tool DMC M22520 with positioner ....</p> <p>Locator for Crimp Tool DMC M22520 with positioner ....</p>	<p>7.000.9DM.C06 .....</p> <p>7.000.9DM.C07 .....</p>	<p>7.010.941.001, 7.010.942.001</p> <p>7.010.941.002, 7.010.942.002</p>	

# Crimp Tool for Power Connectors M 23

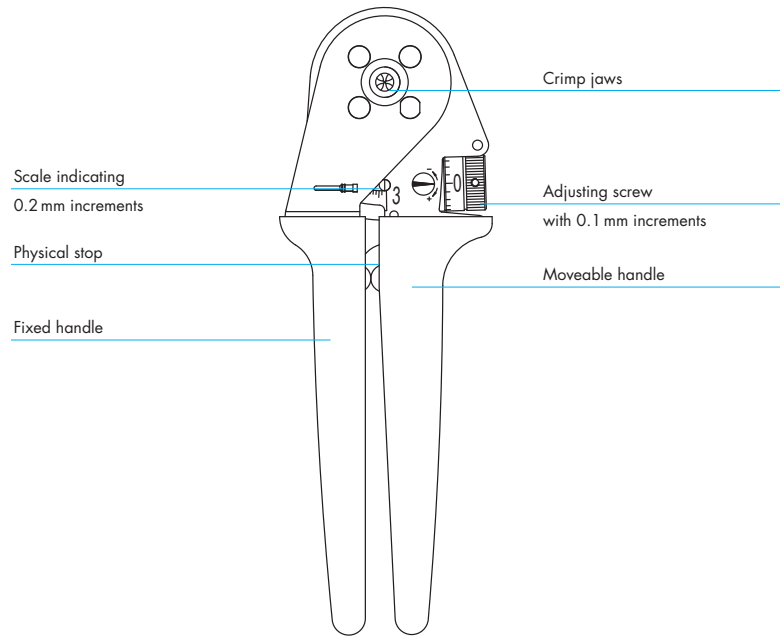
Crimp Tool	Type	Part Number
	<p>Crimp tool .....7.000.900.901</p> <p><b>Application</b> The four indent crimp tool 7.000.900.901 has been developed for optimal crimping of machined contacts with diameters from 0.14 to 6.0 mm<sup>2</sup> (26 through 10 AWG).</p> <p><b>How to Crimp</b> The reference table indicates the correct locator position to be selected and the crimp depth to be adjusted for the contact to be crimped. The contact is then inserted through the access hole of the tool on the opposite side of the locator. The contact is held in place by closing the handles to the first lock-in position thus preventing the contact from falling out of the tool and facilitating insertion of the wire into the contact. The precision ratchet assures consistently accurate crimping every time by forcing the tool to be closed all the way completing the crimping cycle before the tool can be opened again.</p> <p><b>Exchange of the Locator</b> The locator can be exchanged by removing the socket head cap screw with a socket wrench. It can then be disassembled from the hex head screw by turning it counter-clockwise.</p>	
		

## Crimp Tool

### Adjustment of Crimp Depth

Crimp depth can be adjusted as follows:

Turn the adjusting screw clockwise for reducing the crimp depth and counter-clockwise for increasing the crimp depth.

### Adjustment Increments:

- 1 space on the adjusting screw  $\hat{=}$  adjustment by 0.01 mm
- 1 full rotation of adjusting screw  $\hat{=}$  adjustment by 0.2 mm (indication on the screw as well as on the rough scale)
- 5 rotations of the adjusting screw  $\hat{=}$  adjustment by 1 mm (indication on the scale)

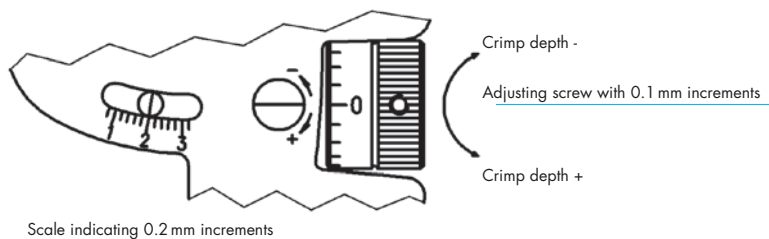

### Control of Crimp Depth

Crimp tool adjustment is done at the factory, but with frequent use, periodic calibration is recommended to insure accuracy. This is easily accomplished with a 2.0 mm  $\varnothing$  wire gauge as follows.

A crimp depth of 2.0 mm is set by means of the adjusting screw (scale mark at „2“, screw mark at „0“ as shown in the fig. above) and the tool in the closed position. After insertion of the gauge, there must be just enough space for moving the gauge inside the entry hole. If the opening is too small or too large to exactly match the gauge, the deviation (+/-) can be checked by the precision setting of the screw. Please contact the factory in case the deviation exceeds the tolerances specified by the contract manufacturer.

### Maintenance and Repair

Keep the tool clean and properly stored when not in service. All pivot points need to be oiled regularly and the spring clips securing the bolts have to always be in place. For repair please send the tool back to the factory.

## Crimp Tool for Power Connectors M 23

### Crimp Tool Setting for HUMMEL Crimp Contacts (Crimp Tool 7.000.900.901)

Part Number	Crimp Contact	Cross Section mm <sup>2</sup>	AWG	Crimp Tool Setting mm	Locator Setting
7.010.901.001	Crimp pin (signal) 1 mm	0,14	26	0,75	11
		0,25	24	0,82	11
		0,35	22	0,9	11
		0,50	20	1	11
		0,75	18	1,08	11
		1,0	17	1,2	11
7.010.901.012	Crimp socket (signal) 1 mm	0,14	26	0,75	12
		0,25	24	0,8	12
		0,35	22	0,87	12
		0,50	20	0,97	12
7.010.901.002	Crimp socket (signal) 1 mm	0,50	20	0,95	12
		0,75	18	1	12
		1,0	17	1,05	12
7.010.901.501	Crimp pin (signal) 1,5 mm	0,14	26	0,75	3
		0,25	24	0,82	3
		0,35	22	0,9	3
		0,50	20	0,96	3
		0,75	18	1,03	3
		1,0	17	1	3
7.010.901.512	Crimp socket (signal) 1,5 mm	0,14	26	0,75	4
		0,25	24	0,8	4
		0,35	22	0,87	4
		0,50	20	0,97	4
7.010.901.502	Crimp socket (signal) 1,5 mm	0,50	20	0,95	4
		0,75	18	1	4
		1,0	17	1,05	4
7.010.902.001	Crimp pin (signal) 2 mm	0,75	18	1,3	5
		1,0	17	1,4	5
		1,5	16	1,55	5
		2,5	14	1,75	5
7.010.902.002	Crimp socket (signal) 2 mm	0,75	18	1,3	6
		1,0	17	1,4	6
		1,5	16	1,55	6
		2,5	14	1,75	6
7.010.941.001	Crimp pin (power) 1 mm	0,14	26	0,75	1
		0,25	24	0,8	1
		0,35	22	0,85	1
		0,50	20	1,03	1
		0,75	18	1,08	1
		1,0	17	1,13	1



## Crimp Tool for Power Connectors M 23

### Crimp Tool Setting for HUMMEL Crimp Contacts (Crimp Tool 7.000.900.901)

Part Number	Crimp Contact	Cross Section mm <sup>2</sup>	AWG	Crimp Tool Setting mm	Locator Setting
7.010.941.002	Crimp socket (power) 1 mm	0,14	26	0,75	2
		0,25	24	0,8	2
		0,35	22	0,85	2
		0,50	20	0,89	2
		0,75	18	0,95	2
		1	17	1,02	2
7.010.942.001	Crimp pin (power) 2 mm	0,75	18	1,3	7
		1	17	1,4	7
		1,5	16	1,55	7
		2,5	14	1,7	7
7.010.942.011	Crimp pin (power) 2 mm	2,5	14	1,47	7
		4	12	1,6	7
7.010.942.002	Crimp socket (power) 2 mm	0,75	18	1,3	8
		1	17	1,4	8
		1,5	16	1,55	8
		2,5	14	1,7	8
7.010.942.012	Crimp socket (power) 2 mm	2,5	14	1,47	8
		4	12	1,6	8

These values are only guidelines and actual conductor cross sections depend on manufacturer tolerances.  
Please see assembly instructions on page 128

# Power Connectors M 23 / Assembly Instructions

## Straight Connector, Female Thread

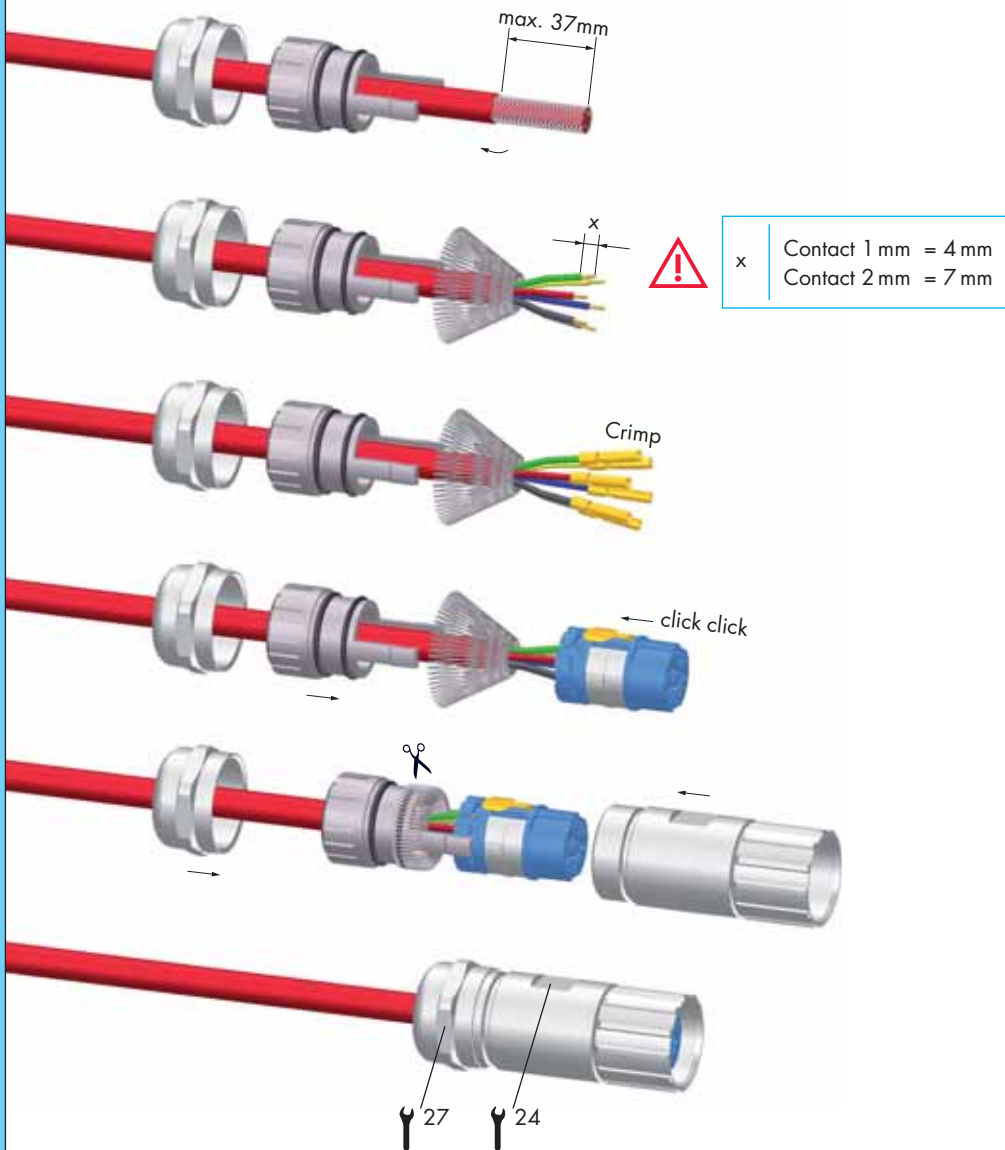

## Panel Connector, Male Thread

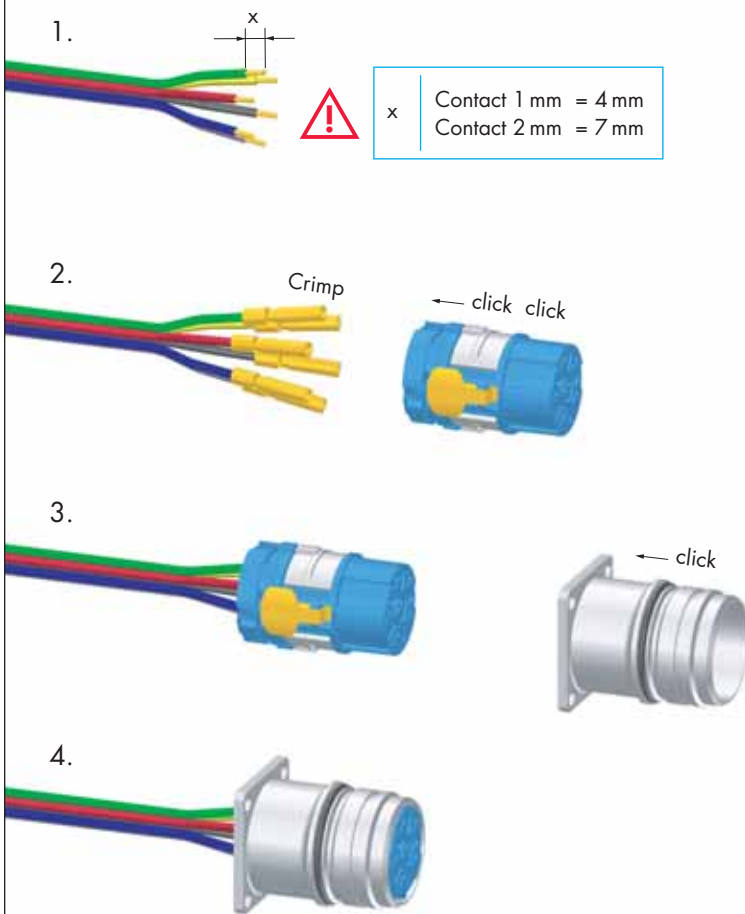

# Power Connectors M 23 / Assembly Instructions

## Right Angle Connector with positioning

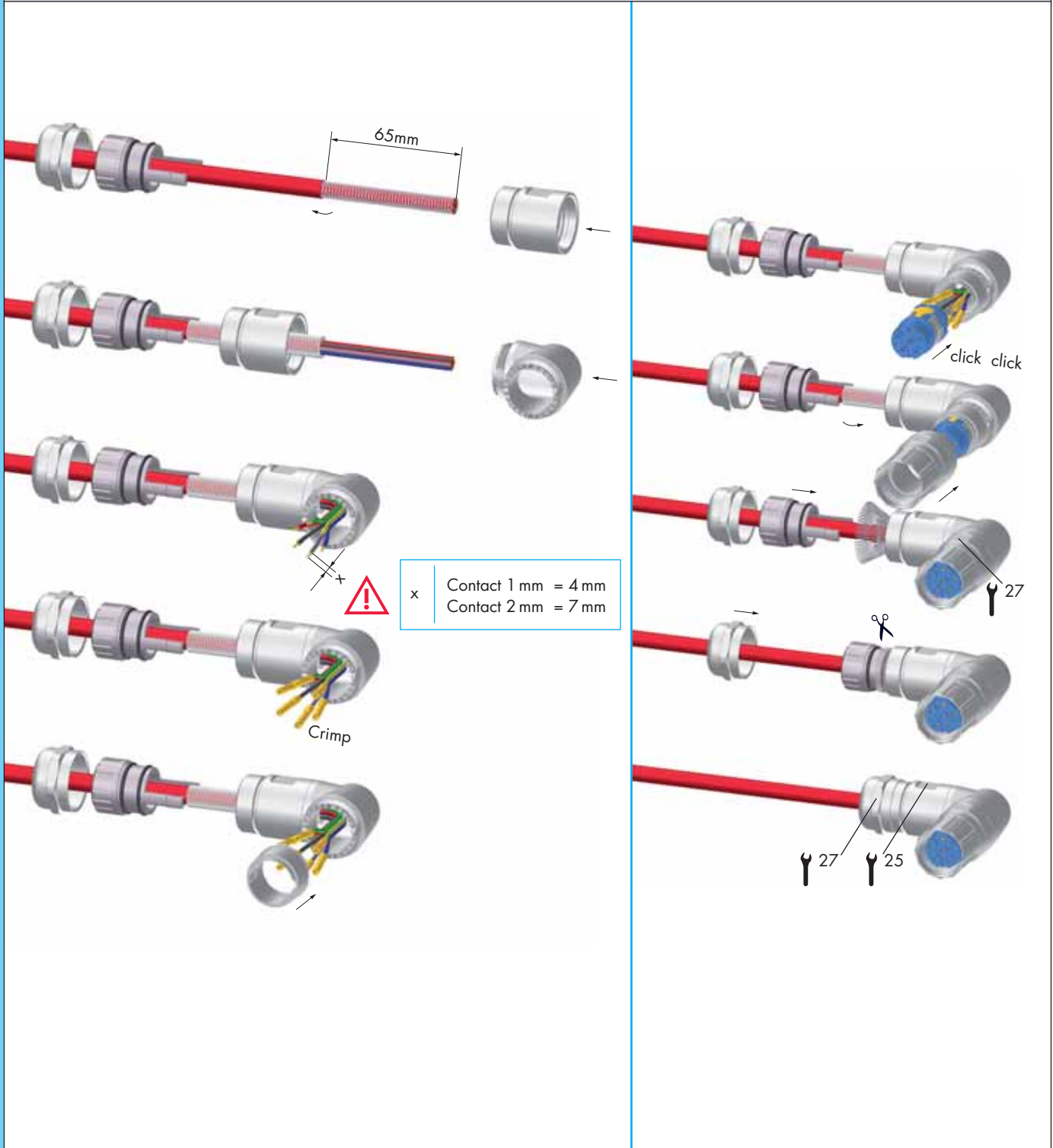

## Panel Connector, Female Thread

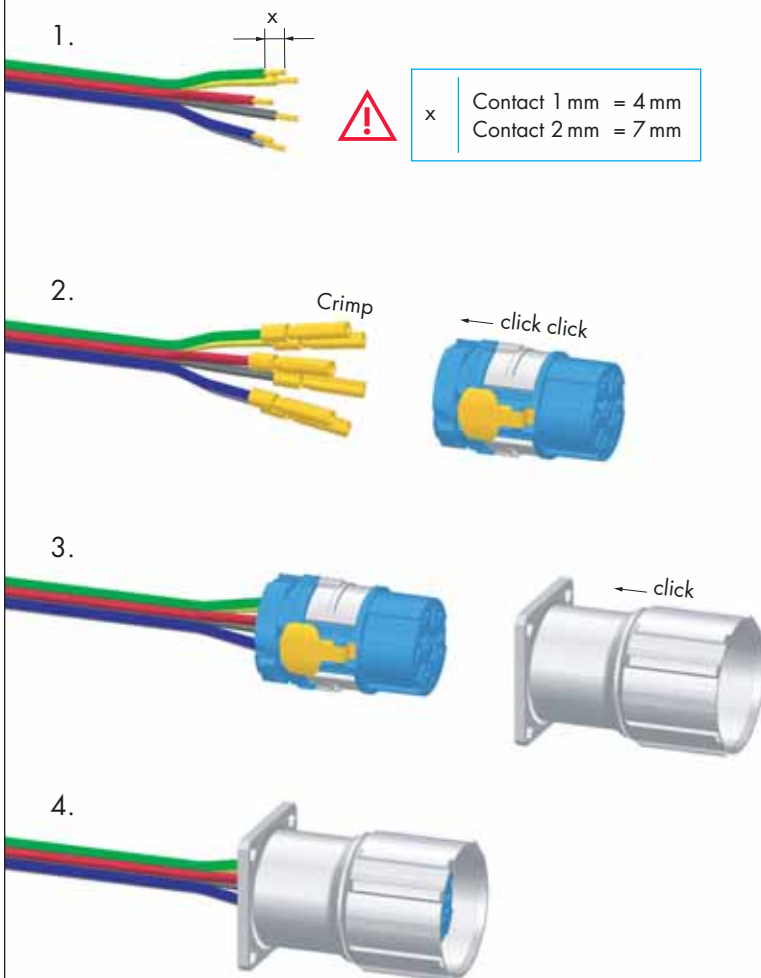

## Panel Connector, Male Thread, Single Hole Mounted

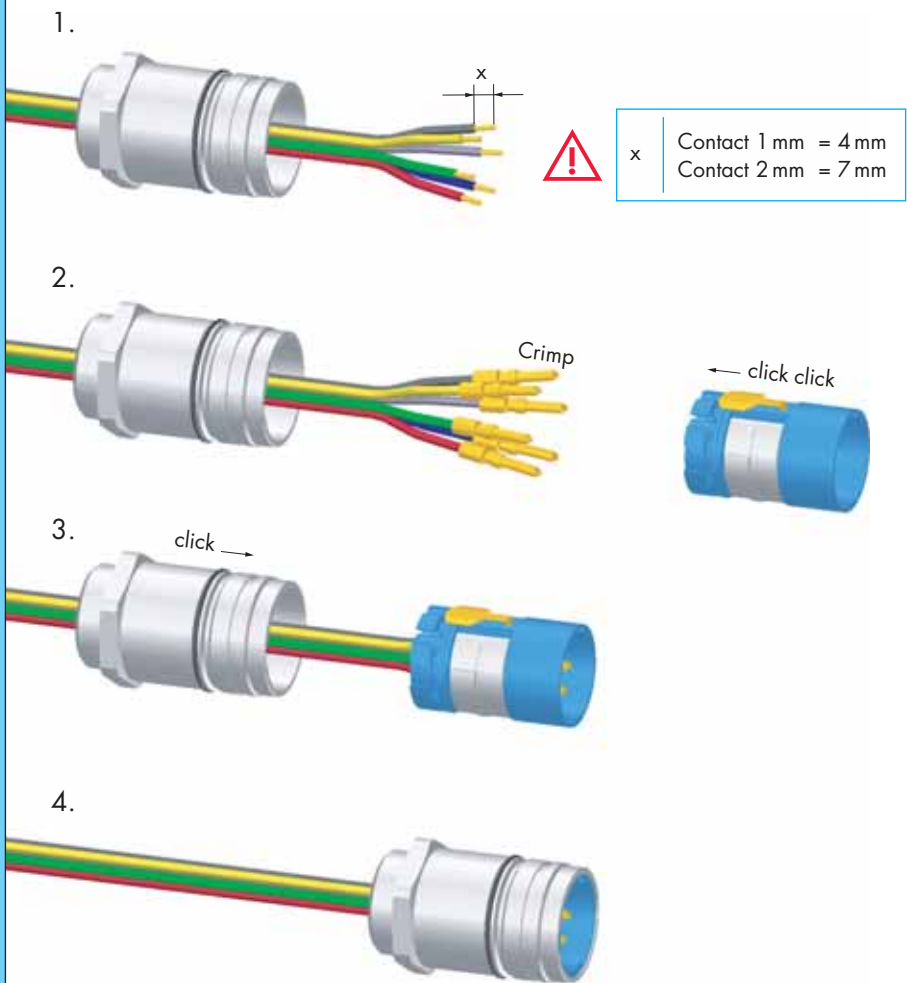

# Power Connectors M23 / Assembly Instructions

## Right Angle Panel Connector

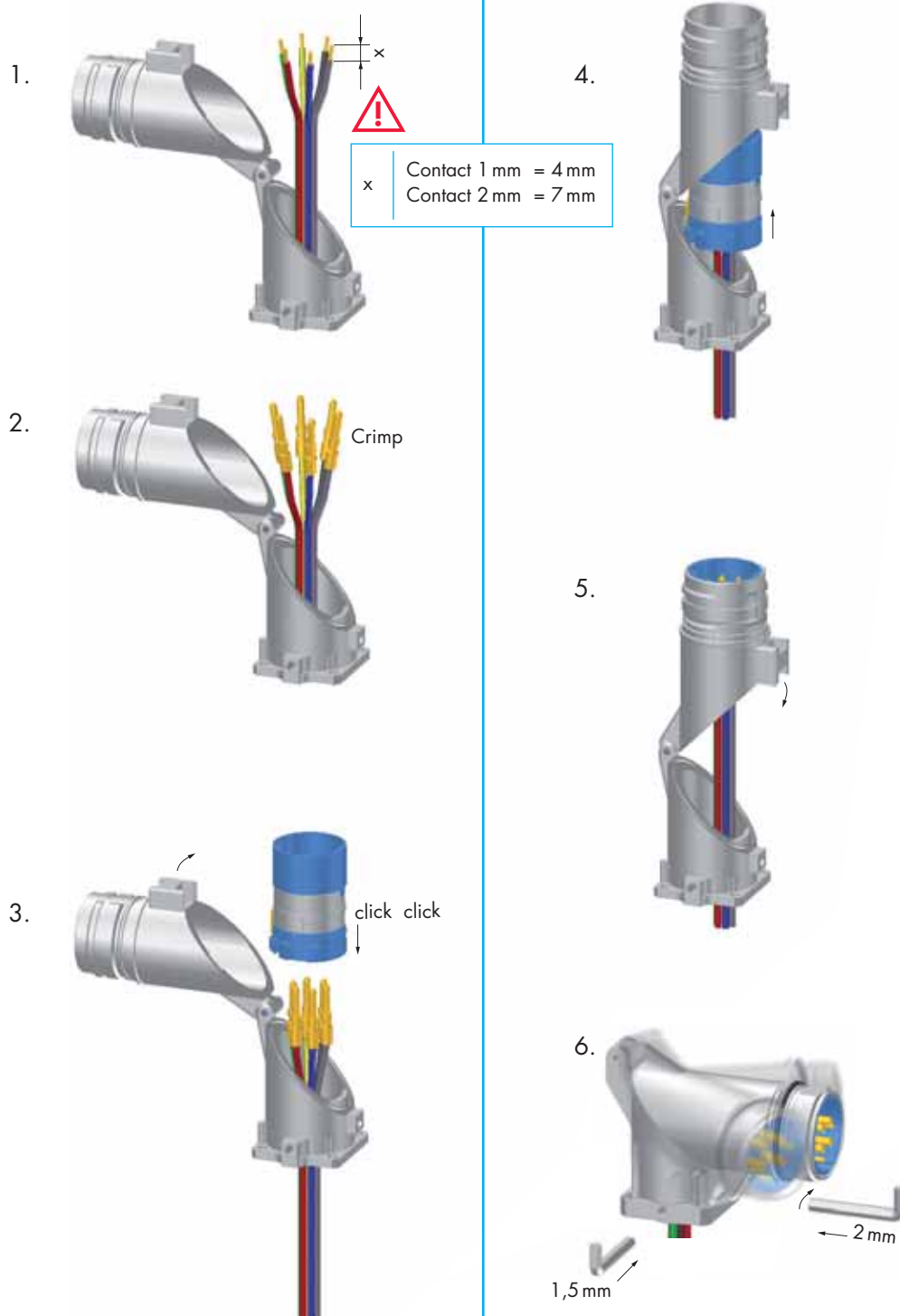

## Crimping, Assembly and Disassembly

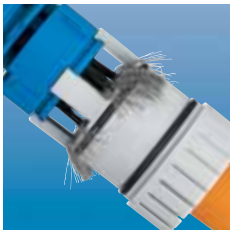
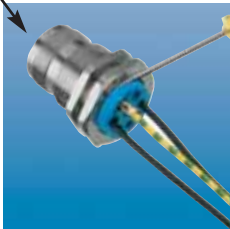
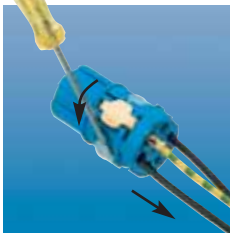
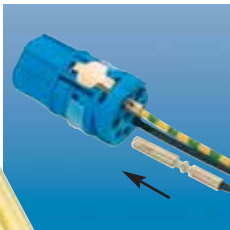
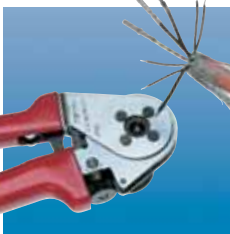

### Crimping

- For 1 mm contacts strip wire ends 4 mm (.16") max., for 2 mm contacts strip wire ends 7 mm (.28") max.
- Dial appropriate setting of crimping tool (page 120 / 121)
- Push crimp contact into opening of crimping tool
- Insert stripped wire into the funnel shaped end of the crimp contact
- Squeeze handles of crimping tool together, connecting contact to wire

### Assembly

- Remove crimped assembly and pull on wire to test connection
- Push into desired position of insert  
Note: For 8-pole inserts (4 + 3 + PE) it is recommended to assemble the large contacts first.

### Disassembly of Contacts from Insert

A small screw driver is required.

- Using the screw driver, push the white clip ring out of the insert
- Pull the contacts out of the insert
- Replace the white clip ring
- Re-insert the contacts

### Disassembly of Insert from Housing

A small screw driver is required. Push locking tongue, located above the PE-contact, down. By simultaneously pushing on the front side of the insert, it can be disassembled from the housing.

### Shielding

- Assemble strain relief insert with insert
- Fold stranding of the shield back over the first O-Ring of the strain relief insert
- Cut back the overextending braid

 The stranding of the shield is not allowed to touch the second O-Ring. Otherwise the assembly may not be proof.



## Power Connectors Size 1,5 (M 40)



Housings

page 132



Inserts

page 135

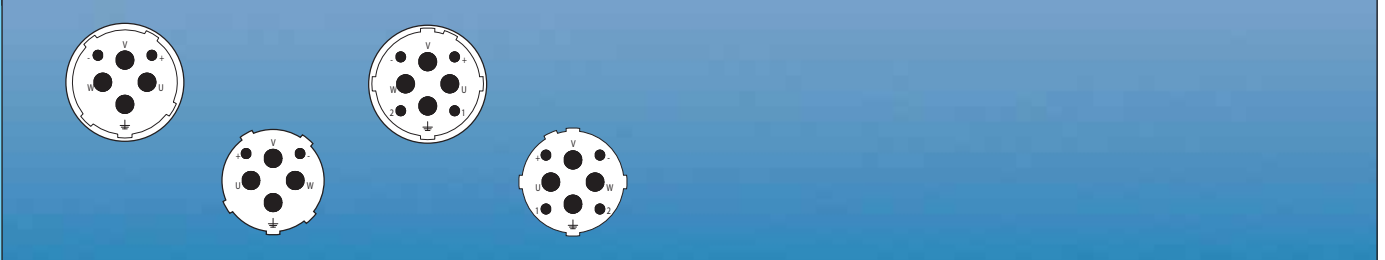

Accessories

page 138



## Power Connectors Size 1,5 (M40)

Mechanical Data	Materials and Technical Data
Housing	Copper-Zinc alloy Die Casting
Housing surface	Nickel plated, other surface upon request
Inserts (for contacts)	Thermoplastic Polyamid PA 6 (Nylon 6/6), PBT Fire protection class V-0
Contacts	Brass Alloy
Contact surface at point of contact	Nickel and gold plated (0,25 µm Au)
Minimum mating cycles	> 500
Seals / O-Rings	Buna-N standard optional Viton® (Viton is a registered trademark of DuPont)
Temperature range	-40° C – 125° C (-40 °F – 257 °F)
Type of contacts	Crimp
Protection	IP 67 / IP 69 K per EN 60 529 (connected), NEMA 4x
Cable diameter range	13 – 28 mm (.51" – 1.10")

Electrical Data	3 + 2 + PE		4 + 3 + PE	
Number of positions				
Number of contacts	2	4	4	4
Contact Ø [mm]	2	3,6	2	3,6
Nominal current <sup>1)</sup> [A]	28	55	28	55
Nominal voltage <sup>2)</sup> [V~] Degree of Protection 2 <sup>3)</sup>	300	800	300	800
Nominal voltage <sup>2)</sup> [V~] Degree of Protection 3 <sup>3)</sup>	300	600	300	600
Test voltage (Breakdown voltage) <sup>4)</sup> [V~]	2500	4000	2500	4000
Insulation resistance [mΩ]	> 10 <sup>13</sup>		> 10 <sup>13</sup>	
Max. contact resistance [mΩ]	3	1	3	1

<sup>1), 2), 3), 4)</sup> See Technical Informations page 14

 Standard delivery of M40 (size 1.5) Power Connector include Contact Insert

## Power Connectors Size 1,5 (M 40)

Straight Connector, Female Thread		Cable-Ø	Part Number
			<b>2 + 3 + PE, insert for sockets</b> 13 – 18 mm (.51 – .71") .....7.710.623.000 17 – 24 mm (.67 – .97") .....7.710.723.000 21 – 28 mm (.83 – 1.10") ...7.710.823.000
			Contacts page 136 • Assembly instructions page 145

Straight Connector, Female Thread		Cable-Ø	Part Number
			<b>4 + 3 + PE, insert for sockets</b> 13 – 18 mm (.51 – .71") .....7.710.643.000 17 – 24 mm (.67 – .97") .....7.710.743.000 21 – 28 mm (.83 – 1.10") ...7.710.843.000
			Contacts page 136 • Assembly instructions page 145

Straight Connector, Male Thread		Cable-Ø	Part Number
			<b>2 + 3 + PE, insert for pins</b> 13 – 18 mm (.51 – .71") .....7.720.623.000 17 – 24 mm (.67 – .97") .....7.720.723.000 21 – 28 mm (.83 – 1.10") ...7.720.823.000
			Contacts page 136 • Assembly instructions page 145

Straight Connector, Male Thread		Cable-Ø	Part Number
			<b>4 + 3 + PE, insert for pins</b> 13 – 18 mm (.51 – .71") .....7.720.643.000 17 – 24 mm (.67 – .97") .....7.720.743.000 21 – 28 mm (.83 – 1.10") ...7.720.843.000
			Contacts page 136 • Assembly instructions page 145

## Power Connectors Size 1,5 (M 40)

Cable-Ø	Part Number	Panel Connector, Male Thread, Front Mounting			
<b>2 + 3 + PE, insert for pins</b> 4 holes Ø 4,5 mm (.18") .....7.740.023.000					
Contacts page 136 • Assembly instructions page 146					

Cable-Ø	Part Number	Panel Connector, Male Thread, Front Mounting			
<b>4 + 3 + PE, insert for pins</b> 4 holes Ø 4,5 mm (.18") .....7.740.043.000					
Contacts page 136 • Assembly instructions page 146					

Cable-Ø	Part Number	Panel Connector with knurled Nut, Front Mounting			
<b>2 + 3 + PE, insert for sockets</b> 4 holes Ø 4,5 mm (.18") .....7.744.023.000					
Contacts page 136 • Assembly instructions page 146					

Cable-Ø	Part Number	Panel Connector with knurled Nut, Front Mounting			
<b>4 + 3 + PE, insert for sockets</b> 4 holes Ø 4,5 mm (.18") .....7.744.043.000					
Contacts page 136 • Assembly instructions page 146					

## Power Connectors Size 1,5 (M 40)

Right Angle Panel Connector, Male Thread, rotatable		Type	Part Number
		<b>2 + 3 + PE, insert for pins</b> 4 holes Ø 4,5 mm (.18") .....7.743.023.000	
			Contacts page 136 • Assembly instructions page 147

Right Angle Panel Connector, Male Thread, rotatable		Type	Part Number
		<b>4 + 3 + PE, insert for pins</b> 4 holes Ø 4,5 mm (.18") .....7.743.043.000	
			Contacts page 136 • Assembly instructions page 147



Panel Connector, Male Thread, Single Hole Mounting		Type	Part Number
		<b>Front mounting, 2 + 3 + PE, insert for pins</b> Thread M 40 x 1,5 .....7.742.023.000	
			Contacts page 136 • Assembly instructions page 146

Panel Connector, Male Thread, Single Hole Mounting		Type	Part Number
		<b>Front mounting, 4 + 3 + PE, insert for pins</b> Thread M 40 x 1,5 .....7.742.043.000	
			Contacts page 136 • Assembly instructions page 146

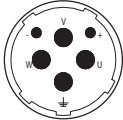
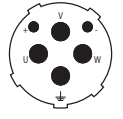
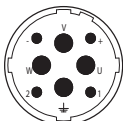
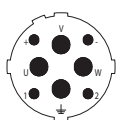
## Power Connectors Size 1,5 (M40) / Required Contacts

	Type of Contact	Contact Arrangement, Mating View
Insert for pins 2 + 3 + PE.....	2 x crimp pins 2 mm 4 x crimp pins 3,6 mm	
Insert for sockets 2 + 3 + PE .....	2 x crimp sockets 2 mm 4 x crimp sockets 3,6 mm	
Insert for pins 4 + 3 + PE.....	4 x crimp pins 2 mm 4 x crimp pins 3,6 mm	
Insert for sockets 4 + 3 + PE .....	4 x crimp sockets 2 mm 4 x crimp sockets 3,6 mm	

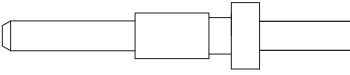
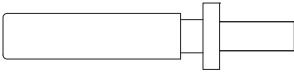
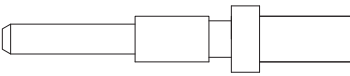
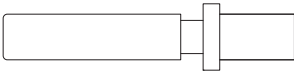
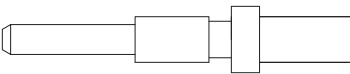
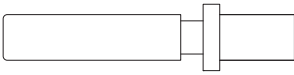

## Power Connectors Size 1,5 (M 40) / Contacts

Contacts	Type of Contact	Crimp Range	Part Number
	Crimp pin 2 mm, machined	.....0,5 – 4 mm <sup>2</sup> (AWG 20 – 12)	.....7.015.952.001
	Crimp socket 2 mm, machined	...0,5 – 4 mm <sup>2</sup> (AWG 20 – 12)	.....7.015.952.002
	Crimp pin 3,6 mm, machined	....1,5 – 4 mm <sup>2</sup> (AWG 16 – 12)	.....7.015.953.601
	Crimp socket 3,6 mm, machined	..1,5 – 4 mm <sup>2</sup> (AWG 16 – 12)	.....7.015.953.602
	Crimp pin 3,6 mm, machined	....6 mm <sup>2</sup> (AWG 10)	.....7.015.953.611
	Crimp socket 3,6 mm, machined	..6 mm <sup>2</sup> (AWG 10)	.....7.015.953.612
	Crimp pin 3,6 mm, machined	....10 mm <sup>2</sup> (AWG 8)	.....7.015.953.621
	Crimp socket 3,6 mm, machined	..10 mm <sup>2</sup> (AWG 8)	.....7.015.953.622

For appropriate setting of crimp tool see page 148



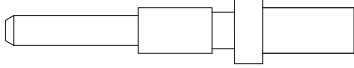





## Power Connectors Size 1,5 (M40) / Contacts

Type	Part Number	Contacts
Crimp pin 3,6 mm, machined .... 16 mm <sup>2</sup> (AWG 6) .....	7.015.953.631	
Crimp socket 3,6 mm, machined.. 16 mm <sup>2</sup> (AWG 6) .....	7.015.953.632	

Crimp Tool Settings see page 144

For appropriate setting of crimp tool see page 148

## Power Connectors Size 1,5 (M40) / Accessories

Accessories	Type	Part Number
	Plastic protective cap for connectors with female thread.....	7.000.900.152
	Plastic protective cap for connectors with male thread .....	7.000.900.151
	Brass protective cap for connectors with female thread.....	7.015.900.103
	Brass protective cap for connectors with male thread .....	7.015.900.102
	Brass protective cap with chain for connectors with female thread .....	7.015.9S1.003
	Brass protective cap with chain for connectors with male thread.....	7.015.9S1.002

## Power Connectors Size 1,5 (M40) / Accessories

Type	Part Number	Accessories
Adaptor flange for Straight Connectors .....	7.010.900.129	
Adapter for Conduit Fittings	Snapflex 25.....7.010.900.214 DN 23 .....7.010.900.215 Snapflex 32.....7.010.900.216 DN 29 .....7.010.900.217	
Crimp tool for manual crimping of machined crimp contacts up to 10 mm <sup>2</sup> (AWG 8) for power connectors .....	7.000.900.902	
See page 140 / 141 for crimp tool instructions and page 144 for proper setting		
Crimp tool for manual crimping of machined crimp contacts 16 mm <sup>2</sup> (AWG 6) .....	7.000.900.903	
See page 142 / 143 for crimp tool instructions and page 144 for proper setting		

# Crimp Tool for Power Connectors Size 1,5 (M 40)

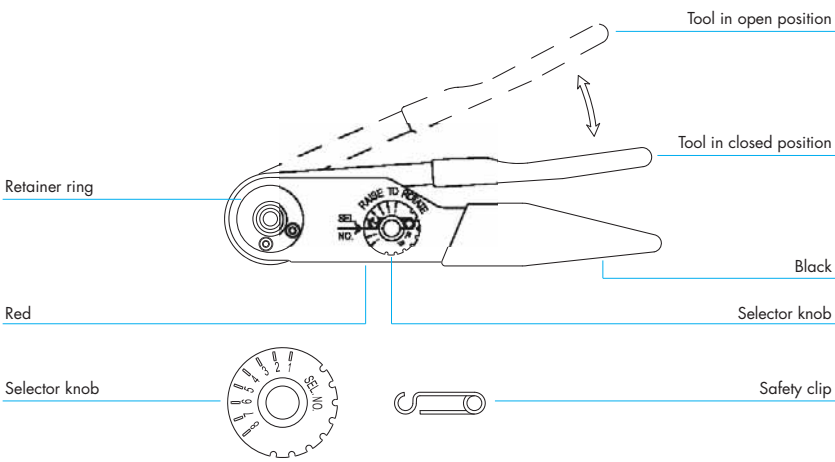
Crimp Tool	Type	Part Number
	<p>Crimp tool .....7.000.900.902</p> <p><b>Application</b> The four indent crimp tool 7.000.900.902 has been developed for optimal crimping of machined contacts with diameters from 1 to 10 mm<sup>2</sup> (18 through 8 AWG).</p> <p><b>How to Crimp</b> The reference table indicates the correct locator position to be selected and the crimp depth to be adjusted for the contact to be crimped. The contact is then inserted through the access hole of the tool on the opposite side of the locator. The contact is held in place by closing the handles to the first lock-in position thus preventing the contact from falling out of the tool and facilitating insertion of the wire into the contact. The precision ratchet assures consistently accurate crimping every time by forcing the tool to be closed all the way completing the crimping cycle before the tool can be opened again.</p> <p><b>Exchange of the Locator</b> The locator can be exchanged by removing the socket head cap screw with a socket wrench. It can then be disassembled from the hex head screw by turning it counter-clockwise.</p>	 <p>Retainer ring</p> <p>Red</p> <p>Selector knob</p> <p>Safety clip</p> <p>Tool in open position</p> <p>Tool in closed position</p> <p>Black</p> <p>Selector knob</p>

#### Setting Up Instructions

1. Tool must be in open position
2. Place selected single position head assembly onto retainer ring with alignment pin in alignment pin hole
3. After single position head is seated against retainer ring, tighten socket head screws with 9/64 inch socket head screw key
4. Refer to dataplate on single position head. From the proper wire size column, determine the selector number that corresponds with the contact being used
5. Remove spring clip lock wire from selector knob. Raise selector knob and rotate until selector number is in line with index mark. Replace spring clip lock wire (optional)

#### Crimping Instructions

1. Insert contact and prepared wire through the indenter opening into positioner
2. Squeeze handles together until ratchet releases. Handle will return to open position. Remove crimped contact and wire

#### Removing Single Position Head

Loosen socket head screws until threads are disengaged from retainer ring and remove with a straightlifting motion

#### Gaging Instructions

The correct function of the crimp tool has to be checked with a gage (item no. 7.010.900.117).

#### „GO“-Gaging (green)

Operate tool to fully closed position. Maintain firm hand pressure on the tool handles. Insert „GO“ gage end. Gage must pass freely between indenter tips.

#### „NO-GO“-Gaging (red)

Operate tool to fully closed position. Maintain firm hand pressure on the tool handles. Insert „NO-GO“ gage end. The „NO-GO“ gage may partially enter the indenter opening, but must not pass completely through the opening.

#### Care of Tool

There is virtually no maintenance required. However, it is a good practice to keep indenter tips free of residual color band deposits and other debris. A small wire brush may be used for this purpose.

#### We strongly recommend that you:

1. Do not immerse tools in cleaning solution
2. Do not spray oil into tool to lubricate
3. Do not attempt to disassemble tool or make repairs

This is a precision crimp tool and should be handled as such.

## Crimp Tool for Power Connectors Size 1,5 (M 40)

Crimp Tool	Type	Part Number
	<p>Crimp tool for contacts 16 mm<sup>2</sup> (AWG 6) ..... 7.000.900.903</p> <p><b>Application</b> The hand crimp tool 7.000.900.903 has been developed for optimal crimping of a large variety of connectors and terminals by using different interchangeable crimping dies.</p> <p><b>Operation</b></p> <ul style="list-style-type: none"> <li>- Select crimp insert and install in tool</li> <li>- Insert and align crimp contact in tool</li> <li>- Compress tool until contact is held in place</li> <li>- Insert conductor into contact</li> <li>- Fully compress tool (tool will reopen automatically)</li> <li>- Remove crimped conductor from tool</li> </ul>	 <p>Die retaining screws</p> <p>Emergency release</p> <p>Stationary jaw with upper die</p> <p>Movable jaw with lower die</p> <p>Set screw</p> <p>Adjustment wheel</p>

## Crimp Tool for Power Connectors Size 1,5 (M 40)

### Crimp Tool

#### Adjustment of crimp force and height

Crimp force adjustment is done in the factory (120 – 180N when unloaded). Tool frame and jaws are connected that way, an optimal crimping result will be obtained based on the hand force indicated above. In case the result (e.g. crimp height, pull-out force, etc.) does not meet the requirements of the plug manufacturer, the following reasons can be considered:

#### a) Normal wear of tool

Readjustment possible

#### b) Worn dies

Dies have to be replaced

**The quality personnel is authorized to control and readjust these parameters as described below:**

- Unscrew the set screw by means of a screw driver
- Rotating the adjustment wheel anticlockwise, the crimp force increases and the crimp height decreases (+)
- Rotating the adjustment wheel lockwise, the crimp force decreases and the crimp height increases (-)
- When readjusting the hand force shall not exceed 180N
- Before using the tool, the operator has to check the adjustment wheel being firmly secured by the set screw

#### Maintenance

Keep the tool clean and properly stored when not in service. The joints need to be regularly oiled and the circlips securing the bolts have to be always in place. Never use abrasives or hard material to clean the jaws. Please contact the manufacturer when the tool needs to be repaired or in case of readjustment problems.



## Crimp Tool for Power Connectors Size 1,5 (M 40)

### Crimp Tool Setting for HUMMEL Crimp Contacts (Crimp Tool 7.000.900.902)

Part Number	Contact	Cross Section mm <sup>2</sup>	AWG	Crimp Tool Setting mm	Locator Setting
7.015.952.001	Crimp pin 2 mm	1	17	2	3
		1,5	16	3	3
		2,5	14	4	3
		4	12	4	3
7.015.952.002	Crimp socket 2 mm	1	17	2	1
		1,5	16	3	1
		2,5	14	4	1
		4	12	4	1
7.015.953.601	Crimp pin 3,6 mm	1,5	16	3	2
		2,5	14	4	2
		4	12	5	2
7.015.953.602	Crimp socket 3,6 mm	1,5	16	3	4
		2,5	14	4	4
		4	12	5	4
7.015.953.611	Crimp pin 3,6 mm	6	10	5	2
7.015.953.612	Crimp socket 3,6 mm	6	10	5	4
7.015.953.621	Crimp pin 3,6 mm	10	8	7	2
7.015.953.622	Crimp socket 3,6 mm	10	8	7	4

These values are only guidelines and actual conductor cross sections depend on manufacturer tolerances.  
 Assembly information see page 148

### Crimp Tool Setting for HUMMEL Crimp Contacts (Crimp Tool 7.000.900.903)

Part Number	Crimp Contact	Cross Section mm <sup>2</sup>	AWG	Crimp Tool Setting
7.015.953.631	Crimp pin 3,6 mm	16	6	die 16
7.015.953.632	Crimp socket 3,6 mm	16	6	die 16

These values are only guidelines and actual conductor cross sections depend on manufacturer tolerances.  
 Assembly information see page 148



## Power Connectors Size 1,5 (M40) / Assembly Instructions

### Straight Connector, Female Thread / Male Threaded Connector

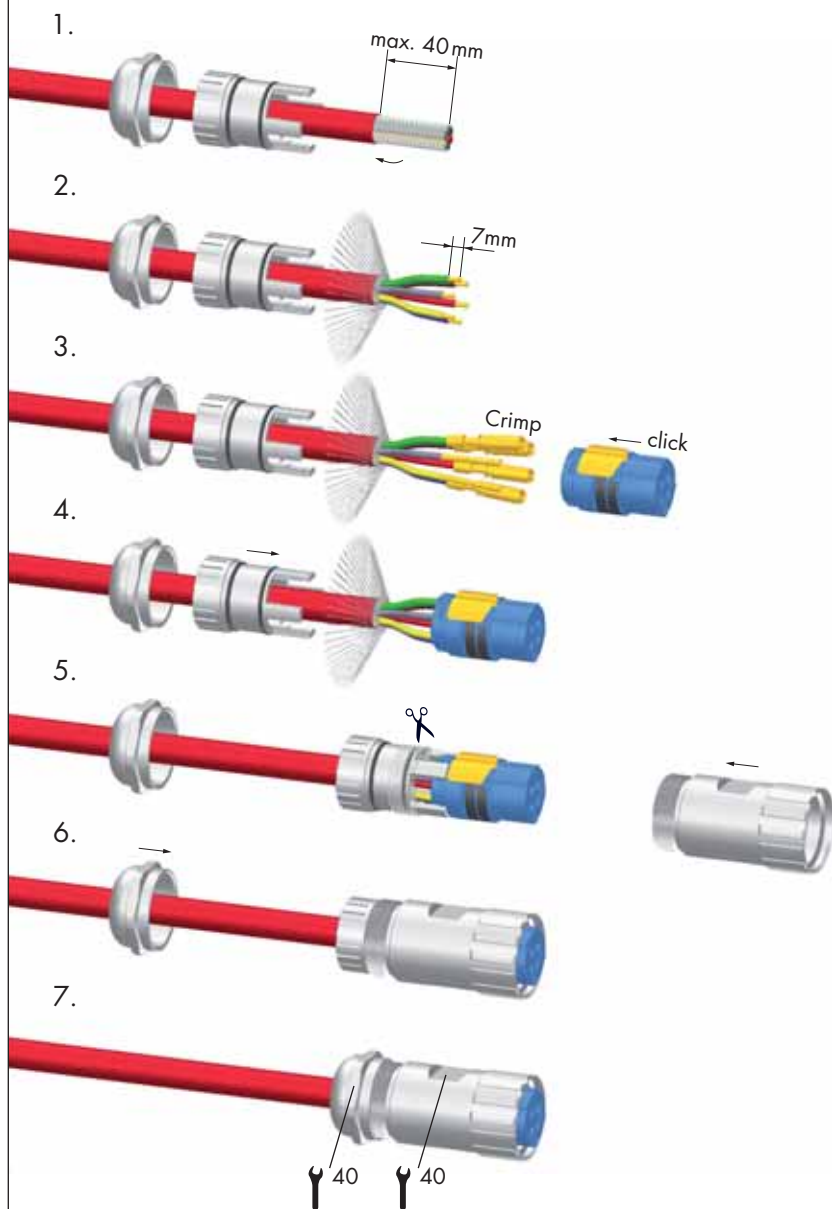

## Panel Connector

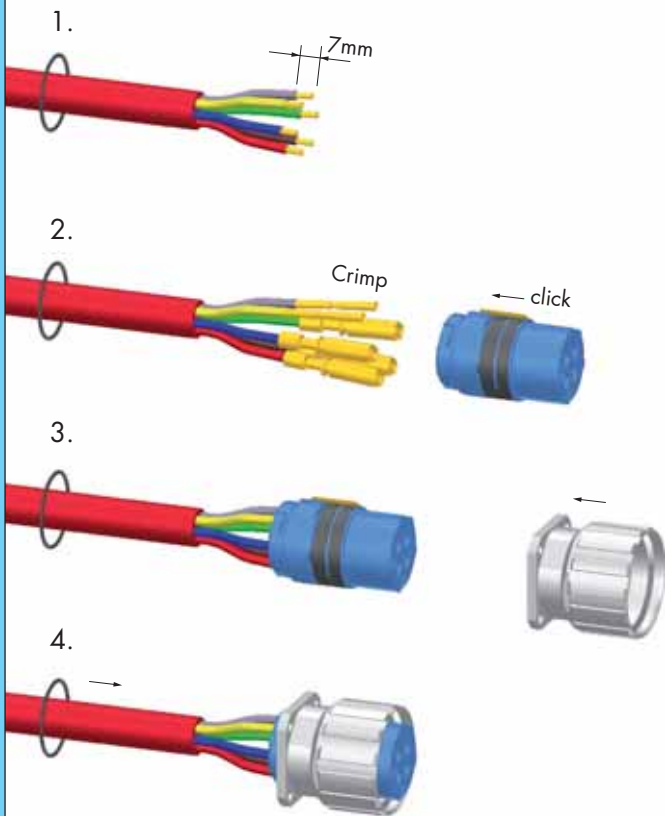

# Power Connectors Size 1,5 (M40) / Assembly Instructions

## Right Angle Panel Connector

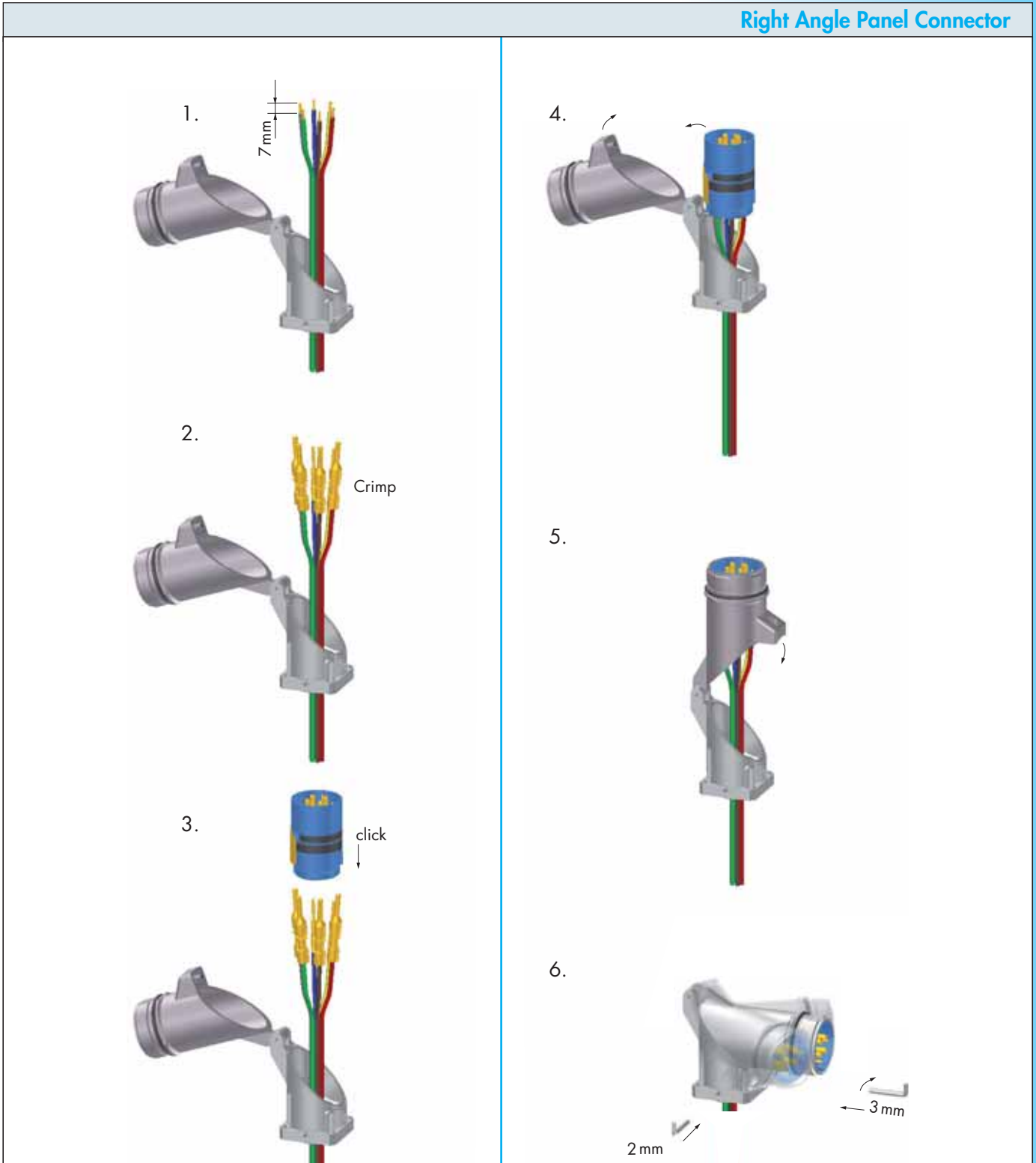

## Crimping, Assembly and Disassembly

### Crimping, Assembly and Disassembly

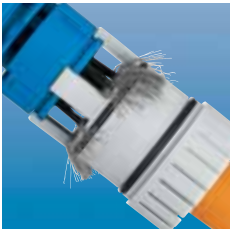

#### Crimping

- Strip wire ends 7 mm (.28")
- Dial appropriate setting of crimp tool (page 144)
- Push crimp contact into opening of crimping tool
- Insert stripped wire into the funnel shaped end of the crimp contact
- Squeeze handles of crimping tool together connect contact to wire

#### Assembly

- Remove crimped assembly and pull on wire to test connection
- Push into desired position of insert  
Note: It is recommended to assemble the large contacts first.

#### Disassembly of Contacts from Insert

A small screwdriver is needed to remove the contacts from the insert.

- Release the white ring by a screwdriver out of the insert
- Move the misplaced contacts out of the insert
- Enter the ring back into the insert
- Push the contacts back into insert

#### Shielding

- Assemble strain relief insert with insert
- Fold stranding of the shield back over the first O-Ring of the strain relief insert
- Cut back the overextending braid



The stranding of the shield is not allowed to touch the second O-Ring. Otherwise the assembly may not be proof.

# Push-Pull Technology



Housings

page 152



Inserts

page 22, 74, 114, 132

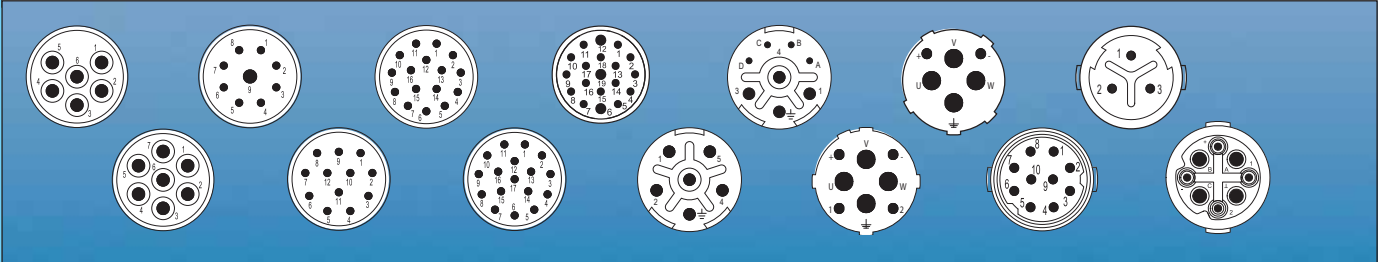

Accessories

page 28, 59, 82, 116, 138



## Push-Pull Connectors

Mechanical Data	Materials and Technical Data
Housing	Copper-Zinc alloy Die Casting Aluminium alloy
Housing surface	Nickel plated, other surface upon request
Inserts (for contacts)	Thermoplastic Polyamid PA 6 (Nylon 6/6), PBT Fire protection class V-0
Contacts	Brass Alloy
Contact surface at point of contact	Nickel and gold plated (0,25 µm Au)
Minimum mating cycles	> 250
Seals / O-Rings	Buna-N standard optional Viton® (Viton is a registered trademark of DuPont)
Temperature range	-40° C – 125° C (-40 °F – 257 °F)
Type of contacts M 16	Crimp, dip-solder (PCB)
Type of contacts signal M 23	Crimp, solder, dip-solder (PCB)
Type of contacts power M 23, M 40	Crimp
Protection	IP 67 / IP 69K per EN 60 529 (connected), NEMA 4x

## Additional Information

### Electrical data see standard program

Connectors M 16	page 17
Signal Connectors M 23	page 65
Power Connectors M 23	page 107
Power Connectors Size 1,5	page 131

### Inserts and contacts see standard program

Connectors M 16	page 22
Signal Connectors M 23	page 74
Power Connectors M 23	page 114
Power Connectors Size 1,5	page 132



We do not recommend disconnecting or connecting HUMMEL Connectors under load.

## Characteristics

### HUMMEL Push-Pull Connectors guarantee:

- Quick connecting cycle
- EMC compatible connection due to radially locked metal ring
- High protection rate
- Easy connection / disconnection even under tight space conditions
- Best reliability with optional safety ring



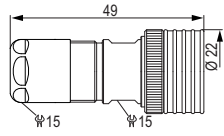

Standard delivery of M 40 (size 1.5) Power Connector include Contact Insert

## M 16 Signal Connectors / Push-Pull

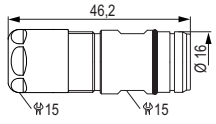
Straight Connector, Female Thread		Cable-Ø	Part Number
 	2 – 7 mm (.08 – .28")	7.813.300.000	
	4 – 9 mm (.16 – .35")	7.813.400.000	
		<b>Optional:</b> Safety ring	
Contacts and inserts page 22 • Assembly instructions page 34			

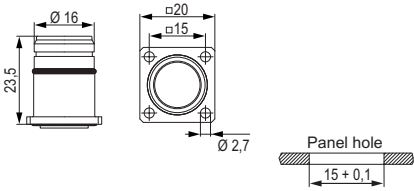
Straight Connector, Male Thread		Cable-Ø	Part Number
 	2 – 7 mm (.08 – .28")	7.823.300.000	
	4 – 9 mm (.16 – .35")	7.823.400.000	
Contacts and inserts page 22 • Assembly instructions page 34			

Panel Connector, Male Thread		Cable-Ø	Part Number
 	4 holes Ø 2,7 mm (.11")	7.840.300.000	
	Contacts and inserts page 22 • Assembly instructions page 38		

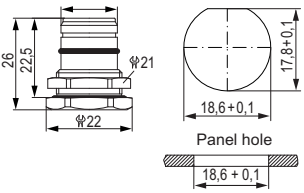
Panel Connector, Male Thread		Cable-Ø	Part Number
 	<b>Rear mounting, single hole mounted</b> Including jam nut	7.850.300.000	
	Contacts and inserts page 22 • Assembly instructions page 38		



## Signal Connectors M 23/ Push-Pull

Cable-Ø	Part Number	Straight Connector, Female Thread	
3 – 7 mm (.12 – .28")	7.156.400.000		
7 – 12 mm (.24 – .47")	7.156.500.000		
11 – 17 mm (.43 – .67")	7.156.600.000		
<b>Optional:</b> Safety ring			
Contacts and inserts page 74 • Assembly instructions page 87			

Cable-Ø	Part Number	Right Angle Connector, Female Thread	
3 – 7 mm (.12 – .28")	7.304.300.000		
5 – 10 mm (.20 – .39")	7.304.400.000		
7 – 12 mm (.24 – .47")	7.304.500.000		
10 – 14 mm (.39 – .55")	7.304.600.000		
<b>Optional:</b> Safety ring			
Contacts and inserts page 74 • Assembly instructions page 88			

Cable-Ø	Part Number	Right Angle Connector, Female Thread, EMC	
3 – 7 mm (.12 – .28")	7.305.300.000		
5 – 10 mm (.20 – .39")	7.305.400.000		
7 – 12 mm (.24 – .47")	7.305.500.000		
10 – 14 mm (.39 – .55")	7.305.600.000		
<b>Optional:</b> Safety ring			
Contacts and inserts page 74 • Assembly instructions page 88			

Signal Connectors M 23 Push-Pull fit to all housings with male thread of the standard series HUMMEL Signal Connectors M 23

## Signal Connectors M 23 / Push-Pull

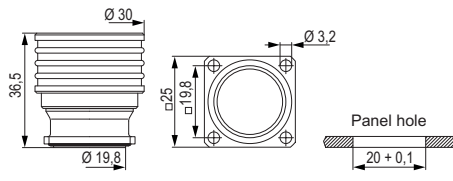
Panel Connector, Female Thread, with knurled Nut		Type	Part Number
		<b>Without coding option</b> 4 holes $\varnothing$ 3,2 mm (.13") .....7.440.500.000	
		<b>Optional:</b> Safety ring	
		Contacts and inserts page 74 • Assembly instructions page 90	

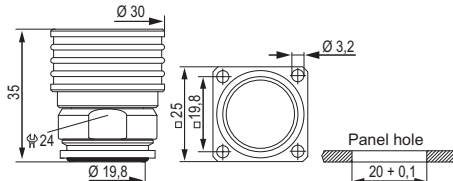
Panel Connector, Female Thread, with knurled Nut		Type	Part Number
		<b>With coding option</b> 4 holes $\varnothing$ 3,2 mm (.13") .....7.448.500.000	
		<b>Optional:</b> Safety ring	
		Contacts and inserts page 74 • Assembly instructions page 90	

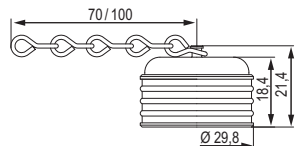
Protective Caps, Push-Pull Signal		Type	Part Number
		<b>For signal connectors with male thread</b> .....7.010.950.102	
		<b>with chain 100 mm</b> .....7.010.95S.102	

Signal Connectors M 23 Push-Pull fit to all housings with male thread of the standard series HUMMEL Signal Connectors M 23

## Signal Connectors M 23 / Push-Pull

Cable-Ø	Part Number	Straight Connector, Female Thread	
7 – 12 mm (.24 – .47")	.....7.555.500.000		
11 – 17 mm (.43 – .67")	.....7.555.600.000		
<b>Optional:</b> Safety ring			
<small>Contacts and inserts page 114 • Assembly instructions page 122</small>			

Cable-Ø	Part Number	Right Angle Connector, Female Thread	
7 – 12 mm (.24 – .47")	.....7.575.500.000		
10 – 14 mm (.39 – .55")	.....7.575.600.000		
<b>Optional:</b> Safety ring			
<small>Contacts and inserts page 114 • Assembly instructions page 124</small>			

Power Connectors M 23 Push-Pull fit to all housings with male thread of the standard series HUMMEL Power Connectors M 23

## Power Connectors Size 1,5 / Push-Pull

Straight Connector, Female Thread		Cable-Ø	Part Number
			<b>2 + 3 + PE, insert for sockets</b> 13 – 18 mm (.52 – .71").....7.715.623.000 17 – 24 mm (.67 – .95").....7.715.723.000 21 – 28 mm (.83 – 1.10")...7.715.823.000
			<b>Optional:</b> Safety ring  Contacts page 136 • Assembly instructions page 145

Straight Connector, Female Thread		Cable-Ø	Part Number
			<b>4 + 3 + PE, insert for sockets</b> 13 – 18 mm (.52 – .71").....7.715.643.000 17 – 24 mm (.67 – .95").....7.715.743.000 21 – 28 mm (.83 – 1.10")...7.715.843.000
			<b>Optional:</b> Safety ring  Contacts page 136 • Assembly instructions page 145

## Power Connectors Size 1,5 / Push-Pull

Cable-Ø	Part Number	Straight Connector, Male Thread	
<b>2+3+PE, insert for pins</b> 13 – 18 mm (.52 – .71").....7.725.623.000 17 – 24 mm (.67 – .95").....7.725.723.000 21 – 28 mm (.83 – 1.10")...7.725.823.000			
Contacts page 136 • Assembly instructions page 145			

Cable-Ø	Part Number	Straight Connector, Male Thread	
<b>4+3+PE, insert for pins</b> 13 – 18 mm (.52 – .71").....7.725.643.000 17 – 24 mm (.67 – .95").....7.725.743.000 21 – 28 mm (.83 – 1.10")...7.725.843.000			
Contacts page 136 • Assembly instructions page 145			

Panel Connector	Type	Part Number
	<p><b>2 + 3 + PE, insert for pins</b> 4 holes Ø 4,5 mm (.18") .....7.740.523.000</p>	
<p>Contacts page 136 • Assembly instructions page 146</p>		

Panel Connector	Type	Part Number
	<p><b>4 + 3 + PE, insert for pins</b> 4 holes Ø 4,5 mm (.18") .....7.740.543.000</p>	
<p>Contacts page 136 • Assembly instructions page 146</p>		

## Stainless Steel Connectors (INOX)



Housings

page 162



Inserts

page 74, 114

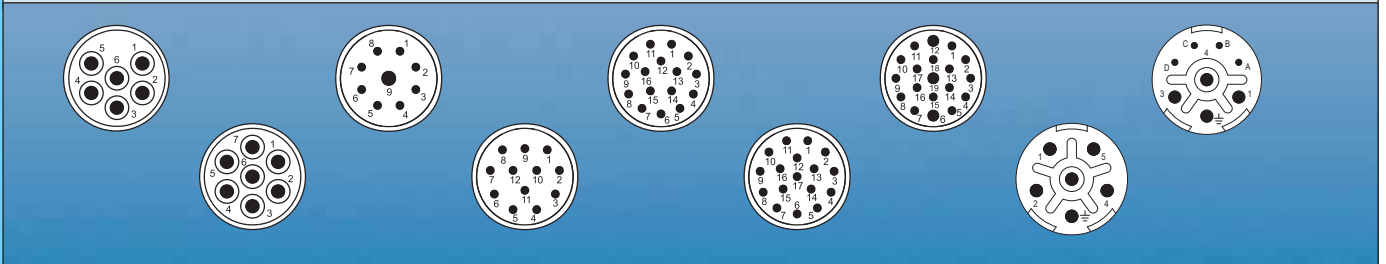

Accessories

page 82, 116





## M 23 Connectors Stainless Steel (INOX)

Mechanical Data	Materials and Technical Data	
Housing	Stainless Steel V4A	1.4404 (AISI 316 L)
Housing surface	Clear	
Inserts (for contacts)	Thermoplastic Polyamid PA 6 (Nylon 6/6), PBT	Fire protection class V-0
Contacts	Brass Alloy	
Contact surface at point of contact	Nickel and gold plated (0,25 µm Au)	
Minimum mating cycles	> 1000	
Seals / O-Rings	Viton (FPM), alternativ EPDM	
Temperature range	-40° C – 125° C	
Type of contacts signal M23	Crimp, solder, dip-solder (PCB)	
Type of contacts power M23	Crimp	
Protection	IP 67 / IP 69K per EN 60 529 (connected), NEMA 4x	
Cable diameter range signal connectors	3 – 14 mm (.12 – .55")	
Cable diameter range power connectors	7 – 17 mm (.24 – .67")	

## Additional Information

### Electrical data see standard program

Signal Connectors M23 page 65  
 Power Connectors M23 page 107

### Inserts and contacts see standard program

Signal Connectors M23 page 74  
 Power Connectors M23 page 114

We do not recommend disconnecting or connecting HUMMEL Connectors under load.

## Typical Applications



## Signal Connectors / Stainless Steel (INOX)

### Straight Connector, Female Thread

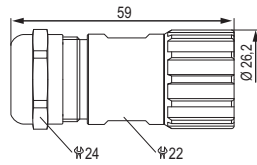

#### Cable-Ø

#### Part Number

3 – 7 mm (.12 – .28")	7.140.300.000
5 – 10 mm (.20 – .39")	7.140.400.000
7 – 12 mm (.24 – .47")	7.140.500.000
10 – 14 mm (.39 – .55")	7.140.600.000

Contacts and inserts page 74 • Assembly instructions page 166

Assembly tool 7.010.900.127 is required

### Straight Connector, Female Thread, EMC

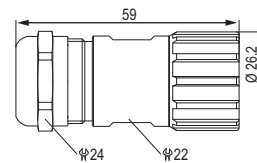

#### Cable-Ø

#### Part Number

3 – 7 mm (.12 – .28")	7.141.300.000
5 – 10 mm (.20 – .39")	7.141.400.000
7 – 12 mm (.24 – .47")	7.141.500.000
10 – 14 mm (.39 – .55")	7.141.600.000

Contacts and inserts page 74 • Assembly instructions page 166

Assembly tool 7.010.900.127 is required

### Straight Connector, Male Thread

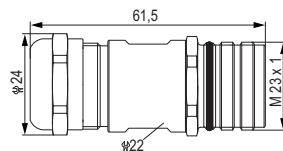

#### Cable-Ø

#### Part Number

3 – 7 mm (.12 – .28")	7.240.300.000
5 – 10 mm (.20 – .39")	7.240.400.000
7 – 12 mm (.24 – .47")	7.240.500.000
10 – 14 mm (.39 – .55")	7.240.600.000

Contacts and inserts page 74

### Straight Connector, Male Thread, EMC

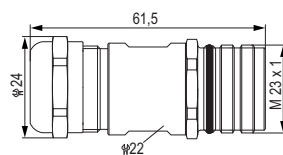

#### Cable-Ø

#### Part Number

3 – 7 mm (.12 – .28")	7.241.300.000
5 – 10 mm (.20 – .39")	7.241.400.000
7 – 12 mm (.24 – .47")	7.241.500.000
10 – 14 mm (.39 – .55")	7.241.600.000

Contacts and inserts page 74

## Signal Connectors / Stainless Steel (INOX)

Type	Part Number	Panel Connector, Male Thread
<b>With anti-vibration O-Ring</b> 4 holes $\varnothing$ 3,2 mm (.13").....7.410.400.000		
Contacts and inserts page 74 • Assembly instructions page 91 / 92		

Type	Part Number	Right Angle Panel Connector, Male Thread
4 holes $\varnothing$ 2,7 mm (.11").....7.430.400.000		
Contacts and Inserts page 74		

## Power Connectors / Stainless Steel (INOX)

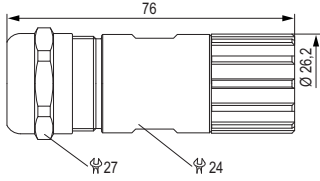
Straight Connector, Female Thread		Cable-Ø	Part Number
		7 – 12 mm (.24 – .47").....7.554.500.000	
		11 – 17 mm (.43 – .67").....7.554.600.000	
		Contacts and inserts page 114 • Assembly instructions page 122	

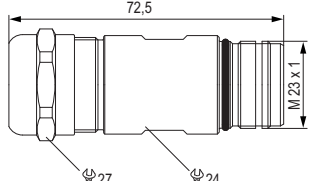
Straight Connector, Male Thread		Cable-Ø	Part Number
		7 – 12 mm (.24 – .47").....7.564.500.000	
		11 – 17 mm (.43 – .67").....7.564.600.000	
		Contacts and inserts page 114 • Assembly instructions page 122	

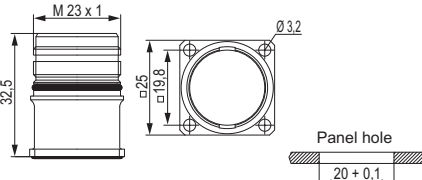
Panel Connector, Male Thread		Type	Part Number
		<b>For front mounting</b> 4 holes Ø 3,2 mm (.13").....7.601.400.000	
		<b>Optional:</b> Flat gasket	
		Contacts and inserts page 114 • Assembly instructions page 123	

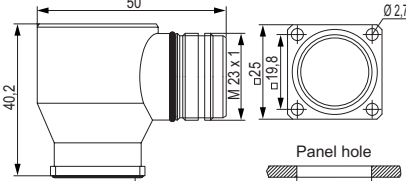
Right Angle Panel Connector, Male Thread		Type	Part Number
		4 holes Ø 2,7 mm (.11").....7.630.400.000	
		Contacts and Inserts page 114	

## Stainless Steel Connectors (INOX) / Accessories

Type	Part Number	Accessories
Assembly tool .....	7.010.900.127	
Plastic protective cap for connectors with male thread .....	7.000.900.101	
for connectors with female thread.....	7.000.900.102	
Stainless steel protective cap for connectors with female thread.....	7.010.904.103	
Stainless steel protective cap with rope for connectors with female thread .....Length 100 mm .....	7.010.9S4.103	
Stainless steel protective cap for connectors with male thread .....	7.010.904.102	
Stainless steel protective cap with rope for connectors with male thread .....Length 100 mm .....	7.010.9S4.102	
Crimp tool for manual crimping of machined crimp contacts for signal connectors .....	7.000.900.901	

Operating instructions on page 85

## Straight Signal Connector, Female Thread

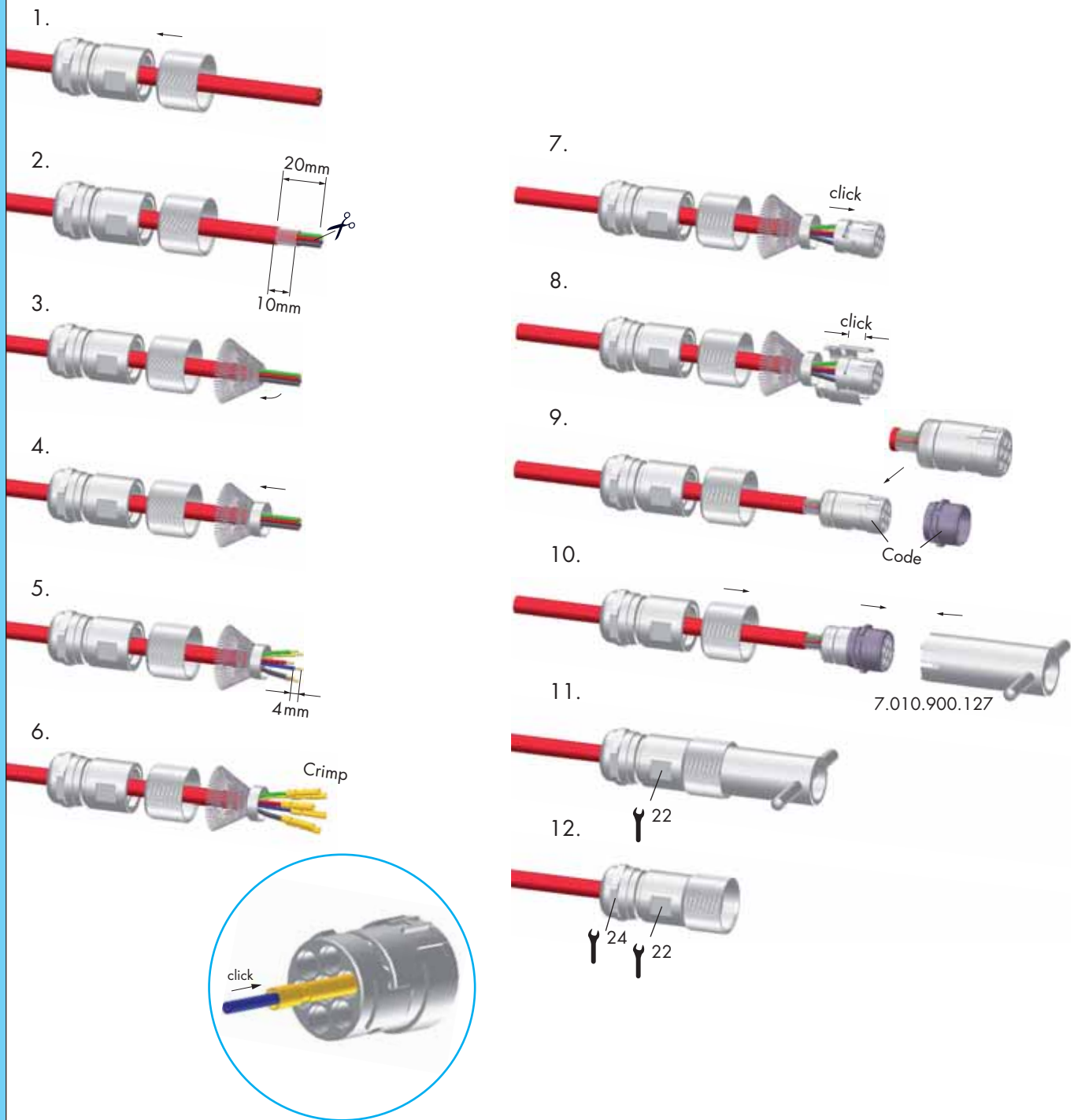

## Moulded Cordsets M 23



Housings

page 170



Inserts

page 74 and page 114 respectively

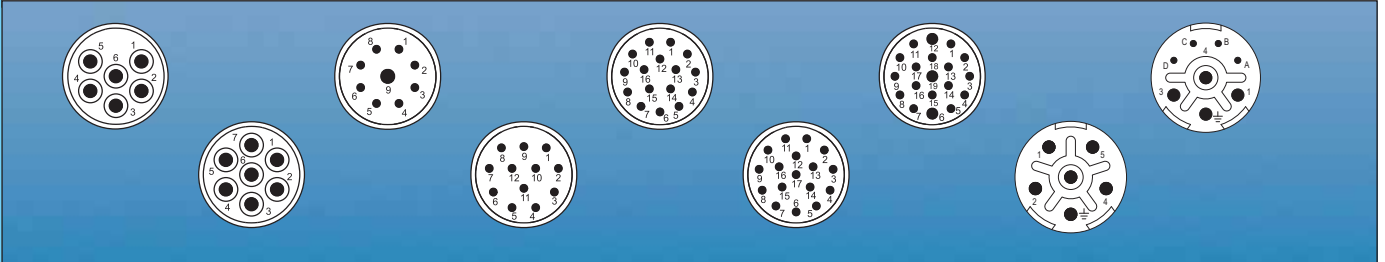

Accessories

page 82 and page 116 respectively





## Moulded Connector Cordsets

Mechanical Data	Materials and Technical Data
Housing	Copper-Zinc alloy Die Casting
Moulded strain relief	Polyurethan PUR
Housing surface	Nickel plated brass, black strain relief
Inserts (for contacts)	Thermoplastic Polyamid PA 6 (Nylon 6/6), PBT Fire protection class V-0
Contacts	Brass Alloy
Contact surface at point of contact	Nickel and gold plated (0,25 µm Au)
Minimum mating cycles	> 1000
Seals / O-Rings	Buna-N standard optional Viton® (Viton is a registered trademark of DuPont)
Temperature range	-40° C – 125° C (-40 °F – 257 °F)
Type of contacts	Crimp
Protection	IP 67 / IP 69 K per EN 60 529 (connected), NEMA 4x
Cable diameter range	5 – 15 mm (.20" – .60")
Cable style	Cable specifications available upon request
Labelling	HUMMEL logo as standard, other options available upon request

## Additional Information

### Electrical data see standard program

Signal Connectors M23 page 65  
Power Connectors M23 page 107

### Inserts and contacts see standard program

Signal Connectors M23 page 74  
Power Connectors M23 page 114



We do not recommend disconnecting or connecting HUMMEL Connectors under load.

## Other versions



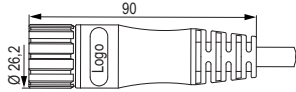

Moulded connector cordsets are also available as Push-Pull- or Stainless-Steel (Inox)-Versions.

## Moulded Connector Cordsets M23

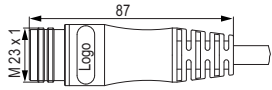

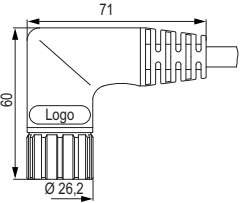
Straight Connector, Female Thread		Type	Inserts
		Standard / EMC	Pins or sockets

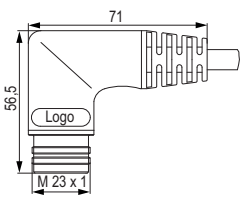

Straight Connector, Male Thread		Type	Inserts
		Standard / EMC	Pins or sockets

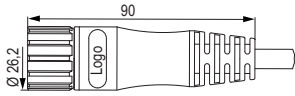

Right Angle Connector, Female Thread		Type	Inserts
		Standard / EMC	Pins or sockets

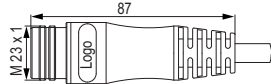

Right Angle Connector, Male Thread		Type	Inserts
		Standard / EMC	Pins or sockets

## Moulded Connector Cordsets M 23

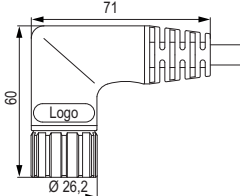
Type	Inserts	Straight Connector, Female Thread	
Standard / EMC .....	Pins or sockets		

Type	Inserts	Straight Connector, Male Thread	
Standard / EMC .....	Pins or sockets		

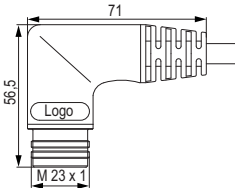
Type	Inserts	Right Angle Connector, Female Thread	
Standard / EMC .....	Pins or sockets		

Type	Inserts	Right Angle Connector, Male Thread	
Standard / EMC .....	Pins or sockets		

### IP 67 – liquid tight when disconnected



Using a rubber diaphragm makes this connector liquid tight either connected or disconnected (NEMA 4 = IP 67).

### Bulkhead Connector



Bulkhead connectors accept plugs on both sides. They are rugged, liquid tight and available in all number of poles.

### Simple EMI / RFI shielding



An integrated metalized EMI clamping insert grounds to the braid significantly simplifying the assembly of the elbow connector.

### MULTI Seal Connector



A large selection of standard MULTI seal inserts allow strain relief of several individual conductors on one single connector.

### Flexible Cable Protection



In addition to the integrated strain relief, the flex nut adds kink protection to a cable - available for all connector sizes.

### Adaptor flange



To secure loose connections, an adaptor flange can be attached to a straight connector.

### 12-point hex and knurled nut



This special nut makes connection simple by either tightening the connector manually (knurled nut) or with a wrench (12-point hex).

### Conduit Attachment



Flexible corrugated conduit can be attached to a connector with an adapter offering strain relief and cable protection as well.

### Connector with specific pull-out resistance



After reaching a certain pull-out force the connection releases preventing damage to the device (apparatus).

### Bulkhead Fitting



This fitting with oversized flange is commonly used in the ship building industry where Signal Connections have to be maintained under extreme conditions.

### Captive Protective Cap



The metal protective cap is secured to a cable by a safety ring and stays attached in open connections.

### ANACONDA Conduit Adapter



HUMMEL offers custom adapters for ANACONDA conduit systems in hazardous locations.

### Distribution-box



Distribution-boxes are known as important components for applications in automation. Robust and fully wired they are done according to customers specification.

### Coloured Overmould



Completing a design or showing technical functions, overmould could be made in different colours too (e.g. DESINA green RAL 6018).

### Derating M 16

Straight connectors male + female, 10 pole,  
wires 10 x AWG 18

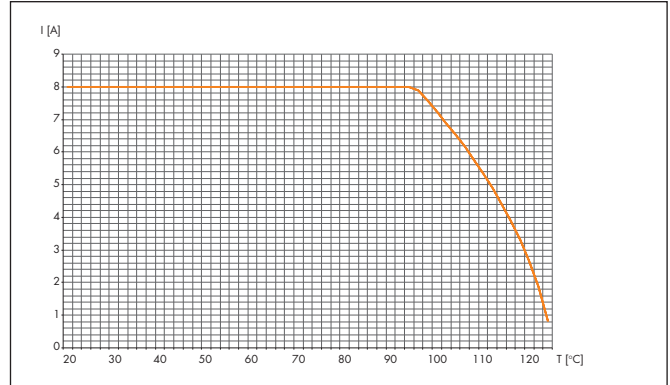

### Derating M 16 TWINTUS

TWINTUS and straight connector female M 16  
4+3+PE, wires AWG 14 (Power)  
10pole, wires AWG 26

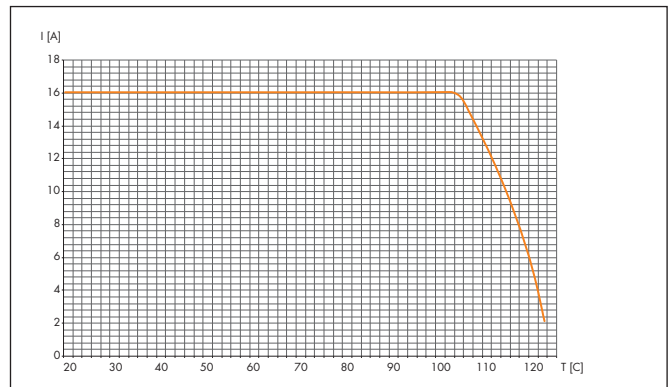

### Derating M 23 Signal

Straight Connectors male + female,  
wires 12 x AWG 17

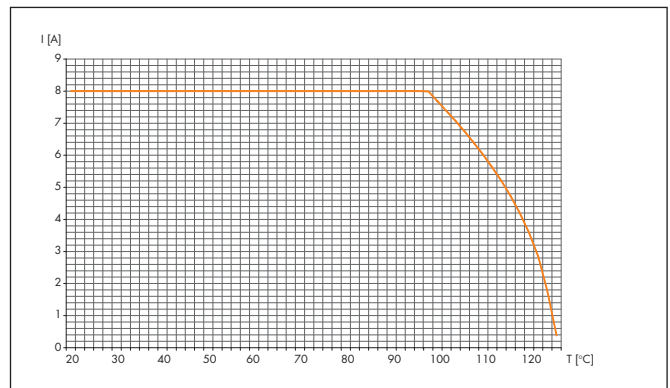



## Derating M23 Power

Straight connectors male + female M23, 5 + PE,  
wires 5 x AWG 12

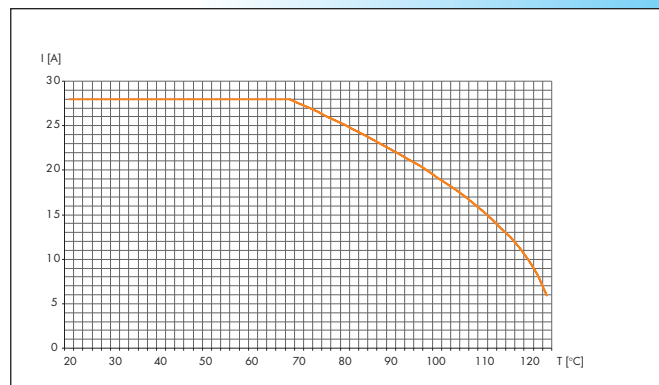

## Derating M40 (Size 1,5)

Straight connectors male + female,  
wires 3 x AWG 6

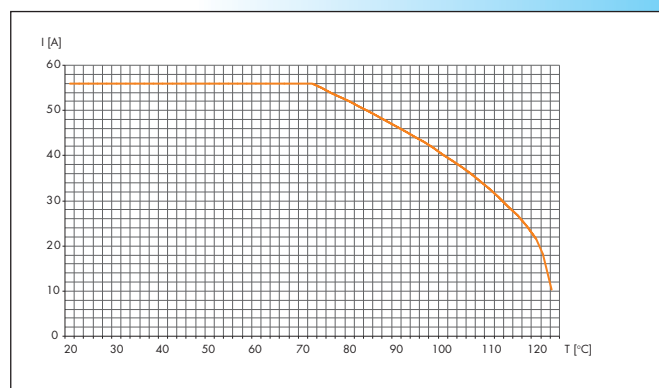

Page Finder

Part Number	Page	Part Number	Page	Part Number	Page	Part Number	Page
7.000.900.101	136	7.000.900.163	28	7.140	160	7.589	107
49/57/80/114/163		7.000.900.167	99	7.141	160	7.601	107
7.000.900.102	136	7.010.900.168	99	7.156	151	7.601.4	162
49/57/80/114/163		7.010.900.169	99	7.206	64	7.605	107
7.000.900.151	136	7.010.900.170	99	7.208	42	7.621	108
7.000.900.152	136	7.010.900.183	49	7.210	96	7.623	108
7.000.900.901	99/115/163	7.010.900.200	29	7.240	160	7.626	108
7.000.900.902	137	7.010.900.201	29	7.241	160	7.630.4	162
7.000.900.903	137	7.010.900.202	29	7.300	65	7.635	110
7.000.900.904	29/81	7.010.900.203	29	7.301	65	7.636	110
7.000.900.906	50	7.010.900.204	29	7.304	151	7.637	110
7.000.900.907	50	49/58/81/115		7.305	151	7.638	110
7.000.980.16	28	7.010.900.205	29	7.306	65	7.638.1	110
7.000.980.167	99	49/58/81/115		7.308	42	7.641	107
7.000.980.168	99	7.010.900.206	29	7.350	65	7.645	107
7.000.9DM.C03	81	49/58/81/115		7.400	66	7.651	108
7.000.9DM.C04	81	7.010.900.207	29	7.402	66	7.653	111
7.000.9DM.C06	115	49/58/81/115		7.404	66	7.661	111
7.000.9DM.C07	115	7.010.900.208	29	7.406	66	7.681	111
7.001.903	22	49/58/81/115		7.408	42	7.683	111
7.001.906	72	7.010.900.209	29	7.410.0	66	7.710	130
7.001.907	72	49/58/81/115		7.410.4	161	7.715	154
7.001.910	23	7.010.900.214	137	7.410.7	96	7.720	130
7.001.912	74	7.010.900.215	137	7.412	66	7.725	155
7.001.916	75	7.010.900.216	137	7.414	66	7.740.0	131
7.001.917	75	7.010.900.217	137	7.416	66	7.740.5	156
7.001.919	76	7.010.900.129	137	7.420	67	7.742	132
7.001.920	44	7.010.901.001	26/78	7.421	67	7.743	132
7.001.926	97	7.010.901.002	26/44/78	7.422	67	7.744	131
7.001.928	97	7.010.901.012	26/44/78	7.423	67	7.810	18
7.001.943	23	7.010.901.021	78	7.425	67	7.813	150
7.001.981	73	7.010.901.022	44/78	7.430.4	161	7.820	18
7.001.983	22	7.010.901.031	78	7.431	68	7.823	150
7.001.985	24	7.010.901.5	78	7.432	68	7.830	19
7.001.988	24	7.010.902.0	79	7.433	68	7.831	19
7.002.912	74	7.010.904.102	163	7.433.1	68	7.840	20
7.002.917	76	7.010.904.103	163	7.435	68	7.840.3	150
7.002.981	73	7.010.94	113	7.440.0	66	7.842	20
7.003.903	22	7.010.950.102	152	7.440.5	152	7.843	20
7.003.906	72	7.010.955.102	152	7.444	66	7.845	21
7.003.907	72	7.010.971	98	7.448.0	66	7.847	19
7.003.910	23	7.010.980.6	44	7.448.5	152	7.850.0	21
7.003.912	74	7.010.980.8	26	7.449	66	7.850.3	150
7.003.916	75	7.010.981	26	7.450	69	7.852	19
7.003.917	75	7.010.982	27	7.452	69	7.810.4	54
7.003.919	76	7.010.950.702	29	7.454	69	7.820.4	54
7.003.920	44	49/57/80/114		7.456	69	7.840.0	54
7.003.926	97	7.010.950.703	57/80/114	7.458	69	7.841.0	54
7.003.943	23	7.010.950.704	28	7.459	69	7.842.0	55
7.003.981	73	7.010.950.705	28	7.460	69	7.850.0	55
7.003.983	22	7.010.950.707	99	7.462	69	7.843.0	55
7.003.985	24	7.010.950.708	99	7.464	69	7.845.0	55
7.003.988	24	7.010.950.783	49	7.466	69	7.852.4	56
7.004.912	74	7.010.951.002	29	7.468	43	7.847.4	56
7.004.917	76	49/57/80/114		7.476	64	7.101	71
7.004.981	73	7.010.951.003	57/80/114	7.486	64	7.102	71
7.010.900.101	80	7.010.951.083	49	7.490	70		
7.010.900.102	80	7.010.954.103	163	7.491	70		
49/57/80/114		7.010.954.102	163	7.492	70		
7.010.900.103	80	7.015.95	134	7.550	106		
49/57/80/114		7.015.900.102	136	7.554	162		
7.010.900.110	99	7.015.900.103	136	7.555	153		
7.010.900.125	28	7.015.951.002	136	7.559	106		
7.010.900.127	165	7.015.951.003	136	7.560	106		
7.010.900.128	58/81/115	7.084.943	112	7.564	162		
7.010.900.129	137	7.084.951	112	7.569	106		
7.010.900.135	29/49	7.106	64	7.575	153		
7.010.900.139	50	7.108	42	7.576	107		
701.090.014	50	7.110	96	7.579	107		
7.010.900.162	28	7.105	71	7.580	107		

Limited Liability

Products, design, colors and dimensions are subject to change without prior notice. We reserve the right to make technical improvements on all our products, currently ordered or for future orders. It is the users responsibility to verify all dimensions and technical data. HUMMEL AG will assume no liability regarding information provided to the user by published literature or inside technical staff, its distributors and outside sales personnel. Errors in the catalog can occur and shall not create any liability whatsoever for HUMMEL. All information provided by HUMMEL is without guarantee and must be verified by the user.

Created and printed by

Graphic & Layout: intermedia marketing gmbh, Mozartstraße 2, 79183 Waldkirch, Germany, Tel. +49 (0) 76 81 / 47 78 99-0, Fax +49 (0) 76 81 / 47 78 99-27, kontakt@intermedia-marketing.de  
 Printer: Druckerei Furtwängler GmbH, 79211 Denzlingen, Germany, Tel. +49 (0) 76 66 / 13 31. Printed on recycled paper in March 2009. English 2010

**HUMMEL Brazil**

**HUMMEL Connector Systems Ltda.**  
 Av. Derville Gabriel Pereira, 280  
 Barro Preto Centro Empresarial Tatuí I  
 CEP 18280-623 - Tatuí / SP / Brazil  
 Tel. +55 (15) 33 22-7000  
 Fax +55 (15) 33 22-7026  
 E-Mail vendas@hummel.com.br

[www.hummel.com](http://www.hummel.com)

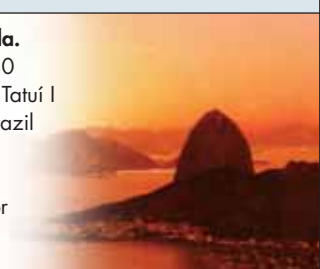

**HUMMEL France**

**HUMMEL s.a.r.l.**  
 4, rue des fleurs  
 68190 Ungersheim / France  
 Tel: +33 (0) 3 89 / 55 37 20  
 Fax: +33 (0) 3 89 / 53 80 27  
 E-Mail: info.fr@hummel.com

[www.hummel.com](http://www.hummel.com)



**HUMMEL China**

**HUMMEL Connector Systems (Shanghai) Co., Ltd.**  
 Central Plaza 1111  
 Huang Pi Bei Road 227  
 200003 Shanghai / P.R. China  
 Tel. +86 / 21 63 75 85-51  
 Fax +86 / 21 63 75 85-53  
 E-Mail info.hcs.cn@hummel.com

[www.hummel.com](http://www.hummel.com)

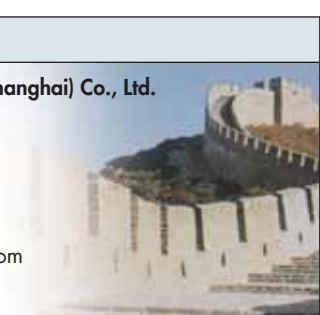

**HUMMEL UK**

**HUMMEL UK Limited**  
 Stedman House  
 95 Church Street, Leigh, Lancashire, WN71 AZ  
 United Kingdom  
 Tel. +44 (0) 19 42 / 60 56 95  
 Fax +44 (0) 19 42 / 26 93 24  
 E-Mail s.kelly@hummel.com

[www.hummel.com](http://www.hummel.com)



**HUMMEL India**

**HUMMEL Connector Systems Pvt. Ltd.**  
 162-A / 9 Kishan Garh, Main Road, Vasant Kunj  
 New Dehli - 110070 / India  
 Tel: +91 11 26 89 4005  
 Fax: +91 11 26 89 4006  
 E-Mail: info.in@hummel.com

[www.hummel.com](http://www.hummel.com)

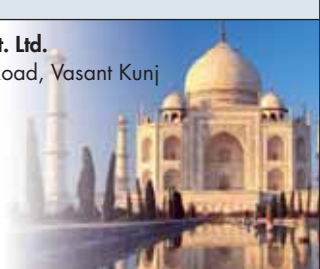

**HUMMEL Italy**

**HUMMEL s.r.l.**  
 Via Valdellatorre 182  
 10091 Alpignano (Torino)  
 Italy  
 Tel. +39 / 011 / 9 68 26 38  
 Fax +39 / 011 / 9 78 55 50  
 E-Mail info.hcs.it@hummel.com

[www.hummel.com](http://www.hummel.com)



**HUMMEL Poland**

**HUMMEL sales Office Poland**  
 Al. 23 Stycznia 26 lok. 30  
 86-300 Grudziadz / Poland  
 Tel: +48 (0) 6 62 38 27 99  
 Fax: +48 (0) 5 66 43 00 11  
 E-Mail: g.piotrowski@hummel.com

[www.hummel.com](http://www.hummel.com)



**HUMMEL Russia**

**OOO HUMMEL**  
 105082, Moskau  
 ul. B. Potschtovaja, d.34, str.8, of.213  
 Tel. +7 / 495 / 7 37 - 44 97  
 Fax +7 / 495 / 7 37 - 44 98  
 E-Mail info@hummel-russia.ru

[www.hummel.com](http://www.hummel.com)

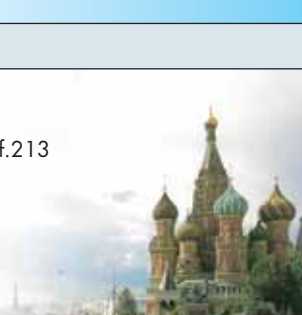

**HUMMEL Scandinavia**

**HUMMEL Connector Systems AB**  
 Första Magasinsgatan 5  
 80310 Gävle / Sweden  
 Tel. +46 (73) 8 00 12 00  
 Fax +46 (26 14) 38 73  
 E-Mail t.larsson@hummel.com

[www.hummel.com](http://www.hummel.com)



**HUMMEL Hungary**

**HUMMEL Connector Systems Kft.**  
 Karösi út 49.  
 2360 Gyál / Hungary  
 Tel. +36 / 29 54 06 33  
 Fax +36 / 29 54 06 35  
 E-Mail info.hcs.hu@hummel.com

[www.hummel.com](http://www.hummel.com)



- Cable Glands
- Circular Connectors
- Cable Protection
- Industrial Enclosures

[info.et@hummel.com](mailto:info.et@hummel.com)



- Sensor Technology
- Controls
- PLC or Control Panel
- Temperature Regulator
- Charging

[info.el@hummel.com](mailto:info.el@hummel.com)



- Systems Solutions
- Cable Assembly
- Custom fabrication of Enclosures
- Front Plates

[info.el@hummel.com](mailto:info.el@hummel.com)



- Metal and Nylon custom parts

[info.mk@hummel.com](mailto:info.mk@hummel.com)



- Valves and Fittings
- DesignTechnik

[info.hs@hummel.com](mailto:info.hs@hummel.com)



## HUMMEL AG

Division ET  
Lise-Meitner-Straße 2  
79211 Denzlingen  
Germany

Tel. +49 (0)76 66 / 9 11 10-0  
Fax +49 (0)76 66 / 9 11 10-20  
E-Mail [info.et@hummel.com](mailto:info.et@hummel.com)

## HUMMEL AG

Lise-Meitner-Straße 2  
79211 Denzlingen  
Germany  
[www.hummel.com](http://www.hummel.com)

