

326/327 Series - Time Delay Relay

SPDT - 3PDT, 10 Amp



The 326 on delay and 327 off delay are “octal” base constructed time delay relays. Both AC and DC versions are available. On delays can have up to three poles. The timing circuit is a fully encapsulated precision RC (resistor – capacitor) network typically used in applications where oscillators are not desired. Fixed time versions are available. Single pole and double pole versions have 8 pin bases. The 3 pole version has 11 pins. All are intended for socket mounting.



GENERAL SPECIFICATIONS (@ 25° C)

Timing:

Functions Available	On-delay, Off-delay
Time Range	Up to 300 seconds
Timing Adjustment	Knob
Timing Repeatability (Constant voltage and temperature)	3%
Reset Time maximum	150mS
Input Pulse Length minimum	50mS

Contacts:

Contact Configuration	SPDT, DPDT, 3PDT
Contact Material	Silver Alloy
Contact Rating	10 Amp / 10 Amp
120 / 240VAC Resistive	10 Amp
28VDC Resistive	1/3Hp
Motor 120VAC	1/2Hp
Motor 240VAC	500mW
Minimum Contact Load	100 milliohms max @ 6VDC, 1A
Contact Resistance, Initial	

Coil:

Coils Available	AC and DC
Nominal Coil Power	2.75VA 2W
Input Voltage Tolerance -AC	85% to 110% of nominal
Input Voltage Tolerance -DC	80% to 110% of nominal
Transient Protection	Yes
Reverse Polarity Protection	Yes
Duty	Continuous

Dielectric Strength:

Across Open Contacts	500Vrms
Between Mutually Insulated Points	1500Vrms
Insulation Resistance	1,000 Mohms min @ 500VDC

Temperature:

Operating	-20 to 70°C (-4 to 158°F)
Storage	-40 to 85°C (-40 to 185°F)

Life Expectancy:

Electrical (full load operations)	100,000
Mechanical (no load operations)	10,000,000

Miscellaneous:

Mounting Position	Any
Mating Socket	8 pin = SK-CIR8-DS 11 pin = SK-CIR11-DS
Enclosure	Clear Polycarbonate
Weight	5.0oz (142 grams)

Ordering Code **326 XAX 48P 001 F 120VAC**

Series

326 - On delay
327 - Off delay

Contact Arrangement

XAX (SPDT) - (1 form C)
XBX (DPDT) - (2 form C)
XCX (3PDT) - (3 form C)

Construction Style

Octal style plug-in - CODE 48P
Non standard wiring - CODE 48P - K

Timing Ranges

0.1 - 1.0 Seconds - CODE 001
0.2 - 2.0 Seconds - CODE 002
1.0 - 10 Seconds - CODE 010
3.0 - 30 Seconds - CODE 033
6.0 - 60 Seconds - CODE 060
18 - 180 Seconds - CODE 180
30 - 300 Seconds - CODE 300

Adjustment Options

Adjustment knob - No CODE
Fixed - Specify fixed time - CODE F 3F - 3 seconds fixed (ie. 3F)
Remote adjustment - CODE R (SPDT, DPDT only) (Call)

Operating Voltage

AC: 24, 120, 240, (Add VAC)
DC: 12, 24, 115-125 (Add VDC)

Timer / Sensor - Time Delay & Sensor Relays

5 - 25 Amp

Outline Dimensions

Dimensions Shown in inches & (millimeters)

8 Pin Octal Base

11 Pin Octal Base

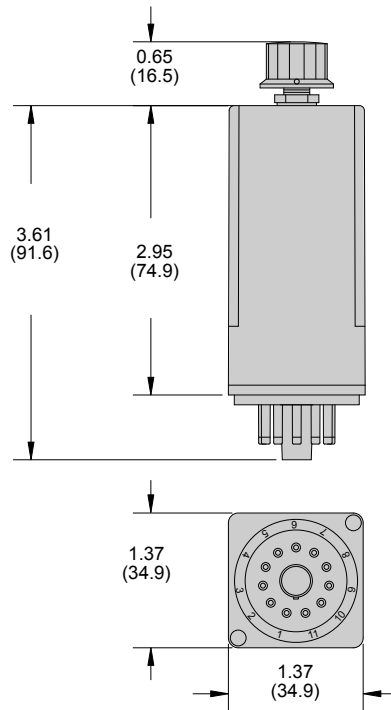
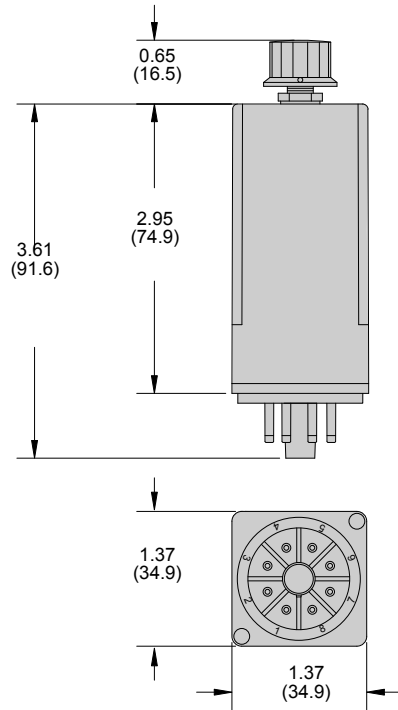

326/327 Wire Diagram

326XAX48P

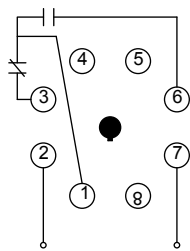

326XBX48P

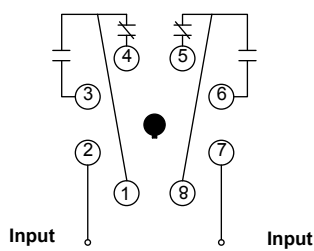

326XCX48P

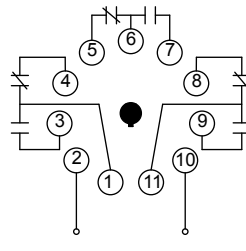

326XAX48RP-R

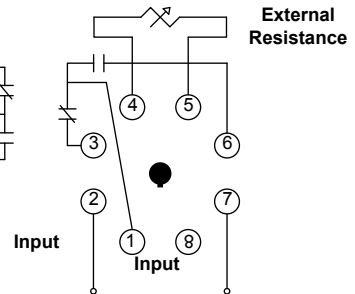

326XBX48RP-R

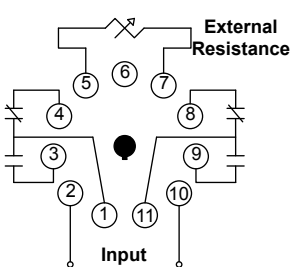

327XAX48RP-R

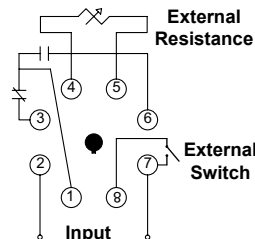

327XBX48RP-K

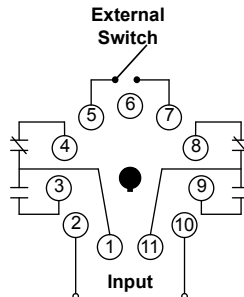

327XBX48P-R

