

Single LED, long type, Ø 3.2 mm

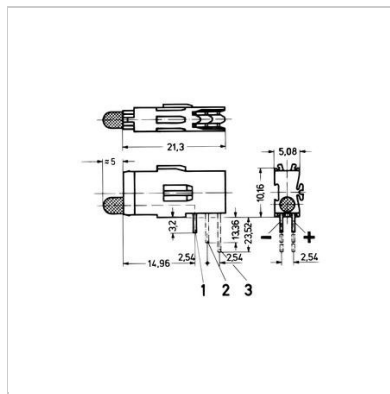

1, 2, 3 = mounting planes

Other Views

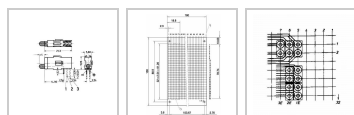

Catalog Number: 69004-059

[Back To Product](#)

- Long type for mounting plane 1

Note:

Required front panel bore Ø 4 mm

Type:

LED

Standard pack quantity (SPQ):

Please take into consideration that deliveries may be carried out in the stated SPQs (SPQ, e.g. 5 pieces, 10 pieces, 50 pieces, etc.). Differing order quantities (e.g. 2 pieces) may be changed to the next possible delivery quantity = Standard Pack Quantity.

LED:

- Single LED, long
- Standard LED

Note:

- Required front panel bore Ø 4 mm
- Connection pin dimensions: 0,5 x 0,5 mm (mounting plane 1)
- Delivery is in standard pack multiples. Pricing is per individual item



Select product specifications before modifying or adding to project list or requesting a quote.

Color-defining

Red

Configuration-defining

Long type for mounting plane 1

[Clear Selection](#)

Quantity

[Add Item to Project List +](#)

Documents



Main Catalog - Front panel component systems

Technical Data

Qty	1 piece (SPQ 10)	Operating temperatures [°C]	-40 ... +85 °C
Delivery is exclusively made in Standard Pack Quantity (SPQ)	10	Absolute maximum data, Ta = 25 °C	standard LED
Color	red	Reverse voltage [V]	5
Configuration	Mounting plane 1	On-state current [mA]	25
		Power dissipation [mW]	100
		Forward current [mA] (t < 10 µs)	100
		Forward Voltage [V] type (10 mA/2 mA)	2.1
		Forward voltage [V] max. (10 mA/2mA)	3
		Luminous intensity [mcd] at 10 mA	1.8

Luminous intensity [mcd] at 20 mA	3,6
Wavelength [nm] (10 mA/2 mA)	635
Thermal resistance [°C/W]	400
Angle of reflected beam	± 50°
Storage temperature [°C]	-55 ... +100 °C
Solder temperature [°C]	260 °C/max. 5 sec (processing advice for wave soldering: protect plastic body against solder wave)
Insulating body	PBT (Crastin)
Flammability of insulation body	UL 94 V-0

EXPLORE

[About Us](#)
[Services & Capabilities](#)
[News & Events](#)
[Newsletter Subscriptions](#)
[Strategic Partnerships](#)
[Investor Relations](#)

CONTACT

[Customer Service](#)
[Find a Sales Office or Distributor](#)
[Global Locations](#)
[Product Compliance & Certifications](#)
[Partner Login](#)

DOWNLOAD

[Download Center](#)
[Reference Projects](#)
[Videos](#)
[Product Configurators](#)
[Warranties and Terms of Sale & Procurement](#)

© 2018/2018 Pentair. All rights reserved | [Privacy Policy](#) | [Terms of Use](#) | [Cookie Policy](#) | [Imprint](#) | [Site Map](#)

Connect With Us

