

Schroff

EPCASE

Content

Wall mounted cases - *epcase*

Cabinets 1

Wall mounted cases 2

Accessories for cabinets and wall mounted cases . 3

Climate control . 4

Electronics cases 5

Subracks/ 19" chassis 6

Front panels, plug-in units . . . 7

Systems 8

Power supply units 9

Backplanes . . . 10

Connectors, front panel component system 11

Appendix 12



01505008



01506002

Hinged side panels for easy access



01505003

Optimum space utilisation due to an additional vertical 19" plane; fans retrofitable

Standards

- Type of protection IP 20 IEC 60529

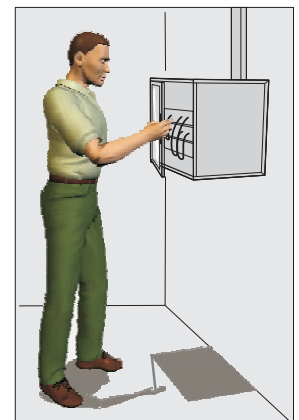
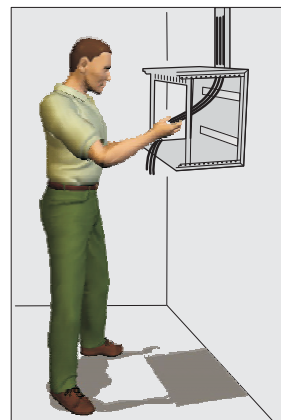
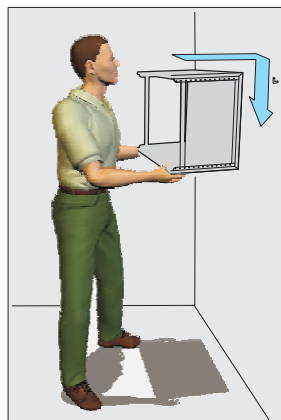

01504051

Simple design and assembly: mounting, wiring, cladding

Wall mounted cases - *epcase*

Low-cost wall mounted case

- Hinged side panels for easy access
- Completely pre-assembled
- Optimum space utilisation through depth-adjustable 19" slide mounts and an additional vertical 19" plane
- Type of protection IP 20



01506001

epcase 19"

- 19" assembly from 9 ... 20 U



01505006

epcase 10"

- 10" assembly from 4 ... 12 U

epcase 19"

- 19" wall mounted case 2.26
- Fan 2.27
- Protective grille .. 2.27
- Air filter 2.28
- Lever handle 2.28
- 19" equipment shelf 2.29
- Modem shelf 2.30
- Vertical 19" plane 2.30
- Cable eye 2.31
- Cable support rail 2.31
- Short slide rail... 2.31

epcase 10"

- 10" wall mounted case 2.32
- Air filter 2.33
- Equipment support 2.33
- 10" front panel... 2.34
- 10" distribution field 2.34
- 10" socket strip 1 U, SCHUKO 2.35

ServicePLUS... 2.46



30407004

ServicePLUS from page 2.46

- e.g. special colours, special sizes
- e.g. air conditioning
- e.g. fittings, conversions, cut-outs
- e.g. custom solutions

www.schroff.biz/ServicePLUS

Wall mounted cases - *epcase*

19" wall mounted case



01506002

- Multi functional 19" wall case with hinged side panels
- Cable entry possible from above or below; the cable entry opening can be sealed with two brush strips each, resp. can be used to assemble fan
- Cable support rail is included and is adjustable in 25 mm increments
- 19" panel/slide mounts are depth-adjustable in 25 mm increments
- Type of protection IP 20

Delivery comprises (assembled)

Item	Qty	Description
1	1	Basic case, C form, St, 2 mm, RAL 7021
2	1	Glazed door with key/lock (key no. 2233), door handle cut-out S2100, frame, St, 1.5 mm, RAL 7035, Sekurit glass 4 mm
3	2	Side panel, St, 1.5 mm, RAL 7035
4	1	Cable support rail, St, RAL 7035
5	2	19" slide mounts, St, 2 mm, finish AlZn
6	2	Brush strip (to cover cable entry opening)
7	1	Assembly kit for wall mounting

Order Information

Height U	Height H mm	Width W mm	Depth D mm	Depth E mm	Weight kg	Load-carrying capacity kg	Part no.
9	487	600	300	18	18	60	10236-151
9	487	600	400	18	20	35	10236-152
12	612	600	400	18	24	35	10236-156
12	612	600	500	85	25	30	10236-157
16	812	600	400	18	28	35	10236-160
16	812	600	500	85	30	30	10236-161
16	812	600	600	85	32	25	10236-162
20	962	600	500	85	34	30	10236-165
20	962	600	600	85	38	25	10236-166
GND/earthing, PU 1 kit							21236-097
Brush strip, 1 piece							21236-094
Feet, plastic, black, PU 4 pieces							21236-089
Cable shell for cable bundle 30 ... 34 mm, PU 10 pieces							20114-728
Cable tie 92 mm x 2.5 mm, PU 25 pieces							20118-351
19" assembly kit (screw, washer, nut) (32 x M6 screws x 16, 32 x plastic washers, 32 x cage nuts)							21190-435

Note

- Lever handle for single point locking with DIN profile half cylinder is retrofittable, see page 2.28

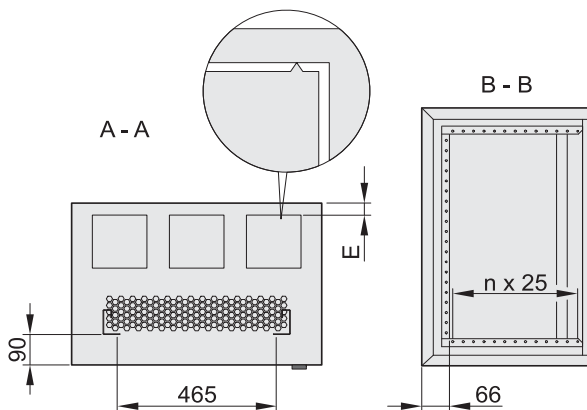
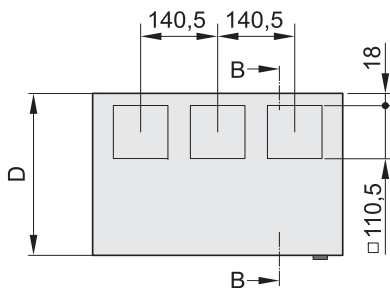
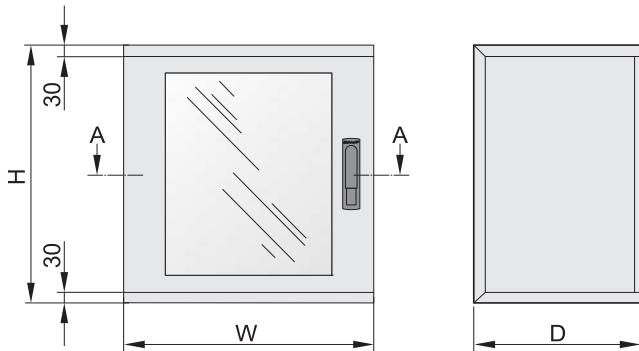

eca44458



ServicePLUS see page 2.46

Wall mounted cases - *epcase*

Fan with covering grille, 230 V_{AC}

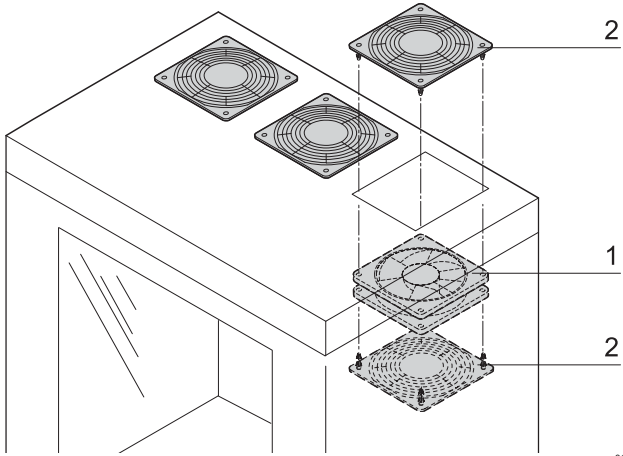

01503057

- For assembly in cable ducting openings (top/bottom)
- Assembly of fan by clipping in protective grilles
- Connect up to 3 fans via separate connecting cable

Delivery comprises

Item	Qty	Description
1	1	230 V _{AC} fan, dimensions 38 x 119 x 119 mm
2	2	Protective grille, plastic, black

Order Information

Description	Part no.
Fan with covering grille, 230 V _{AC}	21236-092
Connecting cable for 1 ... 3 fans IEC-320 male connector, 1 piece	21236-099
Thermostat with mains/line connector, 230 V _{AC} , SCHUKO/UTE connector, IEC-320 female connector, 1 piece	20118-750

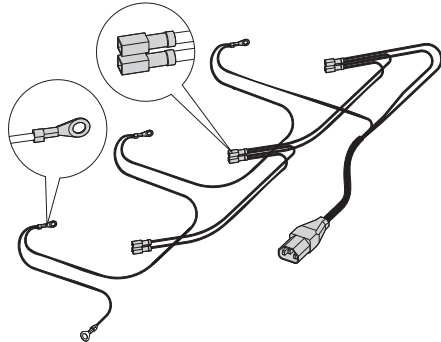

Connecting cable and earthing for 1 ... 3 fans

01505057

Technical data

Frequency	50 Hz	60 Hz
Voltage	230 V _{AC}	230 V _{AC}
Air volume, unrestricted	162 m ³ /h	192 m ³ /h
Noise pressure level	37 dB(A)	41 dB(A)
Max. static pressure	73 Pa	88 Pa
Max. ambient temperature	+70 °C	+70 °C
Power consumption	15 W	14 W

Note

- Please order connecting cable separately

Protective grille

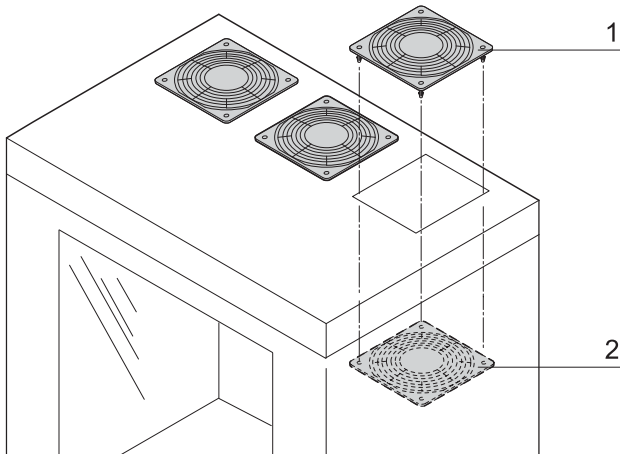

01505058

- For passive cooling
- To cover the opening

Delivery comprises

Item	Qty	Description
1	1	Protective grille with pins, plastic, black
2	2	Protective grille with cut-outs, plastic, black

Order Information

Description	Part no.
Protective grille	21236-127

Wall mounted cases - *epcase*

Air filter for 19" wall mounted case

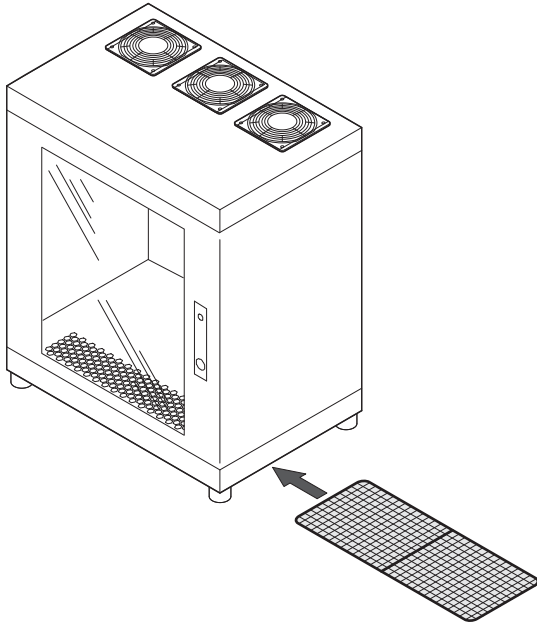

01505059

- Filtering of the inlet air at the case bottom
- Assembly beneath the case, easy filter replacement
- Filter class G3

Delivery comprises

Item	Qty	Description
1	2	Support bracket, St, 1 mm, RAL 7021
2	3	Filter mat with round steel frame, filter class G3
3	1	Assembly kit

Order Information

Description	Part no.
Air filter for case depth 300/400 mm	21236-103
Air filter for case depth 500/600 mm	21236-104
Replacement filter mat for case depth 300/400 mm, PU 3 pieces	21236-125
Replacement filter mat for case depth 500/600 mm, PU 3 pieces	21236-123

Lever handle for single point locking



01005016

- For installation instead of key lock insert
- To open press push-button
- DIN profile half cylinder retrofittable

Delivery comprises

Item	Qty	Description
1	1	Lever handle for single point locking
2	1	Assembly kit

Order Information

Description	Part no.
Lever handle for single point locking	23130-067
DIN profile half cylinder, common locking for lever handle (1 key fits all locks) incl. 2 keys	25127-995

Note

- Other locks such as ASSA, KABA or RONIS available on request

Wall mounted cases - *epcase*

19" equipment shelf, 1 U

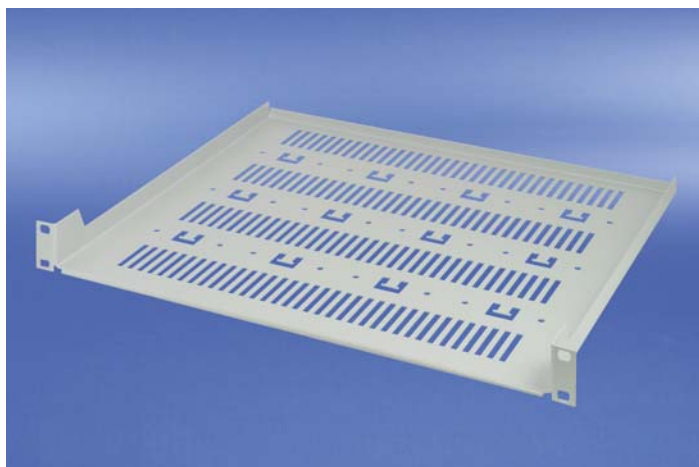

00508006

- Static load-carrying capacity 5 kg
- Mounting height 1 U

Delivery comprises

Item	Qty	Description
1	1	Equipment shelf, St, 1.5 mm

Order Information

Width mm	Depth mm	RAL 7035 Part no.
447	390	20118-783

19" assembly kit (screw, washer, nut) (4 x M6 screws x 16, 4 x plastic washers, 4 x cage nuts)	21190-095
---	-----------

19" equipment shelf, 2 U

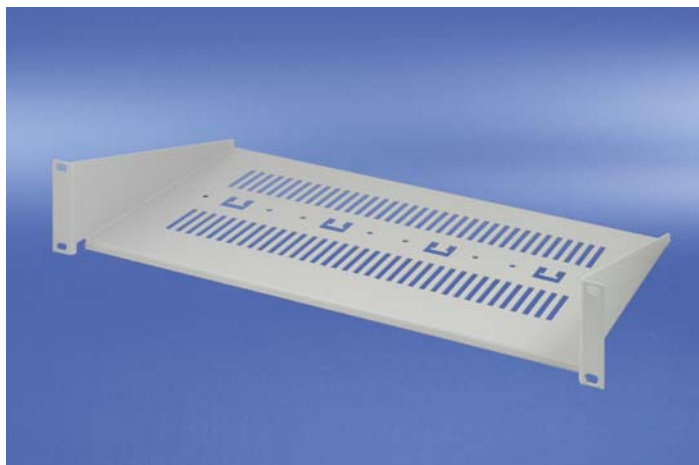

00508002

- Static load-carrying capacity 10 kg
- Mounting height 2 U

Delivery comprises

Item	Qty	Description
1	1	Equipment shelf, St, 1.5 mm

Order Information

Width mm	Depth mm	RAL 7035 Part no.
447	238	20118-785

19" assembly kit (screw, washer, nut) (4 x M6 screws x 16, 4 x plastic washers, 4 x cage nuts)	21190-095
---	-----------

19" equipment shelf, depth-adjustable, 2 U

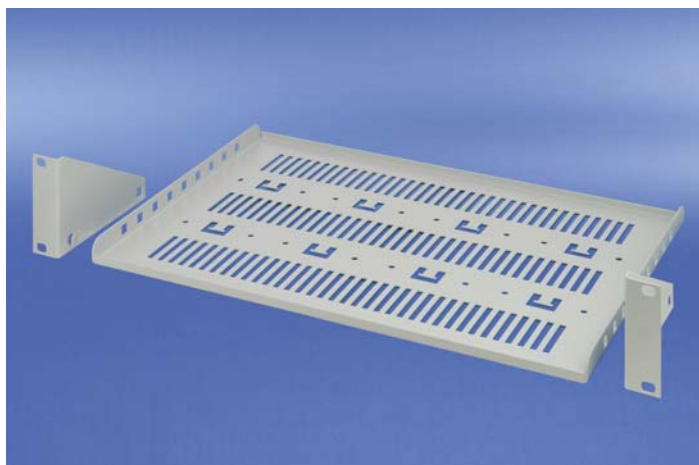

00508009

- Static load-carrying capacity 15 kg
- Mounting height 2 U
- Depth-adjustable in 25 mm increments (front protrusion min. 26 mm)

Delivery comprises (kit)

Item	Qty	Description
1	1	Equipment shelf, St, 1.5 mm
2	2	Mounting bracket with assembly kit, St, 1.5 mm

Order Information

Width mm	Depth mm	RAL 7035 Part no.
430	250	
430	300	20118-790

19" assembly kit (screw, washer, nut) (4 x M6 screws x 16, 4 x plastic washers, 4 x cage nuts)	21190-095
---	-----------

Wall mounted cases - *epcase*

Modem shelf

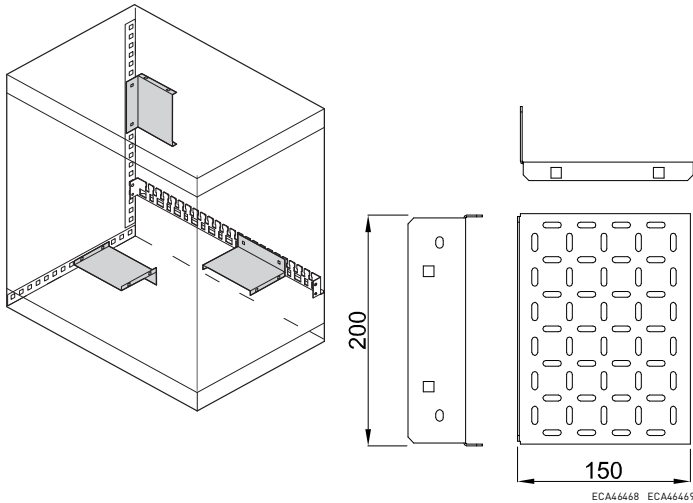

- For fixing modems and other devices
- Assembly onto the cable support rail or direct onto the case
- Static load-carrying capacity 3 kg

Delivery comprises

Item	Qty	Description
1	1	Modem shelf, St, 1.5 mm, RAL 7035
2	1	Assembly kit

Order Information

Width mm	Depth mm	Part no.
200	150	21236-122

Vertical 19" plane

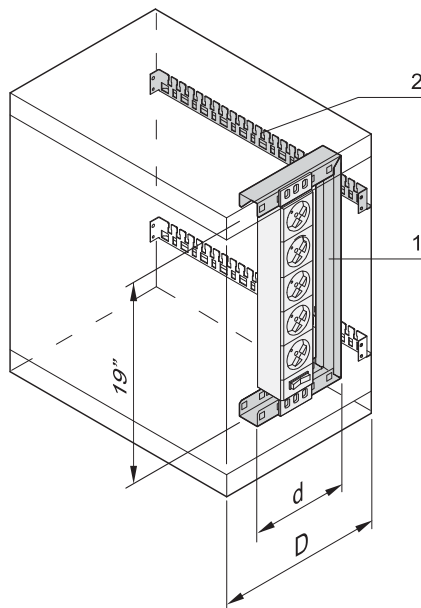

- For lateral, vertical assembly of 19" components
- Useable for case heights from 12 U

Delivery comprises (kit)

Item	Qty	Description
1	1	Vertical 19" plane, St, 2 mm, RAL 7035
2	1	Cable support rail, St, RAL 7035
3	1	Assembly kit

Order Information

Height U	d mm	For case depth D mm	Part no.
3	167	300 ... 600	21236-120
6	300	400 ... 600	21236-121

Assembly example with 19" socket strip

01505062

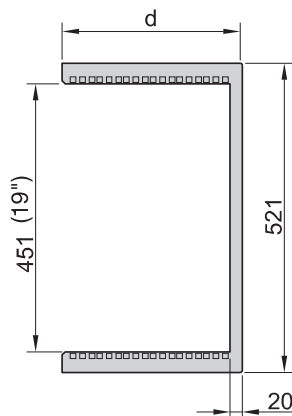

ECA46477

Wall mounted cases - *epcase*

Cable eye

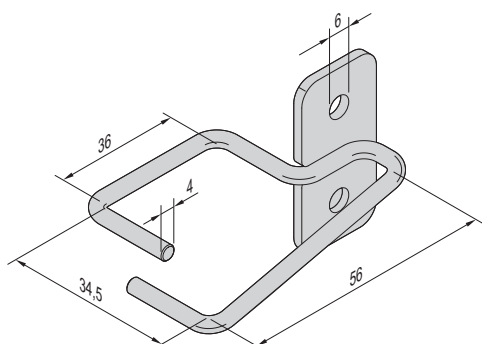

01505051

- For cable fixing/ducting laterally on the panel slide mounts

Delivery comprises

Item	Qty	Description
1	4	Cable eye, St, 4 mm, zinc-plated
2	1	Assembly kit

Order Information

Description	Part no.
Cable eye	21236-102

Cable support rail

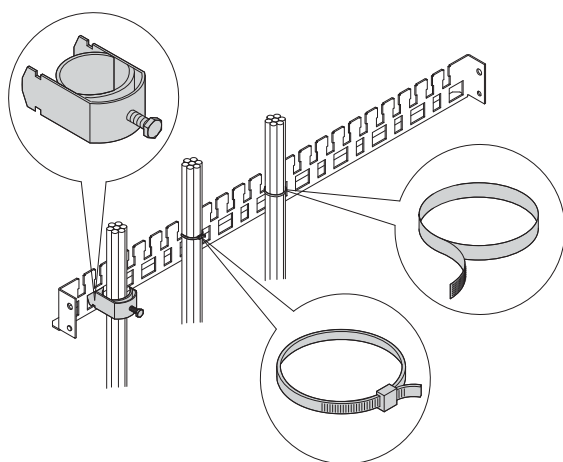

01505052

- For strain relief or cable ducting on rear

- Height-adjustable in 25 mm increments

Delivery comprises

Item	Qty	Description
1	1	Cable support rail, St, 1.5 mm, RAL 7035
2	1	Assembly kit

Order Information

Description	Part no.
Cable support rail	21236-090
Cable shell for cable bundle 30 ... 34 mm, PU 10 pieces	20114-728
Cable tie 92 mm x 2.5 mm, PU 25 pieces	20118-351
Velcro strip Polyethylen/Polyamide, black, length 300 mm, PU 10 pieces	20118-624

Note

- A cable support rail is already supplied with the 19" wall mounted case

Short slide rail

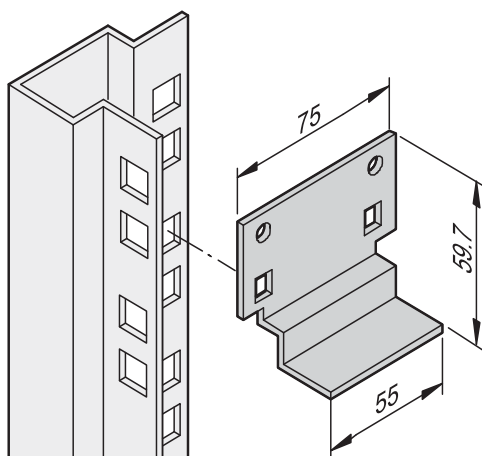

sc96xxxx

- Support for heavy 19" chassis
- To attach on 19" slide mounts
- Static load-carrying capacity max. 15 kg per pair

Delivery comprises

Item	Qty	Description
1	2 / 10	Short slide rail, St, 1.5 mm, finish AlZn
2	1	Assembly kit

Order Information

Description	Qty/PU	Part no.
Short slide rail	2	23130-094
Short slide rail	10	23130-095

Wall mounted cases - *epcase*

10" wall mounted case



01505007

- Multi-functional 10" wall case with hinged side panels
- Cable entry possible from above or below; the cable entry opening can be sealed with a brush strip
- 10" slide mounts are depth-adjustable in 25 mm increments

Delivery comprises (assembled)

Item	Qty	Description
1	1	Basic case, C-form, St, 2 mm, RAL 7021
2	1	Glazed door with key lock (key no. 2233), frame, St, 1.5 mm, RAL 7035, Sekurit glass, 4 mm
3	2	Side panel, St, 1,5 mm, RAL 7035
4	2	10" panel/slide mounts, St, 1.5 mm, finish AlZn
5	2	Brush strips
6	1	Assembly kit for wall mounting

Order Information

Height U	Height H mm	Width W mm	Depth D mm	Weight kg	Part no.
4	262	345	280	5	10238-151
8	462	345	280	10	10238-152
12	612	345	280	23	10238-153
GND/earthing, PU 1 kit					21236-097
Cable tie 92 mm x 2.5 mm, PU 25 pieces					20118-351
19" assembly kit (screw, washer, nut) (32 x M6 screws x 16, 32 x plastic washers, 32 x cage nuts)					21190-435
Feet, plastic, black, PU 4 pieces					21236-089

Note

- Lever handle and DIN profile half cylinder cannot be retrofitted

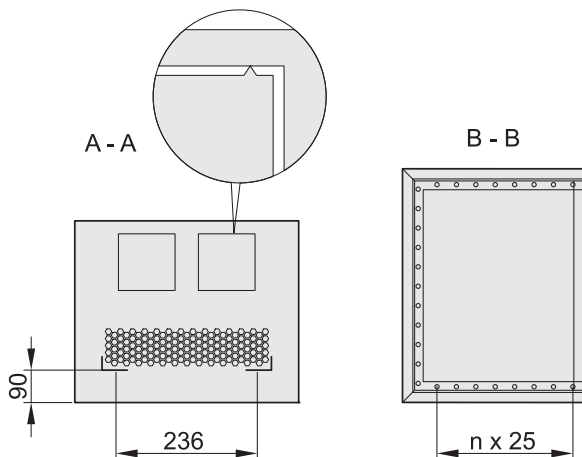
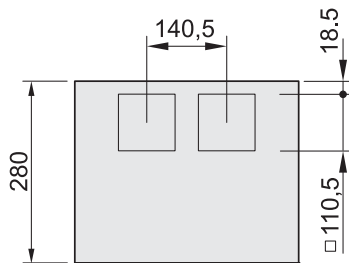
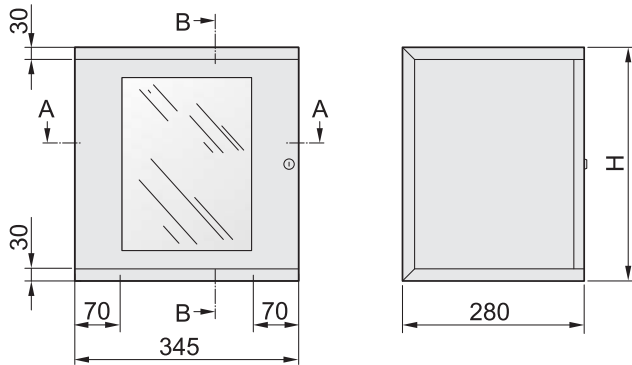

eca46478



ServicePLUS see page 2.46

Wall mounted cases - *epcase*

Air filter for 10" wall mounted case

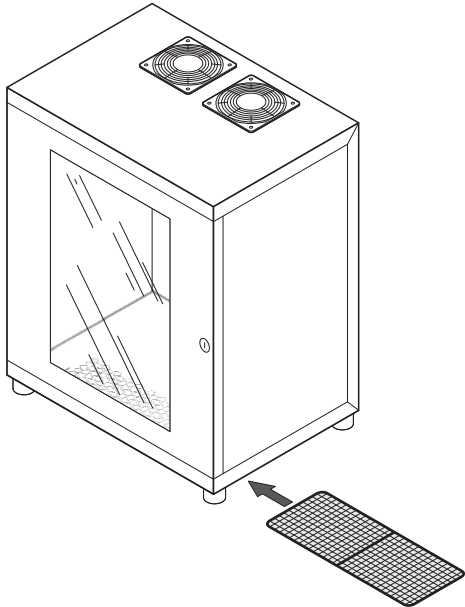

01506050

- Filtering of the inlet air at the case bottom
- Assembly beneath the case, easy filter replacement
- Filter class G3

Delivery comprises

Item	Qty	Description
1	2	Support bracket, St, 1 mm, RAL 7021
2	3	Filter mat with round steel frame, filter class G3
3	1	Assembly kit

Order Information

Description	Part no.
Air filter for 10" wall mounted case	21236-095
Replacement filter mat for 10" wall mounted case PU 3 pieces	21236-126

Equipment shelf for 10" wall mounted case

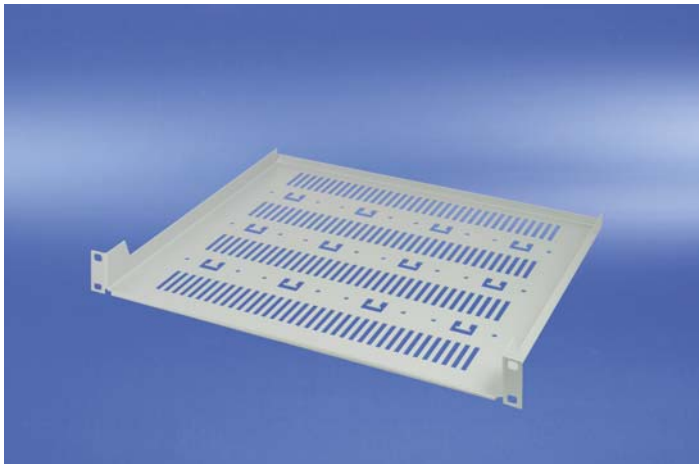

00508006

- Static load-carrying capacity 5 kg
- Mounting height 1 U
- Width 10" (254 mm)

Delivery comprises

Item	Qty	Description
1	1	Equipment shelf, St, 1.5 mm, RAL 7035
2	1	Assembly kit

Order Information

Width mm	Depth mm	Part no.
220	150	20118-716

Wall mounted cases - *epcase*

10" distribution field



01504002

- Distribution field with 8 x RJ 45 ports, category 5
- Height 1 U
- Width 10" (254 mm)

Delivery comprises

Item	Qty	Description
1	1	Distribution field, St, 1.5 mm, RAL 7035
2	8	RJ 45 Port

Order Information

Description	Part no.
10" distribution field with 8 x RJ 45 ports	60118-378
Assembly kit PU = 8 x screw, washer, nut	21100-435

10" front panels

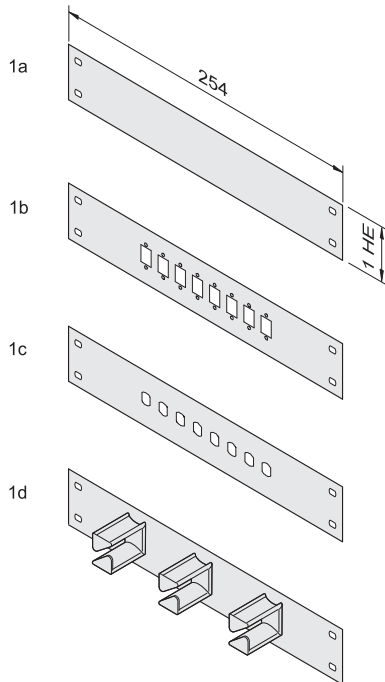

01503053

- Height 1 U
- Width 10" (254 mm)

Delivery comprises

Item	Qty	Description
1	1	Front panel, St, 1.5 mm, RAL 7035

Order Information

Item	Description	Qty/PU	Part no.
1a	10" blank front panel, St, 1.5 mm, RAL 7035	1	20118-717
1b	10" front panel, 8 ports SC, St, 1.5 mm, RAL 7035	1	20118-713
1c	10" front panel, 8 ports ST, St, 1.5 mm, RAL 7035	1	20118-714
1d	10" front panel with 3 plastic cable eyes, St, 1.5 mm, RAL 7035	1	20118-715
Assembly kit PU = 8 x screw, washer, nut			21100-435

Wall mounted cases - *epcase*

10" socket strip, 1 U



00704001

- Socket strip with four socket inserts
- Bracket for mounting on 10" upright is included

Delivery comprises

Item	Qty	Description
1	1	Socket strip 10", 1 U, 4 socket inserts, 2 m connecting cable with SCHUKO/UTE connector
2	2	Mounting bracket for 10" assembly

Order Information

Description	Part no.
10" socket strip, 4 SCHUKO socket inserts	60110-201
Socket strip 10", 4 UTE socket inserts	60110-220
Assembly kit PU = 8 × screw, washer, nut	21100-435

Wall-mounted cases ServicePLUS



modification

Custom drillings, cut-outs and special colours for off-the-shelf products

Small changes. Large impact.

- Custom drillings, special colours, cut-outs for off-the-shelf products from
 - 10 pieces with epcase
 - 25 pieces with CONCEPTLINE, INLINE, QLINE, A48, wall mounted LAN enclosures
- Further information: www.schroff.co.uk/modification



solution

Integration and custom developments

Simple. Fast. From one source.

- Special sizes, custom solutions, printing from:
 - 10 pieces with epcase
 - 25 pieces with CONCEPTLINE, INLINE, wall mounted LAN enclosures
 - 500 pieces with QLINE, A48
- Integration: components, internal mounting, wiring
- Further information: www.schroff.co.uk/solution

ServicePLUS solution - project examples



40508001

Plastic case A48 or QLINE

- Plain or glazed doors
- Individual printing, cut-outs, with PG screw fitting or with complete assembly



40708001

Steel case INLINE

- Terminal case or installation case with support rails or mounting plates with customised depth bolts
- Cut-outs and drillings marked with specified printing; paint-free contact area for installed components

Wall-mounted cases ServicePLUS

ServicePLUS solution - project examples

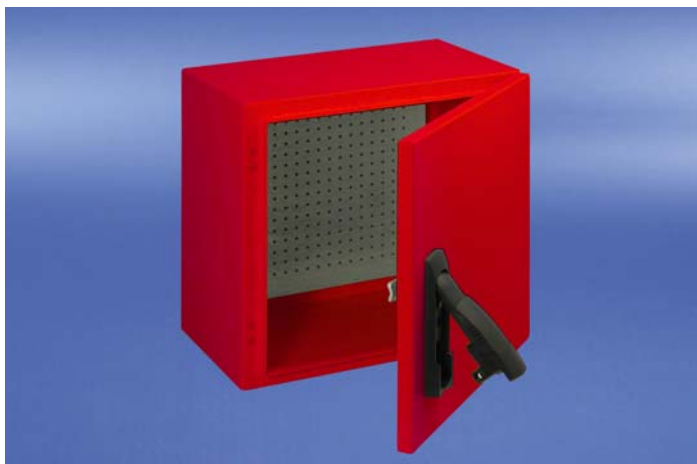

41108003

CONCEPTLINE in special colour (RAL 3027)

- Steel case with a high type of protection: IP 66
- Mounting plate with hole grid to fix assemblies
- Lever handle with optional DIN cylinder



41108002

CONCEPTLINE control module

- Vehicle data processor in CONCEPTLINE case (IP 66)
- Internal mounting on basis of europacPRO subrack with individually machined front panels



41108001

CONCEPTLINE communication module

- CONCEPTLINE case with heat exchanger (IP 55)
- Internal mounting on basis of europacPRO subrack and backplane for the digital GSM-R communication network

Appendix – Order notes

Packaging units

A packaging unit (PU) - e.g. carton, bag - contains the stated quantity. If you order the quantity 1, you will automatically receive the quantity defined as PU.

Example: EMC textile gasket
See page 5.22
Part number 21101-853

Quantity (per part number): 10 pieces

Order quantity: Delivery quantity:

1	10 pieces
2	20 pieces
3	30 pieces

Price list

Our price list is available by e-mail from your customer consultant. Please find all contact details at www.schroff.biz/contact.

Always up-to-date

Please visit our website www.schroff.biz where we continuously inform about news and technical changes.

Quick links

Catalogue request: www.schroff.biz/catalogues

Product configurators: www.schroff.biz/conf

Contact details: www.schroff.biz/contact

Product search: www.schroff.biz/oneclick

Front Panel Express: www.frontpanelexpress.eu

VARISTAR: www.varistar.co.uk

Railway technology: www.schroff.co.uk/railway

IT Infrastructure: www.schroff.co.uk/datacom

Standard pack quantity (SPQ)

Please take into consideration that deliveries may be carried out in the stated SPQs (SPQ, e.g. 5 pieces, 10 pieces, 50 pieces, etc.). Differing order quantities (e.g. 2 pieces) may be changed to the next possible delivery quantity = Standard Pack Quantity (in this case 10 pieces).

Example: Front horizontal rail
See page 5.31
Part number 34560-228

Quantity (per part number): 1 piece
Standard pack quantity (SPQ): 10 pieces

Order quantity: Delivery quantity:

≤ 10	10 pieces
> 10 ≤ 20	20 pieces
> 20 ≤ 30	30 pieces

Delivery times

Part numbers in bold face type are ready for despatch within 2 working days; part numbers in normal type are ready for despatch within 10 working days.

Business relations

Schroff is exclusively operating in Business to Business (B2B). Private individuals can buy Schroff products via our sales representatives (see www.schroff.biz/contact).

Responsible for contents and print

Schroff GmbH, Marketing Communication,
D-75334 Straubenhardt, Germany

The data in this catalogue have been thoroughly edited and checked - in assistance with an accredited Quality Management System in accordance with EN ISO 9001:2008.

Faults and spelling mistakes, but mainly changes due to improvements and further developments of our products are subject to change. There is no possibility to claim indemnity/compensation.

Cabinets	Overview.....	1.0	LHX 20/40 Air/water heat exchangers.....	1.224	1
	Varistar Cabinet platform.....	1.2	LHX 3 Air/water heat exchangers.....	1.236	
	Varistar Electronics.....	1.10	Novastar.....	1.240	
	Varistar EMC.....	1.54	Eurorack.....	1.270	
	Varistar Seismic.....	1.84	Outdoor.....	1.316	
	Varistar MIL.....	1.120	Etsirack.....	1.346	
	Varistar Data/network systems.....	1.124	19" lab racks.....	1.354	
	Varistar Containment.....	1.202	PROLINE.....	1.362	
Wall mounted case	Overview.....	2.0			2
	Epcase.....	2.36			
	LAN wall-mounted distributors.....	2.46			
Cabinet and wall-mounted case accessories	Overview.....	3.0	Monitors, keyboards, monitoring.....	3.44	3
	Mechanics.....	3.2	Socket strips.....	3.50	
	Telescopic slides.....	3.24	Power control socket strips.....	3.72	
	Electrical.....	3.29			
Climate control	Overview.....	4.0	Accessories.....	4.58	4
	Cooling concepts/service.....	4.2			
	19" fan trays.....	4.4			
	Air filtered fans.....	4.20			
Desktop enclosures	Overview.....	5.0	Comptec.....	5.100	5
	RatiopacPRO.....	5.6	Accessories.....	5.108	
	PropacPRO.....	5.44	Interscale.....	5.200	
	CompacPRO.....	5.76	Minipac.....	5.230	
Subracks/ 19" chassis	Overview.....	6.0	EuropacPRO industrial applications.....	6.86	6
	EuropacPRO.....	6.2	EuropacPRO Rugged.....	6.92	
	EuropacPRO for railroad applications.....	6.70	MultipacPRO.....	6.112	
			Inpac.....	6.128	
Front panels, Plug-in-units, Frame type plug-in-units	Overview.....	7.0	PCB accessories.....	7.102	7
	Front panels.....	7.2			
	Plug-in units.....	7.16			
	Frame type plug-in units.....	7.64			
Systems	Overview.....	8.0	AdvancedMC modules.....	8.56	8
	AdvancedTCA.....	8.2	CompactPCI, Serial, PlusIO, PSB.....	8.68	
	AdvancedMC carriers.....	8.26	VME, VME64x, VXS, VPX.....	8.88	
	MicroTCA.....	8.36	Accessories.....	8.106	
Power supply systems	Overview.....	9.0	19" accessories.....	9.18	9
	19" AC/DC switched-mode PSUs.....	9.2	PSUs for MicroTCA.....	9.20	
	19" AC/DC linear regulators.....	9.12	PSUs for VMEbus.....	9.22	
	19" AC/DC convertors.....	9.15	PSUs for CompactPCI, VME64x.....	9.24	
Backplanes	Overview.....	10.0	VME64x, VMEbus.....	10.15	10
	CompactPCI, Serial, PlusIO.....	10.4	Power.....	10.18	
	PXI.....	10.11	Universal.....	10.19	
	VXS.....	10.14	Test adaptors.....	10.20	
Connectors, Front panel component systems	Overview.....	11.0			11
	Connectors.....	11.2			
	Front panel component system.....	11.12			
Appendix	Standards abbreviations.....	12.0			12
	Notes on ordering.....	12.10			
	Order number index.....	12.11			
	Product index.....	12.62			