

Coding peg

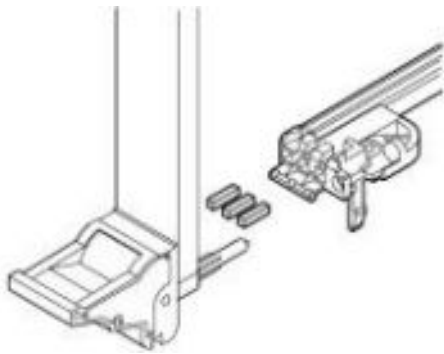

Product illustrations are exemplary illustrations and can deviate from supplied products.

Part no.:
20817-
501

Features:

- Coding pegs provide coding for plug-in units, preventing their being inserted into the wrong slots. The pegs are inserted into the chambers of the codeable board guides and IEL and IET inserter/extractor handles (4 positions possible). Total 64 coding possibilities per board guide; in the case of keying/coding the top and bottom guide rail there are 4096 keying/coding possibilities.
- Mounts in the bottom and top horizontal rail



Technical information:

Description	Material	Color	Qty/PU
Coding peg	PC, UL 94 V-0	grey, RAL 7035	100 piece

Note:

- Guide rail for keying/coding see europacPRO accessories