

PART NO.	DIM. "A"
WIT-18R1A-4-01	1/4"(6.4)

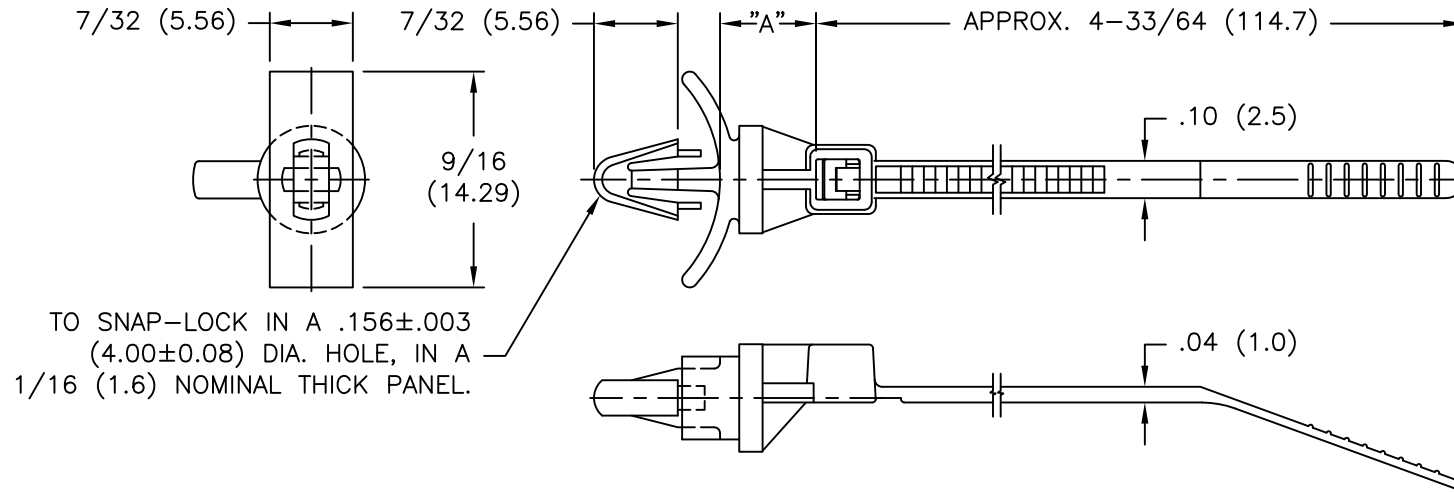

NOTES:

1. MATERIAL: NYLON 6/6 (RMS-01), NATURAL.  
UV STABILIZED NYLON (RMS-46), BLACK.  
BY SPECIAL ORDER.  
FLAME RETARDANT NYLON (RMS-75), NATURAL.  
BY SPECIAL ORDER.
2. MIN. LOOP TENSILE: 18 LBS (80 NEWTONS).
3. MAX. BUNDLE DIAMETER: 3/4 (19.1).

TITLE: SELF MOUNT WRAP-IT-TIES			DWG IN IN (MM)		FINAL				
D	SEE CO 200557 FOR CHANGES	SK 07.19.10	FILE #	WIT-18R1A	DWN:	S.M.	APP:	PART #	PRINT TYPE
C	SEE CO 200134 FOR CHANGES	SK 02.28.08	MAT'L:	SEE NOTES	DT:	03/15/01	DT:		
B	COMPLETELY RE-DRAWN; NEW NOTES AND CHANGED FILE NO.	SM 03.15.01	RE:	RICHCO, INC.	RICHCO INC. PO BOX 804238, CHICAGO, 60680 (773) 539-4060				
A	DIM(4.75±.08) WAS (4.75±.8)	J.L. 6/10/99							
REV	DESCRIPTION	ENGR DATE							

TOLERANCES  
UNLESS NOTED  
.XX=±.010  
.XXX=±.005  
FRAC=±1/64  
ANG=±1°