

PART NO.	"A" REF.	"B"±.025 (±0.63)	INTERCHANGE WITH S.A.E.
RSFS-250	2.5 (63.5)	1.5 (38.1)	1200F
RSFS-300	3.0 (76.2)	2.0 (50.8)	
RSFS-350	3.5 (88.9)	2.5 (63.5)	
RSFS-400	4.0 (101.6)	3.0 (76.2)	
RSFS-450	4.5 (114.3)	3.0 (76.2)	1400F
RSFS-451	4.5 (114.3)	3.5 (88.9)	
RSFS-500	5.0 (127.0)	4.0 (101.6)	
RSFS-550	5.5 (139.7)	4.5 (114.3)	
RSFS-600	6.0 (152.4)	5.0 (127.0)	1600F
RSFS-650	6.5 (164.1)	5.0 (127.0)	1650F
RSFS-651	6.5 (164.1)	5.5 (139.7)	
RSFS-700	7.0 (177.8)	6.0 (152.4)	
RSFS-750	7.5 (190.5)	6.5 (165.1)	
RSFS-800	8.0 (203.2)	7.0 (177.8)	1800F

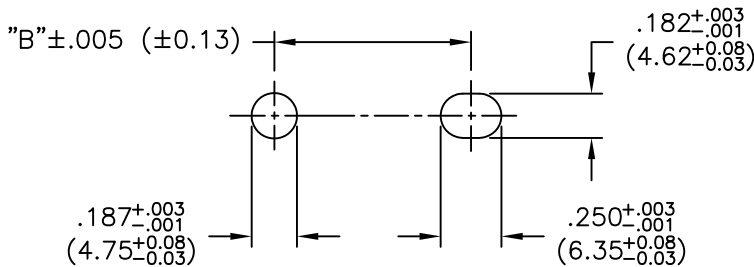
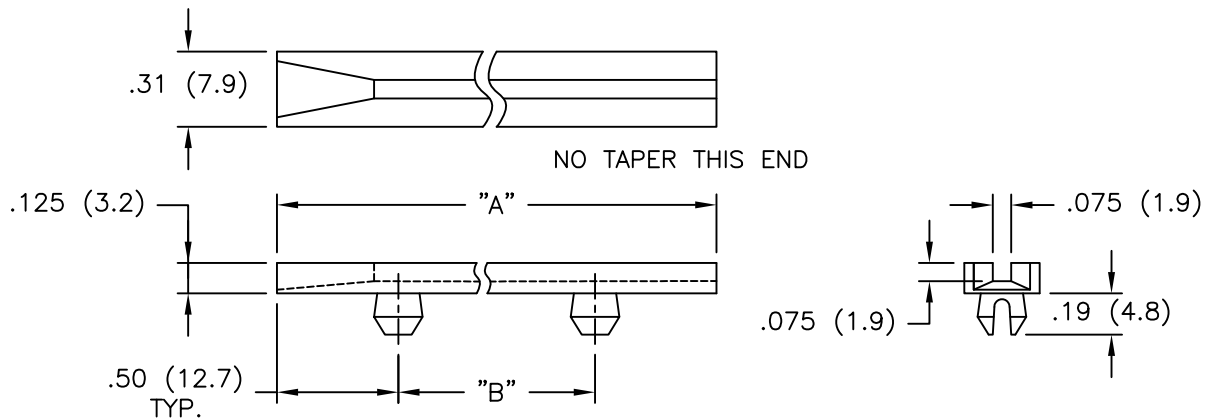

RECOMMENDED MOUNTING HOLES
 PANEL THICKNESS: .047-.090 (1.2-2.3)

NOTES:

1. MATERIAL: NYLON 6/6 (RMS-48).
2. COLOR: NATURAL.

I	CHANGE "B" DIM OF -650 SEE CO 200732	DZ 11.07.11
H	SEE ECN #831 FOR CHANGES	SM 08.09.04
G	SEE ECN #547 FOR CHANGES	SM 12.20.02
F	SEE ECN #526 FOR CHANGES	SM 11.21.02
E	COMPLETELY REDRAWN AND CHANGED FILE NO.	SM 02.12.02
D	MOUNTING HOLE AND SLOT UPDATED	J.L. 04.19.00
C	MOUNTING HOLE WAS .187 SLOT WAS .182X.250	FL 04.06.99
B	DIM. "A" WAS REF.	RS 11.25.92
A	METRIC DIMS CORRECTED	RS 08.17.92
R E V	DESCRIPTION	ENGR DATE

TITLE: SNAP-IN CARD GUIDE



DWG IN
IN (MM)

FINAL

TOLERANCES UNLESS NOTED .XX=±.010 .XXX=±.005 FRAC=±1/64 ANG=±1'	FILE # RSFS MAT'L: SEE NOTES RE: RICHCO, INC.	DWN: P.B. DT: 04-04-94	APP: DT:	PART # SEE TABLE	PRINT TYPE CA
		RICHCO INC. PO BOX 804238, CHICAGO, 60680 (773) 539-4060			