

PART NO.	DIM. "A" REF	DIM. "B" REF
LWS-SR-1-01	.45 (11.4)	.14 (3.6)
LWS-SR-2-01	.64 (16.3)	.34 (8.6)
LWS-SR-3-01	1.03 (26.2)	.72 (18.3)
LWS-SR-4-01	1.31 (33.3)	1.00 (25.4)

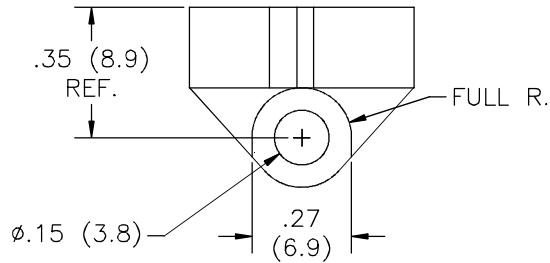

USE RICHCO RIVET NO.	FOR CHASSIS THICKNESS
SR-3535	.010-.046 (0.3-1.2)
SR-3545	.046-.081 (1.2-2.1)
SR-3550	.069-.105 (1.8-2.7)
SR-3555	.081-.120 (2.1-3.0)
SR-3560	.109-.144 (2.8-3.7)
SR-3570	.140-.180 (3.6-4.6)
SR-3580	.180-.219 (4.6-5.6)

AS MOLDED POSITION

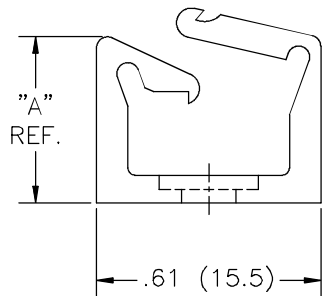

LOCKED POSITION

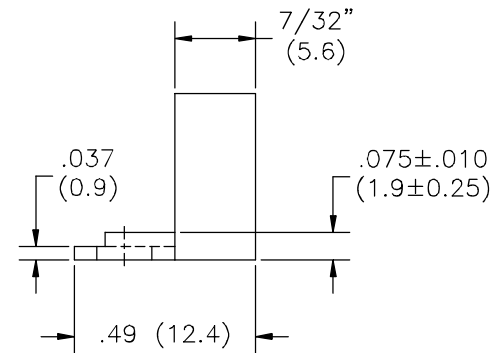
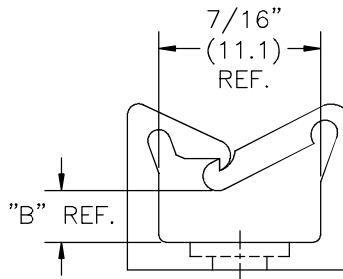

NOTES:

- MATERIAL: NYLON 6/6 (RMS-01).
COLOR: NATURAL.
- FLAME RETARDANT, NYLON (RMS-19).
COLOR: NATURAL.
AVAILABLE BY SPECIAL ORDER ONLY.

TITLE: LOCKING WIRE SADDLE, SNAP-RIVET					DWG IN IN (MM)	
TOLERANCES UNLESS NOTED .XX=±.010 .XXX=±.005 FRAC=±1/64 ANG=±1/2°	FILE # LWSSR	DWN: R.T.	APP:	PRELIMINARY		
	MAT'L: SEE NOTES	DT: 07/17/01	DT:	PART #		
	RE: RICHCO, INC.	RICHCO INC. PO BOX 804238, CHICAGO, 60680 (773) 539-4060		SEE TABLE		PRINT TYPE CA

REV	DESCRIPTION	ENGR	DATE
A	CHANGED A DIM FROM .65 TO .64 ECN 1389	DZ	12/11/13