

REV.	MODIFICATION.	DATE	DRN
01	Production Release	09/09/08	PH
02	CO 2010394	17/09/08	PH
03	CO 2010419	01/10/08	SF
04	CO 2010480	17/11/08	PH
05	CO 2010485	19/11/08	PH

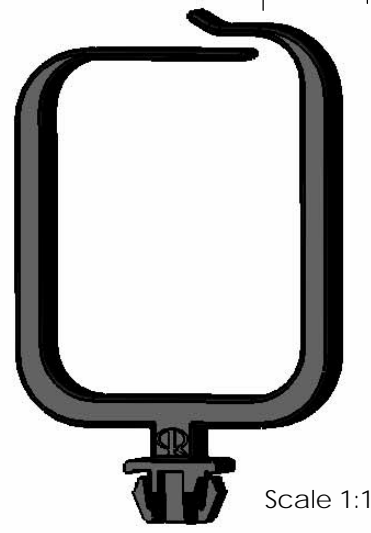
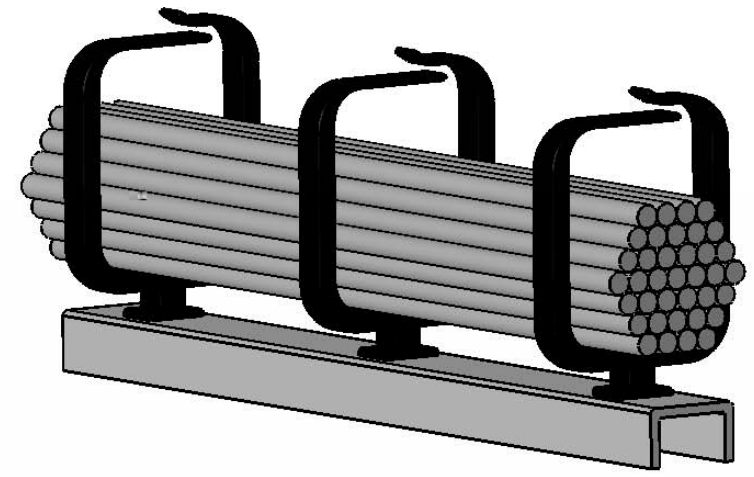
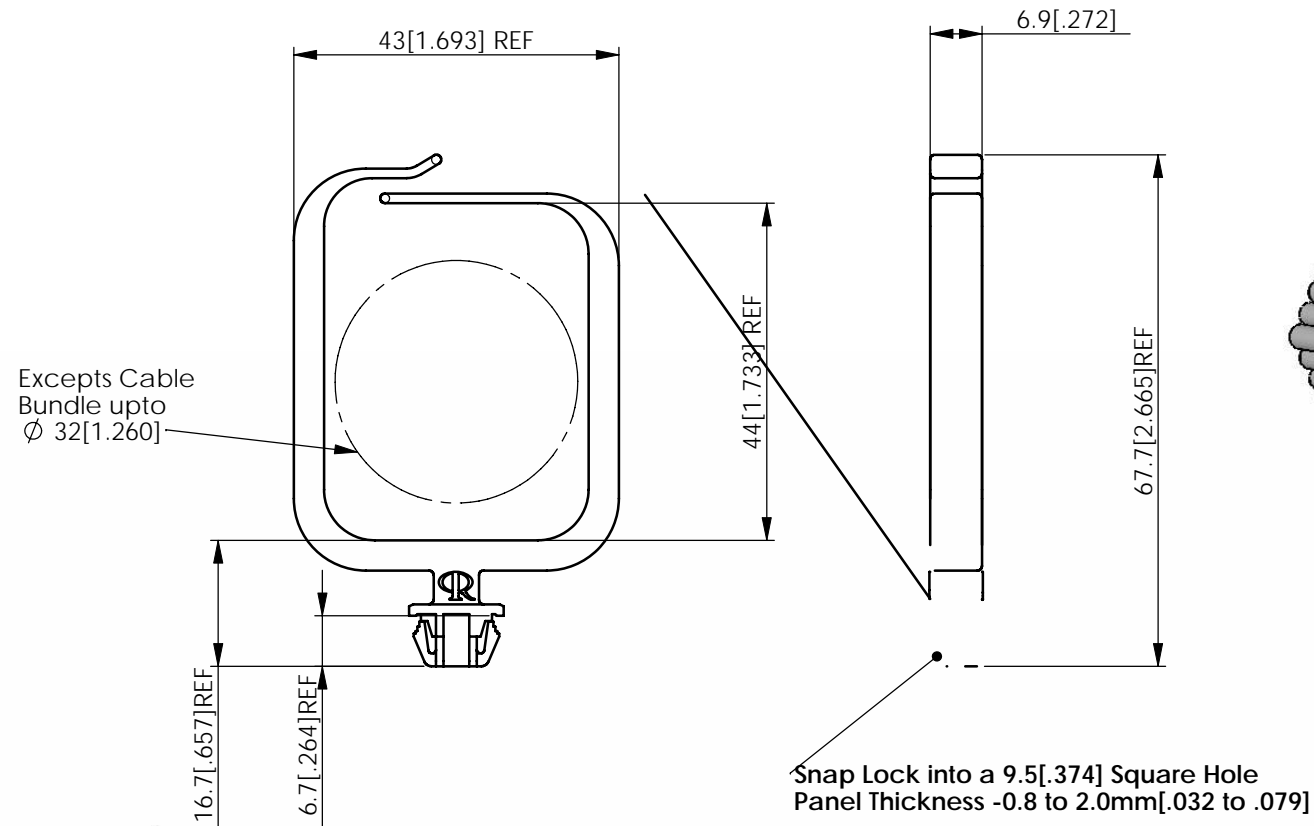

PART NUMBER	MATERIAL	COLOUR
OFNS-28-S9.5M-01	NYLON 6/6 - RMS-01	NATURAL
OFNS-28-S9.5M-19	NYLON 6/6V0 - RMS-19	

*Available by Special Order in Black - Add BK to End of Part Number to Order

INFORMATION CONTAINED IN THIS DOCUMENT IS CONFIDENTIAL TO RICHCO INTERNATIONAL Co. Ltd. AND MAY NOT BE DISCLOSED OR REPRODUCED IN WHOLE OR PART WITHOUT THEIR WRITTEN CONSENT.

Richco
 ALL DIMENSIONS IN mm
 GENERAL TOLERANCES ±0.25
 UNLESS OTHERWISE STATED
 1 DECIMAL PLACE ±0.25
 2 DECIMAL PLACES ±0.10
 ANGULAR ±1°

THIRD ANGLE

MATERIAL: SEE TABLE COLOUR: SEE TABLE

DESCRIPTION: OPTICAL FIBER NETWORK SADDLE 10mm OFF STAND PART No: SEE TABLE

DRG No: 08-087 NPR No: FN08-0004 Mass:(g) 5.2 SHEET SIZE A4

DRN PH DATE 14/05/08 CHKD TC DATE 30/05/08 SCALE NTS SHEET No. 1 OF 1