

PART NO.	A	B
REHCBS-4-01	1/4 [6.4]	.047-.063 [1.2-1.6]
REHCBS-8-01	1/2 [12.7]	.047-.079 [1.2-2.0]

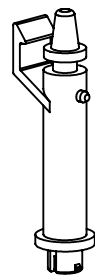
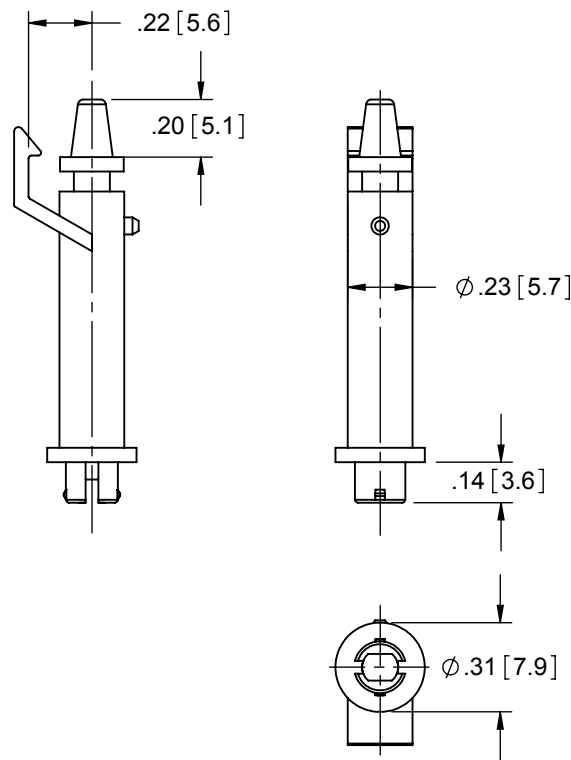
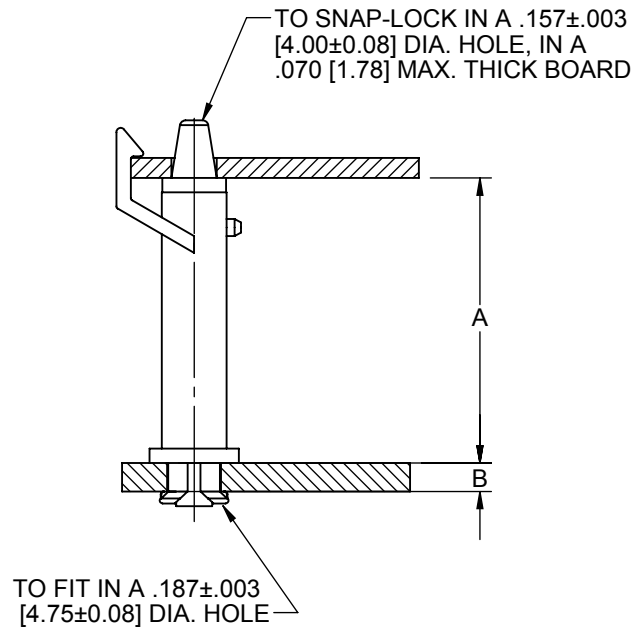

NOTES:  
 1. MATERIAL: NYLON 6/6 (RMS-01)  
 2. COLOR: NATURAL.

M			DZ 04/23/2014			TITLE: RIVET EDGE HOLD CIRCUIT BOARD SUPPORT				UNITS: INCH [mm]		FINAL	
L	SEE CO 200604 FOR CHANGES	SK 12/01/2010	CREATED USING SOLIDWORKS	FILE #: REHCBS	DWN: SK	APP: -							
K	UNOBSOLETE REHCBS-12, SEE CO 200571	SK 08/05/2010	TOLERANCES UNLESS NOTED	SHEET: 1 OF 1	SHEET SIZE: A	DT: 03/04/05	CHKD: -	PART #		SEE TABLE		PRINT TYPE	
J	SEE CO 200041 FOR CHANGES	SK 09/28/2007	.XX=±.010	RE: ESSENTRA		ESSENTRA COMPONENTS						CA	
I	SEE ECN #957 FOR CHANGES	SK 03/04/2005	.XXX=±.005										
-	SEE ENGINEERING FOR REV. A-H	----	FRAC.=±1/64										
REV.	DESCRIPTION	ENGR. DATE	ANG.=±1°										