

# 3/16 ROUND KNURLED FRONT FACE SWAGE STANDOFFS

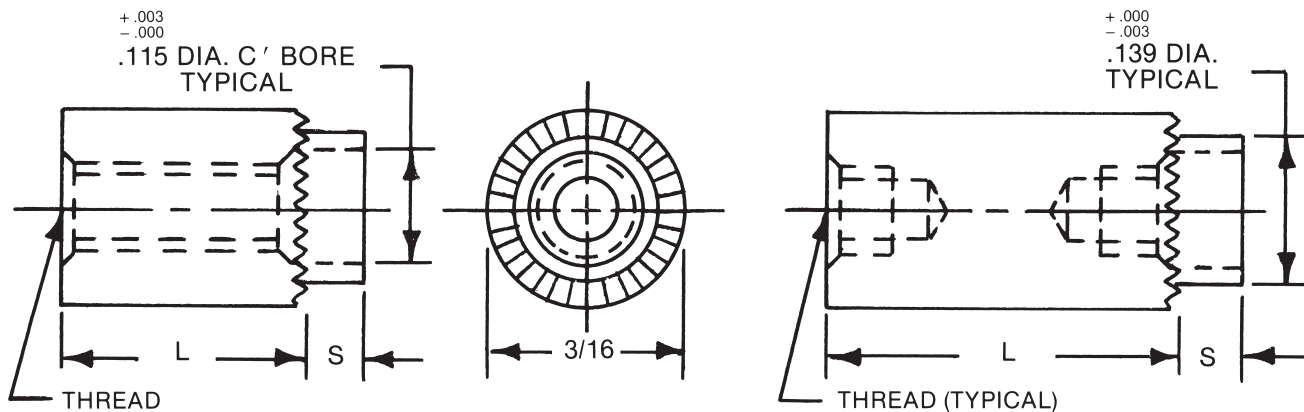

See page 10 for thread depth chart  
 See page 9 for finish codes  
 For non-standard parts contact Sales Office

L = STANDOFF LENGTH  
 S = SHANK LENGTH  
 P = BOARD THICKNESS

See page iv for installation information

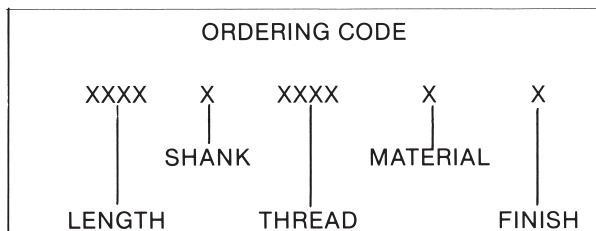

SWAGE TOOLING		
PUNCH	ANVIL	LENGTH
P-3	AR-18	1/8-3/16
	AR-19	1/4-7/16
	AR-20	1/2-11/16
	AR-21	3/4-2"

SWAGE/PANEL CODE		
± .003	S	P
.075	A	1/32
.105	B	1/16
.135	C	3/32
.165	D	1/8

LENGTH	PART NO.
1/8	7548
3/16	7549
1/4	7550
5/16	7551
3/8	7552
7/16	7553
1/2	7554
9/16	7555
5/8	7556
11/16	7557
3/4	7558
13/16	7559
7/8	7560
15/16	7561
1"	7562

LENGTH	PART NO.
1-1/16	7563
1-1/8	7564
1-3/16	7565
1-1/4	7566
1-5/16	7567
1-3/8	7568
1-7/16	7569
1-1/2	7570
1-9/16	7571
1-5/8	7572
1-11/16	7573
1-3/4	7574
1-13/16	7575
1-7/8	7576
1-15/16	7577
2"	7578

THREAD	CODE
2-56	256
4-40	440

MATERIAL	CODE	RoHS
Aluminum	AL	YES
Brass	B	YES
Stainless Steel	SS	YES
Steel	S	YES