

BY	CHK	REVISION RECORD MODIFICATIONS	DATE	REV.
WDD	DELL	RELEASE TO PRODUCTION	2006.03.27	01
WDD	DELL	CHANGE: Δ	2006.04.11	02

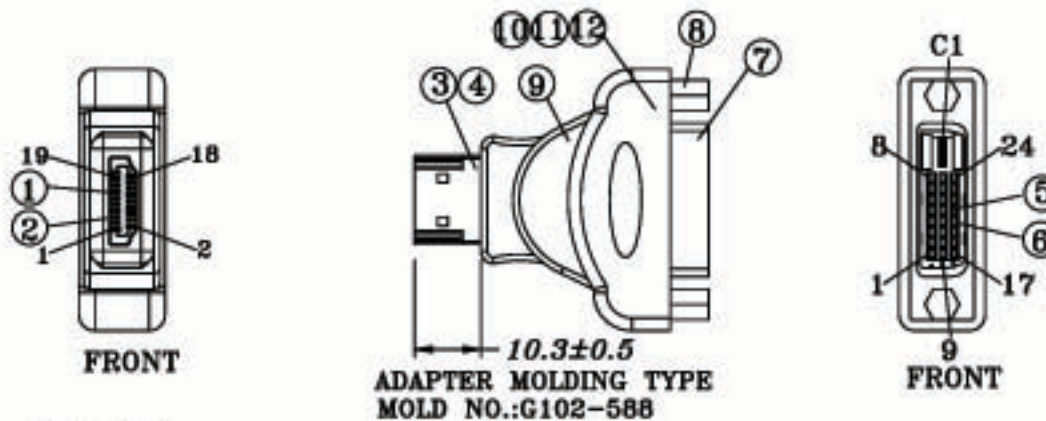

PIN OUT

HDMI/M	DVI(24+1)/F	HDMI/M	DVI(24+1)/F
3	1	10	23
1	2	12	24
2	3	11	22
6	9	15	6
4	10	16	7
5	11	18	14
9	17	17	15
7	18	19	16
8	19	SHELL	SHELL



NOTES:

1.WIRE:

28AWG(7/0.127)x1
CONDUCTOR TINNED COPPER

2.CONNECTORS HDMI MALE TO DVI(24+1) FEMALE ADAPTER

3.HOOD:ADAPTER MOLDING TYPE

4.ELECTRICAL TEST:

<1>.100% OPEN SHORT & MISS WIRE TEST.

<2>.INSULATION RESISTANCE: DC 400V 10Mohm MIN.

<3>.CONDUCTOR RESISTANCE:3 ohm MAX.

5.PACKING:1PC/BLISTER+CARD

MATERIAL LIST:

NO.	PARTS NO.	PARTS NAME	SPECIFICATION STANDARD	QTY	REMARK
①		HDMI/M-CONTACT	BRASS/GOLD PLATED	19	
②		HDMI/M-INSULATOR	PBT/BLACK	1	
Δ ③		HDMI/M-SHELL	STEEL/GOLD PLATED	1	
④		PCB		1	
⑤		DVI (24+1)P/F-CONTACT	BRONZE/GOLD FLASH SOLDER TYPE	25	
⑥		DVI (24+1)P/F-INSULATOR	THERMOPLASTIC/BLACK UL94V-0	1	
Δ ⑦		DVI (24+1)P/F-SHELL	STEEL/GOLD PLATED	1	
Δ ⑧		DVI (24+1)P/F-NUT	BRASS/GOLD PLATED	2	
⑨		JUMP WIRE	28AWG WHITE L:25mm	18	
⑩		INNER MOLD	PE NATURAL	1	
⑪		COPPER FOIL	WIDTH:18mm	1	
⑫		OUTER MOLD	45P PVC/BLACK(BK01) IN COLOR	1	
⑬		BLISTER+CARD		1SET	

HDI-9100