

THIS COPY IS PROVIDED ON A RESTRICTED BASIS AND IS NOT TO BE USED IN ANY WAY DETRIMENTAL TO THE INTERESTS OF PANDUIT CORP.

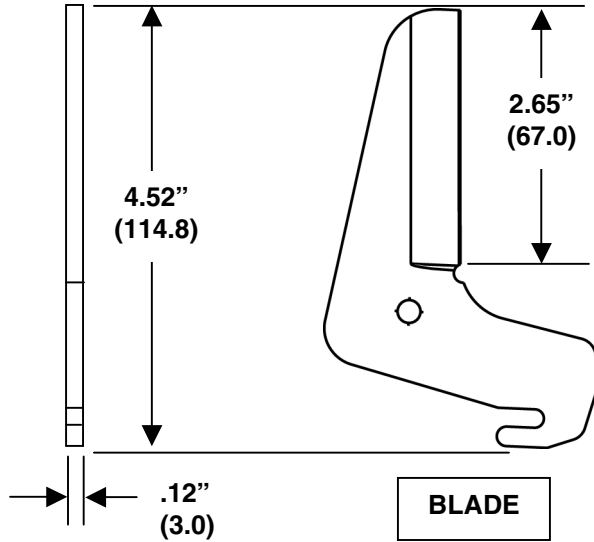

**BLADE**

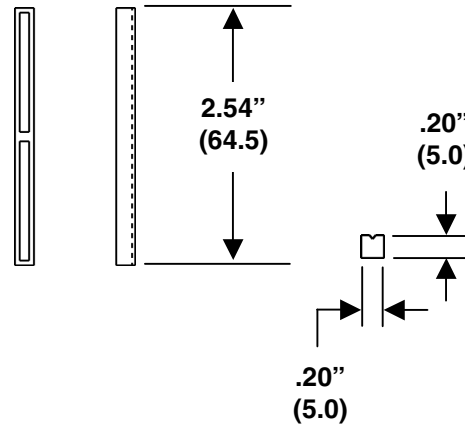

**INSERT**

Dimensions in parentheses are metric.  
All dimensions are for reference only.

**NOTES:**

**PANDUIT Part No.: DCT-BLD**  
Includes blade and insert for DCT-BLD tool.

These replacement parts are intended to be used as a cutting surface blade and insert with the DCT Duct Cutting Tool.

WEIGHT: 2.6 oz. (74.1 gr.)

**PANDUIT Part No.: DCT-RI**  
Duct cutting replacement nylon insert.

This replacement part is intended to be used as a cutting surface insert with the DCT Duct Cutting Tool.

WEIGHT: .04 oz./5 pcs.  
(11.3 gr./5 pcs.)

F:/rvusers/engdocsnew/custdwg/  
WD24986A01\_00 DCT-BLD CD.doc



CORP. TINLEY PARK, ILLINOIS

**DCT-BLD \* DUCT CUTTING REPLC. BLADE, & DCT-RI \* DUCT CUTTING REPLC. NYLON INSERT CUSTOMER DRAWING**

UNLESS OTHERWISE SPECIFIED,  
DIMENSIONAL TOLERANCES ARE:  
(.x) ± --- (.xxx) ± ---  
(.xx) ± --- ANGLES ± ---

UNLESS OTHERWISE SPECIFIED, ALL DIMENSIONS ARE GIVEN IN INCHES, THIRD ANGLE PROJECTION.

DRAWN BY:  
**BLR**

MATL:

SCALE

**NONE**

DATE:  
**4-05-05**

**BLADE:  
SPRING STEEL  
INSERT:  
NYLON**

DRAWING NO.

**WD24986A01**

DWG  
**A**  
SIZE

00	4-5-05	BLR	MBR	RELEASED; WAS LP DWG.	4153	--	DLWE	
REV	DATE	BY	CHK'D	DESCRIPTION	ECN	-R	CUST	SUP