

Snap-on frame - CES-B24-SF-PLBK - 0801647

Please be informed that the data shown in this PDF Document is generated from our Online Catalog. Please find the complete data in the user's documentation. Our General Terms of Use for Downloads are valid (<http://phoenixcontact.com/download>)



Size B24 snap-on frame including integrated mounting panel seal, for accommodating CES-B24-HFFS-PLBK or CES-B24-SFFS-PLBK sealing frames

Product Description

Snap-on frame, large

Key Commercial Data

Packing unit	10 STK
GTIN	 4 046356 674577

Technical data

Dimensions

Length	155 mm
Width	64 mm
Height	38 mm

Ambient conditions

Degree of protection	IP54
Ambient temperature (operation)	-20 °C ... 80 °C

General

Product description	Snap-on frame, large
Frame type	Snap-on frame
Material	PA
Flammability rating according to UL 94	V0
Color	black
Installation instructions	M4 mounting screw. 1.8 Nm torque
	A video tutorial on how to assemble the product can be found in the Downloads area, in the Video category.
	Leak-tightness is guaranteed with underwall and perpendicular mounting.

Standards and Regulations

Flammability rating according to UL 94	V0
--	----

Snap-on frame - CES-B24-SF-PLBK - 0801647

Classifications

eCl@ss

eCl@ss 4.0	27081002
eCl@ss 4.1	27081002
eCl@ss 5.0	27081002
eCl@ss 5.1	27081002
eCl@ss 6.0	27081002
eCl@ss 7.0	27081002
eCl@ss 8.0	27069220

ETIM

ETIM 3.0	EC000451
ETIM 4.0	EC000451
ETIM 5.0	EC000451

UNSPSC

UNSPSC 6.01	30212109
UNSPSC 7.0901	39121708
UNSPSC 11	39121708
UNSPSC 12.01	39121708
UNSPSC 13.2	39121708

Approvals

Approvals

Approvals

GL

Ex Approvals

Approvals submitted

Approval details

GL

Drawings

Snap-on frame - CES-B24-SF-PLBK - 0801647

Dimensional drawing

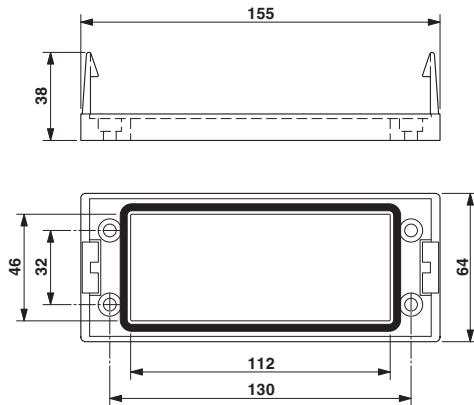

Dimensional drawing

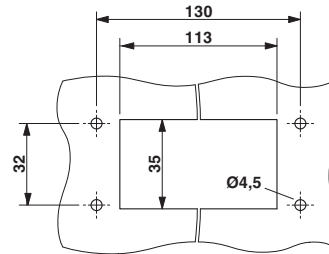

Panel cutout

Dimensional drawing

Phoenix Contact 2016 © - all rights reserved
<http://www.phoenixcontact.com>

PHOENIX CONTACT GmbH & Co. KG
Flachsmarktstr. 8
32825 Blomberg
Germany
Tel. +49 5235 300
Fax +49 5235 3 41200
<http://www.phoenixcontact.com>