

Socket - EM-DUO 120/15 - 5600461

Please be informed that the data shown in this PDF Document is generated from our Online Catalog. Please find the complete data in the user's documentation. Our General Terms of Use for Downloads are valid (<http://phoenixcontact.com/download>)



Rail-mounted dual power outlet with two 120 V AC/15 A receptacles for 35 mm DIN rail per EN 60715. For enhanced safety, the grounding pin is located at the top to prevent shorting between the hot and neutral blades. Housing color: ivory. National version: USA. Connection type: screw.

Photo shows EM-DUO 120/15



Key Commercial Data

Packing unit	1 pc
Weight per Piece (excluding packing)	245.6 g
Custom tariff number	85366990
Country of origin	United States

Technical data

Dimensions

Width	82 mm
Height	135 mm
Depth	49 mm

Ambient conditions

Ambient temperature (operation)	-35 °C ... 60 °C
---------------------------------	------------------

General

Nominal voltage U_N	125 V AC
Nominal current I_N	15 A
For country-specific use in	USA
	Canada
	Mexico
	Bahamas

Socket - EM-DUO 120/15 - 5600461

Technical data

General

	Bermuda
	Columbia
	Costa Rica
	Ecuador
	El Salvador
	Panama
	Puerto Rico
	Taiwan
	Venezuela
	Virgin Islands
Color	ivory
Insulating material	Polycarbonate & ABS blend
Standards/regulations	UL 508
	CSA 22.2

Connection data

Conductor cross section solid max.	6 mm ²
Conductor cross section flexible max.	4 mm ²
Conductor cross section AWG max.	10
Connection method	Screw connection
Stripping length	8 mm
Screw thread	M3

Standards and Regulations

Standards/regulations	UL 508
	CSA 22.2

Classifications

eCl@ss

eCl@ss 4.0	27142305
eCl@ss 4.1	27142305
eCl@ss 5.0	27143412
eCl@ss 5.1	27143412
eCl@ss 6.0	27143412
eCl@ss 7.0	27440519
eCl@ss 8.0	27142305

Socket - EM-DUO 120/15 - 5600461

Classifications

ETIM

ETIM 2.0	EC001325
ETIM 3.0	EC001325
ETIM 4.0	EC001663
ETIM 5.0	EC001663

UNSPSC

UNSPSC 6.01	30211806
UNSPSC 7.0901	39121406
UNSPSC 11	39121406
UNSPSC 12.01	39121406
UNSPSC 13.2	39121406

Approvals

Approvals

Approvals

UL Listed / cUL Listed / cULus Listed

Ex Approvals

Approvals submitted

Approval details

UL Listed 	
mm ² /AWG/kcmil	30-10
Nominal current I _N	15 A
Nominal voltage U _N	125 V

Socket - EM-DUO 120/15 - 5600461

Approvals

cUL Listed 	
mm ² /AWG/kcmil	30-10
Nominal current I _N	15 A
Nominal voltage U _N	125 V

cULus Listed 	
--	--

Drawings

Socket - EM-DUO 120/15 - 5600461

Circuit diagram

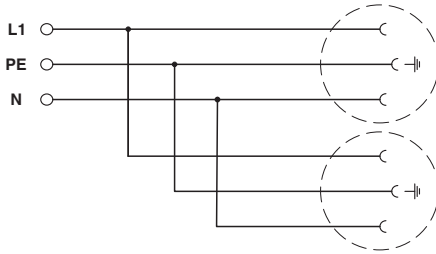

Dimensional drawing

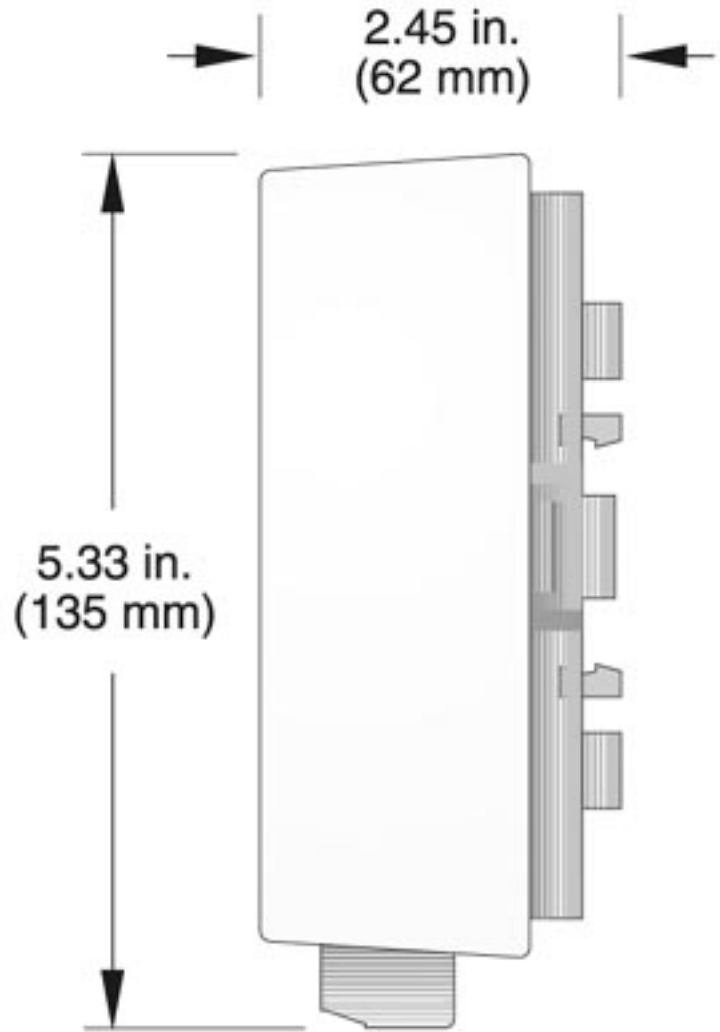

Side view

Socket - EM-DUO 120/15 - 5600461

Connection diagram

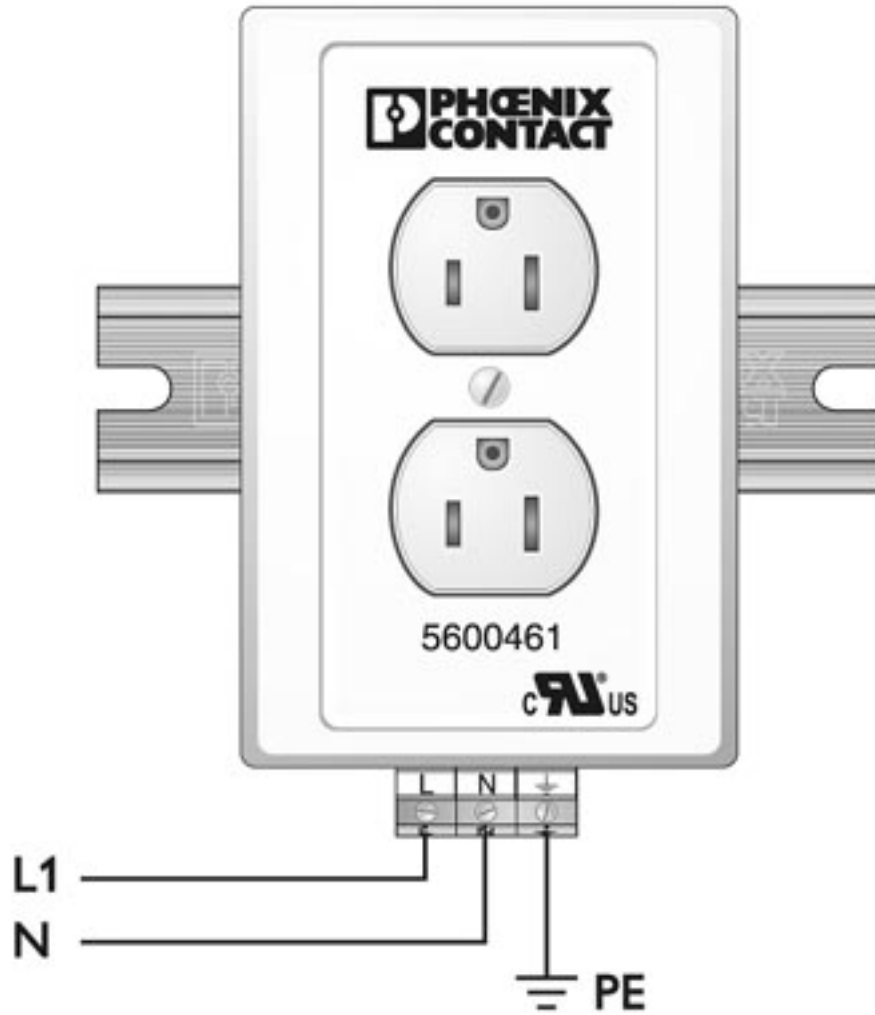

Socket - EM-DUO 120/15 - 5600461

Dimensional drawing

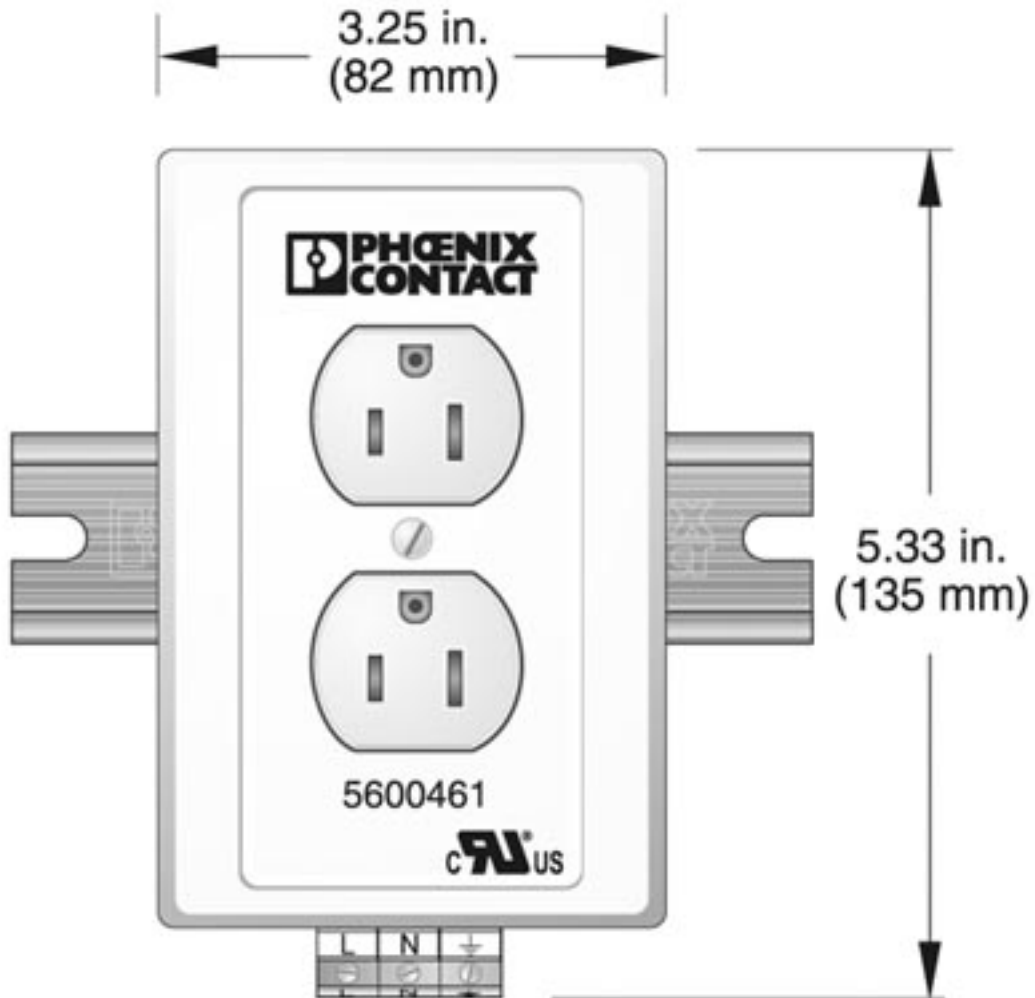

Front view

Socket - EM-DUO 120/15 - 5600461

Dimensional drawing

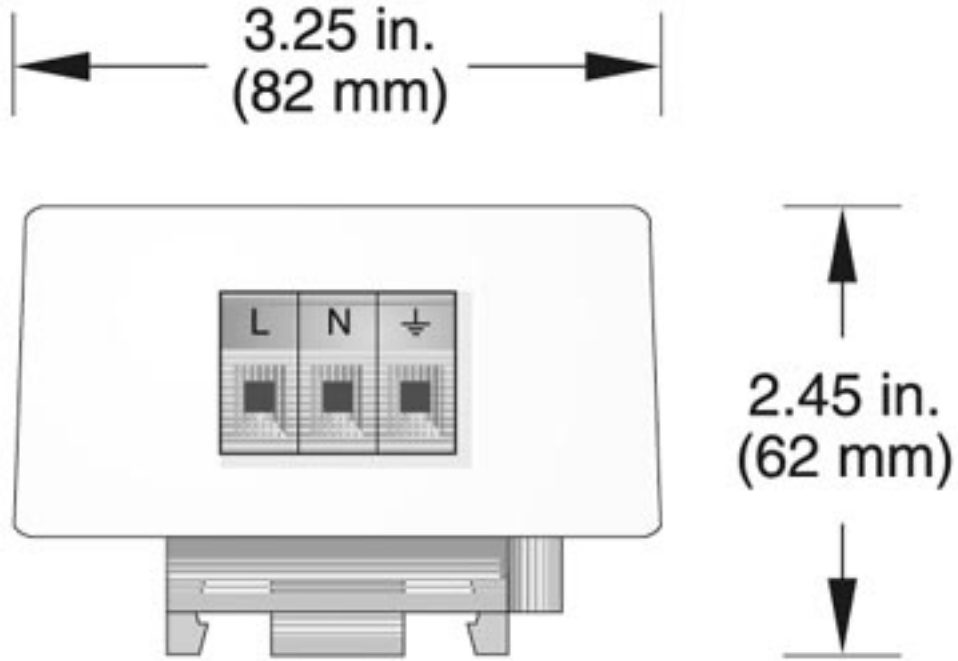

Bottom view