

Power supply unit - TRIO-PS-2G/1AC/48DC/5 - 2903159

Please be informed that the data shown in this PDF Document is generated from our Online Catalog. Please find the complete data in the user's documentation. Our General Terms of Use for Downloads are valid (<http://phoenixcontact.com/download>)



Primary-switched TRIO power supply for DIN rail mounting, input: 1-phase, output: 48 V DC / 5 A, dynamic boost, tool-free fast connection technology for solid and stranded conductors with ferrule

Product Description

TRIO POWER power supplies with standard functionality

The TRIO POWER power supply range with push-in connection has been perfected for use in machine building. All functions and the space-saving design of the single and three-phase modules are optimally tailored to the stringent requirements. Under challenging ambient conditions, the power supply units, which feature an extremely robust electrical and mechanical design, ensure the reliable supply of all loads.

Your advantages

- ✓ Save time and costs, thanks to the Push-in connection and narrow design
- ✓ Increase system availability, thanks to dynamic boost with 150% of the nominal current for five seconds
- ✓ Maximum flexibility due to the wide temperature range from -25°C to +70°C and device startup at -40°C
- ✓ Electrically robust, thanks to high electric strength
- ✓ Mechanically robust, thanks to high vibration and shock resistance



Key Commercial Data

Packing unit	1 pc
GTIN	 4 055626 255422
GTIN	4055626255422
Weight per Piece (excluding packing)	1,140.000 g
Custom tariff number	85044030
Country of origin	China

Technical data

Dimensions

Width	42 mm
-------	-------

Power supply unit - TRIO-PS-2G/1AC/48DC/5 - 2903159

Technical data

Dimensions

Height	130 mm
Depth	160 mm

Ambient conditions

Degree of protection	IP20
Ambient temperature (operation)	-25 °C ... 70 °C (> 60 °C Derating: 2.5 %/K)
Ambient temperature (start-up type tested)	-40 °C
Ambient temperature (storage/transport)	-40 °C ... 85 °C
Max. permissible relative humidity (operation)	≤ 95 % (at 25 °C, non-condensing)
Climatic class	3K3 (in acc. with EN 60721)
Degree of pollution	2
Installation height	≤ 5000 m (> 2000 m, Derating: 10 %/1000 m)

Input data

Nominal input voltage range	100 V AC ... 240 V AC 110 V DC ... 250 V DC
Input voltage range	100 V AC ... 240 V AC -15 % ... +10 % 110 V DC ... 250 V DC ±10 %
Dielectric strength maximum	≤ 300 V AC 15 s
AC frequency range	50 Hz ... 60 Hz ±10 %
Frequency range (f _N)	50 Hz ... 60 Hz # 5 Hz
Discharge current to PE	< 3.5 mA
Current consumption	2.9 A (100 V AC) 2.3 A (120 V AC) 1.2 A (230 V AC) 1.2 A (240 V AC)
Nominal power consumption	285.7 VA
Mains buffering time	typ. 15 ms (120 V AC) typ. 15 ms (230 V AC)
Input fuse	6.3 A (internal (device protection))
Recommended breaker for input protection	6 A ... 16 A (Characteristics B, C, D, K)
Power factor (cos phi)	0.91

Output data

Nominal output voltage	48 V DC ±1 %
Setting range of the output voltage (U _{Set})	36 V DC ... 55 V DC (> 48 V DC, constant capacity restricted)
Nominal output current (I _N)	5 A
Dynamic Boost (I _{Dyn.Boost})	7.5 A (5 s)
Derating	> 60 °C ... 70 °C (2.5%/K)

Power supply unit - TRIO-PS-2G/1AC/48DC/5 - 2903159

Technical data

Output data

Connection in parallel	Yes, for redundancy and increased capacity
Connection in series	yes
Feedback voltage resistance	≤ 60 V DC
Protection against overvoltage at the output (OVP)	≤ 60 V DC
Control deviation	< 1 % (change in load, static 10 % ... 90 %)
	< 3 % (Dynamic load change 10 % ... 90 %, 10 Hz)
	< 0.1 % (change in input voltage ±10 %)
Residual ripple	< 20 mV _{PP} (with nominal values)
Output power	240 W
Peak switching voltages nominal load	< 15 mV _{PP}
Maximum power dissipation in no-load condition	typ. 4 W (120 V AC)
	typ. 4.1 W (230 V AC)
Power loss nominal load max.	typ. 24.5 W (120 V AC)
	typ. 20.1 W (230 V AC)
Short-circuit current	< 7 A DC (Permanent)

General

Net weight	0.9 kg
Efficiency	typ. 90.5 % (120 V AC)
	typ. 91 % (230 V AC)
Insulation voltage input/output	3 kV AC (type test)
	1.5 kV AC (routine test)
Protection class	I (in closed control cabinet)
Degree of protection	IP20
MTBF (IEC 61709, SN 29500)	> 2000000 h (25 °C)
	> 1200000 h (40 °C)
	> 620000 h (60 °C)
Mounting position	horizontal DIN rail NS 35, EN 60715
Assembly instructions	alignable: horizontally 0 mm (≤ 40 °C) 10 mm (≤ 70 °C), vertically 50 mm

Connection data, input

Connection method	Push-in connection
Conductor cross section solid min.	0.2 mm ²
Conductor cross section solid max.	4 mm ²
Conductor cross section flexible min.	0.2 mm ²
Conductor cross section flexible max.	2.5 mm ²
Conductor cross section AWG min.	24
Conductor cross section AWG max.	12

Power supply unit - TRIO-PS-2G/1AC/48DC/5 - 2903159

Technical data

Connection data, input

Stripping length	10 mm
------------------	-------

Connection data, output

Connection method	Push-in connection
Conductor cross section solid min.	0.2 mm ²
Conductor cross section solid max.	4 mm ²
Conductor cross section flexible min.	0.2 mm ²
Conductor cross section flexible max.	2.5 mm ²
Conductor cross section AWG min.	24
Conductor cross section AWG max.	12
Stripping length	8 mm

Connection data for signaling

Connection method	Push-in connection
Conductor cross section solid min.	0.2 mm ²
Conductor cross section solid max.	1.5 mm ²
Conductor cross section flexible min.	0.2 mm ²
Conductor cross section flexible max.	1.5 mm ²
Conductor cross section AWG min.	24
Conductor cross section AWG max.	16
Stripping length	8 mm

Standards and Regulations

Electromagnetic compatibility	Conformance with EMC Directive 2014/30/EU
Noise emission	EN 55011 (EN 55022)
Noise immunity	Immunity according to EN 61000-6-1 (residential), EN 61000-6-2 (industrial)
Standards/regulations	EN 61000-4-2
Contact discharge	4 kV (Test Level 2)
Standards/regulations	EN 61000-4-3
Frequency range	80 MHz ... 1 GHz
Test field strength	10 V/m (Test Level 3)
Frequency range	1.4 GHz ... 2 GHz
Test field strength	3 V/m (Test Level 2)
Standards/regulations	EN 61000-4-4
Comments	Criterion B
Standards/regulations	EN 61000-6-3
	EN 61000-4-6
Frequency range	0.15 MHz ... 80 MHz

Power supply unit - TRIO-PS-2G/1AC/48DC/5 - 2903159

Technical data

Standards and Regulations

Voltage	10 V (Test Level 3)
Conducted noise emission	EN 55016 EN 61000-6-4 (Class A)
Standards/regulations	EN 61000-4-11
Low Voltage Directive	Conformance with Low Voltage Directive 2014/35/EC
Standard - Electrical safety	IEC 60950-1/VDE 0805 (SELV)
Standard – Safety extra-low voltage	IEC 60950-1 (SELV) and EN 60204-1 (PELV)
Standard - Safe isolation	DIN VDE 0100-410
Standard – Limitation of mains harmonic currents	EN 61000-3-2
UL approvals	UL Listed UL 508
	UL/C-UL Recognized UL 60950-1
Shock	18 ms, 30g, in each space direction (according to IEC 60068-2-27)
Vibration (operation)	DNV GL CG-0339 / Class B 2 Hz - 100 Hz resonance search, 90 min. in resonance, 2 Hz - 25 Hz, ±1.6 mm amplitude, 25 Hz - 100 Hz, 4g acceleration
Rail applications	EN 50121-4
Overvoltage category (EN 60950-1)	II
Overvoltage category (EN 62477-1)	III

Environmental Product Compliance

	Lead 7439-92-1
China RoHS	Environmentally Friendly Use Period = 25;
	For details about hazardous substances go to tab "Downloads", Category "Manufacturer's declaration"

Drawings

Power supply unit - TRIO-PS-2G/1AC/48DC/5 - 2903159

Block diagram

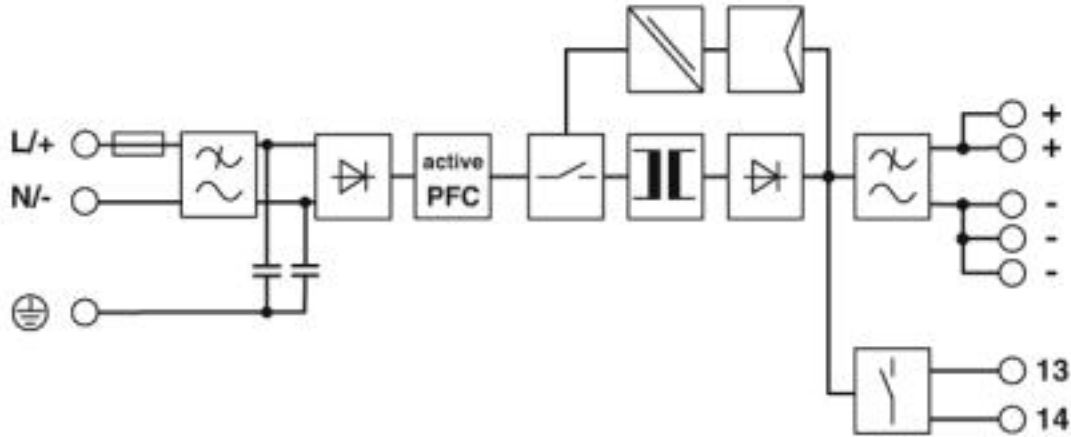

Classifications

eCl@ss

eCl@ss 4.0	27040702
eCl@ss 4.1	27040702
eCl@ss 5.0	27049002
eCl@ss 5.1	27049002
eCl@ss 6.0	27049000
eCl@ss 7.0	27049002
eCl@ss 8.0	27049002
eCl@ss 9.0	27040701

ETIM

ETIM 4.0	EC002540
ETIM 5.0	EC002540
ETIM 6.0	EC002540
ETIM 7.0	EC002540

UNSPSC

UNSPSC 13.2	39121004
-------------	----------

Approvals

Approvals

Approvals

UL Listed / UL Recognized / cUL Recognized / cUL Listed / EAC / cULus Recognized / cULus Listed

Power supply unit - TRIO-PS-2G/1AC/48DC/5 - 2903159

Approvals

Ex Approvals

UL Listed / cUL Listed / cULus Listed

Approval details

UL Listed		http://database.ul.com/cgi-bin/XYV/template/LISEXT/1FRAME/index.htm	FILE E 123528
UL Recognized		http://database.ul.com/cgi-bin/XYV/template/LISEXT/1FRAME/index.htm	FILE E 211944
cUL Recognized		http://database.ul.com/cgi-bin/XYV/template/LISEXT/1FRAME/index.htm	FILE E 211944
cUL Listed		http://database.ul.com/cgi-bin/XYV/template/LISEXT/1FRAME/index.htm	FILE E 123528
EAC			RU C- DE.A*30.B.01082
cULus Recognized			
cULus Listed			

Accessories

Accessories

Device protection

Power supply unit - TRIO-PS-2G/1AC/48DC/5 - 2903159

Accessories

Type 3 surge protection device - PLT-SEC-T3-230-FM-PT - 2907928



Type 2/3 surge protection, consisting of protective plug and base element with Push-in connection. For single-phase power supply network with integrated status indicator and remote signaling. Nominal voltage 230 V AC/DC.

Type 3 surge protection device - PLT-SEC-T3-24-FM-PT - 2907925



Type 3 surge protection, consisting of protective plug and base element, with integrated status indicator and remote signaling for single-phase power supply networks. Nominal voltage 24 V AC/DC.

Potential distributor

Potential distributors - VIP-2/SC/PDM-2/24 - 2315269



VARIOFACE module, with two equipotential busbars (P1, P2) for potential distribution, for mounting on NS 35 rails. Module width: 70.4 mm

Potential distributors - VIP-3/PT/PDM-2/24 - 2903798



VARIOFACE module with push-in connection and two equipotential busbars (P1, P2) for potential distribution, for mounting on NS 35 rails. Module width: 57.1 mm

Redundancy module

Redundancy module - TRIO-DIODE/48DC/2X10/1X20 - 2866527



Redundancy module with function monitoring, 48 V DC, 2x 10 A, 1x 20 A

Power supply unit - TRIO-PS-2G/1AC/48DC/5 - 2903159

Accessories

Phoenix Contact 2019 © - all rights reserved
<http://www.phoenixcontact.com>