

Power supply unit - TRIO-PS-2G/1AC/12DC/10 - 2903158

Please be informed that the data shown in this PDF Document is generated from our Online Catalog. Please find the complete data in the user's documentation. Our General Terms of Use for Downloads are valid (<http://phoenixcontact.com/download>)



Primary-switched TRIO POWER power supply with push-in connection for DIN rail mounting, input: 1-phase, output: 12 V DC/10 A

Product Description

TRIO POWER power supplies with standard functionality

The TRIO POWER power supply range with push-in connection has been perfected for use in machine building. All functions and the space-saving design of the single and three-phase modules are optimally tailored to the stringent requirements. Under challenging ambient conditions, the power supply units, which feature an extremely robust electrical and mechanical design, ensure the reliable supply of all loads.

Your advantages

- ✓ Save time and costs, thanks to the Push-in connection and narrow design
- ✓ Increase system availability, thanks to dynamic boost with 150% of the nominal current for five seconds
- ✓ Maximum flexibility due to the wide temperature range from -25°C to +70°C and device startup at -40°C
- ✓ Electrically robust, thanks to high electric strength
- ✓ Mechanically robust, thanks to high vibration and shock resistance



Key Commercial Data

Packing unit	1 pc
GTIN	 4 055626 255460
GTIN	4055626255460
Weight per Piece (excluding packing)	580.000 g
Custom tariff number	85044030
Country of origin	China

Technical data

Dimensions

Width	35 mm
-------	-------

Power supply unit - TRIO-PS-2G/1AC/12DC/10 - 2903158

Technical data

Dimensions

Height	130 mm
Depth	115 mm

Ambient conditions

Degree of protection	IP20
Ambient temperature (operation)	-25 °C ... 70 °C (> 60 °C Derating: 2.5 %/K)
Ambient temperature (storage/transport)	-40 °C ... 85 °C
Max. permissible relative humidity (operation)	≤ 95 % (at 25 °C, non-condensing)
Climatic class	3K3 (in acc. with EN 60721)
Degree of pollution	2
Installation height	≤ 5000 m (> 2000 m, Derating: 10 %/1000 m)

Input data

Nominal input voltage range	100 V AC ... 240 V AC
	110 V DC ... 250 V DC
Input voltage range	100 V AC ... 240 V AC -15 % ... +10 %
	99 V DC ... 275 V DC
Dielectric strength maximum	≤ 300 V AC 15 s
AC frequency range	50 Hz ... 60 Hz ±10 %
Discharge current to PE	< 0.25 mA
Current consumption	2.2 A (100 V AC)
	1.9 A (120 V AC)
	1.1 A (230 V AC)
	1.1 A (240 V AC)
Nominal power consumption	254.7 VA
Inrush current	≤ 30 A (typical)
Mains buffering time	typ. 20 ms (120 V AC)
	typ. 20 ms (230 V AC)
Input fuse	6.3 A Fast blow (internal (device protection))
Recommended breaker for input protection	6 A ... 16 A (Characteristics B, C, D, K)
Power factor (cos phi)	0.53
Type of protection	Transient surge protection
Protective circuit/component	Varistor

Output data

Nominal output voltage	12 V DC ±1 %
Setting range of the output voltage (U_{Set})	12 V DC ... 18 V DC (> 12 V DC, constant capacity restricted)
Nominal output current (I_N)	10 A
Dynamic Boost ($I_{Dyn.Boost}$)	15 A (5 s)

Power supply unit - TRIO-PS-2G/1AC/12DC/10 - 2903158

Technical data

Output data

Derating	> 60 °C ... 70 °C (2.5%/K)
Connection in parallel	Yes, for redundancy and increased capacity
Connection in series	yes
Feedback voltage resistance	< 25 V
Protection against overvoltage at the output (OVP)	≤ 22 V DC
Control deviation	< 1 % (change in load, static 10 % ... 90 %)
	< 3 % (Dynamic load change 10 % ... 90 %, 10 Hz)
	< 0.1 % (change in input voltage ±10 %)
Residual ripple	< 50 mV _{PP} (with nominal values)
Output power	120 W
Typical response time	< 1 s
Maximum power dissipation in no-load condition	< 1 W (230 V)
Power loss nominal load max.	< 15 W (230 V)

General

Net weight	0.4 kg
Efficiency	> 89 % (for 230 V AC and nominal values)
Insulation voltage input/output	3 kV AC (type test)
	1.5 kV AC (routine test)
Protection class	II (in closed control cabinet)
Degree of protection	IP20
MTBF (IEC 61709, SN 29500)	> (25 °C)
	> 1700000 h (40 °C)
	60 °C
Mounting position	horizontal DIN rail NS 35, EN 60715
Assembly instructions	alignable: horizontally 0 mm (≤ 40 °C) 10 mm (≤ 70 °C), vertically 50 mm

Connection data, input

Connection method	Push-in connection
Conductor cross section solid min.	0.2 mm ²
Conductor cross section solid max.	4 mm ²
Conductor cross section flexible min.	0.2 mm ²
Conductor cross section flexible max.	2.5 mm ²
Conductor cross section AWG min.	24
Conductor cross section AWG max.	12
Stripping length	10 mm

Connection data, output

Connection method	Push-in connection
-------------------	--------------------

Power supply unit - TRIO-PS-2G/1AC/12DC/10 - 2903158

Technical data

Connection data, output

Conductor cross section solid min.	0.2 mm ²
Conductor cross section solid max.	4 mm ²
Conductor cross section flexible min.	0.2 mm ²
Conductor cross section flexible max.	2.5 mm ²
Conductor cross section AWG min.	24
Conductor cross section AWG max.	12
Stripping length	8 mm

Connection data for signaling

Connection method	Push-in connection
Conductor cross section solid min.	0.2 mm ²
Conductor cross section solid max.	1.5 mm ²
Conductor cross section flexible min.	0.2 mm ²
Conductor cross section flexible max.	1.5 mm ²
Conductor cross section AWG min.	24
Conductor cross section AWG max.	16
Stripping length	8 mm

Standards and Regulations

Electromagnetic compatibility	Conformance with EMC Directive 2014/30/EU
Noise emission	EN 55011 (EN 55022)
Noise immunity	EN 61000-6-2:2005
Standards/regulations	EN 61000-4-2
Contact discharge	4 kV (Test Level 2)
Standards/regulations	EN 61000-4-3
Frequency range	80 MHz ... 1 GHz
Test field strength	10 V/m (Test Level 3)
Frequency range	1.4 GHz ... 2 GHz
Test field strength	3 V/m (Test Level 2)
Standards/regulations	EN 61000-4-4
Comments	Criterion B
Standards/regulations	EN 61000-6-3
	EN 61000-4-6
Frequency range	0.15 MHz ... 80 MHz
Voltage	10 V (Test Level 3)
Standards/regulations	EN 61000-4-11
Low Voltage Directive	Conformance with LV directive 2006/95/EC
Standard - Safety of transformers	EN 61558-2-16 (air clearances and creepage distances only)

Power supply unit - TRIO-PS-2G/1AC/12DC/10 - 2903158

Technical data

Standards and Regulations

Standard - Electrical safety	IEC 60950-1/VDE 0805 (SELV)
Standard – Electronic equipment for use in electrical power installations and their assembly into electrical power installations	EN 50178/VDE 0160 (PELV)
Standard – Safety extra-low voltage	IEC 60950-1 (SELV) and EN 60204-1 (PELV)
Standard - Safe isolation	DIN VDE 0100-410
Standard – Limitation of mains harmonic currents	EN 61000-3-2
UL approvals	UL Listed UL 508
	UL/C-UL Recognized UL 60950-1
Shock	18 ms, 30g, in each space direction (according to IEC 60068-2-27)
Vibration (operation)	< 15 Hz, amplitude ±2.5 mm (according to IEC 60068-2-6)
	15 Hz ... 150 Hz, 4g, 90 min.
Rail applications	EN 50121-4

Environmental Product Compliance

	Lead 7439-92-1
China RoHS	Environmentally Friendly Use Period = 25;
	For details about hazardous substances go to tab “Downloads”, Category “Manufacturer’s declaration”

Drawings

Block diagram

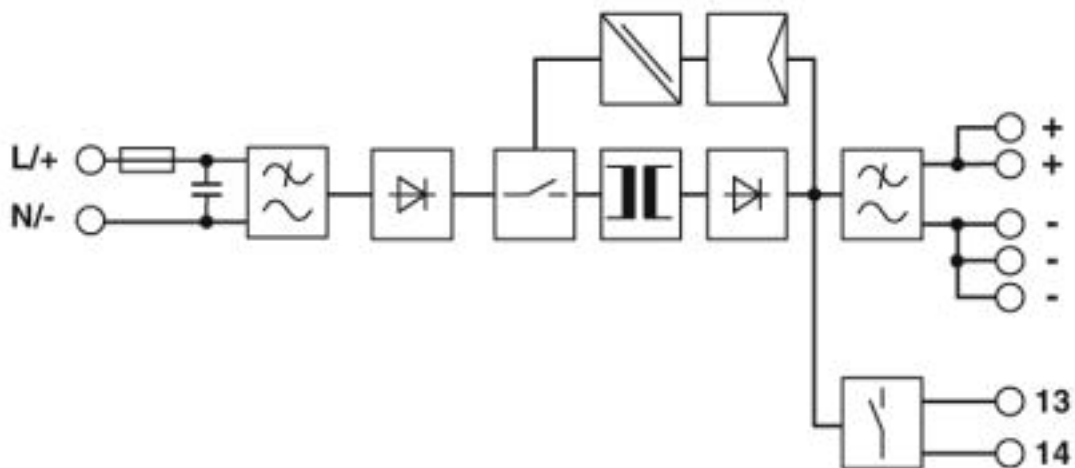

Power supply unit - TRIO-PS-2G/1AC/12DC/10 - 2903158

Classifications

eCl@ss

eCl@ss 4.0	27040702
eCl@ss 4.1	27040702
eCl@ss 5.0	27049002
eCl@ss 5.1	27049002
eCl@ss 6.0	27049000
eCl@ss 7.0	27049002
eCl@ss 8.0	27049002
eCl@ss 9.0	27040701

ETIM

ETIM 4.0	EC002540
ETIM 5.0	EC002540
ETIM 6.0	EC002540
ETIM 7.0	EC002540

UNSPSC

UNSPSC 13.2	39121004
-------------	----------

Approvals

Approvals

Approvals

UL Listed / UL Recognized / cUL Recognized / cUL Listed / EAC / cULus Recognized / cULus Listed

Ex Approvals

UL Listed / cUL Listed / cULus Listed

Approval details

UL Listed		http://database.ul.com/cgi-bin/XYV/template/LISEXT/1FRAME/index.htm	FILE E 123528
-----------	--	---	---------------

UL Recognized		http://database.ul.com/cgi-bin/XYV/template/LISEXT/1FRAME/index.htm	FILE E 211944
---------------	--	---	---------------

Power supply unit - TRIO-PS-2G/1AC/12DC/10 - 2903158

Approvals

cUL Recognized		http://database.ul.com/cgi-bin/XYV/template/LISEXT/1FRAME/index.htm	FILE E 211944
----------------	--	---	---------------

cUL Listed		http://database.ul.com/cgi-bin/XYV/template/LISEXT/1FRAME/index.htm	FILE E 123528
------------	--	---	---------------

EAC			RU C- DE.A*30.B.01082
-----	--	--	--------------------------

cULus Recognized			
------------------	--	--	--

cULus Listed			
--------------	--	--	--

Accessories

Accessories

Device protection

Type 3 surge protection device - PLT-SEC-T3-230-FM-PT - 2907928



Type 2/3 surge protection, consisting of protective plug and base element with Push-in connection. For single-phase power supply network with integrated status indicator and remote signaling. Nominal voltage 230 V AC/DC.

Type 3 surge protection device - PLT-SEC-T3-24-FM-PT - 2907925



Type 3 surge protection, consisting of protective plug and base element, with integrated status indicator and remote signaling for single-phase power supply networks. Nominal voltage 24 V AC/DC.

