

Power supply unit - TRIO-PS-2G/1AC/24DC/10 - 2903149

Please be informed that the data shown in this PDF Document is generated from our Online Catalog. Please find the complete data in the user's documentation. Our General Terms of Use for Downloads are valid (<http://phoenixcontact.com/download>)



Primary-switched TRIO POWER power supply with push-in connection for DIN rail mounting, input: single phase, output: 24 V DC/10 A

Product Description

TRIO POWER power supplies with standard functionality

The TRIO POWER power supply range with push-in connection has been perfected for use in machine building. All functions and the space-saving design of the single and three-phase modules are optimally tailored to the stringent requirements. Under challenging ambient conditions, the power supply units, which feature an extremely robust electrical and mechanical design, ensure the reliable supply of all loads.

Your advantages

- ✓ Save time and costs, thanks to the Push-in connection and narrow design
- ✓ Increase system availability, thanks to dynamic boost with 150% of the nominal current for five seconds
- ✓ Maximum flexibility due to the wide temperature range from -25°C to +70°C and device startup at -40°C
- ✓ Rugged design



Key Commercial Data

Packing unit	1 pc
GTIN	 4 046356 960854
GTIN	4046356960854
Weight per Piece (excluding packing)	1,200.000 g
Custom tariff number	85044030
Country of origin	China

Technical data

Dimensions

Width	42 mm
Height	130 mm

Power supply unit - TRIO-PS-2G/1AC/24DC/10 - 2903149

Technical data

Dimensions

Depth	160 mm
-------	--------

Ambient conditions

Degree of protection	IP20
Ambient temperature (operation)	-25 °C ... 70 °C (> 60 °C Derating: 2.5 %/K)
Ambient temperature (start-up type tested)	-40 °C
Ambient temperature (storage/transport)	-40 °C ... 85 °C
Max. permissible relative humidity (operation)	≤ 95 % (at 25 °C, non-condensing)
Climatic class	3K3 (in acc. with EN 60721)
Degree of pollution	2
Installation height	≤ 5000 m (> 2000 m, Derating: 10 %/1000 m)

Input data

Nominal input voltage range	100 V AC ... 240 V AC
	110 V DC ... 250 V DC
Input voltage range	100 V AC ... 240 V AC -15 % ... +10 %
	110 V DC ... 250 V DC -10 % ... +10 %
Dielectric strength maximum	300 V AC 15 s
AC frequency range	50 Hz ... 60 Hz ±10 %
Discharge current to PE	< 3.5 mA
Current consumption	3.1 A (100 V AC)
	2.4 A (120 V AC)
	1.3 A (230 V AC)
	1.4 A (240 V AC)
Nominal power consumption	285 VA
Inrush current	≤ 25 A (typical)
Mains buffering time	typ. 15 ms (120 V AC)
	typ. 20 ms (230 V AC)
Input fuse	6.3 A (internal (device protection))
Recommended breaker for input protection	6 A ... 16 A (Characteristics B, C, D, K)
Power factor (cos phi)	0.93
Type of protection	Transient surge protection
Protective circuit/component	Varistor

Output data

Nominal output voltage	24 V DC ±1 %
Setting range of the output voltage (U _{Set})	24 V DC ... 28 V DC (constant capacity)
Nominal output current (I _N)	10 A
Dynamic Boost (I _{Dyn.Boost})	15 A (5 s)

Power supply unit - TRIO-PS-2G/1AC/24DC/10 - 2903149

Technical data

Output data

Derating	> 60 °C ... 70 °C (2.5%/K)
Connection in parallel	Yes, for redundancy and increased capacity
Connection in series	yes
Feedback voltage resistance	≤ 35 V DC
Protection against overvoltage at the output (OVP)	≤ 30 V DC
Control deviation	< 1 % (change in load, static 10 % ... 90 %)
	< 3 % (Dynamic load change 10 % ... 90 %, 10 Hz)
	< 0.1 % (change in input voltage ±10 %)
Residual ripple	< 10 mV _{PP} (with nominal values)
Output power	240 W
Typical response time	< 1 s
Maximum power dissipation in no-load condition	< 5.1 W (230 V)
Power loss nominal load max.	< 25 W

General

Net weight	1 kg
Efficiency	> 91 % (for 230 V AC and nominal values)
Insulation voltage input/output	3 kV AC (type test)
	1.5 kV AC (routine test)
Protection class	I (in closed control cabinet)
Degree of protection	IP20
MTBF (IEC 61709, SN 29500)	> 1800000 h (25 °C)
	> 1000000 h (40 °C)
	> 480000 h (60 °C)
Mounting position	horizontal DIN rail NS 35, EN 60715
Assembly instructions	alignable: horizontally 0 mm (≤ 40 °C) 10 mm (≤ 70 °C), vertically 50 mm

Connection data, input

Connection method	Push-in connection
Conductor cross section solid min.	0.2 mm ²
Conductor cross section solid max.	4 mm ²
Conductor cross section flexible min.	0.2 mm ²
Conductor cross section flexible max.	2.5 mm ²
Conductor cross section AWG min.	24
Conductor cross section AWG max.	12
Stripping length	10 mm

Connection data, output

Connection method	Push-in connection
-------------------	--------------------

Power supply unit - TRIO-PS-2G/1AC/24DC/10 - 2903149

Technical data

Connection data, output

Conductor cross section solid min.	0.2 mm ²
Conductor cross section solid max.	4 mm ²
Conductor cross section flexible min.	0.2 mm ²
Conductor cross section flexible max.	2.5 mm ²
Conductor cross section AWG min.	24
Conductor cross section AWG max.	12
Stripping length	8 mm

Connection data for signaling

Connection method	Push-in connection
Conductor cross section solid min.	0.2 mm ²
Conductor cross section solid max.	1.5 mm ²
Conductor cross section flexible min.	0.2 mm ²
Conductor cross section flexible max.	1.5 mm ²
Conductor cross section AWG min.	24
Conductor cross section AWG max.	16
Stripping length	8 mm

Standards

EMC requirements for noise immunity	EN 61000-6-1
	EN 61000-6-2
EMC requirements for noise emission	EN 61000-6-3
	EN 61000-6-4
Standard - Safety of transformers	EN 61558-2-16 (air clearances and creepage distances only)
Standard - Electrical safety	IEC 60950-1/VDE 0805 (SELV)
Standard – Electronic equipment for use in electrical power installations and their assembly into electrical power installations	EN 50178/VDE 0160 (PELV)
Standard – Safety extra-low voltage	IEC 60950-1 (SELV) and EN 60204-1 (PELV)
Standard - Safe isolation	DIN VDE 0100-410
Standard – Limitation of mains harmonic currents	EN 61000-3-2
Rail applications	EN 50121-4

Conformance/approvals

UL approvals	UL Listed UL 508
	UL/C-UL Recognized UL 60950-1

EMC data

Electromagnetic compatibility	Conformance with EMC Directive 2014/30/EU
Low Voltage Directive	Conformance with LV directive 2006/95/EC
Electrostatic discharge	EN 61000-4-2

Power supply unit - TRIO-PS-2G/1AC/24DC/10 - 2903149

Technical data

EMC data

Contact discharge	6 kV (Test Level 4)
Discharge in air	8 kV (Test Level 4)
Electromagnetic HF field	EN 61000-4-3
Frequency range	80 MHz ... 1 GHz
Test field strength	10 V/m (Test Level 3)
Frequency range	1 GHz ... 2 GHz
Test field strength	10 V/m (Test Level 3)
Frequency range	2 GHz ... 3 GHz
Test field strength	10 V/m (Test Level 3)
Comments	Criterion A
Fast transients (burst)	EN 61000-4-4
Input	4 kV (Test Level 4 - asymmetrical)
Output	2 kV (Test Level 3 - asymmetrical)
Signal	1 kV (Test Level 2 - asymmetrical)
Comments	Criterion A
Surge voltage load (surge)	EN 61000-4-5
Input	3 kV (Test Level 3 - symmetrical)
	6 kV (Test Level 4 - asymmetrical)
Output	1 kV (Test Level 2 - symmetrical)
	2 kV (Test Level 1 - asymmetrical)
Signal	1 kV (Test Level 2 - asymmetrical)
Comments	Criterion B
Conducted interference	EN 61000-4-6
Frequency range	0.15 MHz ... 80 MHz
Voltage	10 V (Test Level 3)
Comments	Criterion A
Criterion A	Normal operating behavior within the specified limits.
Criterion B	Temporary impairment to operational behavior that is corrected by the device itself.

Environmental Product Compliance

	Lead 7439-92-1
China RoHS	Environmentally Friendly Use Period = 25;
	For details about hazardous substances go to tab "Downloads", Category "Manufacturer's declaration"

Drawings

Power supply unit - TRIO-PS-2G/1AC/24DC/10 - 2903149

Block diagram

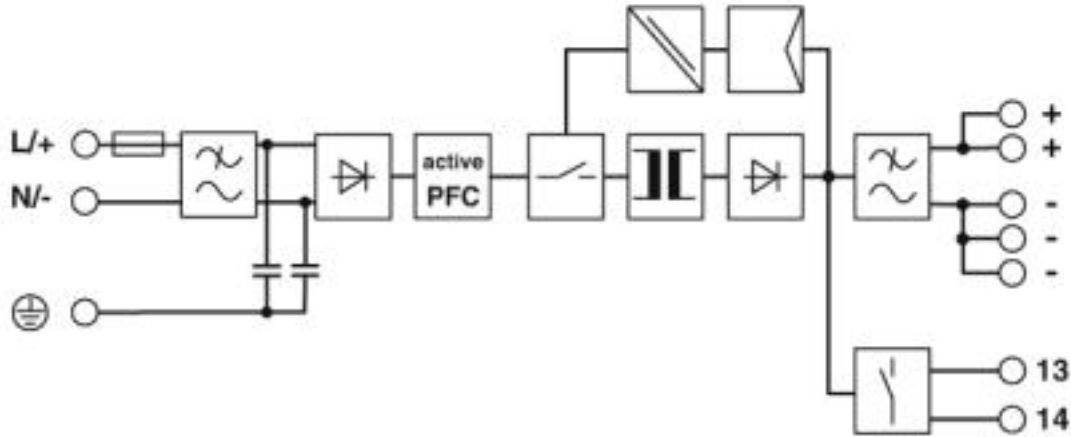

Classifications

eCl@ss

eCl@ss 4.0	27040700
eCl@ss 4.1	27040700
eCl@ss 5.0	27049000
eCl@ss 5.1	27049000
eCl@ss 6.0	27049000
eCl@ss 7.0	27049002
eCl@ss 8.0	27049002
eCl@ss 9.0	27040701

ETIM

ETIM 4.0	EC002540
ETIM 5.0	EC002540
ETIM 6.0	EC002540
ETIM 7.0	EC002540

UNSPSC

UNSPSC 13.2	39121004
-------------	----------

Approvals

Approvals

Power supply unit - TRIO-PS-2G/1AC/24DC/10 - 2903149

Approvals

Approvals

UL Listed / UL Recognized / cUL Recognized / IECEE CB Scheme / cUL Listed / EAC / DNV GL / UL Recognized / IECEE CB Scheme / UL Listed / cUL Listed / cUL Recognized / DNV GL / EAC

Ex Approvals

UL Listed / cUL Listed / UL Listed / cUL Listed / cULus Listed

Approval details

UL Listed		http://database.ul.com/cgi-bin/XYV/template/LISEXT/1FRAME/index.htm	FILE E 123528
UL Recognized		http://database.ul.com/cgi-bin/XYV/template/LISEXT/1FRAME/index.htm	FILE E 211944
cUL Recognized		http://database.ul.com/cgi-bin/XYV/template/LISEXT/1FRAME/index.htm	FILE E 211944
IECEE CB Scheme		http://www.iecee.org/	DK-45300-A1-UL
cUL Listed		http://database.ul.com/cgi-bin/XYV/template/LISEXT/1FRAME/index.htm	FILE E 123528
EAC			RU C-DE.A*30.B.01082
DNV GL		https://approvalfinder.dnvgl.com/	TAA00000BM

Power supply unit - TRIO-PS-2G/1AC/24DC/10 - 2903149

Approvals

UL Recognized		http://database.ul.com/cgi-bin/XYV/template/LISEXT/1FRAME/index.htm	FILE E 211944
IECEE CB Scheme		http://www.iecee.org/	DK-45300-A1-UL
UL Listed		http://database.ul.com/cgi-bin/XYV/template/LISEXT/1FRAME/index.htm	FILE E 123528
cUL Listed		http://database.ul.com/cgi-bin/XYV/template/LISEXT/1FRAME/index.htm	FILE E 123528
cUL Recognized		http://database.ul.com/cgi-bin/XYV/template/LISEXT/1FRAME/index.htm	FILE E 211944
DNV GL		https://approvalfinder.dnvgl.com/	TAA00000BM
EAC			RU C- DE.A*30.B.01082

Accessories

Accessories

Device circuit breakers

Electronic device circuit breaker - CBM E4 24DC/0.5-10A NO-R - 2905743



Multi-channel, electronic device circuit breaker with active current limitation for protecting four loads at 24 V DC in the event of overload and short circuit. With nominal current assistant and electronic locking of the set nominal currents. For installation on DIN rails.

Power supply unit - TRIO-PS-2G/1AC/24DC/10 - 2903149

Accessories

Electronic device circuit breaker - CBM E8 24DC/0.5-10A NO-R - 2905744



Multi-channel, electronic device circuit breaker with active current limitation for protecting eight loads at 24 V DC in the event of overload and short circuit. With nominal current assistant and electronic locking of the set nominal currents. For installation on DIN rails.

Electronic device circuit breaker - CBMC E4 24DC/1-4A NO - 2906031



Multi-channel electronic device circuit breaker for protecting four loads at 24 V DC in the event of overload and short circuit. With electronic locking of the set nominal currents. For installation on DIN rails.

Electronic device circuit breaker - CBMC E4 24DC/1-10A NO - 2906032



Multi-channel electronic device circuit breaker for protecting four loads at 24 V DC in the event of overload and short circuit. With electronic locking of the set nominal currents. For installation on DIN rails.

Device protection

Type 3 surge protection device - PLT-SEC-T3-230-FM-PT - 2907928



Type 2/3 surge protection, consisting of protective plug and base element with Push-in connection. For single-phase power supply network with integrated status indicator and remote signaling. Nominal voltage 230 V AC/DC.

Type 3 surge protection device - PLT-SEC-T3-24-FM-PT - 2907925



Type 3 surge protection, consisting of protective plug and base element, with integrated status indicator and remote signaling for single-phase power supply networks. Nominal voltage 24 V AC/DC.

Power supply unit - TRIO-PS-2G/1AC/24DC/10 - 2903149

Accessories

Potential distributor

Potential distributors - VIP-2/SC/PDM-2/24 - 2315269



VARIOFACE module, with two equipotential busbars (P1, P2) for potential distribution, for mounting on NS 35 rails.
Module width: 70.4 mm

Potential distributors - VIP-3/PT/PDM-2/24 - 2903798



VARIOFACE module with push-in connection and two equipotential busbars (P1, P2) for potential distribution, for mounting on NS 35 rails. Module width: 57.1 mm
