

Redundancy module - TRIO-DIODE/48DC/2X10/1X20 - 2866527

Please be informed that the data shown in this PDF Document is generated from our Online Catalog. Please find the complete data in the user's documentation. Our General Terms of Use for Downloads are valid (<http://phoenixcontact.com/download>)



Redundancy module with function monitoring, 48 V DC, 2x 10 A, 1x 20 A

Product Description

TRIO DIODE is the DIN-rail mountable redundancy module from the TRIO POWER product range.

Using the redundancy module, it is possible for two power supply units of the same type connected in parallel on the output side to increase performance or for redundancy to be 100 % isolated from one another.

Redundant systems are used in systems that place particularly high demands on operational reliability. The connected power supply units must be large enough that the total current requirements of all loads can be met by one power supply unit. The redundant structure of the power supply therefore ensures long-term, permanent system availability.

In the event of an internal device fault or failure of the mains power supply on the primary side, the other device automatically takes over the entire power supply of the loads without interruption. The floating signal contact and LED immediately indicate the loss of redundancy.

Your advantages

- Save energy
- Permanent monitoring of redundancy
- Consistent redundancy up to the load



Key Commercial Data

Packing unit	1 pc
GTIN	 4 046356 562973
GTIN	4046356562973
Weight per Piece (excluding packing)	540.000 g
Custom tariff number	85049091
Country of origin	China

Technical data

Dimensions

Redundancy module - TRIO-DIODE/48DC/2X10/1X20 - 2866527

Technical data

Dimensions

Width	32 mm
Height	130 mm
Depth	115 mm

Ambient conditions

Degree of protection	IP20
Ambient temperature (operation)	-25 °C ... 70 °C (> 55 °C derating : 2.5%/K)
Ambient temperature (storage/transport)	-40 °C ... 85 °C
Max. permissible relative humidity (operation)	≤ 95 % (at 25 °C, non-condensing)
Climatic class	3K3 (in acc. with EN 60721)
Degree of pollution	2

Input data

Nominal input voltage range	48 V DC
Input voltage range	30 V DC ... 56 V DC
Nominal input current	2x 10 A (-25 °C ... 55 °C)
	1x 20 A (-25 °C ... 55 °C)
Maximum input current	2x 15 A (-25 °C ... 40 °C)
	1x 30 A (-25 °C ... 40 °C)

Output data

Nominal output voltage	47.3 V DC (Input/output voltage drop of 48 V ... 0.7 V)
Nominal output current (I _N)	20 A (Increasing power)
	10 A (Redundancy)
Derating	55 °C ... 70 °C (2.5%/K)
Connection in series	No
Maximum power dissipation in no-load condition	7 W (I _{OUT} = 10 A)
Power loss nominal load max.	14 W (I _{OUT} = 20 A)

General

Net weight	0.37 kg
Efficiency	> 97 %
Protection class	III
Degree of protection	IP20
	> 10000000 h (40 °C)
Mounting position	horizontal DIN rail NS 35, EN 60715
Assembly instructions	alignable: horizontally 0 mm, vertically 50 mm

Connection data, input

Connection method	Screw connection
-------------------	------------------

Redundancy module - TRIO-DIODE/48DC/2X10/1X20 - 2866527

Technical data

Connection data, input

Conductor cross section solid min.	0.2 mm ²
Conductor cross section solid max.	2.5 mm ²
Conductor cross section flexible min.	0.2 mm ²
Conductor cross section flexible max.	2.5 mm ²
Conductor cross section AWG min.	24
Conductor cross section AWG max.	14
Stripping length	9 mm
Screw thread	M2,5

Connection data, output

Connection method	Screw connection
Conductor cross section solid min.	0.5 mm ²
Conductor cross section solid max.	6 mm ²
Conductor cross section flexible min.	0.5 mm ²
Conductor cross section flexible max.	4 mm ²
Conductor cross section AWG min.	20
Conductor cross section AWG max.	10
Stripping length	14 mm
Screw thread	M3

Connection data for signaling

Conductor cross section solid min.	0.2 mm ²
Conductor cross section solid max.	2.5 mm ²
Conductor cross section flexible min.	0.2 mm ²
Conductor cross section flexible max.	2.5 mm ²
Conductor cross section AWG min.	24
Conductor cross section AWG max.	14
Screw thread	M2,5

Standards and Regulations

Electromagnetic compatibility	Conformance with EMC Directive 2014/30/EU
Connection in acc. with standard	CUL
Standards/regulations	EN 61000-4-2
Contact discharge	4 kV (Test Level 2)
Standards/regulations	EN 61000-4-3
Frequency range	80 MHz ... 1 GHz
Test field strength	10 V/m (Test Level 3)
Frequency range	1.4 GHz ... 2 GHz
Test field strength	3 V/m (Test Level 2)

Redundancy module - TRIO-DIODE/48DC/2X10/1X20 - 2866527

Technical data

Standards and Regulations

Standards/regulations	EN 61000-4-4
Comments	Criterion B
Standards/regulations	EN 61000-6-3
	EN 61000-4-6
Frequency range	0.15 MHz ... 80 MHz
Voltage	10 V (Test Level 3)
Low Voltage Directive	Conformance with LV directive 2006/95/EC
Standard - Electrical safety	EN 60950-1/VDE 0805 (SELV)
Standard - Electronic equipment for use in electrical power installations and their assembly into electrical power installations	EN 50178/VDE 0160 (PELV)
Standard - Safety extra-low voltage	IEC 60950-1 (SELV) and EN 60204-1 (PELV)
Standard - Safe isolation	DIN VDE 0100-410
Standard - Protection against shock currents, basic requirements for protective separation in electrical equipment	EN 50178
UL approvals	UL/C-UL listed UL 508
	UL/C-UL Recognized UL 60950-1
Shock	15g in all directions in acc. with IEC 60068-2-27
Vibration (operation)	< 15 Hz, amplitude ± 2.5 mm
	15 Hz ... 150 Hz, 2.3g $t_r = 90$ min.

Drawings

Block diagram

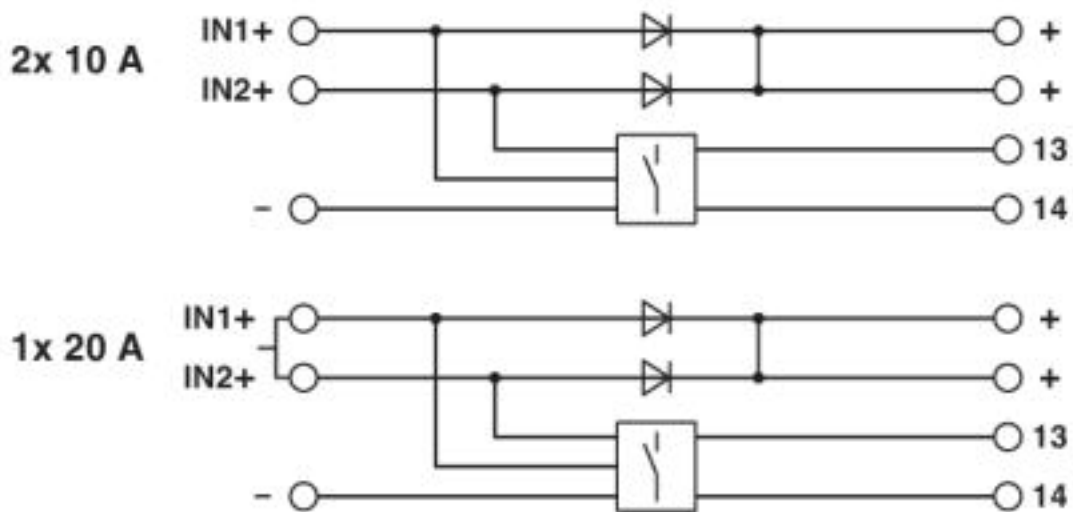

Redundancy module - TRIO-DIODE/48DC/2X10/1X20 - 2866527

Classifications

eCl@ss

eCl@ss 4.0	27250300
eCl@ss 4.1	27250300
eCl@ss 5.0	27371000
eCl@ss 5.1	27371000
eCl@ss 6.0	27371000
eCl@ss 7.0	27371010
eCl@ss 8.0	27371010
eCl@ss 9.0	27371010

ETIM

ETIM 3.0	EC001039
ETIM 4.0	EC002540
ETIM 5.0	EC000683
ETIM 6.0	EC000683
ETIM 7.0	EC000683

UNSPSC

UNSPSC 6.01	30211502
UNSPSC 7.0901	39121004
UNSPSC 11	39121004
UNSPSC 12.01	39121004
UNSPSC 13.2	39121004

Approvals

Approvals

Approvals

UL Listed / UL Recognized / cUL Recognized / cUL Listed / EAC / EAC / cULus Recognized / cULus Listed

Ex Approvals

Approval details

UL Listed		http://database.ul.com/cgi-bin/XYV/template/LISEXT/1FRAME/index.htm	FILE E 123528
-----------	---	---	---------------

Redundancy module - TRIO-DIODE/48DC/2X10/1X20 - 2866527

Approvals

UL Recognized		http://database.ul.com/cgi-bin/XYV/template/LISEXT/1FRAME/index.htm	FILE E 211944
---------------	--	---	---------------

cUL Recognized		http://database.ul.com/cgi-bin/XYV/template/LISEXT/1FRAME/index.htm	FILE E 211944
----------------	--	---	---------------

cUL Listed		http://database.ul.com/cgi-bin/XYV/template/LISEXT/1FRAME/index.htm	FILE E 123528
------------	--	---	---------------

EAC			EAC-Zulassung
-----	--	--	---------------

EAC			RU C- DE.A*30.B.01082
-----	--	--	--------------------------

cULus Recognized			
------------------	--	--	--

cULus Listed			
--------------	--	--	--