

## Monitoring relay - EMD-FL-C-10 - 2866022

Please be informed that the data shown in this PDF Document is generated from our Online Catalog. Please find the complete data in the user's documentation. Our General Terms of Use for Downloads are valid (<http://phoenixcontact.com/download>)



Monitoring relay for monitoring 1-phase currents of 0...10 A AC/DC, overcurrent/undercurrent or window, error memory, wide-range power supply unit, 2 PDTs

### Product Description

Increasingly higher demands are being placed on safety and system availability - across all sectors. Processes are becoming more and more complex, not only in mechanical engineering and the chemical industry, but also in plant and automation technology. Demands on power engineering are also increasing constantly.

Error-free and therefore cost-effective operation can only be achieved through continuous monitoring of important network and system parameters. Electronic monitoring relays in the EMD series are available for a wide range of monitoring tasks to avoid the consequences of errors or to keep them within limits.

The operating states are indicated using colored LEDs, errors that may occur can be sent to a control system via a floating contact or can shut down a part of the system. Some device versions are equipped with startup and response delays in order to briefly tolerate measured values outside the set monitoring range.

### Your advantages

- Variable supply voltage range
- Adjustable via potentiometer on the front
- Separately adjustable startup and response delays



### Key Commercial Data

Packing unit	1 pc
GTIN	 4 017918 975005
GTIN	4017918975005
Weight per Piece (excluding packing)	170.200 g
Custom tariff number	85364900
Country of origin	Austria

### Technical data

Note

# Monitoring relay - EMD-FL-C-10 - 2866022

## Technical data

### Note

Utilization restriction	EMC: class A product, see manufacturer's declaration in the download area
-------------------------	---

### Dimensions

Width	22.5 mm
Height	90 mm
Depth	113 mm

### Ambient conditions

Ambient temperature (operation)	-25 °C ... 55 °C
	-25 °C ... 40 °C (corresponds to UL 508)
Ambient temperature (storage/transport)	-25 °C ... 70 °C
Permissible humidity (operation)	15 % ... 85 %
Degree of protection	IP40 (Housing)
	IP20 (Connection terminal blocks)
Noise immunity	EN 61000-6-2

### Input data

Input current range	0 mA ... 100 mA (Connection terminals: I1 and GND)
	0 A ... 1 A (Connection terminals: I2 and GND)
	0 A ... 10 A (Connection terminals: I3 and GND)
Overload capacity	800 mA (at $I_N = 100$ mA)
	3 A (at $I_N = 1$ A)
	12 A (at $I_N = 10$ A)
Maximum temperature coefficient	< 0.1 %/K
Function	Overcurrent, undercurrent, window, error memory
Min. setting range	5 % ... 95 % (from $I_N$ )
Max. setting range	10 % ... 100 % (from $I_N$ )
Setting range for response delay	0.1 s ... 10 s
Setting range for starting delay	0 s ... 10 s
Basic accuracy	± 5 % (of scale end value)
Setting accuracy	≤ 5 % (of scale end value)
Repeat accuracy	≤ 2 %
Recovery time	500 ms

### Contact side

Contact type	2 floating PDT contacts
Maximum switching voltage	250 V AC (in acc. with IEC 60664-1)
Interrupting rating (ohmic load) max.	750 VA (3 A/250 V AC, module aligned, ≤ 5 mm spacing)
	1250 VA (5 A/250 V AC, module not aligned, ≥ 5 mm spacing)

# Monitoring relay - EMD-FL-C-10 - 2866022

## Technical data

### Contact side

Output fuse	5 A (fast-blow)
-------------	-----------------

### Power supply

Supply voltage range	24 V AC ... 240 V AC -15 % ... +10 %
	24 V DC ... 240 V DC -20 % ... +25 %

### General

Mechanical service life	approx. $2 \times 10^7$ cycles
Operating mode	100% operating factor
Mounting position	any
Assembly instructions	on standard DIN rail NS 35 in accordance with EN 60715
Electromagnetic compatibility	Conformance with EMC Directive 2004/108/EC
Housing insulation material	Polyamide PA, self-extinguishing
Color	green

### Connection data

Connection method	Screw connection
Stripping length	8 mm
Conductor cross section solid	0.5 mm <sup>2</sup> ... 2.5 mm <sup>2</sup>
Conductor cross section flexible	0.25 mm <sup>2</sup> ... 2.5 mm <sup>2</sup>
Conductor cross section AWG	20 ... 14
Tightening torque	1 Nm

### Standards and Regulations

Electromagnetic compatibility	Conformance with EMC Directive 2004/108/EC
Noise emission	EN 61000-6-4
Noise immunity	EN 61000-6-2
Standards/regulations	EN 50178
Rated insulation voltage	300 V
Insulation	Basic insulation
Pollution degree	2
Overvoltage category	III
Low Voltage Directive	Conformance with LV directive 2006/95/EC

### Environmental Product Compliance

China RoHS	Environmentally friendly use period: unlimited = EFUP-e
	No hazardous substances above threshold values

## Drawings

# Monitoring relay - EMD-FL-C-10 - 2866022

Block diagram

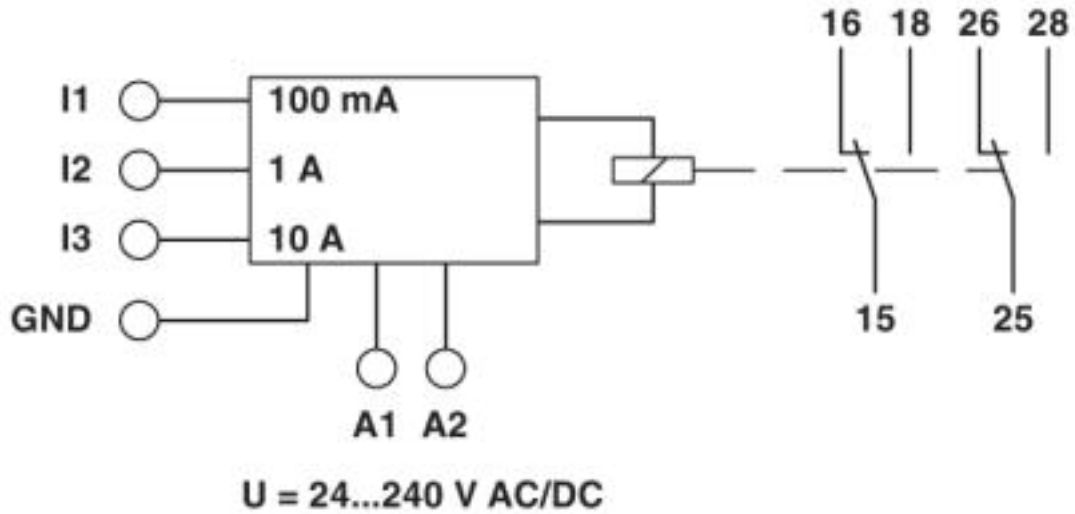

## Classifications

### eCl@ss

eCl@ss 4.0	27371100
eCl@ss 4.1	27371100
eCl@ss 5.0	27371800
eCl@ss 5.1	27371800
eCl@ss 6.0	27371800
eCl@ss 7.0	27371802
eCl@ss 8.0	27371802
eCl@ss 9.0	27371802

### ETIM

ETIM 2.0	EC001440
ETIM 3.0	EC001440
ETIM 4.0	EC001440
ETIM 5.0	EC001440
ETIM 6.0	EC001440
ETIM 7.0	EC001440

### UNSPSC

UNSPSC 6.01	30211916
UNSPSC 7.0901	39121535
UNSPSC 11	39121535
UNSPSC 12.01	39121535

# Monitoring relay - EMD-FL-C-10 - 2866022

## Classifications

### UNSPSC

UNSPSC 13.2	41113637
-------------	----------

## Approvals

### Approvals

#### Approvals

UL Listed / cUL Listed / EAC / EAC / cULus Listed

#### Ex Approvals

## Approval details

UL Listed		<a href="http://database.ul.com/cgi-bin/XYV/template/LISEXT/1FRAME/index.htm">http://database.ul.com/cgi-bin/XYV/template/LISEXT/1FRAME/index.htm</a>	FILE E 172140
-----------	--	---	---------------

cUL Listed		<a href="http://database.ul.com/cgi-bin/XYV/template/LISEXT/1FRAME/index.htm">http://database.ul.com/cgi-bin/XYV/template/LISEXT/1FRAME/index.htm</a>	FILE E 172140
------------	--	---	---------------

EAC			TR_TS_D_00573_c
-----	--	--	-----------------

EAC			TR_TS_S_00010_c
-----	--	--	-----------------

cULus Listed			
--------------	--	--	--