

Electronic housing - P 1-UEG - 2790224

Please be informed that the data shown in this PDF Document is generated from our Online Catalog. Please find the complete data in the user's documentation. Our General Terms of Use for Downloads are valid (<http://phoenixcontact.com/download>)

PCB for custom fitting electronic components



Key Commercial Data

Packing unit	1 pc
Minimum order quantity	10 pc
GTIN	 4 017918 072308
Weight per Piece (excluding packing)	7.28 g
Custom tariff number	85340019
Country of origin	Germany

Technical data

Product type	PCB
Approval	UL Recognized

Classifications

eCl@ss

eCl@ss 4.0	27180401
eCl@ss 4.1	27180401
eCl@ss 5.0	27180506
eCl@ss 5.1	27180506
eCl@ss 6.0	27180802
eCl@ss 7.0	27182702
eCl@ss 8.0	27182702

Electronic housing - P 1-UEG - 2790224

Classifications

eCl@ss

eCl@ss 9.0	27182702
------------	----------

ETIM

ETIM 2.0	EC001031
ETIM 3.0	EC001031
ETIM 4.0	EC001031
ETIM 5.0	EC001031

UNSPSC

UNSPSC 6.01	31261501
UNSPSC 7.0901	31261501
UNSPSC 11	31261501
UNSPSC 12.01	31261501
UNSPSC 13.2	31261501

Approvals

Approvals

Approvals

UL Recognized

Ex Approvals

Approvals submitted

Approval details

UL Recognized 

Drawings

Electronic housing - P 1-UEG - 2790224

Dimensional drawing

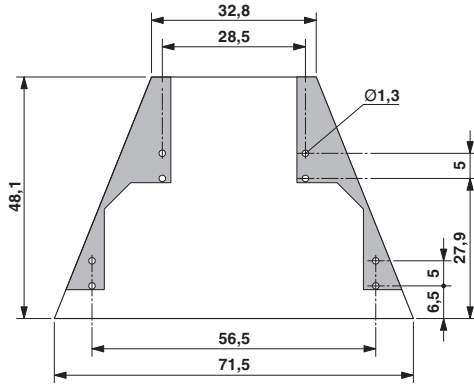

Schematic diagram

