

Electronic housing - EG 45-A/PC GN - 2764878

Please be informed that the data shown in this PDF Document is generated from our Online Catalog. Please find the complete data in the user's documentation. Our General Terms of Use for Downloads are valid (<http://phoenixcontact.com/download>)

Housing cover, for connection on both sides



Illustration shows a fully mounted version of the electronic housing

Product Features

- Tool-free mounting
- Date of manufacture and material and part identification embossed on the housing (recyclability)
- Fast snap-on mounting on symmetrical DIN rails according to EN 60715
- Practical and easy-to-wire conductor connection using extra finely stranded sturdy screw terminal blocks up to 2.5 mm²
- Optimum accommodation of electronic components with graded pitches with a design width of 22.5 mm, 45 mm, 67.5 mm, and 90 mm
- Functional and industry-oriented housing technology
- Shock and contamination-proof accommodation of electronic components (IP40 housing, IP20 terminal blocks)



Key Commercial Data

Packing unit	1 pc
Minimum order quantity	10 pc
GTIN	 4 017918 119676
Weight per Piece (excluding packing)	13.01 g
Custom tariff number	85389099
Country of origin	Germany

Technical data

General

Housing type	Component housing
Color	green

Electronic housing - EG 45-A/PC GN - 2764878

Technical data

Ambient conditions

Ambient temperature (operation)	80 °C
---------------------------------	-------

Dimensions

Length	75 mm
Constructional height	17.5 mm
Width	45 mm

Technical data

Number of positions	16
---------------------	----

Classifications

eCl@ss

eCl@ss 4.0	27180401
eCl@ss 4.1	27180401
eCl@ss 5.0	27180506
eCl@ss 5.1	27180506
eCl@ss 6.0	27180802
eCl@ss 7.0	27182702
eCl@ss 8.0	27182702
eCl@ss 9.0	27182702

ETIM

ETIM 2.0	EC001031
ETIM 3.0	EC001031
ETIM 4.0	EC001031
ETIM 5.0	EC001031

UNSPSC

UNSPSC 6.01	31261501
UNSPSC 7.0901	31261501
UNSPSC 11	31261501
UNSPSC 12.01	31261501
UNSPSC 13.2	31261501

Approvals

Approvals

Electronic housing - EG 45-A/PC GN - 2764878

Approvals

Approvals

UL Recognized

Ex Approvals

Approvals submitted

Approval details



Drawings

Dimensional drawing

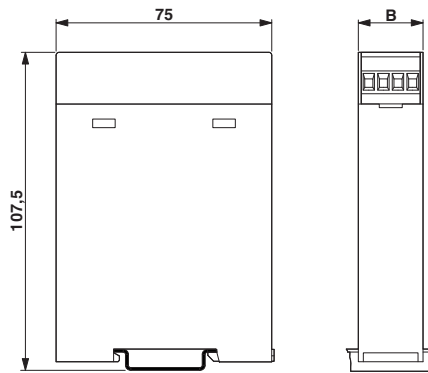

Electronic housing - EG 45-A/PC GN - 2764878

Explosion drawing

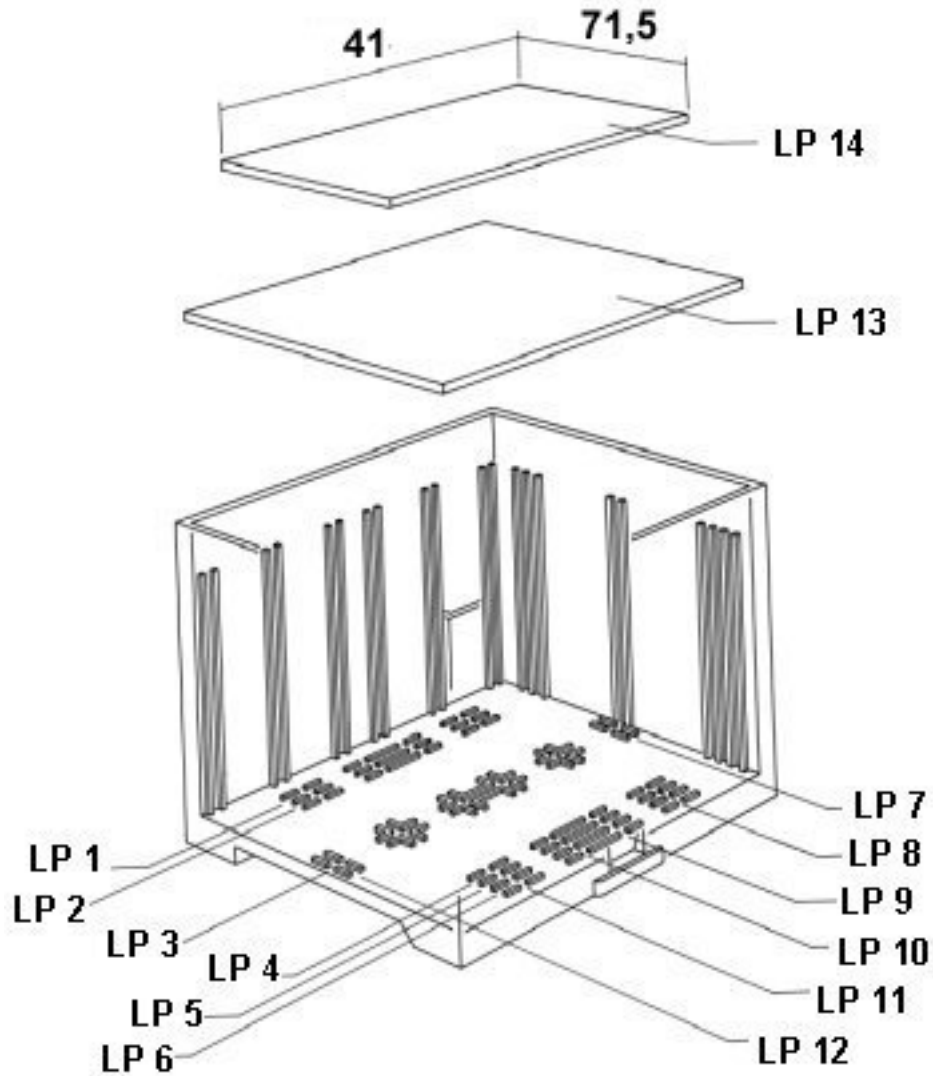

valid for PCB 13

Electronic housing - EG 45-A/PC GN - 2764878

Explosion drawing

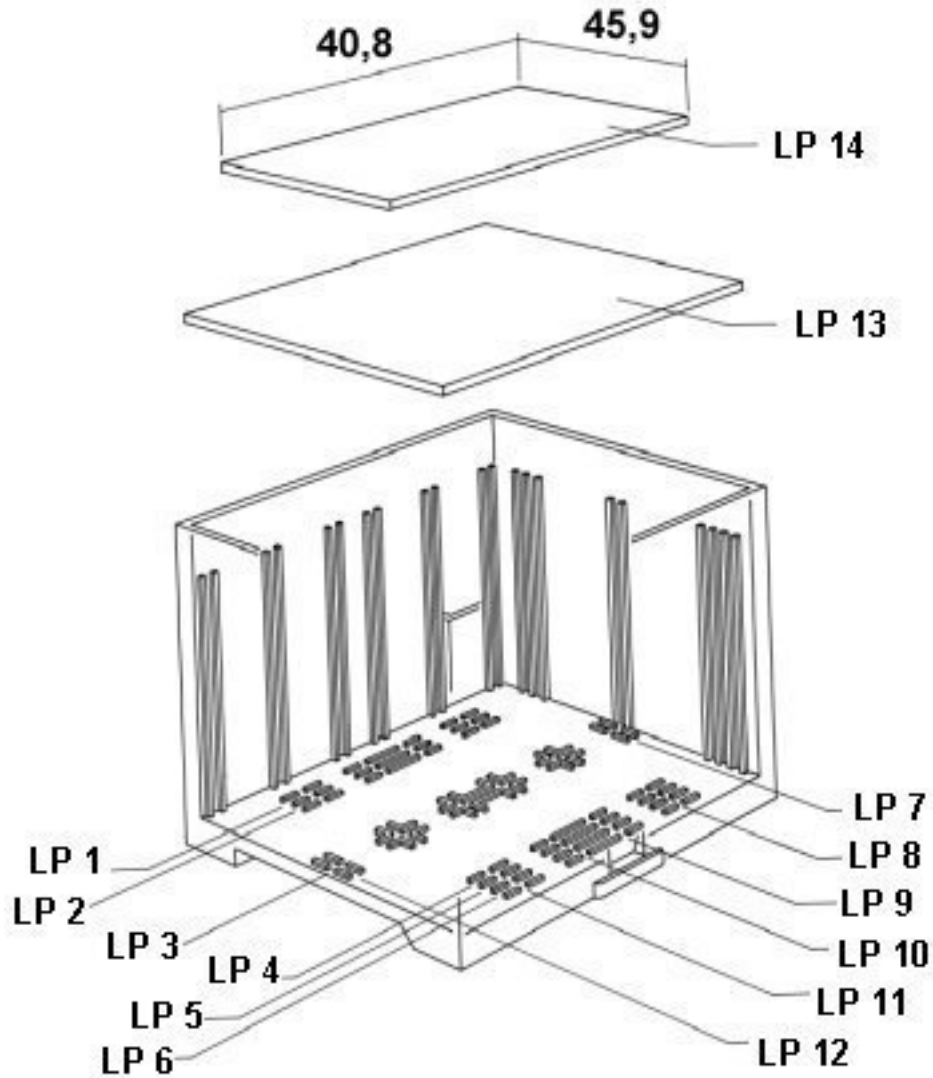

valid for PCB 14

Electronic housing - EG 45-A/PC GN - 2764878

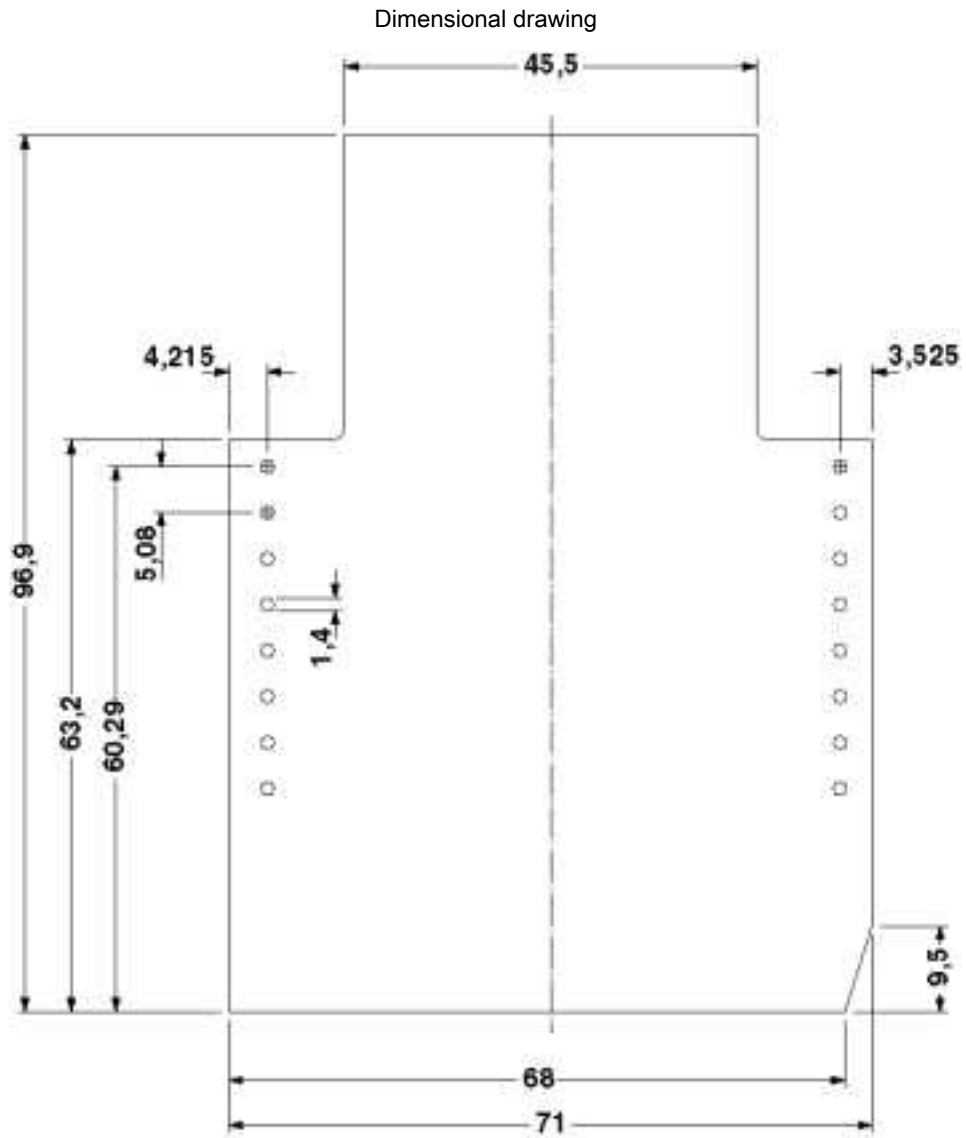

Component mounting side, if the double-level upper part is used

Electronic housing - EG 45-A/PC GN - 2764878

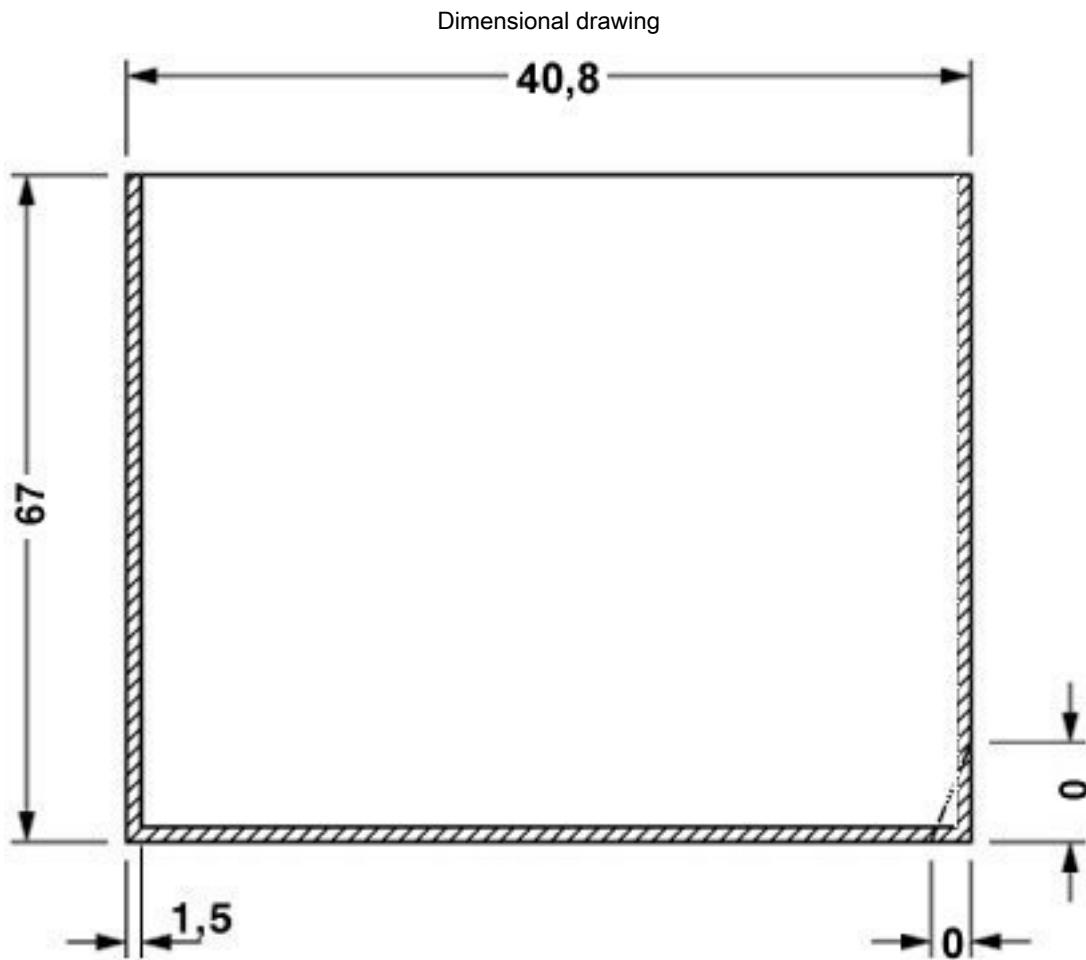

valid for PCB 1; 3; 5 and 6, see explosion drawing

Electronic housing - EG 45-A/PC GN - 2764878

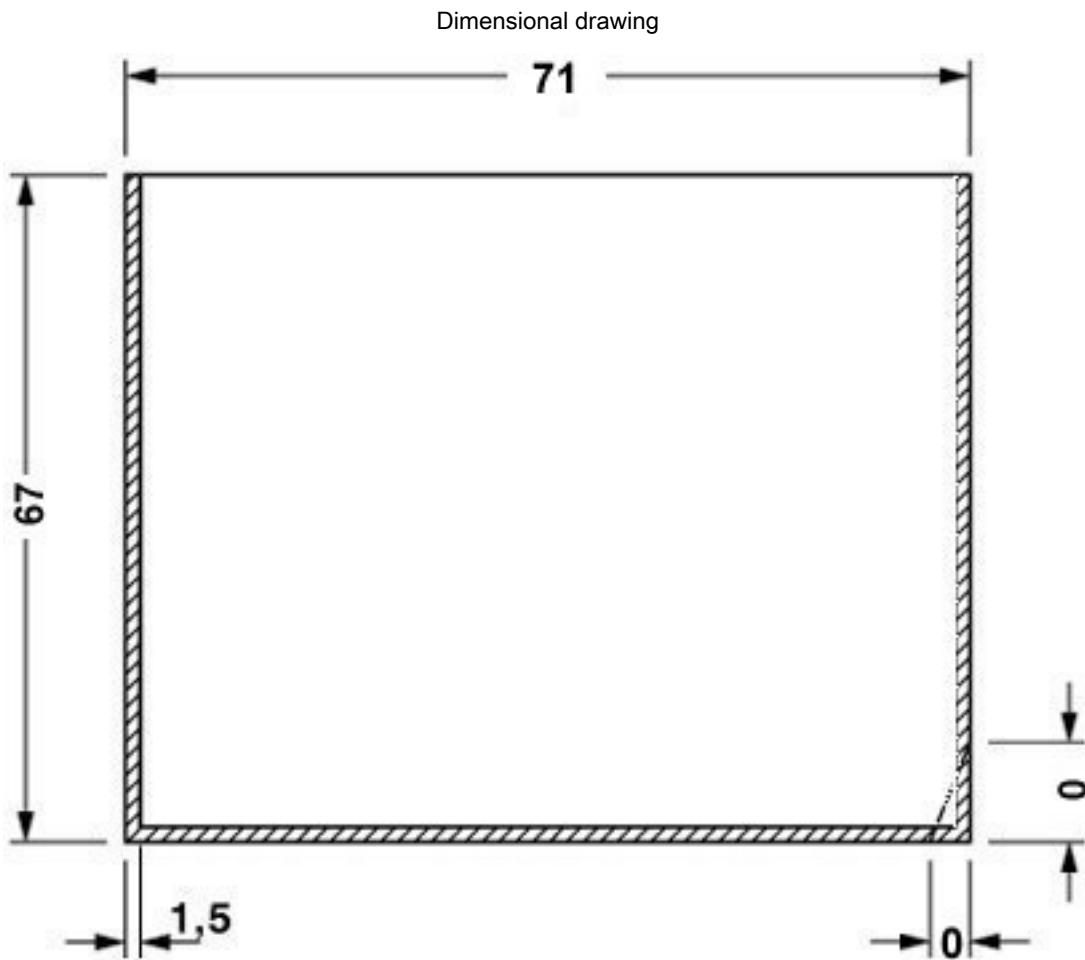

valid for PCB 7 and 12, see explosion drawing

Electronic housing - EG 45-A/PC GN - 2764878

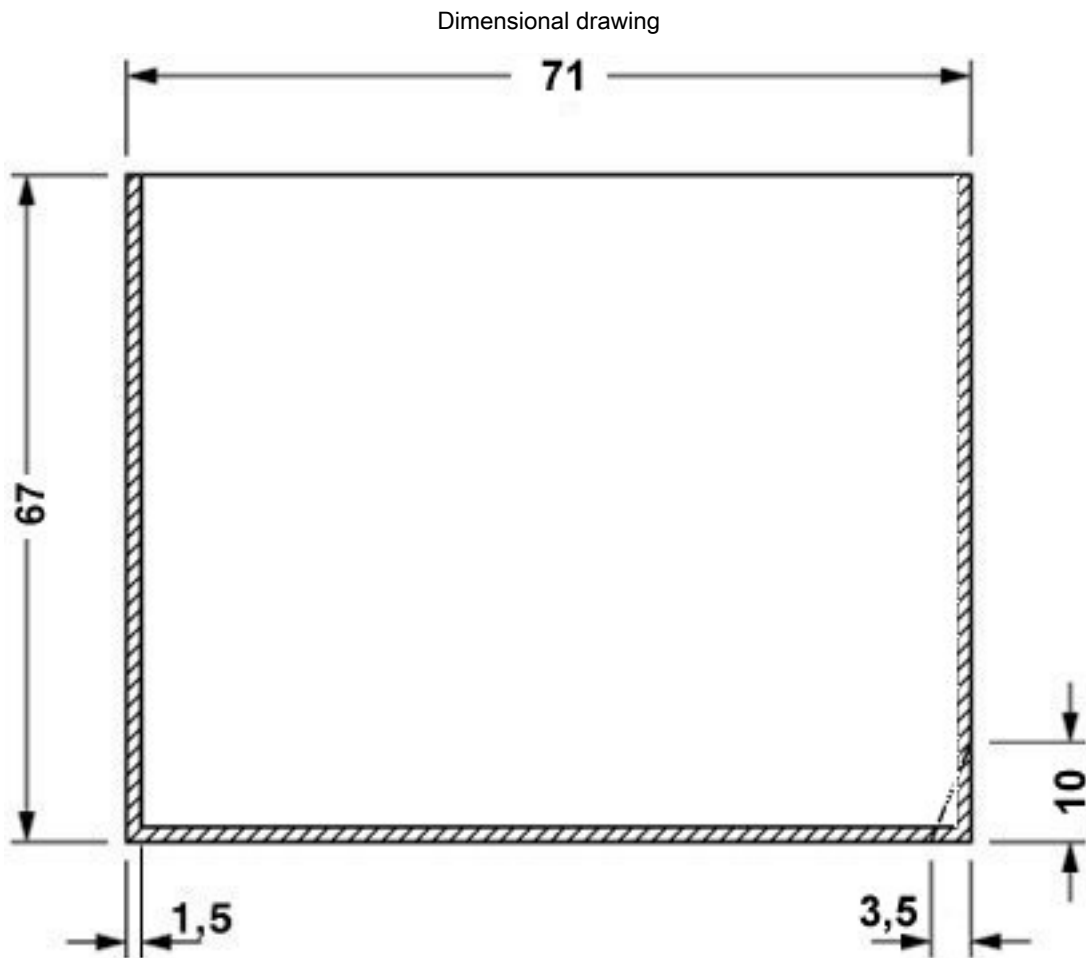

valid for PCB 10, see explosion drawing