

Antenna - RAD-ISM-2400-ANT-VAN-3-0-RSMA - 2701358

Please be informed that the data shown in this PDF Document is generated from our Online Catalog. Please find the complete data in the user's documentation. Our General Terms of Use for Downloads are valid (<http://phoenixcontact.com/download>)



Omnidirectional antenna with protection against vandalism, 2.4 GHz, gain: 3 dBi, polarization: linear, opening angle: h/v 360°/85°, degree of protection: IP55, connection: RSMA (male), for control cabinet mounting (optional wall mounting), incl. 1.5 m / 5 ft. connecting cable

Your advantages

- ✓ Impact-resistant housing
- ✓ For freely mobile applications
- ✓ For multipoint or mesh connections

Key Commercial Data

Packing unit	1 pc
GTIN	 4 046356 741750
GTIN	4046356741750
Weight per Piece (excluding packing)	180.000 g
Custom tariff number	85177000
Country of origin	Poland

Technical data

Dimensions

Width	86 mm
Height	43 mm
Fixed cable length	1.50 m

Ambient conditions

Degree of protection	IP55
Ambient temperature (operation)	-40 °C ... 80 °C

Antenna - RAD-ISM-2400-ANT-VAN-3-0-RSMA - 2701358

Technical data

Ambient conditions

Ambient temperature (storage/transport)	-40 °C ... 80 °C
---	------------------

General

With connecting cable	yes
Frequency range	2.4 GHz
	2.4 GHz
Horizontal beamwidth	360 °
Vertical beamwidth	85 °
Polarization	Linear vertical
Impedance	50 Ω
Gain	3 dBi
Wind velocity	160 km/h (Has a force of 10 N)
Connection method	RSMA (male)
Fixed cable length	1.50 m
Smallest bending radius, fixed installation	5 mm
Cable, attenuation	2 dB
Material	ASA (Antenna housing)
Mounting type	Control cabinet
Assembly instructions	Optional wall mounting

Environmental Product Compliance

	Lead 7439-92-1
China RoHS	Environmentally Friendly Use Period = 25;
	For details about hazardous substances go to tab "Downloads", Category "Manufacturer's declaration"

Drawings

Antenna - RAD-ISM-2400-ANT-VAN-3-0-RSMA - 2701358

Schematic diagram

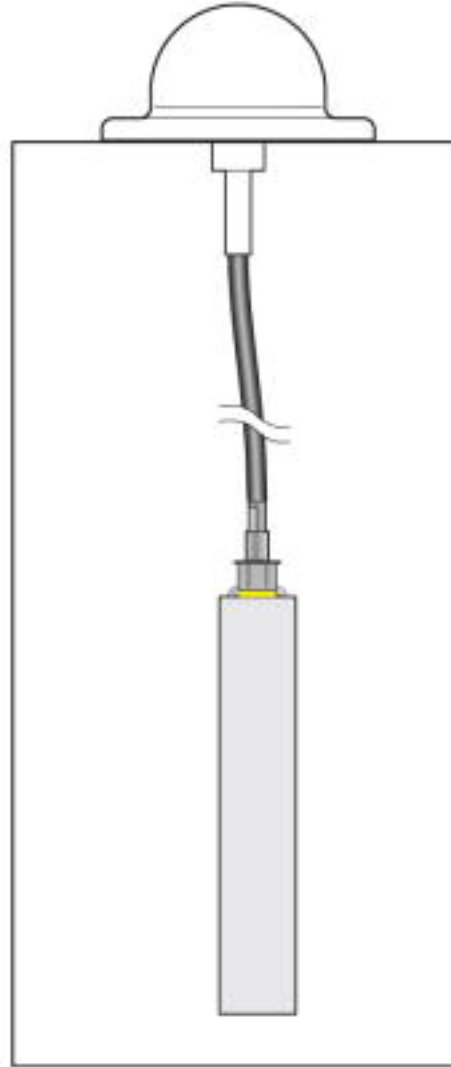

Installation example

Antenna - RAD-ISM-2400-ANT-VAN-3-0-RSMA - 2701358

Drilling diagram

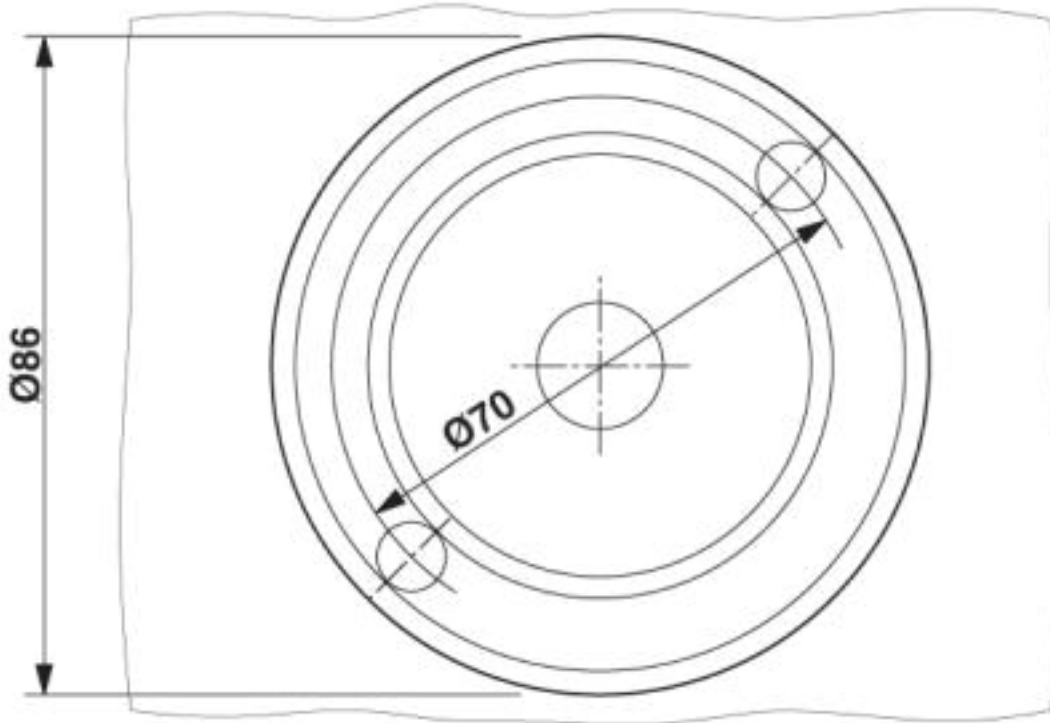

Dimensional drawing

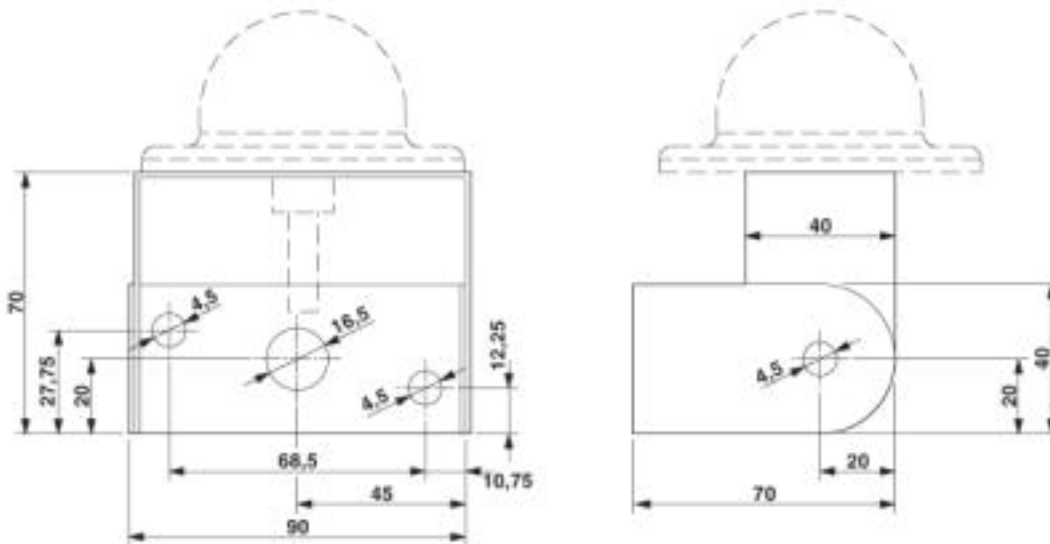

Antenna - RAD-ISM-2400-ANT-VAN-3-0-RSMA - 2701358

Classifications

eCl@ss

eCl@ss 4.0	27250300
eCl@ss 4.1	27250300
eCl@ss 5.0	19070100
eCl@ss 5.1	19070100
eCl@ss 6.0	19070100
eCl@ss 7.0	19070105
eCl@ss 8.0	19070105
eCl@ss 9.0	19070105

ETIM

ETIM 2.0	EC000416
ETIM 3.0	EC001698
ETIM 4.0	EC001698
ETIM 5.0	EC001698
ETIM 6.0	EC001698
ETIM 7.0	EC001698

UNSPSC

UNSPSC 6.01	43171611
UNSPSC 7.0901	43221706
UNSPSC 11	43171611
UNSPSC 12.01	43221706
UNSPSC 13.2	43221715

Accessories

Accessories

Mounting material

Mounting material - RAD-ANT-VAN-MKT - 2885870



Mounting material for wall mounting of omnidirectional antenna with protection against vandals