

PCB terminal block - FKDSO 2,5/ 3-L KMGY - 2200318

Please be informed that the data shown in this PDF Document is generated from our Online Catalog. Please find the complete data in the user's documentation. Our General Terms of Use for Downloads are valid (<http://phoenixcontact.com/download>)



PCB terminal block, nominal current: 22 A, pitch: 5 mm, number of positions: 3, connection method: Push-in spring connection, mounting: Wave soldering, conductor/PCB connection direction: 0 °, color: light gray. Article with lateral pin exit

Your advantages

- Spring-cage PCB terminal block for ME/ME MAX electronics housing
- Push-in Technology simplifies connection
- 5 mm pitch

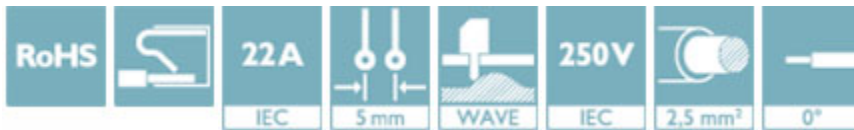

Key Commercial Data

Packing unit	1 pc
Minimum order quantity	50 pc
GTIN	 4 046356 563833
GTIN	4046356563833
Weight per Piece (excluding packing)	4.000 g
Custom tariff number	85369010
Country of origin	Poland

Technical data

Item properties

Pitch	5 mm
Number of positions	3
Connection method	Push-in spring connection
Mounting type	Wave soldering
Pin layout	Linear pinning

PCB terminal block - FKDSO 2,5/ 3-L KMGY - 2200318

Technical data

Electrical parameters

Rated current	22 A
Rated voltage (III/2)	250 V
Rated surge voltage (III/2)	4 kV

Connection capacity

Conductor cross section solid	0.2 mm ² ... 2.5 mm ²
Conductor cross section flexible	0.2 mm ² ... 2.5 mm ²
Conductor cross section AWG / kcmil	24 ... 14
Conductor cross section flexible, with ferrule without plastic sleeve	0.25 mm ² ... 2.5 mm ²
Conductor cross section, flexible, with ferrule, with plastic sleeve	0.25 mm ² ... 2.5 mm ²
2 conductors with same cross section, stranded, with TWIN ferrules with plastic sleeve	0.5 mm ² ... 1.5 mm ²
Stripping length	10 mm

Material data - contact

Note	WEEE/RoHS-compliant, free of whiskers according to IEC 60068-2-82/ JEDEC JESD 201
Contact material	Cu alloy
Surface characteristics	Tin-plated
Metal surface terminal point (top layer)	Tin (5 - 7 µm Sn)
Metal surface soldering area (top layer)	Tin (5 - 7 µm Sn)

Material data - housing

Insulating material	PA
Insulating material group	I
CTI according to IEC 60112	600
Flammability rating according to UL 94	V0

Dimensions for the product

Length [l]	25.9 mm
Height [h]	26.5 mm
Pitch	5 mm
Height (without solder pin)	24 mm
Solder pin [P]	3.5 mm
Pin spacing	5.08 mm
Pin dimensions	0.8 x 1 mm
Dimension a	10 mm

Dimensions for PCB design

Hole diameter	1.4 mm
Pin spacing	5.08 mm

PCB terminal block - FKDSO 2,5/ 3-L KMGY - 2200318

Technical data

Packaging information

Pieces per package	50
Denomination packing units	Pcs.

Processing notes

Process	Wave soldering
Specification	Following IEC 61760-1:2006-04
	Following IEC 60068-2-54:2006-04

Ambient conditions

Ambient temperature (storage/transport)	-40 °C ... 70 °C
Ambient temperature (assembly)	-5 °C ... 100 °C
Ambient temperature (operation)	-40 °C (Depending on the current carrying capacity/derating curve)

Termination and connection method

Test for conductor damage and slackening	IEC 60999-1:1999-11
	Test passed

Pull-out test

Pull-out test	IEC 60999-1:1999-11
	Test passed
Conductor cross section / conductor type / tensile force	0.2 mm ² / solid / > 10 N
	2.5 mm ² / solid / > 50 N
	0.2 mm ² / flexible / > 10 N
	4 mm ² / flexible / > 60 N

Mechanical tests according to standard

Test specification	IEC 60947-7-4
--------------------	---------------

Electrical tests

Rated current	22 A
Conductor cross section	2.5 mm ²
Rated voltage (III/2)	250 V
Rated surge voltage (III/2)	4 kV

Air clearances and creepage distances

Specification	IEC 60947-1:2007-06 + A1:2010-12
Rated insulation voltage (III/3)	250 V
Rated insulation voltage (III/2)	250 V
Rated insulation voltage (II/2)	630 V
Rated surge voltage (III/3)	4 kV
Rated surge voltage (III/2)	4 kV

PCB terminal block - FKDSO 2,5/ 3-L KMGY - 2200318

Technical data

Air clearances and creepage distances

Rated surge voltage (II/2)	4 kV
Minimum clearance - inhomogeneous field (III/3)	3 mm
Minimum clearance - inhomogeneous field (III/2)	3 mm
Minimum clearance - inhomogeneous field (II/2)	3 mm
Minimum creepage distance value (III/3)	3.2 mm
Minimum creepage distance value (III/2)	1.25 mm
Minimum creepage distance value (II/2)	3.2 mm

Current carrying capacity / derating curves

Specification	IEC 60947-7-4
---------------	---------------

Environmental Product Compliance

China RoHS	Environmentally friendly use period: unlimited = EFUP-e
	No hazardous substances above threshold values

Drawings

PCB terminal block - FKDSO 2,5/ 3-L KMGY - 2200318

Drilling diagram

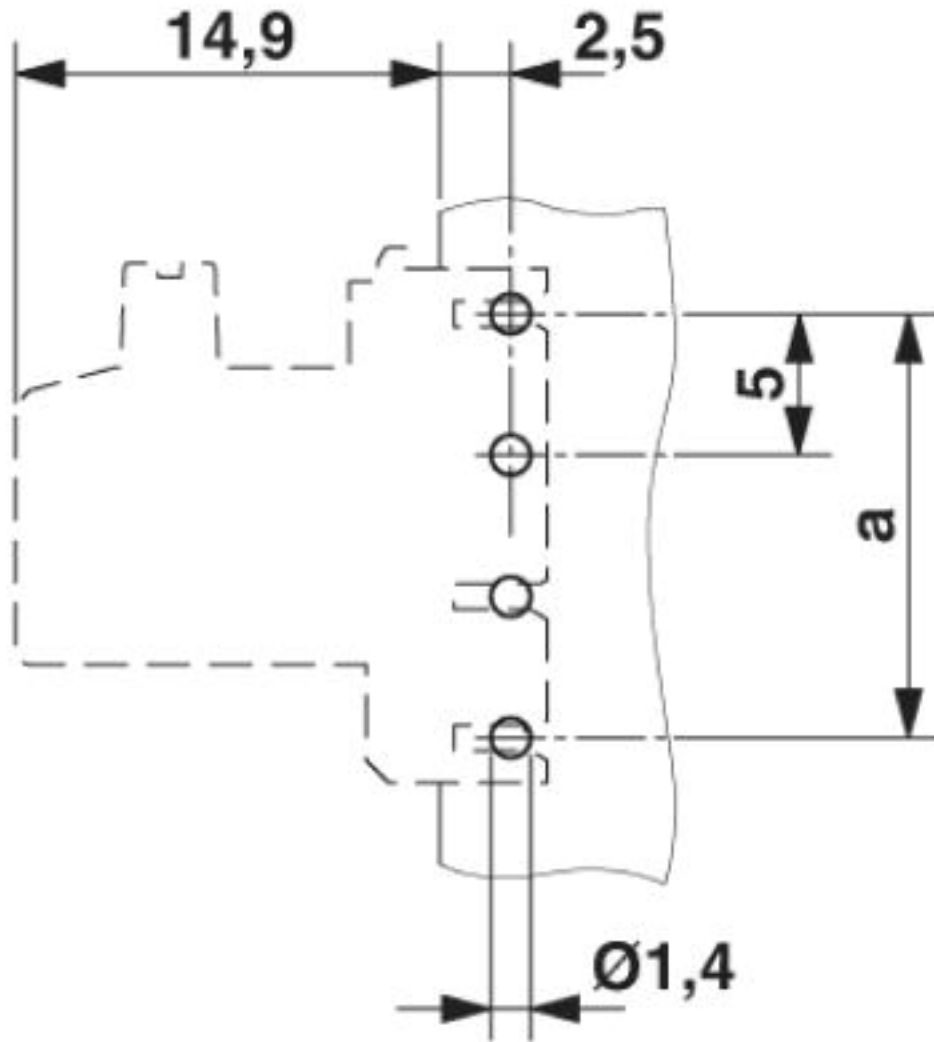

PCB terminal block - FKDSO 2,5/ 3-L KMGY - 2200318

Diagram

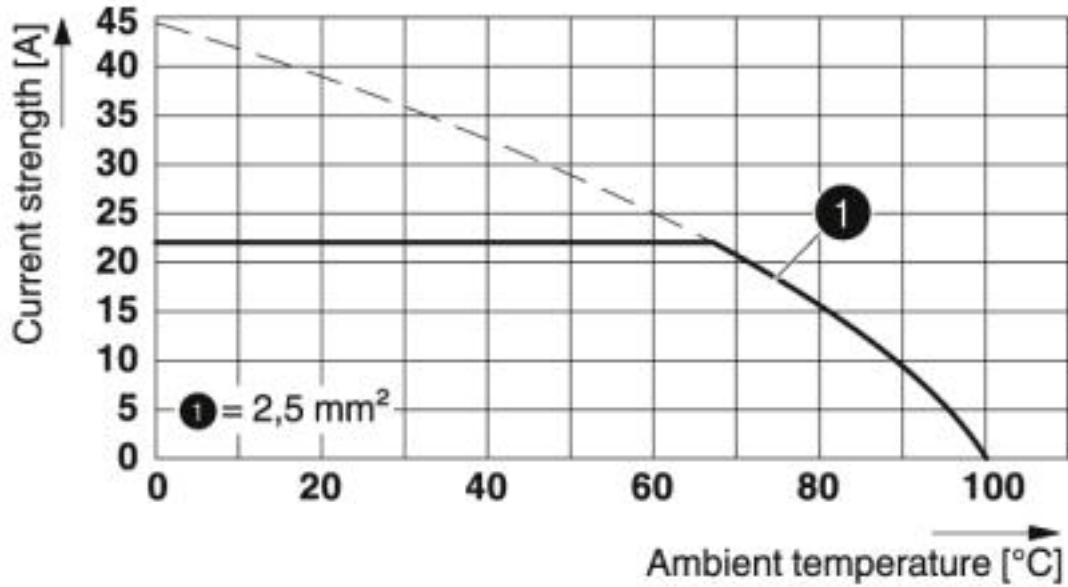

Type: FKDSO 2,5/...-L(R)
 Tested according to DIN EN 60512-5-2:2003-01
 Reduction factor = 1
 Number of positions: 4

Classifications

eCl@ss

eCl@ss 4.0	27180400
eCl@ss 4.1	27180400
eCl@ss 5.0	27180500
eCl@ss 5.1	27261100
eCl@ss 6.0	27261100
eCl@ss 7.0	27440401
eCl@ss 8.0	27440401
eCl@ss 9.0	27440401

ETIM

ETIM 2.0	EC001031
ETIM 3.0	EC001031
ETIM 4.0	EC002643
ETIM 5.0	EC002643
ETIM 6.0	EC002643
ETIM 7.0	EC002643

PCB terminal block - FKDSO 2,5/ 3-L KMGY - 2200318

Classifications

UNSPSC

UNSPSC 6.01	31261501
UNSPSC 7.0901	31261501
UNSPSC 11	31261501
UNSPSC 12.01	31261501
UNSPSC 13.2	39121432

Approvals

Approvals

Approvals

IECEE CB Scheme / VDE Gutachten mit Fertigungsüberwachung / EAC / cULus Recognized

Ex Approvals

Approval details

IECEE CB Scheme		http://www.iecee.org/	DE1-59403
Nominal voltage UN	250 V		
Nominal current IN	22 A		
mm ² /AWG/kcmil	0.2-2.5		

VDE Gutachten mit Fertigungsüberwachung		http://www2.vde.com/de/Institut/Online-Service/VDE-gepruefteProdukte/Seiten/Online-Suche.aspx	40033478
Nominal voltage UN	250 V		
Nominal current IN	22 A		
mm ² /AWG/kcmil	0.2-2.5		

EAC		B.01742
-----	---	---------

PCB terminal block - FKDSO 2,5/ 3-L KMGY - 2200318

Approvals

cULus Recognized		http://database.ul.com/cgi-bin/XYV/template/LISEXT/1FRAME/index.htm	E60425-20110930
	B	D	
Nominal voltage UN	300 V	300 V	
Nominal current IN	10 A	5 A	
mm ² /AWG/kcmil	24-14	24-14	