

Cable gland - HC-K-KV-M20(8-13) - 1690626

Please be informed that the data shown in this PDF Document is generated from our Online Catalog. Please find the complete data in the user's documentation. Our General Terms of Use for Downloads are valid (<http://phoenixcontact.com/download>)



Plastic screw connection up to 5 bar, thread length: 8 mm, cable diameter: 8 - 13 mm, WAF 24, screw connection: M20



Key Commercial Data

Packing unit	1 pc
Minimum order quantity	25 pc
Weight per Piece (excluding packing)	8.784 g
Custom tariff number	39269097
Country of origin	Germany

Technical data

Dimensions

Wrench size, union nut	24 mm
Wrench size, support	24 mm
Length of the connecting thread	8 mm
External cable diameter	8 mm ... 13 mm

Ambient conditions

Degree of protection	IP68, to 5 bar
	IP68 (Up to 5 bar)
Ambient temperature (operation)	-20 °C ... 100 °C

General

Type of the screw connection	M20
No. of conductors	1
Cable gland material	Polyamide
Seal material	Neoprene
Cable seal material	Neoprene

Cable gland - HC-K-KV-M20(8-13) - 1690626

Technical data

General

Shielded	No
Thread type on connection side	M20
Tightening torque, union nut	2.70 Nm
Flammability rating according to UL 94	V2
Color	silver gray

Standards and Regulations

Flammability rating according to UL 94	V2
--	----

Classifications

eCl@ss

eCl@ss 4.0	27141209
eCl@ss 4.1	27141209
eCl@ss 5.0	27149109
eCl@ss 5.1	27149109
eCl@ss 6.0	27149109
eCl@ss 7.0	27149109
eCl@ss 8.0	27149109

ETIM

ETIM 2.0	EC000441
ETIM 3.0	EC000441
ETIM 4.0	EC000441
ETIM 5.0	EC000441

UNSPSC

UNSPSC 6.01	31261502
UNSPSC 7.0901	31261502
UNSPSC 11	31261502
UNSPSC 12.01	31261502
UNSPSC 13.2	31261502

Approvals

Approvals

Cable gland - HC-K-KV-M20(8-13) - 1690626

Approvals

Approvals

EAC

Ex Approvals

Approvals submitted

Approval details

EAC

Drawings

Dimensional drawing

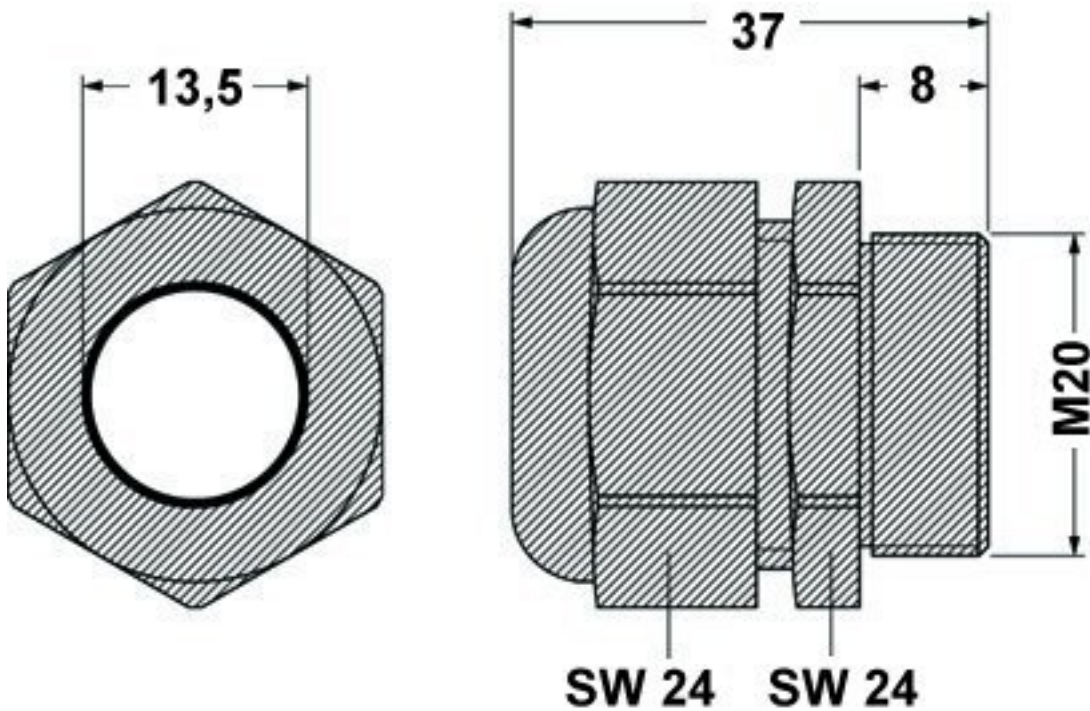

Dimensional drawing

