

# AC axial compact fan

sickled blades (S series), single inlet

## ebm-papst Mulfingen GmbH & Co. KG

Bachmühle 2 · D-74673 Mulfingen

Phone +49 7938 81-0

Fax +49 7938 81-110

info1@de.ebmpapst.com

www.ebmpapst.com

Limited partnership · Headquarters Mulfingen

County court Stuttgart · HRA 590344

General partner Elektrobau Mulfingen GmbH · Headquarters Mulfingen

County court Stuttgart · HRB 590142

## Nominal data

Type	W2S130-AB25-24		
Motor	M2S052-CA		
Phase		1~	1~
Nominal voltage	VAC	115	115
Frequency	Hz	50	60
Type of data definition		fa	fa
Valid for approval / standard		CE	CE
Speed	min <sup>-1</sup>	2800	3220
Power input	W	40	39
Current draw	A	0.56	0.46
Min. ambient temperature	°C	-25	-25
Max. ambient temperature	°C	50	70
Starting current	A	0.86	0.73

ml = Max. load · me = Max. efficiency · fa = Running at free air · cs = Customer specs · cu = Customer unit  
Subject to alterations



### Technical features

<b>Mass</b>	1.1 kg
<b>Size</b>	130 mm
<b>Surface of rotor</b>	Coated in black
<b>Material of blades</b>	Sheet steel, coated in black
<b>Material of wall ring</b>	Die-cast aluminium, coated in black
<b>Number of blades</b>	7
<b>Direction of air flow</b>	"V"
<b>Direction of rotation</b>	Counter-clockwise, seen on rotor
<b>Type of protection</b>	IP 44; Depending on installation and position
<b>Insulation class</b>	"B"
<b>Max. permissible ambient motor temp. (transp./ storage)</b>	+ 80 °C
<b>Min. permissible ambient motor temp. (transp./storage)</b>	- 40 °C
<b>Mounting position</b>	Any
<b>Condensate discharge holes</b>	None
<b>Operation mode</b>	S1
<b>Motor bearing</b>	Ball bearing
<b>Touch current acc. IEC 60990 (measuring network Fig. 4, TN system)</b>	< 0.75 mA
<b>Motor protection</b>	Thermal overload protector (TOP) wired internally
<b>Protection class</b>	I (if protective earth is connected by customer)
<b>Product conforming to standard</b>	EN 60335-1; CE
<b>Approval</b>	UL 1004-1; CSA C22.2 Nr.100

## Product drawing

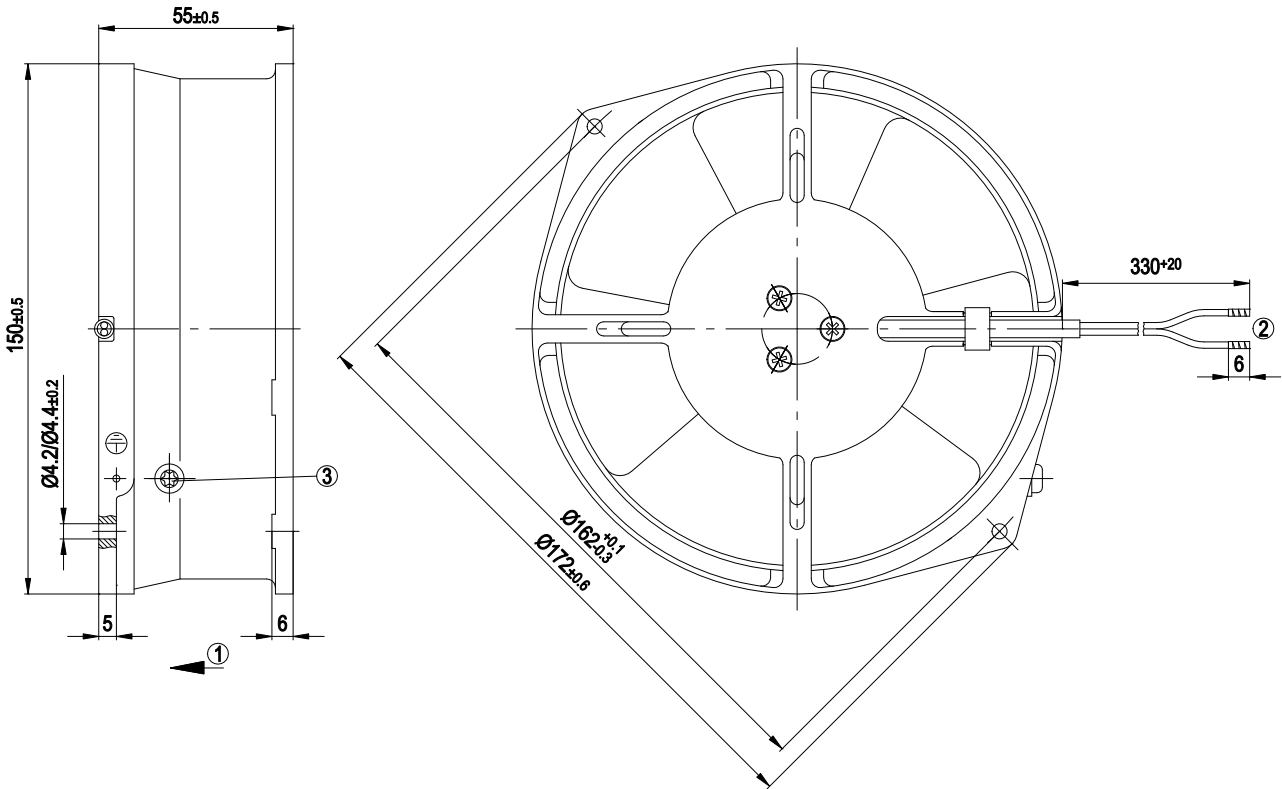

1	Direction of air flow "V"
2	Connection line AWG20, 2x lead tips crimped
3	M4 screw for fastening earth conductor

## Connection screen

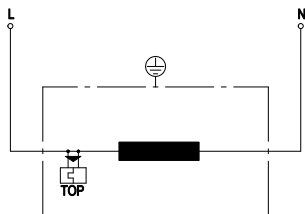

L	= black
N	= black
TOP	= Thermal overload protector

## Charts: Air flow 50 Hz

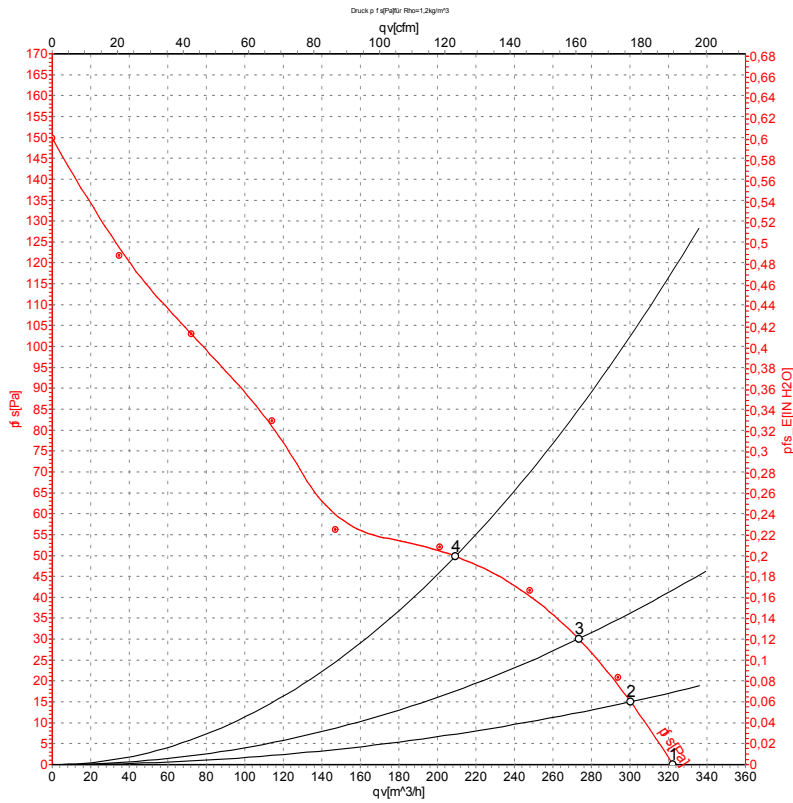

Measurement: LU-58320

Air performance measured as per ISO 5801 Installation category A. For detailed information on the measuring set-up, please contact ebm-papst. Suction-side noise levels: LwA measured as per ISO 13347 / LpA measured with 1m distance to fan axis. The values given are valid under the measuring conditions mentioned above and may vary according to the actual installation situation. With any deviation from the standard set-up, the specific values have to be checked and reviewed with the unit installed.

## Measured values

	U	f	n	P <sub>e</sub>	I	qv	P <sub>fs</sub>
	V	Hz	min <sup>-1</sup>	W	A	m <sup>3</sup> /h	Pa
1	115	50	2800	41	0.56	325	0
2	115	50	2800	42	0.56	300	15
3	115	50	2795	42	0.57	275	30
4	115	50	2790	43	0.57	210	50

U = Supply voltage · f = Frequency · n = Speed · P<sub>e</sub> = Power input · I = Current draw · qv = Air flow · P<sub>fs</sub> = Pressure increase



## Charts: Air flow 60 Hz

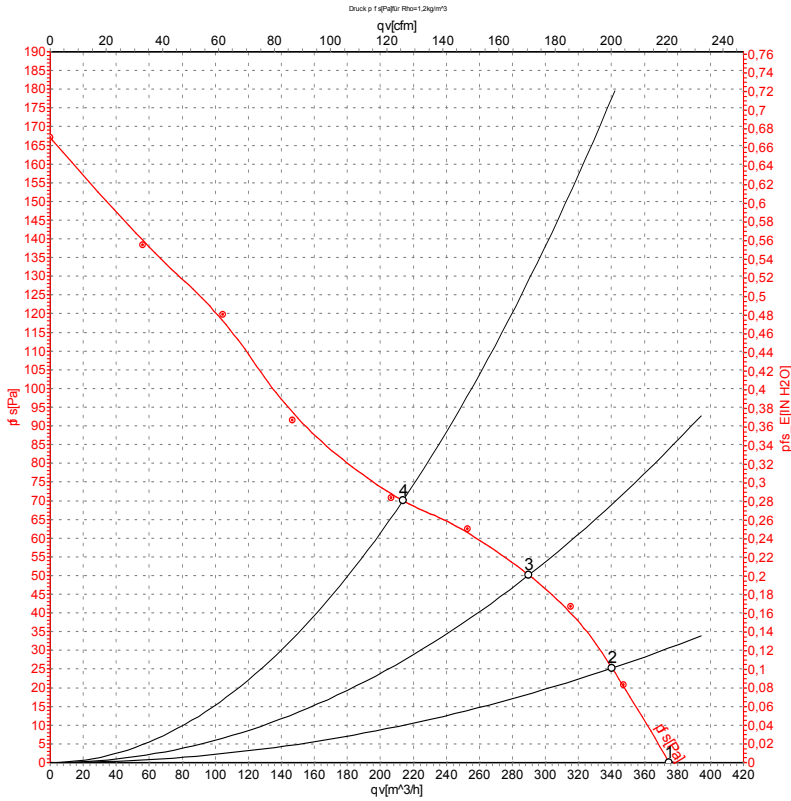

Measurement: LU-58323

Air performance measured as per ISO 5801 Installation category A. For detailed information on the measuring set-up, please contact ebm-papst. Suction-side noise levels: L<sub>wA</sub> measured as per ISO 13347 / L<sub>pA</sub> measured with 1m distance to fan axis. The values given are valid under the measuring conditions mentioned above and may vary according to the actual installation situation. With any deviation from the standard set-up, the specific values have to be checked and reviewed with the unit installed.

## Measured values

	U	f	n	P <sub>e</sub>	I	qv	p <sub>fs</sub>
	V	Hz	min <sup>-1</sup>	W	A	m³/h	Pa
1	115	60	3250	38	0.47	380	0
2	115	60	3210	40	0.48	340	25
3	115	60	3180	41	0.48	290	50
4	115	60	3180	41	0.48	215	70

U = Supply voltage · f = Frequency · n = Speed · P<sub>e</sub> = Power input · I = Current draw · qv = Air flow · p<sub>fs</sub> = Pressure increase

