

Rotary Encoder (Incremental/Absolute) E6C3

An Encoder That Offers Durability and Convenience

- IP65f drip-proof, oil-proof construction with sealed bearing.
- 8-mm-dia stainless steel shaft withstands a shaft loading of 80 N and 50 N respectively in the radial and thrust directions.
- Absolute Rotary Encoders have a metal slit plate to ensure high resistance to shock.
- Combining Absolute Rotary Encoders with a Programmable Controller or Cam Positioner allows ideal angle control.
- CE markings (EMC Directives) and conforms to EN/IEC standards.



Ordering Information

■ Incremental Rotary Encoders

Stock Note: Shaded items are normally stocked.

Supply voltage	Output configuration	Resolution (P/R)	Connection method	Model
12 to 24 VDC	Complementary output	100, 200	Pre-wired (1 m) (See note 2.)	E6C3-CWZ5GH
		300, 360, 500		
		600, 720, 800		
		1,000, 1,024, 1,200		
		1,500, 1,800, 2,000		
		2,048, 2,500, 3,600		
5 to 12 VDC	Voltage output	100, 200		E6C3-CWZ3EH
		300, 360, 500		
		600, 720, 800		
		1,000, 1,024, 1,200		
		1,500, 1,800, 2,000		
		2,048, 2,500, 3,600		
5 to 12 VDC	Line driver output	100, 200		E6C3-CWZ3XH
		300, 360, 500		
		600, 720, 800		
		1,000, 1,024, 1,200		
		1,500, 1,800, 2,000		
		2,048, 2,500, 3,600		

- Note:**
1. When ordering, specify the resolution in addition to the model numbers. (Example: E6C3-CWZ5GH 300P/R 1M)
 2. Models with 2-m cables are also available as standard products. Specify the cable length at the end of the model number. (Example: E6C3-CWZ5GH 300P/R 2M)

■ Absolute Rotary Encoders

Stock Note: Shaded items are normally stocked.

Supply voltage	Output configuration	Output code	Resolution (P/R)	Connection method	Model
12 to 24 VDC	NPN open collector output	Gray code	256, 360	Connector	E6C3-AG5C-C (See note 3)
			256, 360, 720, 1,024	Pre-wired (1 m) (See note 2.)	E6C3-AG5C
		Binary	32, 40		E6C3-AN5C
		BCD	6, 8, 12		E6C3-AB5C
	PNP open collector output	Gray code	256, 360, 720, 1,024	E6C3-AG5B	
		Binary	32, 40	E6C3-AN5B	
		BCD	6, 8, 12	E6C3-AB5B	
5 VDC	Voltage output	Binary	256	E6C3-AN1E	
12 VDC				E6C3-AN2E	

- Note:**
1. When ordering, specify the resolution in addition to the model numbers. (Example: E6C3-AG5C 360P/R 1M)
 2. Models with 2-m cables are also available as standard products. Specify the cable length at the end of the model number. (Example: E6C3-AG5C 360P/R 2M)
 3. When connecting to the H8PS, be sure to use the E6C3-AG5C-C 256P/R.

■ Accessories (Order Separately)

Stock Note: Shaded items are normally stocked.

Item	Remarks	Model	
Coupling	---	E69-C08B	
	Diameters of ends: 6 to 8 dia.	E69-C68B	
Flange	---	E69-FCA03	
	E69-2 Servo Mounting Bracket provided.	E69-FCA04	
Servo Mounting Bracket	Provided with the E69-FCA04 Flange.	E69-2	
Extension Cable	5 m	Applicable for the E6C3-AG5C-C. 15- and 98-m-long Extension Cables are also available.	
	10 m		E69-DF10
	30 m		E69-DF20

Specifications

■ Ratings/Characteristics

Incremental Rotary Encoders

Item	E6C3-CWZ5GH	E6C3-CWZ3EH	E6C3-CWZ3XH
Power supply voltage	12 VDC -10% to 24 VDC +15%	5 VDC -5% to 12 VDC +10%	
Current consumption (See note 1.)	100 mA max.		
Resolution (pulse/rotation)	100, 200, 300, 360, 500, 600, 720, 800, 1,000, 1,024, 1,200, 1,500, 1,800, 2,000, 2,048, 2,500, 3,600		
Output phases	A, B, and Z		A, \bar{A} , B, \bar{B} , Z, \bar{Z}
Output configuration	Complementary output (See note 5.)	Voltage output (NPN output)	Line driver output (See note 2.)
Output capacity	Output voltage: VH: Vcc - 3 V min. (Io: 30 mA) VL: 2 V max. (Io: -30 mA) Output current: \pm 30 mA	Output resistance: 2 k Ω Output current: 35 mA max. Residual voltage: 0.7 V max.	AM26LS31 equivalent Output current: High level (Io): -10 mA Low level (Is): 10 mA Output voltage: Vo: 2.5 V min. Vs: 0.5 V max.
Max. response frequency (See note 3.)	125 kHz (65 kHz for phase-Z reset)		
Phase difference on output	90° \pm 45° between A and B (1/4T \pm 1/8T)		
Rise and fall times of output	1 μ s max. (cable length: 2 m, output current: 30 mA)	1 μ s max. (cable length: 2 m, output current: 35 mA)	1 μ s max. (cable length: 2 m; Io: -10 mA; Is: 10 mA)
Starting torque	10 mN·m max. at room temperature; 30 mN·m max. at low temperature		
Moment of inertia	2.0 \times 10 ⁻⁶ kg·m ² ; 1.9 \times 10 ⁻⁶ kg·m ² at 500 P/R max.		
Shaft loading	Radial	80 N	
	Thrust	50 N	
Max. permissible revolution	5,000 rpm		
Protection circuits	Reversed power supply connection protection circuit, output load short-circuit protection circuit	---	
Ambient temperature	Operating: -10°C to 70°C (with no icing) Storage: -25°C to 85°C (with no icing)		
Ambient humidity	35% to 85% (with no condensation)		
Insulation resistance	20 M Ω min. (at 500 VDC) between current-carrying parts and case		
Dielectric strength	500 VAC, 50/60 Hz for 1 min between current-carrying parts and case		
Vibration resistance	10 to 500 Hz, 150 m/s ² or 2-mm double amplitude for 11 min 3 times each in X, Y, and Z directions		
Shock resistance	1,000 m/s ² 3 times each in X, Y, and Z directions		
Degree of protection	IEC60529 IP65 (JEM IP65f for drip-proof and oil-proof construction) (See note 4.)		
Connection method	Pre-wired (standard length: 1 m)		
Weight (packed state)	Approx. 300 g		
Others	Instruction manual		

Note: 1. An inrush current of approx. 9 A flows for approx. 0.1 ms right after the E6C3 is turned on.

2. The line driver output of the E6C3 is used for data transmission circuitry conforming to RS-422A and ensures long-distance transmission over twisted-pair cable, the quality of which is equivalent to AM26LS31.

3. The maximum electrical response revolution is determined by the resolution and maximum response frequency as follows:
Maximum electrical response frequency (rpm) = Maximum response frequency/resolution \times 60
This means that the E6C3 will not operate electrically if its revolution exceeds the maximum electrical response revolution.

4. JEM1030: applicable since 1991.

5. Complementary Output:

The complementary output has two output transistors (NPN and PNP) as shown below. These two output transistors alternately turn ON and OFF depending on the "H" or "L" output signal. When using them, pull up to the positive power or pull down to 0 V. The complementary output allows flow-in or flow-out of the output current and thus the rising and falling speeds of signals are fast. This allows a long cable distance. They can be connected to open-collector input devices (NPN, PNP).

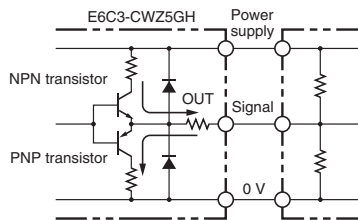

6. Phase-Z signals are output when the relationship between the shaft's D cut position and the cable's pullout direction is as shown in the following diagram. (Output position range: $\pm 15^\circ$).

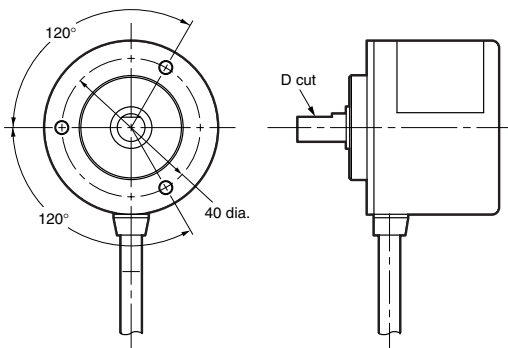

Output Circuit Diagram

Incremental Rotary Encoders

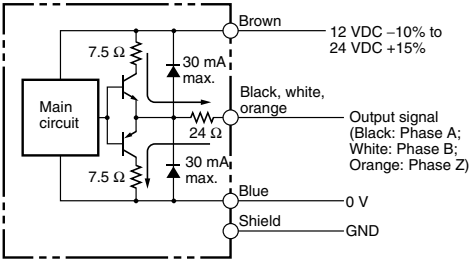
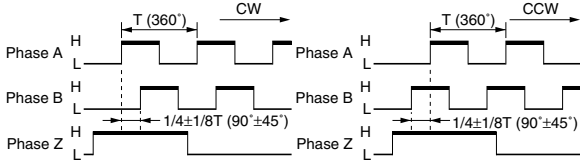
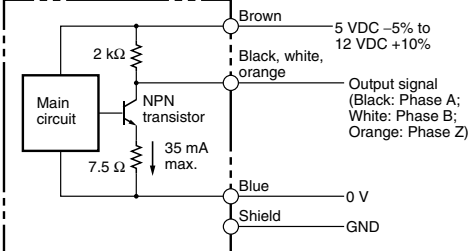
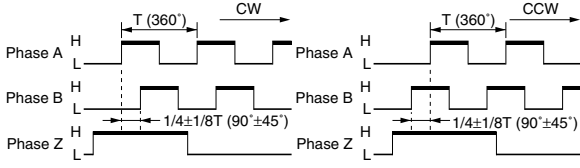
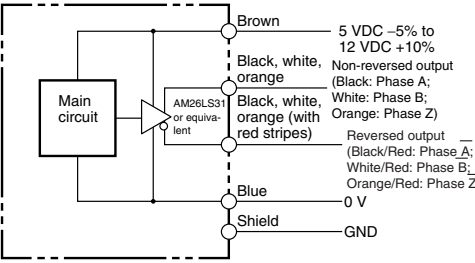
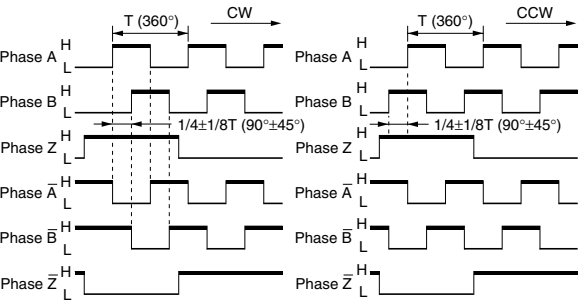
Model/output circuit	Output modes	Connection																		
<p>E6C3-CWZ5GH</p>  <p>12 VDC -10% to 24 VDC +15%</p> <p>Output signal (Black: Phase A; White: Phase B; Orange: Phase Z)</p> <p>0 V</p> <p>GND</p>	<p>Voltage Output: E6C3-CWZ3EH Complementary Output: E6C3-CWZ5GH</p> <p>Rotating direction: Clockwise (CW) (As viewed from the face of the shaft) Rotating direction: Counterclockwise (CCW) (As viewed from the face of the shaft)</p>  <p>Note: Phase A is $1/4 \pm 1/8 T$ faster than phase B. Note: Phase A is $1/4 \pm 1/8 T$ slower than phase B.</p>	<table border="1"> <thead> <tr> <th>Color</th> <th>Terminal</th> </tr> </thead> <tbody> <tr> <td>Brown</td> <td>Power supply (+VCC)</td> </tr> <tr> <td>Black</td> <td>Output phase A</td> </tr> <tr> <td>White</td> <td>Output phase B</td> </tr> <tr> <td>Orange</td> <td>Output phase Z</td> </tr> <tr> <td>Blue</td> <td>0 V (common)</td> </tr> </tbody> </table>	Color	Terminal	Brown	Power supply (+VCC)	Black	Output phase A	White	Output phase B	Orange	Output phase Z	Blue	0 V (common)						
Color	Terminal																			
Brown	Power supply (+VCC)																			
Black	Output phase A																			
White	Output phase B																			
Orange	Output phase Z																			
Blue	0 V (common)																			
<p>E6C3-CWZ3EH</p>  <p>5 VDC -5% to 12 VDC +10%</p> <p>Output signal (Black: Phase A; White: Phase B; Orange: Phase Z)</p> <p>0 V</p> <p>GND</p>	<p>Voltage Output: E6C3-CWZ3EH Complementary Output: E6C3-CWZ5GH</p> <p>Rotating direction: Clockwise (CW) (As viewed from the face of the shaft) Rotating direction: Counterclockwise (CCW) (As viewed from the face of the shaft)</p>  <p>Note: Phase A is $1/4 \pm 1/8 T$ faster than phase B. Note: Phase A is $1/4 \pm 1/8 T$ slower than phase B.</p>	<table border="1"> <thead> <tr> <th>Color</th> <th>Terminal</th> </tr> </thead> <tbody> <tr> <td>Brown</td> <td>Power supply (+VCC)</td> </tr> <tr> <td>Black</td> <td>Output phase A</td> </tr> <tr> <td>White</td> <td>Output phase B</td> </tr> <tr> <td>Orange</td> <td>Output phase Z</td> </tr> <tr> <td>Blue</td> <td>0 V (common)</td> </tr> </tbody> </table>	Color	Terminal	Brown	Power supply (+VCC)	Black	Output phase A	White	Output phase B	Orange	Output phase Z	Blue	0 V (common)						
Color	Terminal																			
Brown	Power supply (+VCC)																			
Black	Output phase A																			
White	Output phase B																			
Orange	Output phase Z																			
Blue	0 V (common)																			
<p>E6C3-CWZ3XH</p>  <p>5 VDC -5% to 12 VDC +10%</p> <p>Non-reversed output (Black: Phase A; White: Phase B; Orange: Phase Z)</p> <p>Reversed output (Black/Red: Phase A; White/Red: Phase B; Orange/Red: Phase Z)</p> <p>0 V</p> <p>GND</p>	<p>Line Driver Output: E6C3-CWZ3XH</p> <p>Rotating direction: Clockwise (CW) (As viewed from the face of the shaft) Rotating direction: Counterclockwise (CCW) (As viewed from the face of the shaft)</p>  <p>Note: Receiver: AM26LS32 equivalent</p>	<table border="1"> <thead> <tr> <th>Color</th> <th>Terminal</th> </tr> </thead> <tbody> <tr> <td>Brown</td> <td>Power supply (+VCC)</td> </tr> <tr> <td>Black</td> <td>Output phase A</td> </tr> <tr> <td>White</td> <td>Output phase B</td> </tr> <tr> <td>Orange</td> <td>Output phase Z</td> </tr> <tr> <td>Black/Red stripes</td> <td>Output phase \bar{A}</td> </tr> <tr> <td>White/Red stripes</td> <td>Output phase \bar{B}</td> </tr> <tr> <td>Orange/Red stripes</td> <td>Output phase \bar{Z}</td> </tr> <tr> <td>Blue</td> <td>0 V (common)</td> </tr> </tbody> </table> <p>Note: Receiver: AM26LS32 equivalent</p>	Color	Terminal	Brown	Power supply (+VCC)	Black	Output phase A	White	Output phase B	Orange	Output phase Z	Black/Red stripes	Output phase \bar{A}	White/Red stripes	Output phase \bar{B}	Orange/Red stripes	Output phase \bar{Z}	Blue	0 V (common)
Color	Terminal																			
Brown	Power supply (+VCC)																			
Black	Output phase A																			
White	Output phase B																			
Orange	Output phase Z																			
Black/Red stripes	Output phase \bar{A}																			
White/Red stripes	Output phase \bar{B}																			
Orange/Red stripes	Output phase \bar{Z}																			
Blue	0 V (common)																			

- Note:**
- The shield is not connected to the internal circuits or casing of the E6C3.
 - There is no difference in circuit among phases A, B, and Z.
 - Connect the GND terminal to 0 V or the ground when the E6C3 is in normal operation.

Connection Examples

Incremental Rotary Encoders

H7ER Digital Tachometer

Applicable Model: E6C3-CWZ3EH (with a resolution of 10, 60, or 600 P/R)

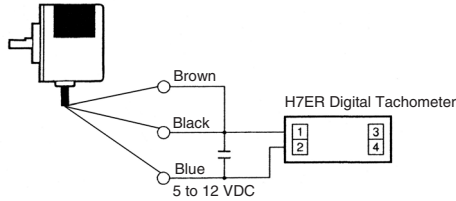

H7BR Digital Counter

Applicable Model: E6C3-CWZ3EH

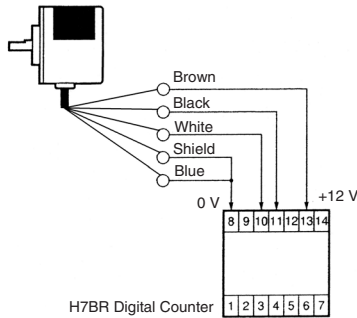

H7CR-CW Digital Counter

Applicable Model: E6C3-CWZ5GH

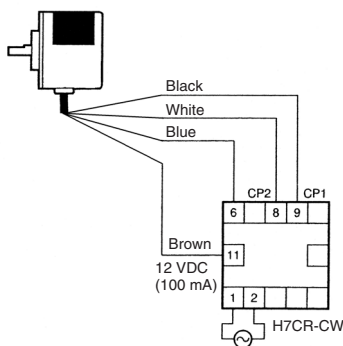

C200H-CT High-speed Counter Unit

Applicable Model: E6C3-CWZ5GH

Typical Model: C200H-CT001-V1

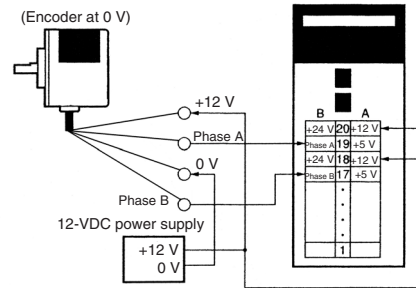

Note: Apply the following connections if the E6C3's 3 power supplies are 5 or 24 V.

Phase A and Power Supply: 5 V to A19 and 24 V to B20
Phase B and Power Supply: 5 V to A17 and 24 V to B18

Applicable Model: E6C3-CWZ5GH

Typical Model: C200H-CT021

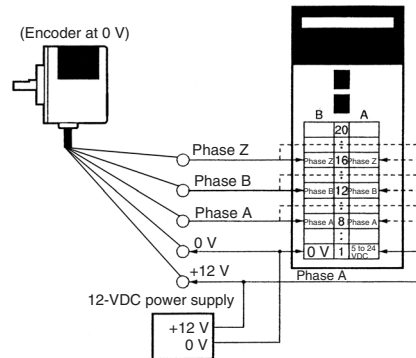

Note: Apply the following connections if the power supply to the E6C3 is 12 or 24 V.

Phase A and Power Supply: 12 V to A8/B8 and 24 V to A9/B9
Phase B and Power Supply: 12 V to A12/B12 and 24 V to A13/B13
Phase Z and Power Supply: 12 V to A16/B16 and 24 V to A17/B17

CQM1-CPU43-EV1 (as Built-in High-speed Counter)

- The pulse output of the E6C3 can be directly input into IN04, IN05, and IN06 of the CPU Unit to use these three points as a built-in high-speed counter.
- The single-phase response speed is 5 kHz and the two-phase response speed is 2.5 kHz. The count value is within a range between 0 and 65,535 in increment mode and -32,767 and 32,767 in decrement mode.
- The operating mode of the high-speed counter is set with the PC Setup in the DM area.

Count Mode

Up/Down mode Increment/Decrement counter uses phases A and B.

Incrementing mode Increment counter uses phase A only.

Normal mode IN04 through IN05 are used for normal input.

Applicable Model: E6C3-CWZ5GH

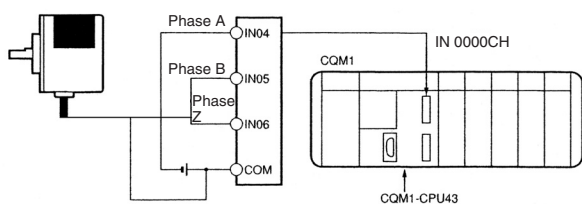

CQM1 Programmable Controller

Applicable Model: E6C3-CWZ5GH

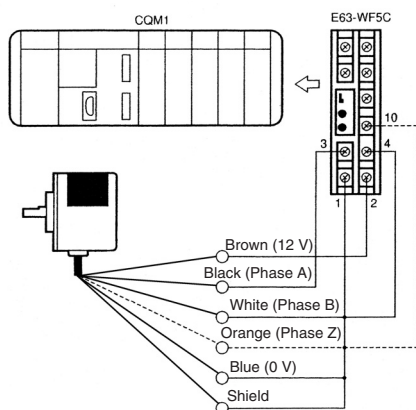

C500-CT001/CT012 High-speed Counter Unit

- CW and CCW detection (increment/decrement counting)
Applicable Model: E6C3-CWZ5GH

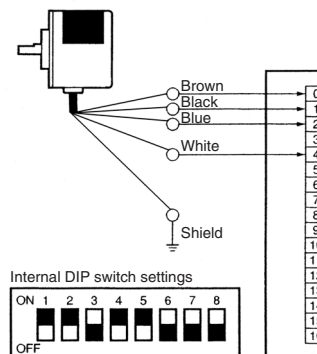

Reset

The present count value can be reset with the soft-reset function or the AND of soft reset and phase Z input.

Output

Target value When the count value reaches the target value, the specified subroutine is executed. A maximum of 16 target values can be set.

Range comparison When the count value is within the range, the specified subroutine is executed. A maximum of 8 ranges can be set with upper and lower limits.

Specifications

■ Ratings/Characteristics

Absolute Rotary Encoders

Item	E6C3-AG5C-C	E6C3-AG5C	E6C3-AN5C	E6C3-AB5C	E6C3-AG5B	E6C3-AN5B	E6C3-AB5B	E6C3-AN1E	E6C3-AN2E	
Power supply voltage	12 VDC-10% to 24 VDC+15%, ripple (p-p) 5% max.							5 VDC ±5%	12 VDC ±10%	
Current consumption	70 mA max.									
Resolution (See note 1.) (pulses/rotation)	256, 360	256, 360, 720, 1,024	32, 40	6, 8, 12	256, 360, 720, 1,024	32, 40	6, 8, 12	256		
Output code	Gray code		Binary	BCD	Gray code	Binary	BCD	Binary		
Output configuration	NPN open collector output				PNP open collector output			Voltage output		
Output capacity	Applied voltage: 30 VDC max. Sink current: 35 mA max. Residual voltage: 0.4 V max. (at sink current of 35 mA)				Source current: 35 mA max. Residual voltage: 0.4 V max. (at Source current of 35 mA)			Output resistance: 2.4 kΩ	Output resistance: 8.2 kΩ	
								Sink current: 35 mA max. Residual voltage: 0.4 V max. (at sink current of 35 mA)		
Rise and fall times of output	1 μs max. (cable length: 2m; output current: 35 mA max.)							Rise: 3 μs max. Fall: 1 μs max.	Rise: 10 μs max. Fall: 1 μs max.	
Max. response frequency (See note 2.)	20 kHz							10 kHz		
Logic	Negative logic output (H=0, L=1)				Positive logic output (H=1, L=0)					
Rotational direction (See note 3.)	Output code incremented by clockwise rotation (as viewed from the face of the shaft.)							Changed using the rotational direction designation input.		
Strobe signal	Not available		Available		Not available	Available		Not available		
Positioning signal	Not available			Available	Not available		Available	Not available		
Parity signal	Not available		Available (even number)	Not available		Available (even number)	Not available			
Starting torque	10 mN·m max. at room temperature 30 mN·m max. at low temperature									
Moment of inertia	2.3 × 10 ⁻⁶ kg·m ²									
Shaft loading	Radial	80 N								
	Thrust	50 N								
Max. permissible rotation	5,000 rpm									
Ambient temperature	Operating: -10°C to 70°C (with no icing) Storage: -25°C to 85°C (with no icing)									
Ambient humidity	35% to 85% (with no condensation)									
Insulation resistance	20 MΩ min. (at 500 VDC) between current-carrying parts and case									
Dielectric strength	500 VAC, 50/60 Hz for 1 min between current-carrying parts and case									
Vibration resistance	10 to 500 Hz, 1.0-mm single amplitude or 150 m/s ² for 11 min. 3 times each in X, Y, and Z directions.									
Shock resistance	1,000 m/s ² , 6 times each in X, Y, and Z directions									
Degree of protection	IEC60529 IP65 (JEM IP65f for drip-proof and oil-proof construction) (See note 4.)									
Connection method	Connector (standard length: 1 m)	Pre-wired (standard length: 1 m)								
Weight (packed state)	Approx. 300 g									
Others	Instruction manual									

Note: 1. The codes are classified as shown in the following table.

Output code	Resolution	Code number
Binary	32	1 to 32
	40	1 to 40
	256	0 to 255
BCD	6	0 to 5
	8	0 to 7
	12	0 to 11
Gray code	256	0 to 255
	360	76 to 435 (Remainder of 76)
	720	152 to 871 (Remainder of 152)
	1,024	0 to 1,023

2. The maximum electrical response revolution is determined by the resolution and maximum response frequency as follows:
 Maximum electrical response frequency (rpm) = Maximum response frequency/resolution × 60
 This means that the E6C3 will not operate electrically if its revolution exceeds the maximum electrical response revolution.
3. With the E6C3-AN1E and E6C3-AN2E models, the output code can be increased in the clockwise direction by connecting the rotational direction designation input (wire color: pink) to H (Vcc), and the output code can be decreased in the clockwise direction by connecting the input to L (0 V).
 E6C3-AN1E: H=1.5 to 5 V, L=0 to 0.8 V
 E6C3-AN2E: H=2.2 to 12 V, L=0 to 1.2 V
 With the E6C3-AN1E and E6C3-AN2E models, read the code at least 10 μs after the LSB (2⁰) code has changed.
4. JEM1030: applicable since 1991.
5. The absolute code's smallest address is output when the relationship between the shaft's D cut position and the cable's pullout direction is as shown in the following diagram. (Output position range: ±15°.)

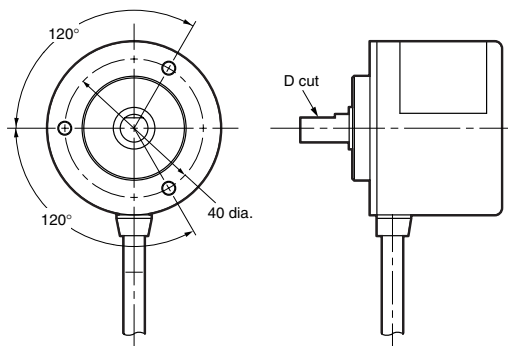

Output Circuit Diagrams

■ Absolute Rotary Encoders

	E6C3-AG5C/-AG5C-C	E6C3-AG5B	E6C3-AN5C	E6C3-AN5B
Output Circuits				
	Note: Each output bit uses the same circuit.	Note: Each output bit uses the same circuit.	Note: Each output bit uses the same circuit.	Note: Each output bit uses the same circuit.
Output Modes	Rotating direction: CW, as viewed from the face of the shaft.		Rotating direction: CW, as viewed from the face of the shaft. Resolution: 40	

Connections

■ Connector Specifications

Pin number	E6C3-AG5C-C	
	Output signal	
	8-bit (256)	9-bit (360)
1	Connected internally	NC
2		2 ⁸
3	2 ⁵	2 ⁵
4	2 ¹	2 ¹
5	2 ⁰	2 ⁰
6	2 ⁷	2 ⁷
7	2 ⁴	2 ⁴
8	2 ²	2 ²
9	2 ³	2 ³
10	2 ⁶	2 ⁶
11	Shield (GND)	
12	12 to 24 VDC	
13	0 V (Common)	

Note: Connector type: RP13A-12PD-13SC (Hirose Electric)

■ Cable Specifications

Wire color	E6C3-AG5C/E6C3-AG5B		
	Output signal		
	8-bit (256)	9-bit (360)	10-bit (720, 1,024)
Brown	2 ⁰	2 ⁰	2 ⁰
Orange	2 ¹	2 ¹	2 ¹
Yellow	2 ²	2 ²	2 ²
Green	2 ³	2 ³	2 ³
Blue	2 ⁴	2 ⁴	2 ⁴
Purple	2 ⁵	2 ⁵	2 ⁵
Gray	2 ⁶	2 ⁶	2 ⁶
White	2 ⁷	2 ⁷	2 ⁷
Pink	NC	2 ⁸	2 ⁸
Light blue	NC	NC	2 ⁹
---	Shield (GND)		
Red	12 to 24 VDC		
Black	0 V (Common)		

Output Circuit Diagrams

Absolute Rotary Encoders

	E6C3-AB5C	E6C3-AB5B	E6C3-AN1E	E6C3-AN2E
Output Circuits	<p>Note: Each output bit uses the same circuit.</p>	<p>Note: Each output bit uses the same circuit.</p>	<p>Note: Each output bit uses the same circuit.</p>	<p>Note: Each output bit uses the same circuit.</p>
			<p>Rotational Direction Designation Input Circuit</p> <p>Note: Output code increases in the clockwise direction when the input is connected to Vcc and decreases in the clockwise direction when the input is connected to 0 V.</p>	
Output Modes	<p>Rotating direction: CW, as viewed from the face of the shaft. Resolution: 12</p> <p>When resolution is 8 A=45° B=22.5° C=11.25°</p> <p>When resolution is 6 A=60° B=30° C=15°</p>		<p>Rotating direction: CW, as viewed from the face of the shaft, when rotational direction designation input is at "H." CCW, as viewed from the face of the shaft, when rotational direction designation input is at "L."</p> <p>Shaft angle: $360^\circ \left(\frac{360}{256} \right)^\circ$</p> <p>$T = 360^\circ / 256 = 1.4^\circ$</p>	

Connections

■ Cable Specifications

Wire color	E6C3-AN5C/-AN5B		E6C3-AB5C/-AB5B		E6C3-AN1E/-AN2E
	Output signal		Output signal		Output signal
	6-bit (32, 40)		3-bit (6, 8)	5-bit (12)	8-bit (256)
Brown	2 ⁰	2 ⁰	2 ⁰	2 ⁰	2 ⁰
Orange	2 ¹	2 ¹	2 ¹	2 ¹	2 ¹
Yellow	2 ²	2 ²	2 ²	2 ²	2 ²
Green	2 ³	NC	2 ³	2 ³	2 ³
Blue	2 ⁴	NC	2 ⁰ × 10	2 ⁴	2 ⁴
Purple	2 ⁵	NC	NC	2 ⁵	2 ⁵
Gray	Parity	Positioning	Positioning	2 ⁶	2 ⁶
White	Strobe	Strobe	Strobe	2 ⁷	2 ⁷
Pink	NC	NC	NC	Rotational direction designation input	
Light blue	NC	NC	NC	NC	
---	Shield (GND)				
Red	12 to 24 VDC				5, 12 VDC
Black	0 V (Common)				

Connection Examples

■ Connecting an Absolute Rotary Encoder to an H8PS Cam Positioner

H8PS-8A, -8AP, -8AF, -A8AF

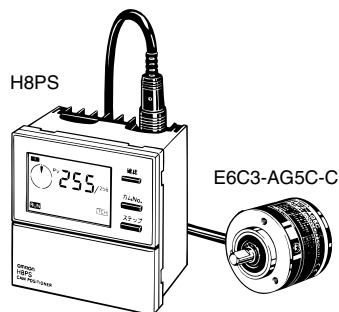

Specifications

Rated voltage	24 VDC
Cam resolution	1.4° (a resolution of 256 per rotation)
Outputs	8 cam outputs 1 RUN output 1 tachometer output
Encoder response	330 rpm
Functions	Origin compensation (zero shift) Rotating direction selection Angle display selection Teaching

■ Connecting E6C3-AG5C to Programmable Controller

System Configuration Using a Resolution of 1,024 per Rotation

A combination of the CQM1-CPU44-E and E6C3-AG5C ensures easy output angle setting for cam control in 360° or BCD mode.

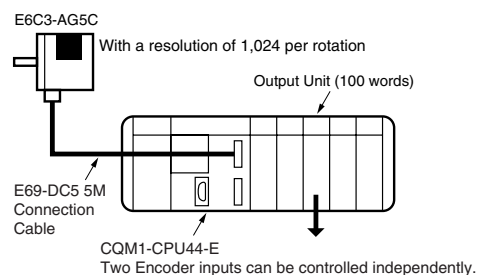

Mode Setting of CQM1-CPU44-E

Set port 1 to BCD mode and 10 bits

DM 6643

Output Timing

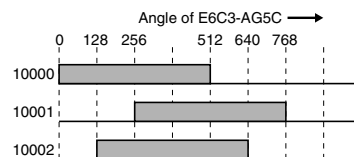

Ladder Program Example

Use the CTBL instruction of the CQM1-CPU44-E to register a maximum of eight comparison tables for output angle setting.

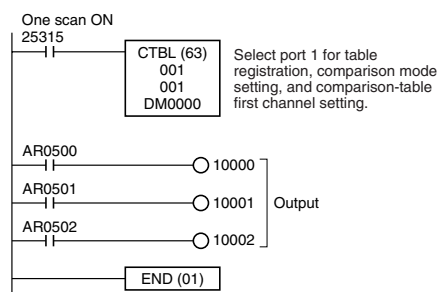

Example of DM Setting for Comparison Table

DM 0000	0000	Lower limit 1	} Bit AR 0500
0001	0512	Upper limit 1	
0002	0000	Subroutine number 1	} Bit AR 0501
0003	0256	Lower limit 2	
0004	0768	Upper limit 2	} Bit AR 0502
0005	0000	Subroutine number 2	
0006	0128	Lower limit 3	} Bit AR 0502
0007	0640	Upper limit 3	
0008	0000	Subroutine number 3	} Not used.
0009	0000	Lower limit 4	
0022	0000	Upper limit 8	} Not used.
0023	0000	Subroutine number 8	

Note: An upper or lower limit can be set with integers in BCD mode and 5° increments in 360° mode. Subroutine numbers are set for interrupt processing.

Internal Bits of CQM1-CPU44-E

- **Range Comparison Result**
Each bit of the CQM1-CPU44-E CPU Unit's words AR 05 and AR 06 turns ON only when the comparison range coincides with the angle of E6C3-AG5C. If it does not coincide, the bit turns (remains) OFF.

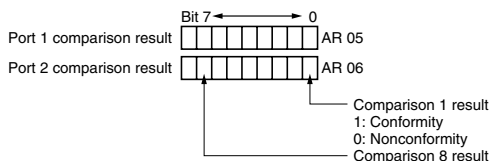

- **Present Value Read**
The gray code signals of the E6C3-AG5C are automatically converted into BCD or 360° code signals and read through the CQM1-CPU44-E CPU Unit's words AR 232 and AR 234. The present value can be used for ladder programs.

Port 1 angle ******** Word 232
 Port 2 angle ******** Word 234

Note: For details on the CQM1-CPU44-E, refer to the *CQM1 Programming Manual (W228)*.

■ Absolute Rotary Encoders

Connecting to CPM1A Using a Resolution of 720 per Rotation

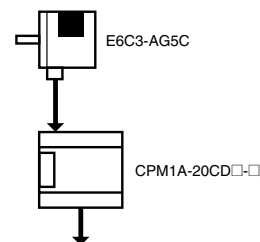

Wiring Between E6C3-AG5C and CPM1A

Output signal from E6C3-AG5C	Input signal to CPM1A
Brown (2 ⁰)	00000
Orange (2 ¹)	00001
Yellow (2 ²)	00002
Green (2 ³)	00003
Blue (2 ⁴)	00004
Purple (2 ⁵)	00005
Gray (2 ⁶)	00006
White (2 ⁷)	00007
Pink (2 ⁸)	00008
Light blue (2 ⁹)	00009

Output Timing

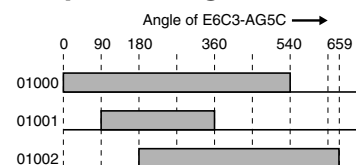

Ladder Program

Example of DM Setting for Comparison Table

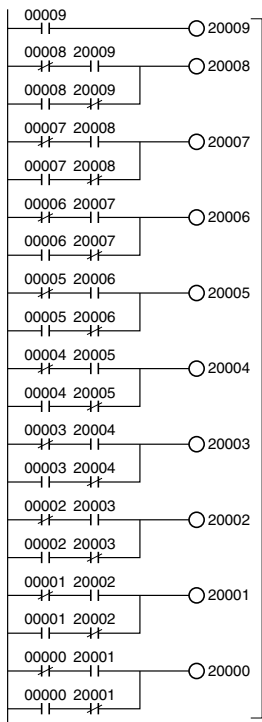

Converts a gray code signal into a BIN code signal (word 200).

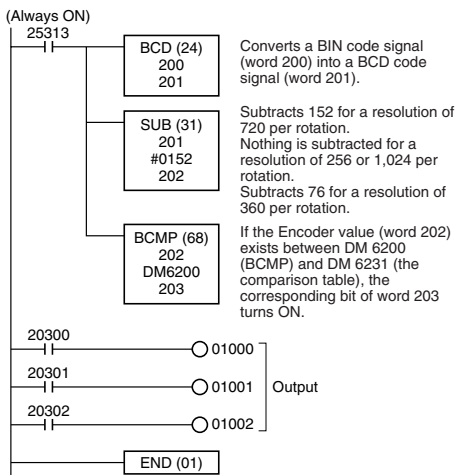

DM 6200	0000	Lower limit 1	} Bit 20300
6201	0540	Upper limit 1	
6202	0090	Lower limit 2	} Bit 20301
6203	0360	Upper limit 2	
6204	0180	Lower limit 3	} Bit 20302
6205	0659	Upper limit 3	
6206	0000	Lower limit 4	} Not used.
6231	0000	Upper limit 16	

Precautions

■ Incremental and Absolute Encoders

Safety Precautions

Do not impose voltage exceeding the rated voltage range on the E6C3, otherwise the E6C3 may be damaged.

Do not wire power lines or high-tension lines along with the power supply lines of the E6C3 or the E6C3 may be damaged or malfunction.

If the power supply has surge voltage, connect a surge suppressor between the positive and negative terminals of the power supply to absorb the surge voltage. Also, in order to protect the E6C3 from noise, shorten the wires connected to the E6C3 as much as possible.

Unnecessary pulses are output at the time the E6C3 is turned ON or OFF. After turning ON the E6C3, be sure to wait 0.1 s before turning ON the peripheral devices connected to the E6C3 and turn OFF the peripheral devices 0.1 s before turning OFF the E6C3.

Application Precautions

Mounting

Mounting Precautions

- Be careful not to spray water or oil onto the E6C3.
- The E6C3 consists of high-precision components. Handle with utmost care and do not drop the E6C3, otherwise malfunctioning may result.
- When the E6C3 is used in reversed operation, pay utmost attention to the mounting direction of the E6C3 and the directions of increment and decrement rotation.
- To match phase Z of the E6C3 and the origin of the device to be connected to the E6C3, conform the phase Z outputs while connecting the device.
- Be careful not to impose an excessive load on the shaft if the shaft connects to a gear.
- If the E6C3 is mounted with screws, the tightening torque must not exceed approximately 0.5 N·m.
- If the E6C3 is mounted to a panel, do not pull the cable with more than a force of 30 N. Do not subject the E6C3 or the shaft to excessive shock.

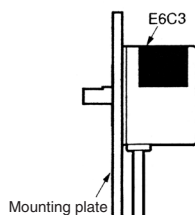

- No shock must be given to the shaft or coupling. Therefore, do not hit the shaft or coupling with a hammer when inserting the shaft into the coupling.

- When connecting the coupling, stay within the ranges shown below

<p>Decentering tolerance</p>	
<p>Declination tolerance</p>	
<p>Displacement tolerance in the shaft direction</p>	

- When connecting or disconnecting the coupling, do not impose an excessive bending, pressing, or pulling force on the E6C3.
- When connecting the shaft of the E6C3 with a chain timing belt or gear, connect the chain timing belt or gear with the shaft via the bearing and coupling as shown in the following illustration.

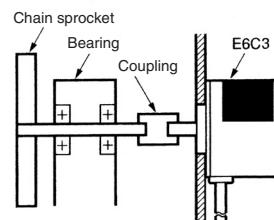

- If the decentering or declination value exceeds the tolerance, an excessive load imposed on the shaft may damage or shorten the life of the E6C3.

Mounting Procedure

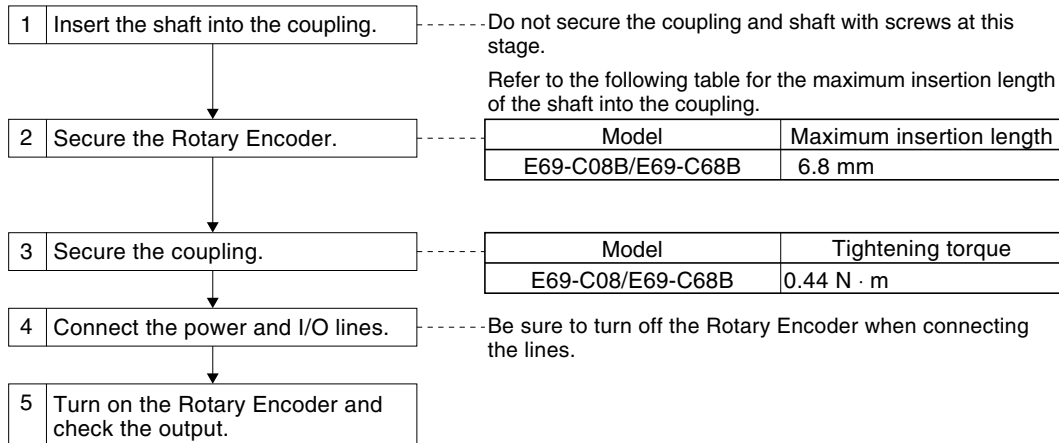

Life of Bearing

The following graph shows the (theoretical) life expectancy of the bearing with radial and thrust loads imposed on the bearing.

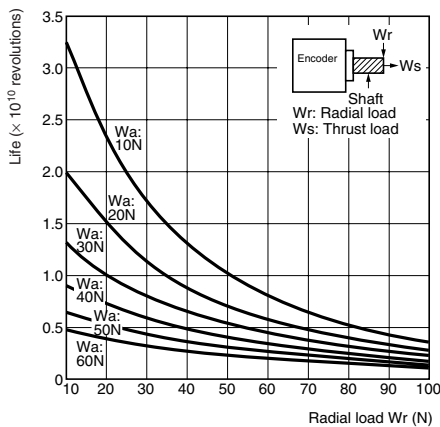

Wiring

Connecting

- When extending the cable for Incremental Rotary Encoders, select the kind of cable with care by taking the response frequency into consideration because the longer the cable is, the more the residual voltage increases due to the resistance of the cable and the capacitance between the wires. As a result, the waveform will be distorted.

We recommend the line driver output type model (E6C3-CWZ3XH) or the complementary output type model (E6C3-CWZ5GH) if the cable needs to be extended.

In order to reduce inductive noise, the cable must be as short as possible, especially when the signal is input to an IC.

- If the power supply has surge voltage, connect a surge suppressor between the positive and negative terminals of the power supply to absorb the surge voltage.
- Unnecessary pulses are output at the time the E6C3 is turned ON or OFF. After turning ON the E6C3, be sure to wait 0.1 s before turning ON the peripheral devices connected to the E6C3 and turn OFF the peripheral devices 0.1 s before turning OFF the E6C3.

Cable Extension

- The rise time of each output waveform will increase when the cable is extended. This affects the phase difference characteristics of phases A and B.
- The available length of cable varies with the response frequency and noise. It is safer to limit the length of cable to 10 m maximum. If a longer cable of up to 100 m is required, use the line driver output or complementary output model. (The maximum extension with the line driver output model is 100 m.)

Note: Recommended Cable:

Cross section: 0.2 mm² with spiral shield
Conductor resistance: 92 Ω/km max. at 20°C
Insulation resistance: 5 MΩ/km min. at 20°C

- The rise time varies with the resistance of the cable and the kind of cable as well as the length of the cable.
- The residual output voltage will increase according to the length of the cable.

Preventing Miscounting

If the operation of the E6C3 is stopped near a signal rising or falling edge, a wrong pulse may be generated, in which case the E6C3 will miscount. In such a case, use an increment-decrement counter to prevent miscounting.

Extension of Line Driver Output

- Be sure to use a shielded twisted-pair cable to extend a line driver cable.
Recommended cable: Tachii Electric Wire Co., TKVVBS4P 02A
- Use an RS-422A Receiver for the receiver side.
- The twisted-pair wires as shown in the following illustration are suitable for RS-422A signal transmission. Normal mode noise can be eliminated by twisting the wires because the generated electrical forces on the lines cancel each other.

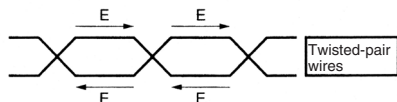

- Be sure the E6C3 is supplied with 5 VDC when a line driver output is used. There will be an approximately 1-V voltage drop if the cable length is 100 m.

Input to More than One Counter from Encoder (with Voltage Output)

Use the following formula to obtain the number of counters to be connected to a single E6C3.

$$\text{Number of counters (N)} = \frac{R1 (E-V)}{V \times R2}$$

E: Voltage supplied to E6C3
 V: Minimum input voltage of the counter
 R1: Input resistance of the Counter
 R2: Output resistance of the E6C3

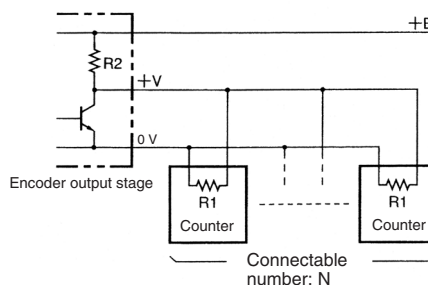

Dimensions

Unit: mm (inch)

Rotary Encoder

E6C3-CWZ□□H

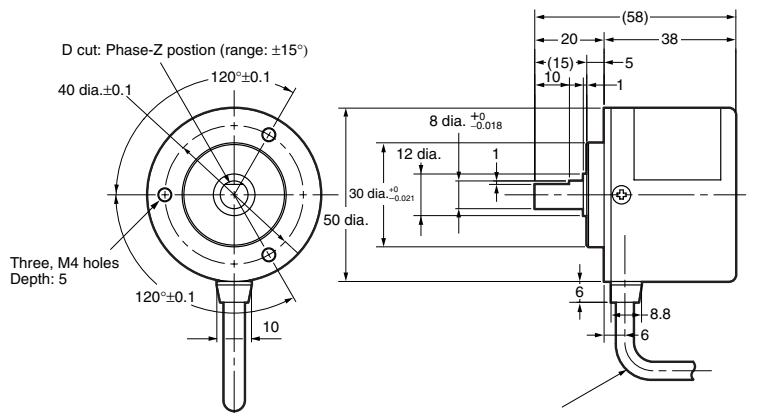
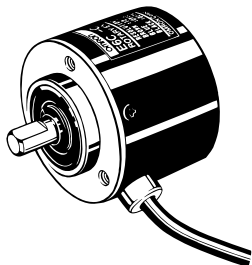

5 dia. oil-proof PVC, shielded 5-conductor cable (8-conductor for line driver)
 (conductor cross-section: 0.2 mm²; insulation diameter: 1.1 mm)
 Standard length: 1 m

E6C3-A□5□

E6C3-AN□E

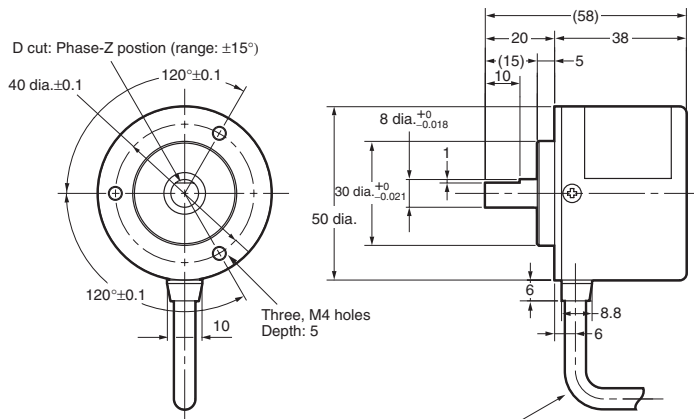
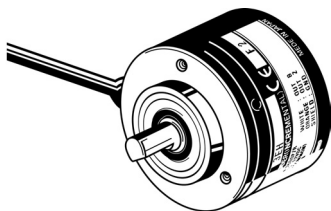

6 dia. oil-proof PVC, shielded 12-conductor cable
 (conductor cross-section: 0.2 mm²; insulation diameter: 1.1 mm)
 Standard length: 1 m

Note: E69-C08B Coupling is sold separately.

E6C3-AG5C-C

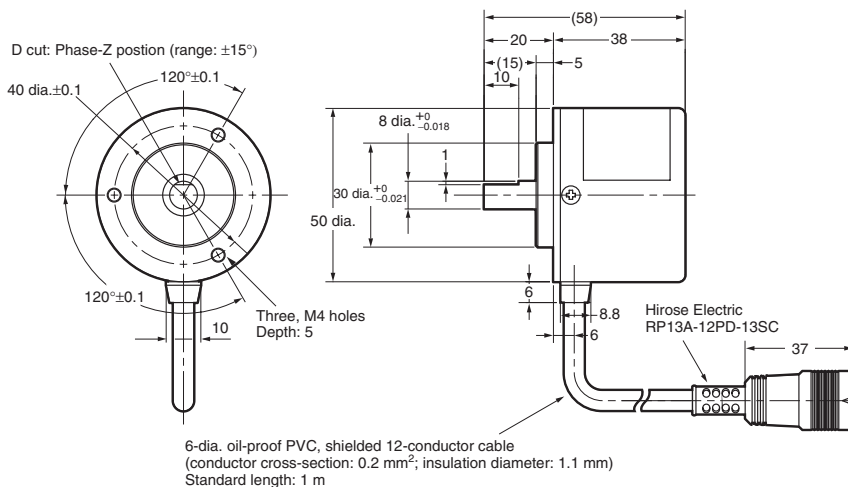

Note: E69-C08B Coupling is sold separately.

Accessories (Order Separately)

Extension Cable E69-DF5

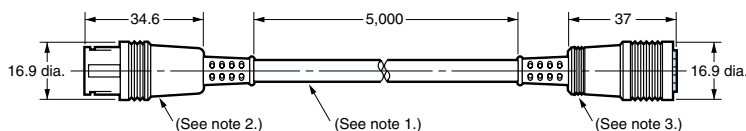

- Note 1: 6-dia. oil-proof PVC, shielded 12-conductor cable (conductor cross-section: 0.2 mm^2 ; insulation diameter: 1.1 mm); standard length: 5 m
 2: Connects to the connector of the E6C3-AG5C-C.
 3: Connects to the H8PR Rotary Positioner and H8PS Cam Positioner.

Note: The Cable can be extended up to 100 m for connecting the H8PS Cam Positioner.

E69-C08B

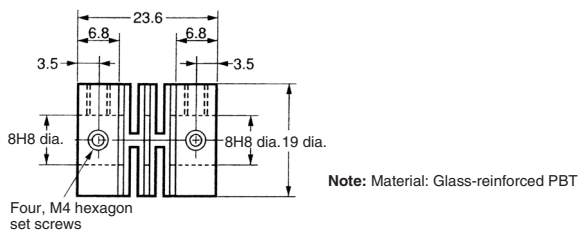

E69-C68B (With Ends of Different Diameter)

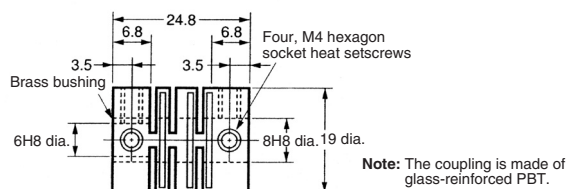

Certain Terms and Conditions of Sale

1. **Offer; Acceptance.** These terms and conditions (these "Terms") are deemed part of all catalogs, manuals or other documents, whether electronic or in writing, relating to the sale of goods or services (collectively, the "Goods") by Omron Electronics LLC and its subsidiary companies ("Seller"). Seller hereby objects to any terms or conditions proposed in Buyer's purchase order or other documents which are inconsistent with, or in addition to, these Terms. Please contact your Omron representative to confirm any additional terms for sales from your Omron company.
2. **Prices.** All prices stated are current, subject to change without notice by Seller. Buyer agrees to pay the price in effect at time of shipment.
3. **Discounts.** Cash discounts, if any, will apply only on the net amount of invoices sent to Buyer after deducting transportation charges, taxes and duties, and will be allowed only if (i) the invoice is paid according to Seller's payment terms and (ii) Buyer has no past due amounts owing to Seller.
4. **Orders.** Seller will accept no order less than \$200 net billing.
5. **Governmental Approvals.** Buyer shall be responsible for, and shall bear all costs involved in, obtaining any government approvals required for the importation or sale of the Goods.
6. **Taxes.** All taxes, duties and other governmental charges (other than general real property and income taxes), including any interest or penalties thereon, imposed directly or indirectly on Seller or required to be collected directly or indirectly by Seller for the manufacture, production, sale, delivery, importation, consumption or use of the Goods sold hereunder (including customs duties and sales, excise, use, turnover and license taxes) shall be charged to and remitted by Buyer to Seller.
7. **Financial.** If the financial position of Buyer at any time becomes unsatisfactory to Seller, Seller reserves the right to stop shipments or require satisfactory security or payment in advance. If Buyer fails to make payment or otherwise comply with these Terms or any related agreement, Seller may (without liability and in addition to other remedies) cancel any unshipped portion of Goods sold hereunder and stop any Goods in transit until Buyer pays all amounts, including amounts payable hereunder, whether or not then due, which are owing to it by Buyer. Buyer shall in any event remain liable for all unpaid accounts.
8. **Cancellation; Etc.** Orders are not subject to rescheduling or cancellation unless Buyer indemnifies Seller fully against all costs or expenses arising in connection therewith.
9. **Force Majeure.** Seller shall not be liable for any delay or failure in delivery resulting from causes beyond its control, including earthquakes, fires, floods, strikes or other labor disputes, shortage of labor or materials, accidents to machinery, acts of sabotage, riots, delay in or lack of transportation or the requirements of any government authority.
10. **Shipping; Delivery.** Unless otherwise expressly agreed in writing by Seller:
 - a. Shipments shall be by a carrier selected by Seller;
 - b. Such carrier shall act as the agent of Buyer and delivery to such carrier shall constitute delivery to Buyer;
 - c. All sales and shipments of Goods shall be FOB shipping point (unless otherwise stated in writing by Seller), at which point title to and all risk of loss of the Goods shall pass from Seller to Buyer, provided that Seller shall retain a security interest in the Goods until the full purchase price is paid by Buyer;
 - d. Delivery and shipping dates are estimates only.
 - e. Seller will package Goods as it deems proper for protection against normal handling and extra charges apply to special conditions.
11. **Claims.** Any claim by Buyer against Seller for shortage or damage to the Goods occurring before delivery to the carrier must be presented in writing to Seller within 30 days of receipt of shipment and include the original transportation bill signed by the carrier noting that the carrier received the Goods from Seller in the condition claimed.
12. **Warranties.** (a) **Exclusive Warranty.** Seller's exclusive warranty is that the Goods will be free from defects in materials and workmanship for a period of twelve months from the date of sale by Seller (or such other period expressed in writing by Seller). Seller disclaims all other warranties, express or implied. (b) **Limitations.** SELLER MAKES NO WARRANTY OR REPRESENTATION, EXPRESS OR IMPLIED, ABOUT NON-INFRINGEMENT, MERCHANTABILITY OR FITNESS FOR A PARTICULAR PURPOSE OF THE GOODS. BUYER ACKNOWLEDGES THAT IT ALONE HAS DETERMINED THAT THE GOODS WILL SUITABLY MEET THE REQUIREMENTS OF THEIR INTENDED USE. Seller further disclaims all warranties and responsibility of any type for claims or expenses based on infringement by the Goods or otherwise of any intellectual property right. (c) **Buyer Remedy.** Seller's sole obligation hereunder shall be to replace (in the form originally shipped with Buyer responsible for labor charges for removal or replacement thereof) the non-complying Good or, at Seller's election, to repay or credit Buyer an amount equal to the purchase price of the Good; provided that in no event shall Seller be responsible for warranty, repair, indemnity or any other claims or expenses regarding the Goods unless Seller's analysis confirms that the Goods were properly handled, stored, installed and maintained and not subject to contamination, abuse, misuse or inappropriate modification. Return of any goods by Buyer must be approved in writing by Seller before shipment. Seller shall not be liable for the suitability or unsuitability or the results from the use of Goods in combination with any electrical or electronic components, circuits, system assemblies or any other materials or substances or environments. Any advice, recommendations or information given orally or in writing, are not to be construed as an amendment or addition to the above warranty.
13. **Damage Limits; Etc.** SELLER SHALL NOT BE LIABLE FOR SPECIAL, INDIRECT OR CONSEQUENTIAL DAMAGES, LOSS OF PROFITS OR PRODUCTION OR COMMERCIAL LOSS IN ANY WAY CONNECTED WITH THE GOODS, WHETHER SUCH CLAIM IS BASED IN CONTRACT, WARRANTY, NEGLIGENCE OR STRICT LIABILITY. Further, in no event shall liability of Seller exceed the individual price of the Good on which liability is asserted.
14. **Indemnities.** Buyer shall indemnify and hold harmless Seller, its affiliates and its employees from and against all liabilities, losses, claims, costs and expenses (including attorney's fees and expenses) related to any claim, investigation, litigation or proceeding (whether or not Seller is a party) which arises or is alleged to arise from Buyer's acts or omissions under these Terms or in any way with respect to the Goods. Without limiting the foregoing, Buyer (at its own expense) shall indemnify and hold harmless Seller and defend or settle any action brought against Seller to the extent that it is based on a claim that any Good made to Buyer specifications infringed intellectual property rights of another party.
15. **Property; Confidentiality.** The intellectual property embodied in the Goods is the exclusive property of Seller and its affiliates and Buyer shall not attempt to duplicate it in any way without the written permission of Seller. Notwithstanding any charges to Buyer for engineering or tooling, all engineering and tooling shall remain the exclusive property of Seller. All information and materials supplied by Seller to Buyer relating to the Goods are confidential and proprietary, and Buyer shall limit distribution thereof to its trusted employees and strictly prevent disclosure to any third party.
16. **Miscellaneous.** (a) **Waiver.** No failure or delay by Seller in exercising any right and no course of dealing between Buyer and Seller shall operate as a waiver of rights by Seller. (b) **Assignment.** Buyer may not assign its rights hereunder without Seller's written consent. (c) **Amendment.** These Terms constitute the entire agreement between Buyer and Seller relating to the Goods, and no provision may be changed or waived unless in writing signed by the parties. (d) **Severability.** If any provision hereof is rendered ineffective or invalid, such provision shall not invalidate any other provision. (e) **Setoff.** Buyer shall have no right to set off any amounts against the amount owing in respect of this invoice. (f) As used herein, "including" means "including without limitation".

Certain Precautions on Specifications and Use

1. **Suitability of Use.** Seller shall not be responsible for conformity with any standards, codes or regulations which apply to the combination of the Good in the Buyer's application or use of the Good. At Buyer's request, Seller will provide applicable third party certification documents identifying ratings and limitations of use which apply to the Good. This information by itself is not sufficient for a complete determination of the suitability of the Good in combination with the end product, machine, system, or other application or use. The following are some examples of applications for which particular attention must be given. This is not intended to be an exhaustive list of all possible uses of this Good, nor is it intended to imply that the uses listed may be suitable for this Good:
 - (i) Outdoor use, uses involving potential chemical contamination or electrical interference, or conditions or uses not described in this document.
 - (ii) Energy control systems, combustion systems, railroad systems, aviation systems, medical equipment, amusement machines, vehicles, safety equipment, and installations subject to separate industry or government regulations.
 - (iii) Systems, machines and equipment that could present a risk to life or property. Please know and observe all prohibitions of use applicable to this Good.

NEVER USE THE PRODUCT FOR AN APPLICATION INVOLVING SERIOUS RISK TO LIFE OR PROPERTY WITHOUT ENSURING THAT THE SYSTEM AS A WHOLE HAS BEEN DESIGNED TO ADDRESS THE RISKS, AND THAT THE SELLER'S PRODUCT IS PROPERLY RATED AND INSTALLED FOR THE INTENDED USE WITHIN THE OVERALL EQUIPMENT OR SYSTEM.
2. **Programmable Products.** Seller shall not be responsible for the user's programming of a programmable Good, or any consequence thereof.
3. **Performance Data.** Performance data given in this catalog is provided as a guide for the user in determining suitability and does not constitute a warranty. It may represent the result of Seller's test conditions, and the user must correlate it to actual application requirements. Actual performance is subject to the Seller's Warranty and Limitations of Liability.
4. **Change in Specifications.** Product specifications and accessories may be changed at any time based on improvements and other reasons. It is our practice to change part numbers when published ratings or features are changed, or when significant construction changes are made. However, some specifications of the Good may be changed without any notice. When in doubt, special part numbers may be assigned to fix or establish key specifications for your application. Please consult with your Seller's representative at any time to confirm actual specifications of purchased Good.
5. **Errors and Omissions.** The information in this catalog has been carefully checked and is believed to be accurate; however, no responsibility is assumed for clerical, typographical or proofreading errors, or omissions.

Complete "Terms and Conditions of Sale" for product purchase and use are on Omron's website at www.omron.com/oei – under the "About Us" tab, in the Legal Matters section.

ALL DIMENSIONS SHOWN ARE IN MILLIMETERS.

To convert millimeters into inches, multiply by 0.03937. To convert grams into ounces, multiply by 0.03527.

OMRON[®]**OMRON ELECTRONICS LLC**

One Commerce Drive
Schaumburg, IL 60173

847-843-7900

For US technical support or other inquiries:

800-556-6766**OMRON CANADA, INC.**

885 Milner Avenue
Toronto, Ontario M1B 5V8

416-286-6465**OMRON ON-LINE**

Global - <http://www.omron.com>
USA - <http://www.omron.com/oei>
Canada - <http://www.omron.ca>