

C4V

Miniature Power Switch

Miniature Power Switch with Contact gap of 3 mm min.

- Unique snap-action mechanism allows large-capacity switching.
- Sharp snap feeling with firm switching action.
- Contact gap of 3 mm min.
- UL, cUL standards approved. Conforms to EN standards.

RoHS Compliant (Please refer to "Precautions" for details.)

Typical Applications

- Power Switching
- Door Interlock

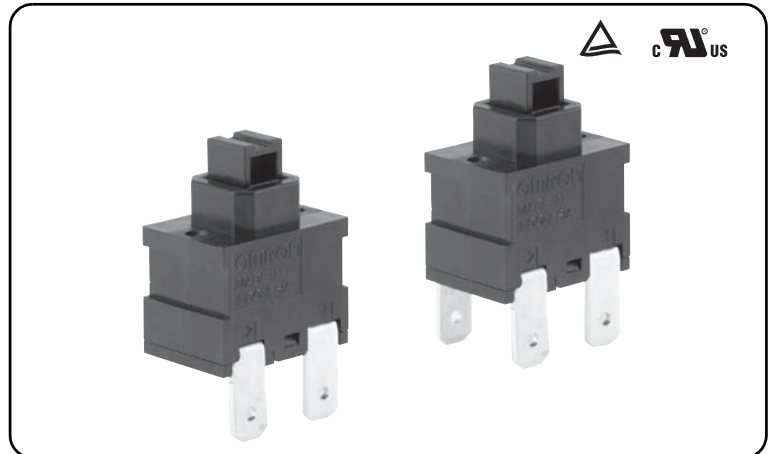

C
4
V

Ordering Information

Switching Functions	Momentary		Alternate	
	SPST	DPST	SPST	DPST
Contact Forms				
Models	C4V-811M-D	C4V-821M	C4V-811A-D	C4V-821A

Specifications

Rating (resistive load)	8A 125/250 VAC	
Ambient temperature	-10°C to +55°C 60%RH max. (with no icing or condensation)	
Ambient humidity	45 to 85%RH (at +5 to 35°C)	
Insulation resistance	100 MΩ min. (at 500 VDC with insulation tester)	
Contact resistance (initial value)	50 mΩ max. (at 6 VDC 1A)	
Dielectric strength	Between terminals of the same polarity	3,000 VAC 50/60Hz 1 min
	Between terminals of different polarity	3,000 VAC 50/60Hz 1 min
	Between current-carrying metal parts and ground	3,000 VAC 50/60Hz 1 min
Vibration resistance	Malfunction	10 to 55 Hz, 1.5 mm double amplitude
Shock resistance	Malfunction	147 m/s ² min.
Durability	Mechanical	10,000 operations min.
	Electrical	10,000 operations min.
Degree of protection	IEC IP00	
Operating force	7 N {714 gf} max.	

Approved Safety Standard

- **UL (UL1054/CSA C22.2 No.55)**
8A 250 VAC
- **TÜV (EN61058-1)**
8A 250 VAC

Dimensions

(Units: mm)

●SPST

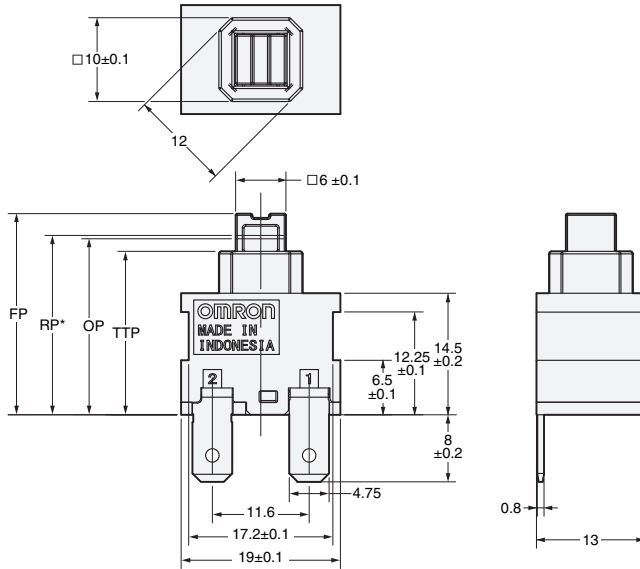

Operating Force	OF	7 N {714 gf} max.
Free Position	FP	24.0±0.2mm
Operating Position	OP	21mm min.
Total Travel Position	TTP	19.5±0.2mm
Releasing Position	RP	21.5mm min.
Set Position	SP	21.4±0.3mm

* mark part: In case of the alternative model, "RP" means "SP"

●DPST

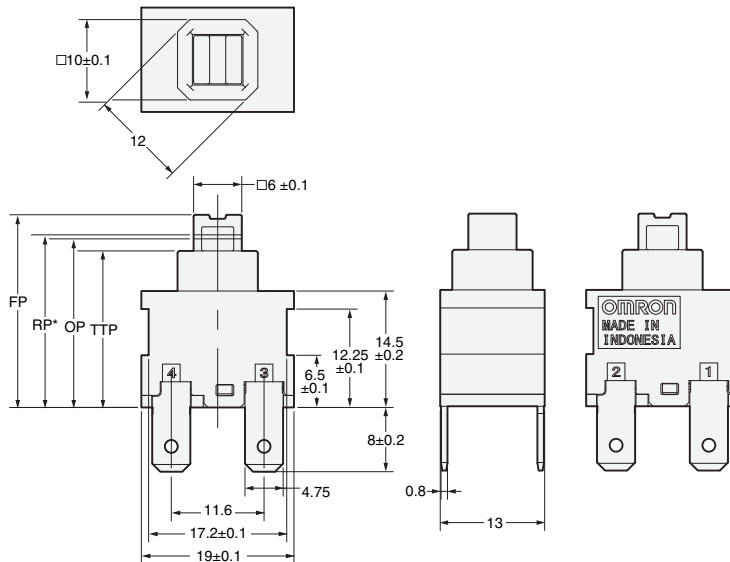

Operating Force	OF	7 N {714 gf} max.
Free Position	FP	24.0±0.2mm
Operating Position	OP	21mm min.
Total Travel Position	TTP	19.5±0.2mm
Releasing Position	RP	21.5mm min.
Set Position	SP	21.4±0.3mm

* mark part: In case of the alternative model, "RP" means "SP"

Note. Unless otherwise specified, a tolerance of ±0.4 mm applies to all dimensions described in the above figure.

Operating specifications/Internal connection

●SPST



●DPST



Panel Cutout

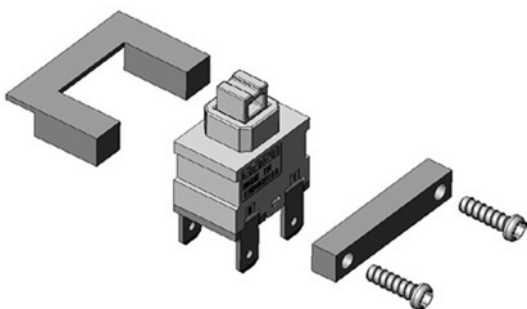

The above figure is an example of the mounting method.

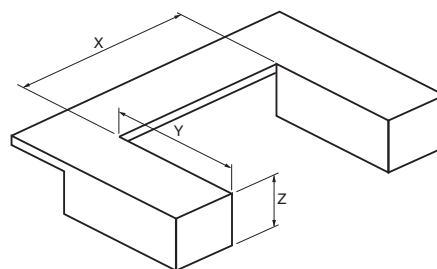

Direction	Dimensions (mm)
X	17.4 ^{+0.15} ₀
Y	13.2 ^{+0.15} ₀
Z	5.5 ⁰ _{-0.15}

Precautions

Warning

Please do not perform wiring or touch the charged parts of terminals while power is supplied to the Switch, as electric shock may occur.



Caution

- Use the switch within the rated voltage and current ranges, otherwise the switch may have reduced durability, radiate heat, or burn out.
This particularly applies to the instantaneous voltages and currents when switching.

Correct Use

●Mounting

- Pay attention to the creepage distance/clearance distance for insulation after wiring onto terminal when mounting frame is made of metal.

●Wiring

- Please use the receptacle that is compatible with 4.8×0.8 mm quick connect terminal (#187) when using it as a quick connect terminal.
- Ensure that the wires are thick enough for the load (current) to be applied.
- The performance of the Switch may be affected if used under micro loads. Please test the Switch under actual operating conditions.
- It is possible to use the terminals as a soldering terminal. However, it is not in compliance with safety standards for use as solder connection.
Please use it as the quick connect terminal when standard approval is necessary.
- When soldering terminals manually, perform soldering within 5 seconds using a 60 W soldering iron (temperature at the tip of the soldering iron: 350°C max.). Do not apply excessive force to the terminals during soldering.
- Applying the tip of the soldering iron to the root side of the terminal can cause deformation of the Housing and Base.
- This product does not correspond to the flow solder and reflow solder.
It causes the malfunction by the infiltration of flux and the thermal deformation.

●Environment for Storage and Use

- To prevent deterioration such as discoloration of the terminals and other problems during storage, do not store/use the switch in location subject to the following conditions.
 1. High temperatures or humidity
 2. Corrosive gases
 3. Direct sunlight
 4. Sea wind
 Also, the switch is not waterproof or splash-resistant. Do not install or use the switch in locations that are subject to contact with water, oil or dust.
- Do not subject the switch to freezing conditions or condensation.

●Handling

- Avoid shock damage to the product when handling. Shock can cause deformation or break of the product.
- Do not apply excessive operating force to the switch to avoid deformation or damage.
- Apply an operating force not exceeding 30N {3,059 gf}.
Do not apply a load from an angle or from the side of the actuator.

●RoHS Compliant

The "RoHS Compliant" designation indicates that the listed models do not contain the six hazardous substances covered by the RoHS Directive.

Reference:

The following standards are used to determine compliance for the six substances.

Lead	: 1,000 ppm max.
Mercury	: 1,000 ppm max.
Cadmium	: 100 ppm max.
Hexavalent chromium:	1,000 ppm max.
PBB	: 1,000 ppm max.
PBDE	: 1,000 ppm max.

• Application examples provided in this document are for reference only. In actual applications, confirm equipment functions and safety before using the product.
• Consult your OMRON representative before using the product under conditions which are not described in the manual or applying the product to nuclear control systems, railroad systems, aviation systems, vehicles, combustion systems, medical equipment, amusement machines, safety equipment, and other systems or equipment that may have a serious influence on lives and property if used improperly. Make sure that the ratings and performance characteristics of the product provide a margin of safety for the system or equipment, and be sure to provide the system or equipment with double safety mechanisms.

Note: Do not use this document to operate the Unit.