

REVISIONS				
ZONE	REV	DESCRIPTION	DATE	APPROVED
	A	ECN 0679	30-OCT-09	
	B	ECN 0684	15-APR-10	
	C	ECN 0784	06-JUN-16	
	D	ECN 0797	17-FEB-17	

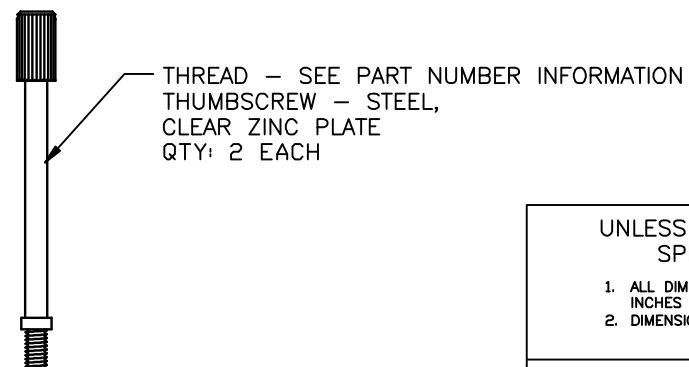
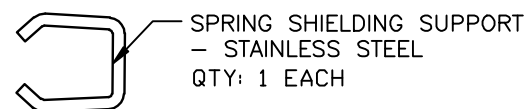
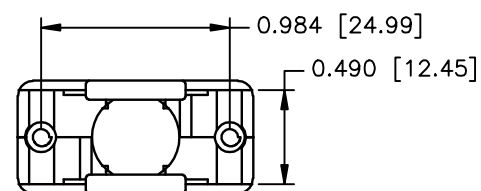
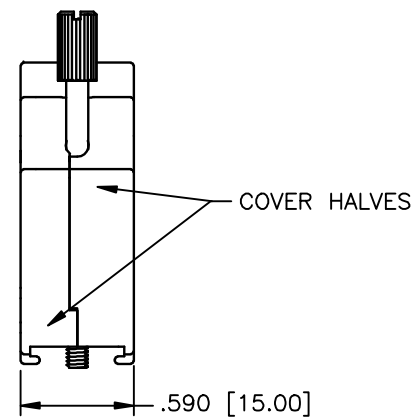
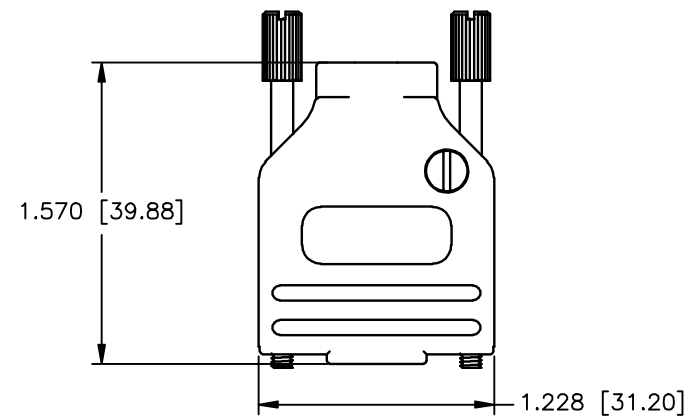

THIS IS A CONTROLLED DOCUMENT AND IS SUBJECT TO CHANGE. CONTACT NORTHERN TECHNOLOGIES ENGINEERING FOR THE LATEST REVISION.

PART NUMBER INFORMATION

PART#	LOGO STYLE	THREAD	SUPPLIED
MHDETZK9K	NO LOGO	4-40 UNC	PACKAGED
MHDETZK9KM25	NO LOGO	M2.5	PACKAGED
MHDETZK9KM26	NO LOGO	M2.6	PACKAGED
MHDETZK9KM3	NO LOGO	M3	PACKAGED

CONNECTOR COVER:

- 1.MATERIAL: ZINC DIE-CAST
- 2.FINISH: NICKEL PLATING
- 3.DIMENSIONS: INCHES [MM]
- 4.TOLERANCE: ±0.015 [0.381]

COMPRESSION INSERT TREE

- 1.MATERIAL: ABS
- 2.COLOR: BLACK
- 3.DUROMETER: 70 - TYPE D
- 4.DIMENSIONS: INCHES [MM]
- 5.TOLERANCE: ±0.015 [0.381]

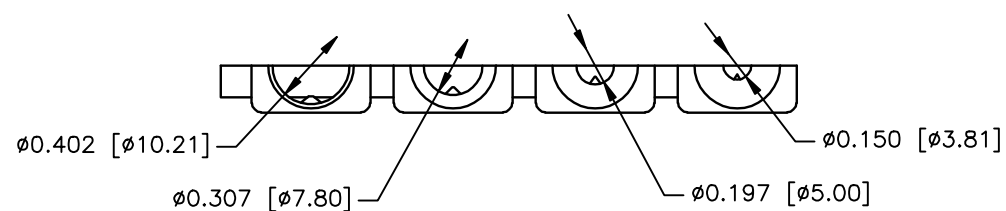
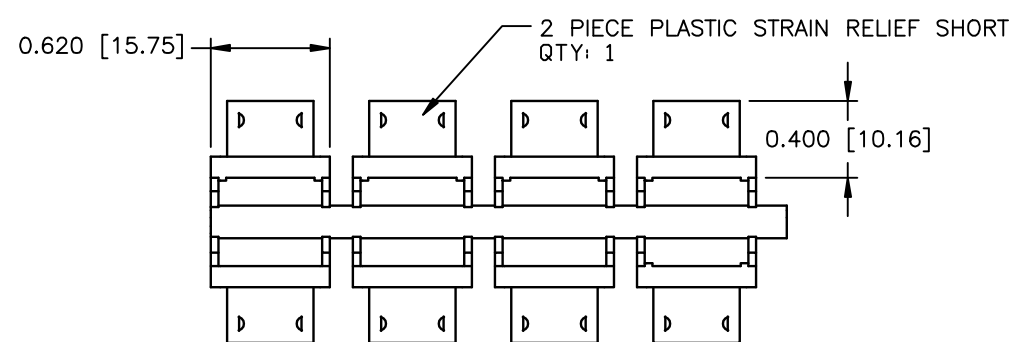

UNLESS OTHERWISE SPECIFIED 1. ALL DIMENSIONS ARE IN INCHES (MM) 2. DIMENSIONS ARE TYPICAL		<b>Northern Technologies</b> <small>THIS DRAWING IS THE PROPERTY OF NORTHERN TECHNOLOGIES AND SHOULD NOT BE REPRODUCED WITHOUT NORTHERN TECHNOLOGIES WRITTEN PERMISSION.</small>		
DRAWN JSD 14-JUL-06		PART NUMBER SEE PART NUMBER INFORMATION DESCRIPTION CMA 9 STRAIGHT EXIT METAL COVER NICKEL		
CHECKED SCN 14-JUL-06	ISSUED 14-JUL-06	SIZE B	CODE 200_199	DWG NO. 0002-200-199
		SCALE N.T.S.	REV SHEET 1 OF 1	