

# CHIP COILS

## High-frequency Winding Type LQW2BH/LQW31H Series

### LQW2BH Series

The LQW2BH series consists of air-core chip coil using a sub-miniature alumina core as a bobbin. The high Q value at high frequencies and high self-resonant frequencies make this coil perfect for use in the high frequency circuits of communications equipment.

#### ■ Features

1. LQW2BH series covers inductance range from 3.3nH to 470nH.
2. Their high self-resonant frequency characteristic yields a high Q value and highly stable inductance at high frequencies.
3. Low DC resistance design enables to handle higher allowable current.
4. The series has excellent solder heat resistance. Both flow and reflow soldering methods can be employed.

#### • LQW2BHN\_J01

Inductance tolerance  $\pm 0.5\text{nH}$  (8.2nH max.),  $\pm 5\%$  (10nH to 470nH) is realized. The sub miniature dimensions (2.0x1.5mm) allow high density mounting.

#### • LQW2BHN\_G01 (Tight inductance tolerance)

Tight inductance tolerance of  $\pm 2\%$  is available.

#### • LQW2BHN\_11

LQW2BHN\_11 using thick wire (0.12mm in diameter) has higher Q value than existing LQW2BH series.

Low DC resistance design enables to handle higher current.

LQW2BHN\_11 covers inductance range from 2.7nH to 27nH.

#### ■ Applications

- High frequency circuit in telecommunication equipment, such as DECT, PHS, PCS, PCN, GSM and CDMA.
- Impedance Matching -- Power-AMP Module (PA)
- SAW filter Resonance circuits -- VCO

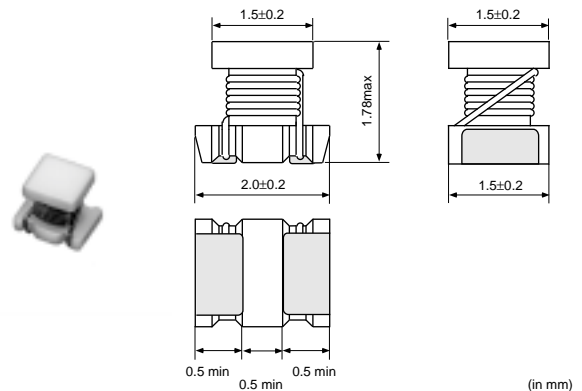

Part Number	Inductance (nH)	Rated Current (mA)	Max. of DC resistance (ohm)	Q (min.)	Self Resonance Frequency (MHz)
LQW2BHN2N7D11	2.7 $\pm 0.5\text{nH}$	1900	0.02	20 at 250MHz	6000 min.
LQW2BHN3N1D11	3.1 $\pm 0.5\text{nH}$	1800	0.02	20 at 250MHz	6000 min.
LQW2BHN3N3D01	3.3 $\pm 0.5\text{nH}$	910	0.05	10 at 250MHz	6000 min.
LQW2BHN3N3D11	3.3 $\pm 0.5\text{nH}$	1700	0.02	20 at 250MHz	6000 min.
LQW2BHN5N6D11	5.6 $\pm 0.5\text{nH}$	1500	0.02	35 at 250MHz	6000 min.
LQW2BHN6N8D01	6.8 $\pm 0.5\text{nH}$	680	0.11	20 at 250MHz	5400 min.
LQW2BHN6N8D11	6.8 $\pm 0.5\text{nH}$	1400	0.02	35 at 250MHz	5400 min.
LQW2BHN8N2D01	8.2 $\pm 0.5\text{nH}$	630	0.12	20 at 250MHz	3900 min.
LQW2BHN8N6D11	8.6 $\pm 0.5\text{nH}$	1300	0.03	35 at 250MHz	3900 min.
LQW2BHN33NG01	33 $\pm 2\%$	570	0.15	40 at 250MHz	1900 min.
LQW2BHN39NG01	39 $\pm 2\%$	730	0.09	40 at 250MHz	1700 min.
LQW2BHN47NG01	47 $\pm 2\%$	450	0.23	40 at 200MHz	1600 min.

Continued on the following page.

 Continued from the preceding page.

Part Number	Inductance (nH)	Rated Current (mA)	Max. of DC resistance (ohm)	Q (min.)	Self Resonance Frequency (MHz)
LQW2BHN56NG01	56 ±2%	430	0.26	40 at 200MHz	1500 min.
LQW2BHN68NG01	68 ±2%	460	0.23	40 at 200MHz	1200 min.
LQW2BHN82NG01	82 ±2%	320	0.42	40 at 150MHz	1100 min.
LQW2BHNR10G01	100 ±2%	270	0.55	35 at 150MHz	900 min.
LQW2BHNR12G01	120 ±2%	320	0.40	40 at 150MHz	750 min.
LQW2BHNR15G01	150 ±2%	260	0.68	30 at 150MHz	350 min.
LQW2BHNR18G01	180 ±2%	250	0.71	35 at 100MHz	700 min.
LQW2BHNR22G01	220 ±2%	240	0.7	35 at 100MHz	500 min.
LQW2BHN10NJ01	10 ±5%	1320	0.03	30 at 250MHz	3300 min.
LQW2BHN10NJ11	10 ±5%	1320	0.03	35 at 250MHz	3300 min.
LQW2BHN12NJ01	12 ±5%	680	0.11	30 at 250MHz	3200 min.
LQW2BHN15NJ01	15 ±5%	630	0.12	30 at 250MHz	2700 min.
LQW2BHN18NJ01	18 ±5%	690	0.1	30 at 250MHz	2600 min.
LQW2BHN22NJ01	22 ±5%	720	0.09	30 at 250MHz	2100 min.
LQW2BHN27NJ01	27 ±5%	540	0.17	40 at 250MHz	2300 min.
LQW2BHN33NJ01	33 ±5%	570	0.15	40 at 250MHz	1900 min.
LQW2BHN39NJ01	39 ±5%	730	0.09	40 at 250MHz	1700 min.
LQW2BHN47NJ01	47 ±5%	450	0.23	40 at 200MHz	1600 min.
LQW2BHN56NJ01	56 ±5%	430	0.26	40 at 200MHz	1500 min.
LQW2BHN68NJ01	68 ±5%	460	0.23	40 at 200MHz	1200 min.
LQW2BHN82NJ01	82 ±5%	320	0.42	40 at 150MHz	1100 min.
LQW2BHNR10J01	100 ±5%	350	0.38	40 at 150MHz	900 min.
LQW2BHNR12J01	120 ±5%	320	0.40	40 at 150MHz	750 min.
LQW2BHNR15J01	150 ±5%	390	0.47	30 at 150MHz	350 min.
LQW2BHNR18J01	180 ±5%	250	0.71	35 at 100MHz	700 min.
LQW2BHNR22J01	220 ±5%	240	0.7	35 at 100MHz	500 min.
LQW2BHN12NK11	12 ±10%	1100	0.04	40 at 250MHz	3200 min.
LQW2BHN15NK11	15 ±10%	1000	0.04	40 at 250MHz	3100 min.
LQW2BHN18NK11	18.8 ±10%	1000	0.05	40 at 250MHz	2600 min.
LQW2BHN21NK11	21 ±10%	950	0.05	40 at 250MHz	2200 min.
LQW2BHN27NK11	27 ±10%	900	0.06	40 at 250MHz	1800 min.
LQW2BHN33NK01	33 ±10%	570	0.15	40 at 250MHz	1900 min.
LQW2BHN39NK01	39 ±10%	730	0.09	40 at 250MHz	1700 min.
LQW2BHN47NK01	47 ±10%	450	0.23	40 at 200MHz	1600 min.
LQW2BHN56NK01	56 ±10%	430	0.26	40 at 200MHz	1500 min.
LQW2BHN68NK01	68 ±10%	460	0.23	40 at 200MHz	1200 min.
LQW2BHN82NK01	82 ±10%	320	0.42	40 at 150MHz	1100 min.
LQW2BHNR10K01	100 ±10%	350	0.38	40 at 150MHz	900 min.
LQW2BHNR12K01	120 ±10%	320	0.40	40 at 150MHz	750 min.
LQW2BHNR15K01	150 ±10%	390	0.47	30 at 150MHz	350 min.
LQW2BHNR18K01	180 ±10%	250	0.71	35 at 100MHz	700 min.
LQW2BHNR22K01	220 ±10%	240	0.7	35 at 100MHz	500 min.
LQW2BHNR27K01	270 ±10%	190	2.0	15 at 25.2MHz	550 min.
LQW2BHNR33K01	330 ±10%	180	2.2	15 at 25.2MHz	500 min.
LQW2BHNR39K01	390 ±10%	170	2.5	15 at 25.2MHz	400 min.
LQW2BHNR47K01	470 ±10%	160	2.8	15 at 25.2MHz	350 min.

Min. of Operating Temp. : -25°C to 85°C

■ Q-Frequency Characteristics

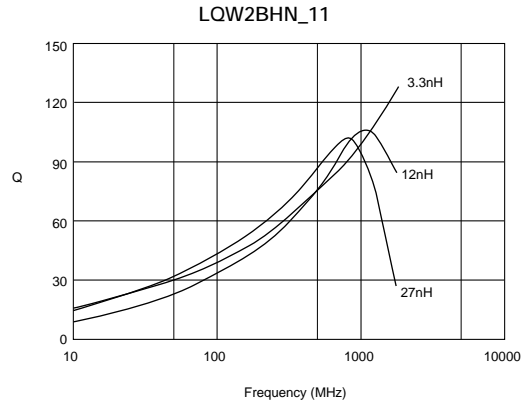
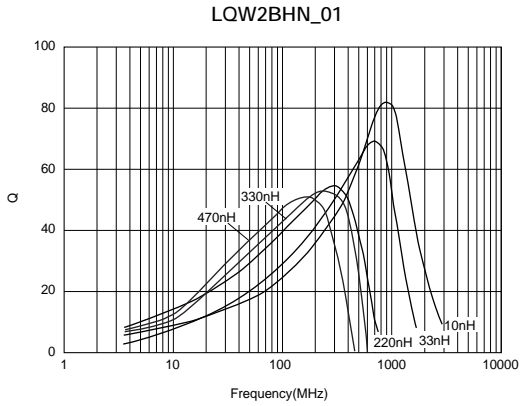

4

■ Inductance-Frequency Characteristics

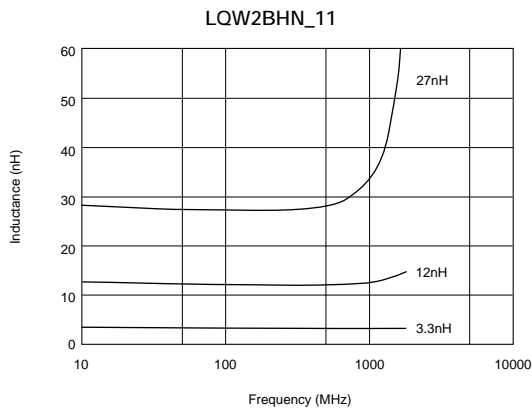

**LQW31H Series**

■ Features

The LQW31H series is alumina-core-type chip inductor for high frequency circuit. Its low dc resistance and high Q due to wound structure are suitable for hand telecommunication equipment.

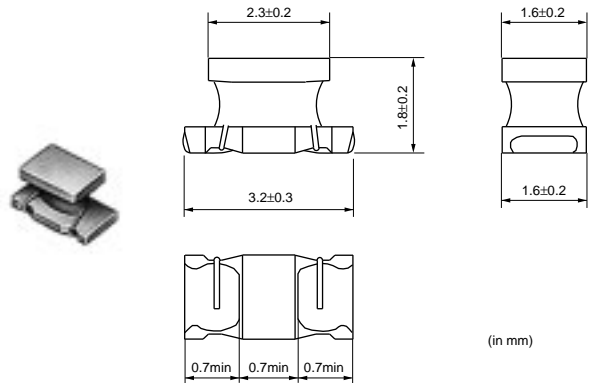

Part Number	Inductance (nH)	Rated Current (mA)	Max. of DC resistance (ohm)	Q (min.)	Self Resonance Frequency (MHz)
LQW31HN8N8J01	8.8 ±5%	750	0.0406	50 at 436MHz	1000 min.
LQW31HN15NJ01	14.7 ±5%	680	0.049	60 at 436MHz	1000 min.
LQW31HN17NJ01	17 ±5%	650	0.0518	60 at 436MHz	1000 min.
LQW31HN23NJ01	23 ±5%	590	0.0644	60 at 436MHz	1000 min.
LQW31HN27NJ01	27 ±5%	560	0.0714	60 at 436MHz	1000 min.
LQW31HN33NJ01	33 ±5%	530	0.0798	60 at 436MHz	1000 min.
LQW31HN39NJ01	39 ±5%	490	0.0938	60 at 436MHz	1000 min.
LQW31HN47NJ01	47 ±5%	380	0.154	60 at 436MHz	1000 min.
LQW31HN56NJ01	56 ±5%	330	0.196	60 at 436MHz	1000 min.
LQW31HN64NJ01	64 ±5%	290	0.252	60 at 436MHz	1000 min.
LQW31HN84NJ01	84 ±5%	240	0.392	60 at 436MHz	1000 min.
LQW31HNR10J01	100 ±5%	230	0.42	60 at 436MHz	900 min.
LQW31HN8N8K01	8.8 ±10%	750	0.0406	50 at 436MHz	1000 min.

Continued on the following page.

 Continued from the preceding page.

Part Number	Inductance (nH)	Rated Current (mA)	Max. of DC resistance (ohm)	Q (min.)	Self Resonance Frequency (MHz)
LQW31HN15NK01	14.7 ±10%	680	0.049	60 at 436MHz	1000 min.
LQW31HN17NK01	17 ±10%	650	0.0518	60 at 436MHz	1000 min.
LQW31HN23NK01	23 ±10%	590	0.0644	60 at 436MHz	1000 min.
LQW31HN27NK01	27 ±10%	560	0.0714	60 at 436MHz	1000 min.
LQW31HN33NK01	33 ±10%	530	0.0798	60 at 436MHz	1000 min.
LQW31HN39NK01	39 ±10%	490	0.0938	60 at 436MHz	1000 min.
LQW31HN47NK01	47 ±10%	380	0.154	60 at 436MHz	1000 min.
LQW31HN56NK01	56 ±10%	330	0.196	60 at 436MHz	1000 min.
LQW31HN64NK01	64 ±10%	290	0.252	60 at 436MHz	1000 min.
LQW31HN84NK01	84 ±10%	240	0.392	60 at 436MHz	1000 min.
LQW31HNR10K01	100 ±10%	230	0.42	60 at 436MHz	900 min.

Min. of Operating Temp. : -25°C to 85°C

4

### ■ Q-Frequency Characteristics

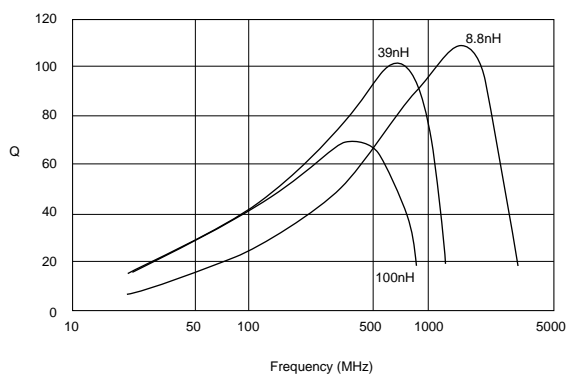

**⚠ Note:****1. Export Control**

⟨For customers outside Japan⟩

Murata products should not be used or sold for use in the development, production, stockpiling or utilization of any conventional weapons or mass-destructive weapons (nuclear weapons, chemical or biological weapons, or missiles), or any other weapons.

⟨For customers in Japan⟩

For products which are controlled items subject to the "Foreign Exchange and Foreign Trade Law" of Japan, the export license specified by the law is required for export.

**2. Please contact our sales representatives or product engineers before using our products listed in this catalog for the applications listed below which require especially high reliability for the prevention of defects which might directly cause damage to the third party's life, body or property, or when intending to use one of our products for other applications than specified in this catalog.**

- ① Aircraft equipment
- ② Aerospace equipment
- ③ Undersea equipment
- ④ Power plant equipment
- ⑤ Medical equipment
- ⑥ Transportation equipment (vehicles, trains, ships, etc.)
- ⑦ Traffic signal equipment
- ⑧ Disaster prevention / crime prevention equipment
- ⑨ Data-processing equipment
- ⑩ Application of similar complexity and/or reliability requirements to the applications listed in the above

**3. Product specifications in this catalog are as of March 2001. They are subject to change or our products in it may be discontinued without advance notice. Please check with our sales representatives or product engineers before your ordering. If there are any questions, please contact our sales representatives or product engineers.****4. The parts numbers and specifications listed in this catalog are for information only. You are requested to approve our product specification or to transact the approval sheet for product specification, before your ordering.****5. Please note that unless otherwise specified, we shall assume no responsibility whatsoever for any conflict or dispute that may occur in connection with the effect of our and/or third party's intellectual property rights and other related rights in consideration of your using our products and/or information described or contained in our catalogs. In this connection, no representation shall be made to the effect that any third parties are authorized to use the rights mentioned above under licenses without our consent.****6. None of ozone depleting substances (ODS) under the Montreal Protocol is used in manufacturing process of us.**