

HONEYWELL
PART NUMBER

64AT22 SERIES CHART 2

REV	DOCUMENT	CHANGED BY	CHECK
16	0012331	KSR 07APR05	AK

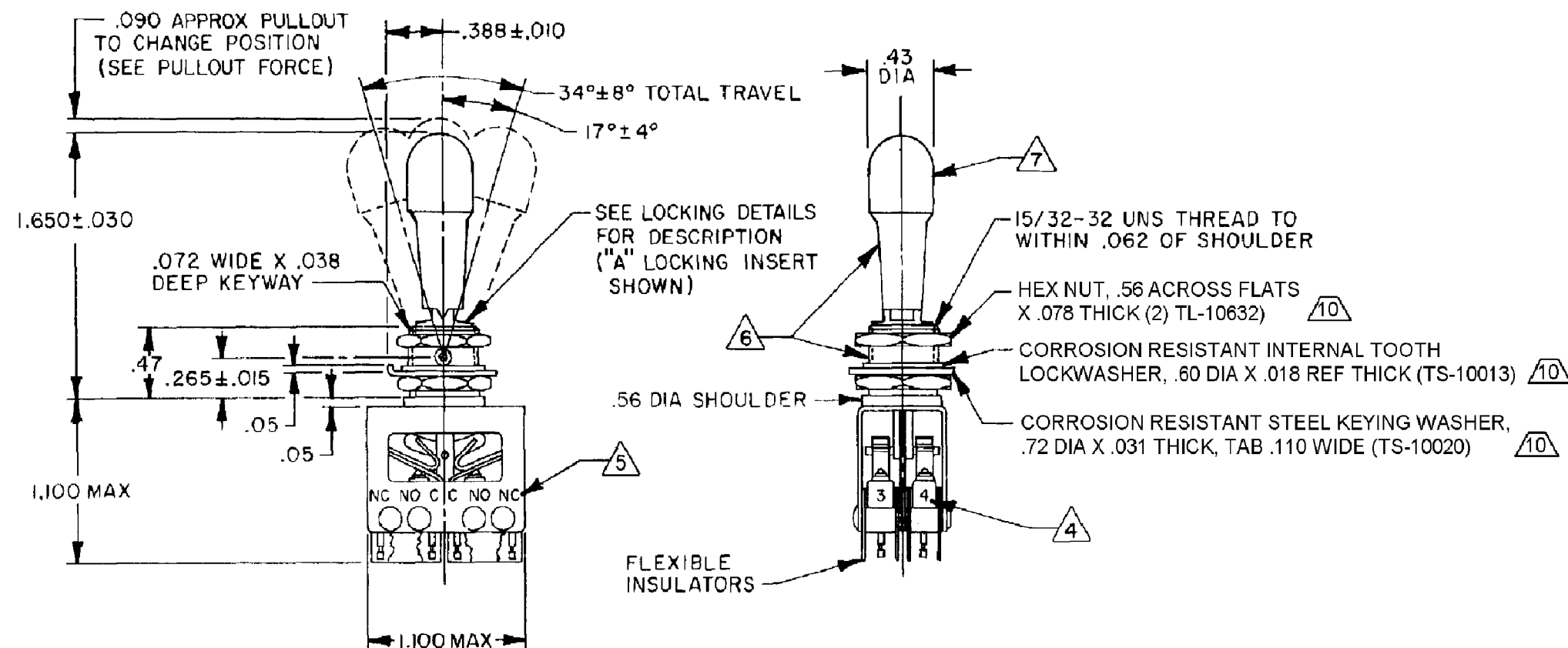

CATALOG LISTING	KEYWAY POSITION		CENTER POSITION		OPPOSITE KEYWAY POSITION		RECOMMENDED LOCKING COMBINATIONS
	C-NC	C-NO	C-NO	C-NC	C-NC	C-NO	
64AT22-1A	FAA-PMA						
64AT22-1B							
64AT22-1D							
64AT22-1E	FAA-PMA						
64AT22-1F							
64AT22-1G							
64AT22-1H							
64AT22-1J							
64AT22-1K							
64AT22-1L							
64AT22-1M							
64AT22-1N							
64AT22-1P							
64AT22-3D							
64AT22-3F							
64AT22-3G							
64AT22-5E							
64AT22-5K							
64AT22-5M							
64AT22-5N							
64AT22-7E	FAA-PMA						
64AT22-7L							
64AT22-7N							
64AT22-514B							
64AT22-514E							
64AT22-514G							
64AT22-514L							
64AT22-514N							
64AT22-514P							

* ASTERISK DENOTES MOMENTARY POSITION

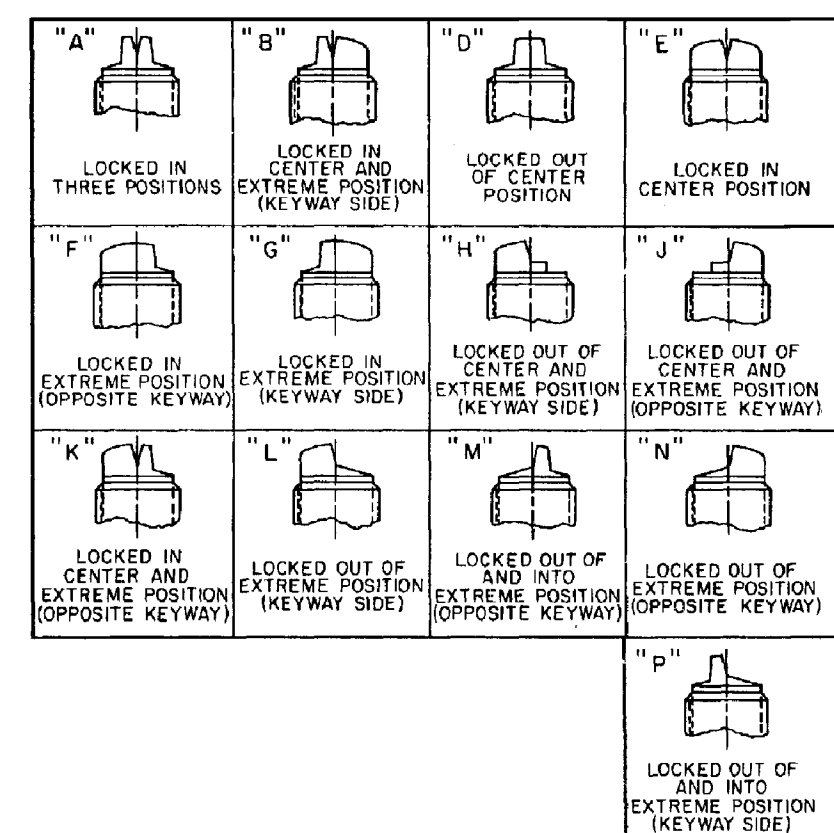

- NOTES
- UNIT INCLUDES (21SX39-H58 TYPE) BASIC SWITCH (4) (MEETS REQUIREMENTS OF MIL-8805/4)
 - SWITCHES DO NOT NECESSARILY OPERATE SIMULTANEOUSLY
 - PLATED TERMINALS WILL ACCEPT "AMP INC" .058 DIA PIN RECEPTACLES
 - SWITCH NUMBERS STAMPED ON END OF BASIC SWITCHES
 - TERMINAL DESIGNATION STAMPED ON BOTH SIDES OF UNIT
 - DULL FINISH ON LEVER AND BUSHING
 - FLAT WHITE RESILIENT SILICONE (50 DUROMETER APPROX)
 - SUFFIX LETTER MUST BE ADDED FOR DESIRED TYPE TOGGLE LOCKING (SEE CHART FOR RECOMMENDED LOCKING COMBINATIONS)
 - FOR REPLACEMENT BUTTON SEE MICRO SWITCH CAT. LIST. 15PA90-6W
 - HARDWARE FURNISHED ASSEMBLED WITH SWITCH OR IN PACKET 15PA313-AT PER MIL-PRF-8805
 - REPLACEMENT MOUNTING HARDWARE PACKET 15PA313-AT
 - SWITCH MEETS THE REQUIREMENTS OF MIL-PRF-8805/88 EXCEPT INITIAL CONTACT RESISTANCE IS 50 MILLIOHMS MAX AND FINAL CONTACT RESISTANCE AFTER MECHANICAL ENDURANCE IS 600 MILLIOHMS MAX.
 - FOR MANUFACTURING DETAIL SEE THE CORRESPONDING ASSEMBLY DRAWING FOR EACH LISTING FOR FAA-PMA.

LOAD	ELECTRICAL RATINGS		
	SEA LEVEL		50,000 FT
	28 Vdc (AMPERES)	115 Vac, 60 Hz (AMPERES)	28 Vdc (AMPERES)
RESISTIVE	7	7	4
INDUCTIVE	4	7	2.5

CHARACTERISTICS	ELECTRICAL DATA
PULLOUT FORCE - - - - 3 LB MIN - 5 LB MAX	CONTACT ARRANGEMENT S P D T (4)

DESIGN UNITS: INCH
TOLERANCES UNLESS NOTED:

NO PLACE	X	±	
ONE PLACE	.X	±	0.030
TWO PLACE	.XX	±	0.015
THREE PLACE	.XXX	±	0.005
FOUR PLACE	.XXXX	±	
ANGLES		±	

THIRD ANGLE PROJECTION

DRAWN: CSL 12MAR98
CHECK: MDM 11FEB04

THIS DRAWING COVERS A PROPRIETARY ITEM AND IS THE PROPERTY OF HONEYWELL. THIS DRAWING IS NOT TO BE COPIED OR USED WITHOUT THE PERMISSION OF HONEYWELL.

INTERPRET PER ASME Y14.5M-1994 OTHER HONEYWELL ENGINEERING STANDARDS MAY APPLY

RASTER

Honeywell

TITLE: ASSEMBLY - TOGGLE SWITCH

SIZE: C	TYPE: I	DRAWING NAME: 64AT22 SERIES CHART 2	REV: 16
SCALE: FULL	WEIGHT: .09 LB EST	SHEET 1 OF 1	