

Helping Customers Innovate, Improve & Grow

Table 1. Electrical Performance

Parameter	Symbol	Min.	Typ	Max	Units
Nominal Frequency	F _{NOM}	3.500		100.000	MHz
Mode		Fundamental, 3rd Overtone			
Operating Temperature Range	T _{OP}	0/70, -10/70, -20/70, -40/85			°C
Stability Over T _{OP} ¹	F _{STAB}	±10		±100	ppm
Frequency Tolerance ²	F _{TOL}		±10		ppm
Load Capacitance	C _L	6		32	pF
Shunt Capacitance	C _o			5	pF
Drive Level			10	100	uW
Aging / 1st year (at 25 °C)	F _{AGE}			±5	ppm
Insulation Resistance		500			MOhm
Storage Temperature	T _{STO}	-40		90	°C
Equivalent Series Resistance					
Crystal Frequency	ESR				Ohm
3.500MHz-3.579MHz				250	
3.580MHz-4.000MHz				150	
4.001MHz-5.000MHz				120	
5.001MHz-6.000MHz				100	
6.001MHz-7.000MHz				80	
7.001MHz-10.000MHz				60	
10.001MHz-14.000MHz				50	
14.001MHz-20.000MHz				40	
20.001MHz-40.000MHz, Fundamental				30	
24.001MHz-35.000MHz, 3rd Overtone				100	
35.000MHz-100.000MHz, 3rd Overtone				80	

Notes:

1. Referenced to the Frequency at 25 °C.

2. Frequency measured at 25 °C ± 3 °C.

Product is compliant to RoHS directive and fully compatible with lead free assembly.



Package Drawing

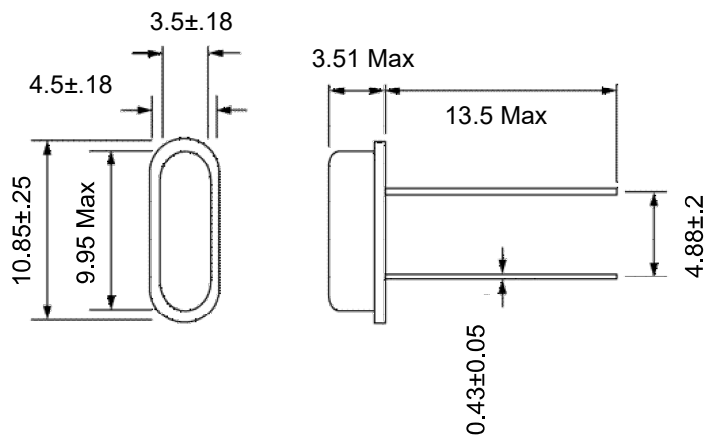

All Dimensions in mm

Ordering Information

VXA4 - XXX - XX- xxMxxxxxxx

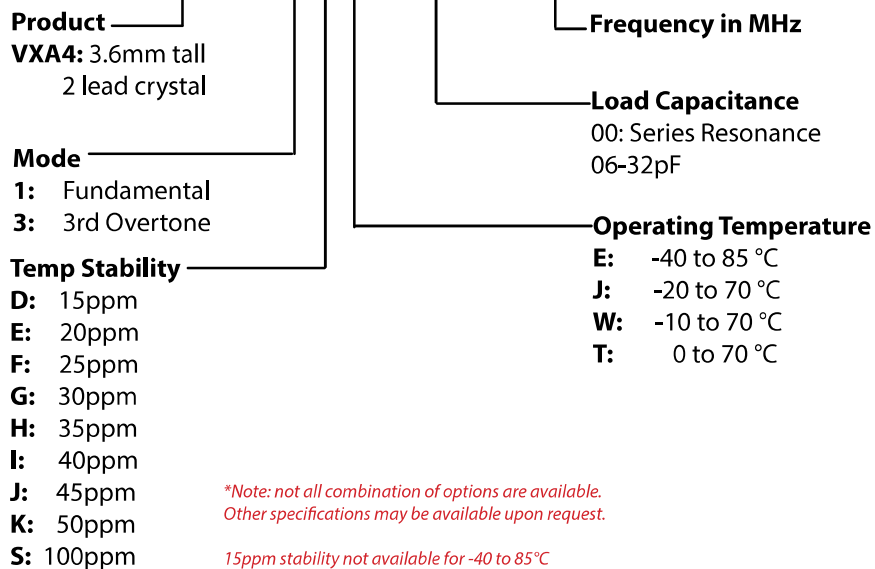

Revision History

Revision Date	Approved	Description
August 30, 2016	RC	Initial datasheet for factory approval and release to customer.
August 10, 2018	FB	Update logo and contact information
June 10, 2019	FB	Update logo and contact information

**Previous Ordering Information for Reference Only
Do Not Use to Build a New Part Number**

VXA4-1A2-10M000

Package

VXA4: HC-49/US, 3.51 mm tall

Mode

1 : Fundamental
3: 3rd Overtone

Stability

A: ±100 ppm over -20° C to 70° C
B: ±50 ppm over -20° C to 70° C
C: ±100 ppm over -40° C to 85° C
D: ±50 ppm over -40° C to 85° C
F: ±30 ppm over -20° C to 70° C

Frequency

Load Capacitance

0: Series Resonant
1: 16 pf
2: 20 pf
3: 32 pf
4: 18 pf
5: 10 pF
6: 30 pf

The ordering codes for the VXA4 were changed in 2016. If you had ordered a specific code based off this ordering method, it is still available for purchase under the old code however no new part numbers will be created using this system.

Due to the change in the 8th character from numeric to alphabetic, there is no opportunity for overlap between the two ordering methods.

Contact Information

USA:

100 Watts Street
Mt Holly Springs, PA 17065
Tel: 1.717.486.3411
Fax: 1.717.486.5920

Europe:

Landstrasse
74924 Neckarbischofsheim
Germany
Tel: +49 (0) 7268.801.0
Fax: +49 (0) 7268.801.281



Information contained in this publication regarding device applications and the like is provided only for your convenience and may be superseded by updates. It is your responsibility to ensure that your application meets with your specifications. MICROCHIP MAKES NO REPRESENTATION OR WARRANTIES OF ANY KIND WHETHER EXPRESS OR IMPLIED, WRITTEN OR ORAL, STATUTORY OR OTHERWISE, RELATED TO THE INFORMATION INCLUDING, BUT NOT LIMITED TO ITS CONDITION, QUALITY, PERFORMANCE, MERCHANTABILITY OR FITNESS FOR PURPOSE. Microchip disclaims all liability arising from this information and its use. Use of Microchip devices in life support and/or safety applications is entirely at the buyer's risk, and the buyer agrees to defend, indemnify and hold harmless Microchip from any and all damages, claims, suits, or expenses resulting from such use. No licenses are conveyed, implicitly, or otherwise, under any Microchip intellectual property rights unless otherwise stated.

Trademarks

The Microchip and Vectron names and logos are registered trademarks of Microchip Technology Incorporated in the U.S.A. and other countries.