

D

D

C

C

B

B

A

A

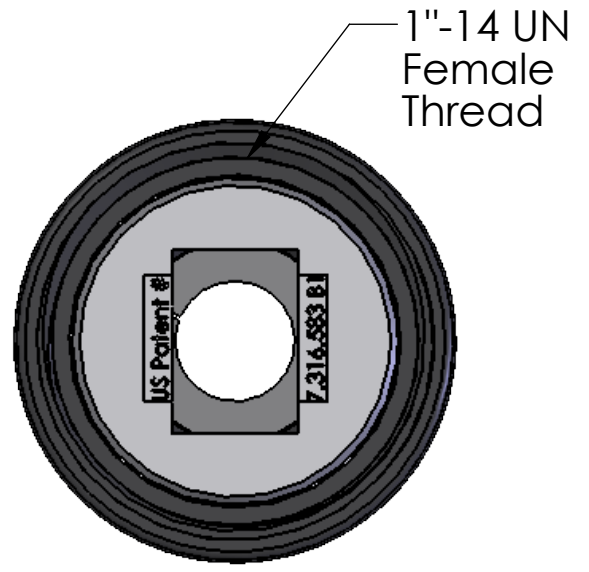

1"-14 UN
Female
Thread

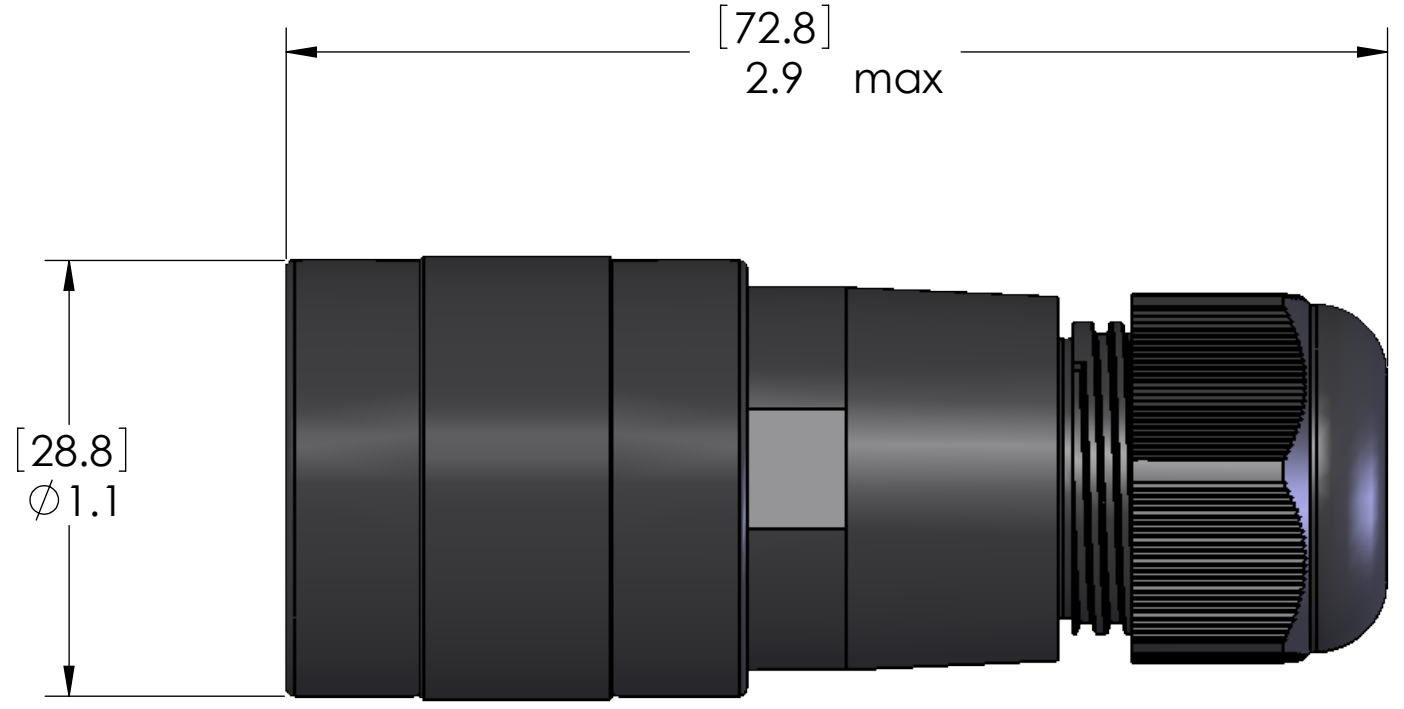

[72.8]
2.9 max

[28.8]
Ø 1.1

For assembly instructions see Instruction Sheet (Page 2)
Cable range: 5-13mm

MATERIALS:	
BODY & CAP:	BLACK POLYAMIDE
GROMMET:	TPE
COUPLING:	BLACK ANODIZED ALUMINUM
O-RING:	NBR
CERTIFICATIONS:	
SEAL:	UL TYPE 4 & 6P IP67
US:	UL LISTED
CANADA:	c-UL LISTED

PROPRIETARY AND CONFIDENTIAL
THE INFORMATION CONTAINED IN THIS DRAWING IS THE SOLE PROPERTY OF MENCOM CORPORATION. ANY REPRODUCTION IN PART OR AS A WHOLE WITHOUT THE WRITTEN PERMISSION OF MENCOM CORPORATION IS PROHIBITED.

UNLESS OTHERWISE SPECIFIED: DIMENSIONS ARE IN MM TOLERANCES: FRACTIONAL ± 1/64 ANGULAR: MACH ± 3° BEND ± 5° ONE PLACE DECIMAL ± .2 TWO PLACE DECIMAL ± .1	DRAWN BY	ADM
	DRAWN DATE	09/22/2016
	CHECKED BY	
	CHECK DATE	
MATERIAL	COMMENTS:	
FINISH		
DO NOT SCALE DRAWING		

MENCOM CORPORATION		
TITLE: FW E45V3 PLUG		
SIZE B	DWG. NO. E45V3-8MP-FW	REV A
SCALE: 2:1	WEIGHT:	SHEET 1 OF 2

Assembly Instructions

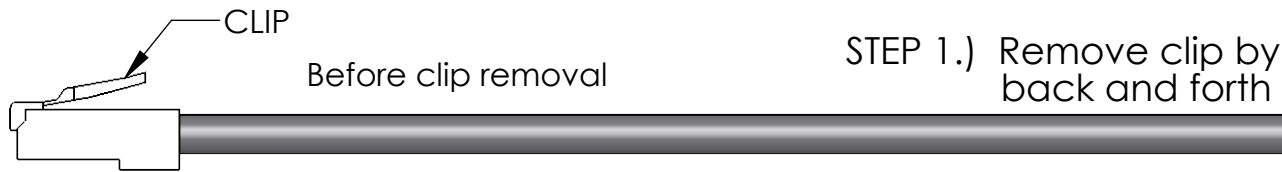

STEP 1.) Remove clip by cutting or by bending it back and forth until it breaks.

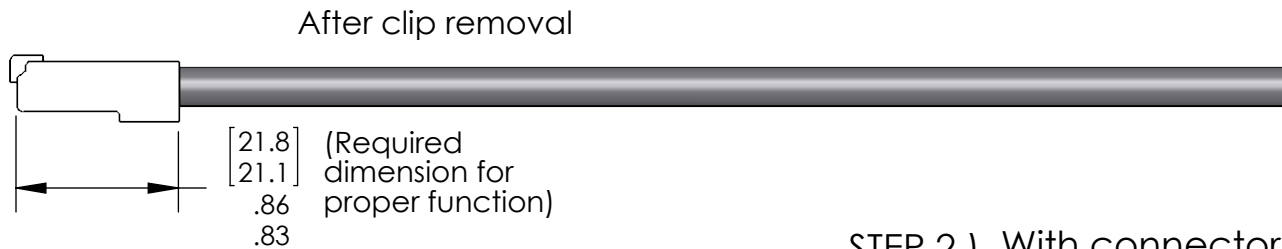

STEP 2.) With connector unassembled, push cable through dome nut, split apart the grommet and wrap it around the cable, then push the cable through the remainder of the connector.

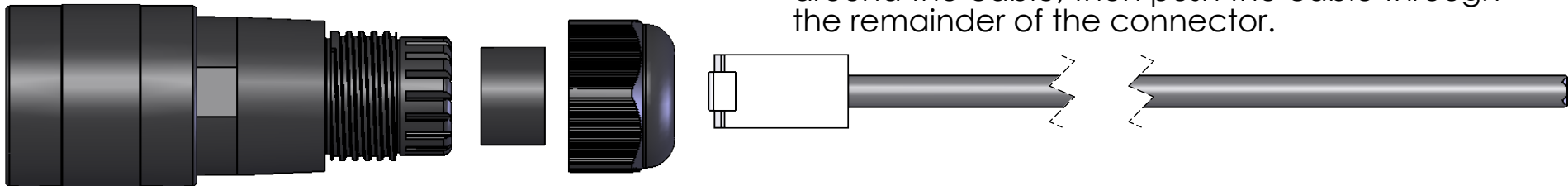

STEP 3.) Push grommet back into the "fingers" of the shell. Rotate cable 90 degrees and pull it back into connector until it stops. With slight tension on cable, tighten dome nut (3.75Nm recommended).

